

NORMAL

**MWO 55-1500-219-30-8
CHANGE NO. 10**

DEPARTMENT OF THE ARMY MODIFICATION WORK ORDER

**INSTALLATION OF FIVE (5) - VOLT
INSTRUMENT LIGHTING SYSTEM
IN UH-1H HELICOPTERS (MEDEVAC)**

Headquarters, Department of the Army, Washington, D.C.

29 July 1994

MWO 55-1500-219-30-8, 25 July 1980, is changed as follows:

Page 1. Note at top of page is changed to read, "MWO effective date 1 October 1979 and completion date 1 March 1996."

By Order of the Secretary of the Army:

Official:

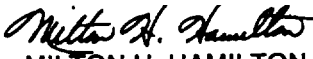
MILTON H. HAMILTON
*Administrative Assistant to the
Secretary of the Army*
07119

GORDON R. SULLIVAN
*General, United States Army
Chief of Staff*

DISTRIBUTION:

To be distributed in accordance with DA Form 12-31-E, block no. 1273, requirements for MWO 55-1500-219-30-8.

DISTRIBUTION STATEMENT A: Approved for public release; distribution is unlimited.

N O R M A L

MWO 55-1500-219-30-8

CHANGE NO. 9

DEPARTMENT OF THE ARMY MODIFICATION WORK ORDER

INSTALLATION OF FIVE (5) — VOLT
INSTRUMENT LIGHTING SYSTEM
IN UH-1H HELICOPTERS (MEDEVAC)

Headquarters, Department of the Army, Washington, D.C.
29 May 1992

MWO 55-1500-219-30-8, 25 July 1980, is changed as follows:

Page 1. Paragraph 3, List of Serial Numbers will be added as follows:

69-21570 70-16137
By Order of the Secretary of the Army:

GORDON R. SULLIVAN
General, United States Army
Chief of Staff

Official:

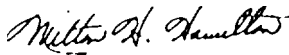
MILTON H. HAMILTON
Administrative Assistant to the
Secretary of the Army
02182

DISITRIBUTION: To the distributed in accordance with DA Form 12-31-E block No. 1273, MWO requirements for MWO 55-1500-219-30-8.

DISTRIBUTION STATEMENT A: Approved for public release; distribution is unlimited.

1/(2 blank)

*U.S. GOVERNMENT PRINTING OFFICE: 1992 - 654-028/60341

N O R M A L

MWO 55-1500-219-30-8

CHANGE NO. 8

DEPARTMENT OF THE ARMY MODIFICATION WORK
O R D E R

INSTALLATION OF FIVE (5)-VOLT INSTRUMENT
LIGHTING SYSTEM
IN UH-1H HELICOPTERS (MEDEVAC)

Headquarters, Department of the Army, Washington, D.C.
31 January 1992

MWO 55-1500-219-30-8, 25 July 1980, is changed as follows:

Page 1. Note at top of page is changed to read, "MWO effective date 1 October 1979 and completion date 31 December 1992".

Page 3. Paragraph 6a is superseded as follows:

a. Time Compliance Schedule. MWO effective date 10 October 1979 and completion date 31 December 1992.

By Order of the Secretary of the Army:

Official:

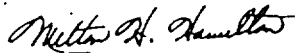

MILTON H. HAMILTON
*Administrative Assistant to the
Secretary of the Army*
00633

GORDON R. SULLIVAN
*General, United States Army
Chief of Staff*

DISTRIBUTION: To be distributed in accordance with DA Form 12-31-E block No. 1273, MWO requirements for MWO 55-1500-219-30-8.

NORMAL

MWO 55-1500-219-30-8

CHANGE NO. 7

DEPARTMENT OF THE ARMY MODIFICATION WORK ORDER

INSTALLATION OF FIVE (5)-VOLT INSTRUMENT
LIGHTING SYSTEM
IN UH-1H HELICOPTERS (MEDEVAC)

Headquarters, Department of the Army, Washington, D. C.

18 April 1988

MWO 55-1500-219-30-8, 25 July 1980, is changed as follows:

Page 1, paragraph 3. Add serial number 66-1062 to list of aircraft to be modified in proper numerical order.

Page 1, paragraph 3. Delete serial number 68-16338.

By Order of the Secretary of the Army:

Official:

CARL E. VUONO,
General, United States Army
Chief of Staff

R.L.DILWORTH
Brigadier General, United States Army
The Adjutant General

DISTRIBUTION:

To be distributed in accordance with DA Form 12-31, MWO requirements for UH-1H Helicopter, Utility

URGENT

MWO 55-1500-219-30-8
CHANGE NO. 6

DEPARTMENT OF THE ARMY MODIFICATION WORK ORDER

INSTALLATION OF FIVE (5)-VOLT INSTRUMENT
LIGHTING SYSTEM
IN UH-1H HELICOPTERS (MEDEVAC)

Headquarters, Department of the Army, Washington, D. C.

15 November 1987

MWO 55-1500-219-30-8, 25 July 1980, is changed as follows:

Page 1. Note at top of page is changed to read, "MWO effective date 1 October 1979 and completion date 1 October 1988".

Page 3. Paragraph 6a is superseded as follows:

a. Time Compliance Schedule. MWO effective date 1 October 1979 and completion date 1 October 1988.

By Order of the Secretary of the Army:

CARL E. VUONO
General, United States Army
Chief of Staff

Official:

R. L. DILWORTH
Brigadier General, United States Army
The Adjutant General

DISTRIBUTION:

To be distributed in accordance with DA Form 12-31, MWO requirements for UH-1H aircraft.

NORMAL

MWO 55-1500-219-30-8

CHANGE NO. 5

DEPARTMENT OF THE ARMY MODIFICATION WORK ORDER

INSTALLATION OF FIVE (5)-VOLT INSTRUMENT LIGHTING SYSTEM IN UH-1H HELICOPTERS (MEDEVAC)

Headquarters, Department of the Army, Washington, D. C.

15 JULY 1985

MWO 55-1500-219-30-8, 25 July 1980, is changed as follows:

Page 1. Note at top of page is changed to read, "MWO effective date 1 October 1979 and completion date 30 September 1987. "

Page 1, paragraph 3. Add serial number 69-15946 to list of aircraft to be modified in proper numerical order.

Page 1, paragraph 3. Delete serial number 69-15308.

Page 3. Paragraph 6a is superseded as follows:

a. Time Compliance Schedule. MWO effective date 1 October 1979 and completion date 30 September 1987.

By Order of the Secretary of the Army:

Official:

DONALD J. DELANDRO
Brigadier General, United States Army
The Adjutant General

JOHN A. WICKHAM, JR.
General, United States Army
Chief of Staff

DISTRIBUTION:

To be distributed in accordance with DA Form 12-31, MWO requirements for UH-1D/H/V/EH-1H aircraft.

N O R M A L

MWO 55-1500-219-30-8
Change No. 4

DEPARTMENT OF THE ARMY MODIFICATION WORK ORDER

INSTALLATION OF FIVE (5)-VOLT INSTRUMENT
LIGHTING SYSTEM
IN UH-1H HELICOPTERS (MEDEVAC)

Headquarters, Department of the Army, Washington, D.C.

1 February 1984

MWO 55-1500-219-30-8, 25 July 1980, is changed as follows:

Title is changed as shown above.

Page 1, paragraph 3. Add serial numbers 68-16229, 69-15308, 71-20332, 72-21589 and 73-21691 to list of aircraft to be modified in proper numerical order.

By Order of the Secretary of the Army:

JOHN A. WICKHAM, JR.
General, *United States Army*
Chief of Staff

Official:

ROBERT M. JOYCE
Major General, *United States Army*
The Adjutant General

DISTRIBUTION:

To be distributed in accordance with DA Form 12-31, MWO requirements for UH-1D/H, EH-1H aircraft.

N O R M A L

MWO 55-1500-219-30-8
Change No. 3

DEPARTMENT OF THE ARMY MODIFICATION WORK ORDER

INSTALLATION OF FIVE (5)-VOLT INSTRUMENT
LIGHTING SYSTEM
IN UH-1H HELICOPTERS (MEDEVAC)

Headquarters, Department of the Army, Washington, D. C.

10 October 1983

MWO 55-1500-219-30-8, 25 July 1980, is changed as follows:

Page 1. Note at top of page is changed to read, "MWO effective date 1 October 1979 and completion date 30 September 1984."

Page 3. Paragraph 6a is superseded as follows:

a. Time Compliance Schedule. MWO effective date 1 October 1979 and completion date 30 September 1984.

By Order of the Secretary of the Army:

JOHN A. WICKHAM, JR.
General, United States Army
Chief of Staff

Official:

ROBERT M. JOYCE
Major General, United States Army
The Adjutant General

DISTRIBUTION:

To be distributed in accordance with DA Form 12-31, MWO requirements for UH-1D/H, EH-1H aircraft.

DEPARTMENT OF THE ARMY MODIFICATION WORK ORDER

INSTALLATION OF FIVE (5)-VOLT INSTRUMENT
LIGHTING SYSTEM
IN UH-1H HELICOPTERS (MEDEVAC)

Headquarters, Department of the Army, Washington, D. C.

19 May 1982

MWO 55-1500-219-30-8, 25 July 1980, is changed as follows:

Page 1, para. 3. Add Serial Number 66-0853 to the list of aircraft to be modified in proper numerical order.

Page 1, para. 3. Delete Serial Numbers 66-1127, 69-15474, 69-15481, and 69-15915.

By Order of the Secretary of the Army:

E. C. MEYER
General, United States Army
Chief of Staff

Official:

ROBERT M. JOYCE
Brigadier General, United States Army
The Adjutant General

Distribution:

To be distributed in accordance with DA Form 12-31, MWO requirements for UH-1D/H and EH-1H aircraft.

DEPARTMENT OF THE ARMY MODIFICATION WORK ORDER

INSTALLATION OF FIVE (5)-VOLT INSTRUMENT
LIGHTING SYSTEM
IN UH-1H HELICOPTERS (MEDEVAC)

Headquarters, Department of the Army, Washington, D. C.

6 April 1981

MWO 55-1500-219-30-8, 25 July 1980, is changed as follows:

Title is changed as shown above.

Page 1, paragraph 3 is superseded as follows:

3. End Item or System to be Modified. The following aircraft will be modified:

Nomenclature	National Stock Number	Model	Serial Number
Helicopter	1520-00-087-7637	UH-1H	66-0873,66-0890, 66-0941,66-0954, 66-1018,66-1046, 66-1050,66-1052, 66-1068,66-1086,66-1087 66-1104,66-1105, 66-1127,66-1193, 66-16005, 66-16013, 66-16034, 66-16108, 66-16119, 66-16143, 66-16155, 66-16187, 66-16201, 66-16228, 66-16239, 66-16243, 66-16252, 66-16272, 66-16291, 66-16296, 66-16316, 66-16328, 66-16355, 66-16366, 66-16372, 66-16387, 66-16395, 66-16415, 66-16419, 66-16431, 66-16446, 66-16456, 66-16475, 66-16478, 66-16484, 66-16506, 66-16508, 66-16513, 66-16525, 66-16538, 66-16609, 66-16620, 66-16633, 66-16639, 66-16678, 66-16680, 66-16717, 66-16729, 66-16757, 66-16821,

Nomenclature	National Stock Number	Model	Serial Number
			66-16827, 66-16836,
			66-16868, 66-16877,
			66-16879, 66-16894,
			66-16896, 66-16965, 66-16969
			66-16971, 66-16972,
			66-16998, 66-17004,
			66-17013, 66-17024,
			66-17030, 66-17054,
			66-17081, 66-17089,
			66-17091, 66-17099,
			66-17100, 66-17111,
			66-17144, 67-17146,
			67-17189, 67-17198,
			67-17200, 67-17216,
			67-17220, 67-17236,
			67-17258, 67-17268,
			67-17289, 67-17292,
			67-17334, 67-17406,
			67-17414, 67-17416,
			67-17455, 67-17523,
			67-17526, 67-17527,
			67-17534, 67-17535,
			67-17540, 67-17547,
			67-17599, 67-17637,
			67-17645, 67-17661,
			67-17725, 67-17781,
			67-17808, 67-17810,
			67-17813, 67-17814,
			67-19494, 67-19521,
			67-19534, 68-15214,
			68-15227, 68-15431,
			68-15444, 68-15461,
			68-15492, 68-15526,
			68-15532, 68-15543,
			68-15550, 68-15592,
			68-15593, 68-15622, 68-15678
			68-15688, 68-15743,
			68-15749, 68-15754,
			68-15773, 68-16077,
			68-16084, 68-16138,
			68-16165, 68-16174,
			68-16187, 68-16235, 68-16252
			68-16261, 68-16263,
			68-16321, 68-16349,
			68-16355, 68-16415,
			68-16417, 68-16421,
			68-16446, 68-16507,
			68-16519, 68-16553,
			68-16563, 68-16596,
			69-15002, 69-15016,
			69-15053, 69-15062,
			69-15081, 69-15102,
			69-15144, 69-15171,
			69-15180, 69-15208,
			69-15219, 69-15229,
			69-15247, 69-15249,

Nomenclature	National Stock Number	Model	Serial Number
			69-15253, 69-15267,
			69-15268, 69-15271,
			69-15282, 69-15294,
			69-15298, 69-15322,
			69-15323, 69-15326,
			69-15330, 69-15331,
			69-15332, 69-15339,
			69-15341, 69-15370,
			69-15408, 69-15425,
			69-15469, 69-15474,
			69-15481, 69-15518,
			69-15545, 69-15636,
			69-15683, 69-15719,
			69-15730, 69-15758,
			69-15790, 69-15814,
			69-15818, 69-15844,
			69-15845, 69-15848,
			69-15854, 69-15913,
			69-15915, 69-15924,
			69-15926, 69-15928,
			69-15929, 69-15930,
			69-15931, 69-16652,
			69-16719, 69-16727,
			70-15711, 70-15754,
			70-15860, 70-16209,
			70-16224, 70-16225,
			70-16238, 70-16248,
			70-16249, 70-16259,
			70-16262, 70-16266,
			70-16280, 70-16309,
			70-16360, 70-16361,
			70-16364, 70-16368,
			70-16370, 70-16371,
			70-16372, 70-16373,
			70-16378, 70-16379,
			70-16380, 70-16381,
			70-16382, 70-16383,
			70-16385, 70-16386,
			70-16387, 70-16389,
			70-16390, 70-16391,
			70-16392, 70-16393,
			70-16394, 70-16437, 70-16422
			70-16439, 70-16440,
			70-16464, 70-16465,
			70-16468, 71-20009,
			71-20018, 71-20023,
			71-20024, 71-20026,
			71-20050, 71-20063,
			71-20088, 71-20105,
			71-20156, 71-20159,
			71-20164, 71-20177,
			71-20206, 71-20214,
			71-20223, 71-20228,
			71-20247, 71-20271,
			71-20280, 71-20284,
			71-20285, 71-20294,

Nomenclature	National Stock Number	Model	Serial Number
			71-20300, 71-20301,
			71-20302, 71-20303,
			71-20305, 71-20306,
			71-20307, 71-20315,
			72-21508, 72-21517,
			72-21533, 72-21547,
			72-21559, 72-21629,
			72-21638, 73-21664,
			73-21666, 73-21689,
			73-21717, 73-21718,
			73-21719, 73-21720,
			73-21732, 73-21745,
			73-21748, 73-21756,
			73-21763, 73-21765,
			73-21767, 73-21778,
			73-21791, 73-21807,
			73-21820, 73-21832,
			73-21859, 73-22066,
			73-22067, 73-22080,
			73-22091, 73-22097,
			74-22298, 74-22299,
			74-22311, 74-22312,
			74-22341, 74-22354,
			74-22366, 74-22372,
			74-22373, 74-22376,
			74-22377, 74-22398,
			74-22407, 74-22421,
			74-22425, 74-22428,
			74-22430, 74-22431,
			74-22432, 74-22433,
			74-22442, 74-22447,
			74-22463, 74-22468,
			74-22472, 74-22473,
			74-22482, 74-22498,
			74-22542

By Order of the Secretary of the Army:

E. C. MEYER
General, United States Army
Chief of Staff

Official:

J. C. PENNINGTON
Major General, United States Army
The Adjutant General

DISTRIBUTION:

To be distributed in accordance with DA Form 12-31, MWO requirements for UH-1D/H and EH-1H aircraft.

N O R M A L

MWO effective date 1 October 1979 and completion date 31 March 1983

MWO 55-1500-219-30-8

DEPARTMENT OF THE ARMY MODIFICATION WORK ORDER

INSTALLATION OF FIVE (5)-VOLT INSTRUMENT LIGHTING SYSTEM IN UH-1H HELICOPTERS (MEDIVAC)

Headquarters, Department of the Army, Washington, D. C.

25 July 1980

REPORTING ERRORS AND RECOMMENDING IMPROVEMENTS

You can help improve this manual. If you find any mistakes or if you know of a way to improve the procedures, please let us know. Mail your letter, DA Form 2028 (Recommended Changes to Publications and Blank Forms) or DA Form 2028-2 located in the back of this manual direct to: Commander, U. S. Army Troop Support and Aviation Materiel Readiness Command, ATTN: DRSTS-MTPS, 4300 Goodfellow Blvd., St. Louis, MO 63120. A reply will be furnished to you.

1. Purpose of Modification. The purpose of this modification is to install the 5-Volt Instrument Lighting System and is required to achieve compatibility with other equipment with which the affected equipment will be operated.

2. Priority Classification. This modification is classified as NORMAL.

a. Equipment in Use (including equipment in supply or maintenance activities below depot level and equipment in administrative storage). Equipment in use will be modified as soon as practicable but no later than the scheduled completion date. Equipment not modified after expiration of MWO completion date will be reported as NORM/NOT READY in accordance with applicable Army regulations.

b. Equipment in Wholesale Depot Supply or Maintenance Activities. All MWOs, to include MWOs which have been incorporated into DMWR, will be accomplished on serviceable materiel prior to issue and/or subsequent to scheduled completion date. Operational Project Stock stored at the depots will be modified concurrently with depot stock. The MWO will be applied to unserviceable materiel during scheduled depot maintenance, as applicable.

c. Prepositioned Stock. Equipment which is prepositioned will be modified during cyclic maintenance and will be consistent with TM 38-450.

3. End Item or System to be Modified. The following aircraft will be modified:

Nomenclature	National Stock Number	Model	Serial Number
Helicopter	1520-00-859-2670	UH-1D	60-6028 through 60-6034
		or	62-2106 through 62-2113
	1520-00-087-7637	UH-1H	62-12351 through 62-12372
			63-8739 through 63-8859

Nomenclature	National Stock Number	Model	Serial Number
			63-12956 through 63-13002
			64-13492 through 64-13901
			65-9565 through 65-10135
			65-12773 through 65-12776
			65-12847 through 65-12852
			65-12857 through 65-12895,
			66-0746 through 66-1210
			66-8574 through 66-8577
			66-16000 through 66-17144
			67-17145 through 67-17859
			67-18411 through 67-18413
			67-18558 through 67-18577
			67-19475 through 67-19537
			68-15214 through 68-15794
			68-16050 through 68-16628
			69-15000 through 69-15577
			69-15579 through 69-15705
			69-15707 through 69-15712
			69-15714 through 69-15959
			69-16609
			69-16650 through 69-16679
			69-16692 through 69-16712
			69-16714 through 69-16732
			70-15700 through 70-15874
			70-15913 through 70-15932
			70-16200 through 70-16496
			70-16515 through 70-16518
			71-20000 through 71-20333
			72-21465 through 72-21648
			73-21661 through 73-21793
			73-21801 through 73-21810
			73-21818 through 73-21840
			73-21850 through 73-21860
			73-22066
			73-22067
			73-22072 through 73-22075
			73-22078 through 73-22082
			73-22090 through 73-22094
			73-22097 through 73-22102
			73-22122 through 73-22135
			74-22295 through 74-22483
			74-22489 through 74-22516
			74-22521 through 74-22524
			74-22526 through 74-22529
			74-22533 through 74-22544
			76-22670 through 76-22672

NOTE

Prototype kit was installed on UH-1H S/N 69-15603. Verification kit was installed on UH-1H S/N 69-15341.

4. **Modules (Components, Assemblies, Subassemblies, Boards and Cards) to be Modified.** Not applicable.

5. **Part(s) to be Modified.** Not applicable.

6. APPLICATION

a. Time Compliance Date. MWO effective date 1 October 1979 and completion date 31 March 1983.

b. Level of Maintenance. Aviation Intermediate Maintenance (AVIM).

c. Applied by:

(1) Aircraft Structural Repairer, MOS 68G.

(2) Aircraft Electrician MOS 68F.

(3) Utility Helicopter Repairer MOS 67N.

d. Time Required.

(1) For completion of MWO application to one end item.

(a) Total of 16 workhours.

(b) Total of 10 hours downtime for one end item.

(2) For completion of one assembly or component. Not applicable.

(3) For completion of one part. Not applicable.

e. MWO's to be Applied Prior to or Concurrently with the MWO. MWO 55-1500-219-30-4, Installation of Provisions for AIMS Altimeter UH-1C/M and UH-1D/H Helicopters, and MWO 55-1520-210-30-48, Installation of Altimeter Set, Electronic AN/APN-209 In UH-1H Helicopters Redesignated to UH-1V (MEDIVAC).

7. Technical Publications Affected/Changed as a Result of this MWO.

TM 55-1520-210-10

TM 11-1520-210-20

TM 55-1520-210-23

TM 11-1520-211-20

TM 55-1520-210-23P

8. Supply Kits, Parts and Disposition.

a. Kit Required to Accomplish MWO.

NSN	Nomenclature	Part Number	Quantity
1560-01-064-4578	Kit, Modification consisting of the following parts:	1560-UH1-864	1
NOTE 1	Bus bar	1560-UH1-913	1
6150-00-263-0654	Bus bar	MS25226-2-3	1
6150-00-557-7660	Bus bar	MS25226-2-4	1
5925-00-776-5062	Circuit breaker	MS22073-2-1	2
NOTE 2	Clamp	MS21919DG-5	1
NOTE 3	Clamp	MS21919DG-3	1
NOTE 4	Contact	MS24254-20P	4
5999-00-812-2082	Contact	MS24255-20S	6
NOTE 5	Decal TB-100	1560-UH1-869-3	1
NOTE 5	Decal	1560-UH1-869-1	1
NOTE 5	Decal	1560-UH1-869-2	1
NOTE 5	Decal	1560-UH1-869-4	1

NSN	Nomenclature	Part Number	Quantity
5310-00-807-1472	Nut, Self-locking	MS21042-LO6	10
5310-00-208-9255	Nut, Self-locking	MS21044-C3	10
NOTE 6	Nut, Self-locking	MS21044-LO4	2
5940-00-204-8966	Terminal Lug	MS25036-102M	13
NOTE 13	Power Supply, 5-Volt	1560-UH1-872	2
NOTE 5	Placard	1560-UH1-873-1	1
NOTE 5	Placard	1560-UH1-873-2	1
NOTE 5	Plate, Mounting	1560-UH1-838	2
5305-00-054-5649	Screw	MS51957-15	2
5305-00-543-2753	Screw	MS35266-61	8
5306-00-182-1946	Bolt	AN3CH20A	4
5306-00-180-2769	Bolt	AN3CH3A	8
5306-00-059-3659	Screw	MS51958-63	1
NOTE 5	Standoff	1560-UH1-830	8
NOTE 7	Terminal Board	MS27212-1-10	1
NOTE 8	Terminal Board Cover	MS18029-11S-10	1
5940-00-557-1629	Terminal Lug	MS25036-149	2
5940-00-143-4771	Terminal Lug	MS25036-103	5
5310-00-619-1148	Washer	MS15795-808	20
5310-00-638-9857	Washer	AN960C6L	20
5310-00-595-6211	Washer	MS15795-8-3	2
NOTE 9	Washer	AN935-6	10
5310-00-933-8118	Washer	MS35338-135	2
NOTE 10	Wire harness	1560-UH1-865	1
NOTE 11	Nylon cable tie, 4"	MS17821-4	25
NOTE 12	Nylon cable tie, 7"	MS17821-1	25

NOTE 1: For spare part support, use NSN 6150-00-225-0267.

NOTE 2: For spare part support, use NSN 5340-00-105-8328.

NOTE 3: For spare part support, use NSN 5340-00-052-9552.

NOTE 4: For spare part support, use NSN 5999-00-901-3239.

NOTE 5: Non-maintenance significant.

NOTE 6: For spare part support, use NSN 5310-00-088-0551.

NOTE 7: For spare part support, fab from NSN 5940-00-950-1610.

NOTE 8: For spare part support, fab from NSN 5940-00-082-4642.

NOTE 9: For spare part support, use NSN 5310-00-045-4007.

NOTE 10: For spare part support, assemble from NSN 5935-00-761-3885, 5975-00-727-5153, 6145-00-578-7519.

NOTE 11: For spare part support, use NSN 5975-00-727-5153.

NOTE 12: For spare part support, use NSN 5975-00-074-2072.

NOTE 13: CERCOM supported item.

b. The Weight and Cube Data for the Packaged Kit is Listed Below:

NSN	Weight	Dimensions	Cube
	5 lbs.	12" x 12" x 6	0.5 cu. ft.

c. Distribution and Issue Instructions - US Forces. Kits to accomplish this modification will not be requisitioned by user/field activities. Requisitioning of kits and application/compliance with this MWO will be accomplished only by depot/overhaul facilities or Hq TSARCOM sponsored project sites. User activities will accomplish this MWO when authorized by a negotiated Memorandum of Understanding (MOU) with Hq TSARCOM (AR 750-10).

d. Bulk and Consumable Materials. The following materials are not furnished with the kit and will be requisitioned to comply with this publication.

NSN	Nomenclature	Quantities	Part No.	Source of Supply Code
5350-00-224-7205	Paper, Abrasive	A/R	P-P-101	S9G
3439-00-224-3567	Solder, Tin Alloy	A/R	QQS571SN60	S9G
5350-00-221-0872	Crocus Cloth, Abrasive	A/R	P-C-458C	
4020-00-202-1924	Twine, Fibrous	A/R	MIL-T-713	S9I
8010-00-297-0593	Primer, Coating	A/R	TTP1757	GO
5970-00-812-2969	Insulation Sleeving	A/R	RNF-100, Type 1, 1/8 in.	S9G
8030-00-811-3723	Corrosion Resistant Coating	A/R	MIL-C-5541	GO

e. Parts Disposition. Not applicable.

f. CERCOC supported items. Not applicable.

9. Special Tools: Jigs Test, Measurement, and Diagnostic Equipment (TMDE) and Fixtures Required. Not applicable.

10. Modification Procedure.

a. Prepare the aircraft for safe ground maintenance and proceed with the following instructions for modification:

NOTE

Items removed to gain access to work area shall be tagged for identification and protected from damage until reinstalled. Retain all hardware of removed parts for reinstallation unless otherwise specified.

NOTE

Refer to TM 55-1520-210-23 for detailed parts or equipment removal and installation instructions. Refer to TM 55-1520-210-23P for detailed parts location.

NOTE

Refer to TM 55-1500-323-25 for electrical wiring installation, and electrical bonding practices.

(1) Disconnect and remove battery. Remove vertical plate located immediately aft of the battery.

(2) At nose compartment, remove the following:

(a) Receiver Transmitter RT-742/ARC-51.

(b) Receiver Transmitter RT-348/ARC-54.

(c) Receiver R-836/ARN (if installed).

(d) Receiver R-1388/ARN-82 (if installed).

(e) Receiver R-1388/ARN-82 (if installed).

(f) Adapter plate securing mounting MT-3600/ARN-82 to equipment shelf (if installed).

(3) Locate resistor R26 at rear of copilot's instrument panel. Remove wires L20C20 and F71B20 and F71B20 from R26. Remove and discard R26 and two mounting brackets. Reinstall two screws and two nuts in R26 mounting holes on instrument panel.

(4) Remove wire L20C20 from TB13, terminal 4. Discard wire.

(5) Remove wire going to post light on AAU-32/A Altimeter (L18F20 or L18G20) from TB13, terminal 10. Cut terminal lug from wire.

(6) Disconnect connector P506 from connector J506. Remove bolts securing static air manifold to frame. Lower manifold to gain access to connector J506. Remove J506 from mounting bracket for ease of work. Retain attaching hardware for reinstallation. Remove pin L and wire F71A20 from J506. Remove pin L and wire F71B20 from P506. Discard wire F71B20.

(7) At rear of copilot's instrument panel, disconnect connector P8002 from Altimeter-Encoder AAU-32/A. Remove pin Y and wire 1L18G20 from connector. Discard wire 1L18G20. At rear of pilot's instrument panel, locate connector P8004 from Altimeter AAU-31/A (if installed). Remove pin Y and wire 1L20G20 from connector and discard wire 1L20G20.

NOTE

The other end of wire 1L18G20 and 1L20G20 was previously capped and stowed per MWO 55-1500-219-30-4 (AIMS ALT).

(8) At aft wall (FS23) of nose compartment, locate main wire bundle running vertically (BL0). Loosen clamps (MS21919DG28) at WL36 and (MS21919DG16) at WL32. Wire bundle, consisting of seven wires, will be installed through these existing clamps in later step.

(9) Inside aircraft, accomplish the following:

(a) Remove windshield center post cover.

(b) Open overhead console covers.

(c) Remove two blank circuit breaker placards on aft row of pilot's panel (see Figure 2). Circuit breakers will be installed in later step.

(d) Remove post lights from Altimeter AAU-32/A location. Pull wire L18F20 or L18G20 through instrument panel. Discard wire and return post lights to stock.

b. Perform the following installations:

(1) Use mounting plate (1560-UH1-838) as a template for the following steps (a) through (f)..

(a) Position mounting plate as far aft as possible on right inner wall (RBL2) of the RT-742/ARC-51 enclosure in nose compartment (see Figure 3). Place approximately 1/2-inch from top of the wall (non-honey-combed section) between FS12 and FS20.

NOTE

The exact location of the mounting plates will differ due to variation in rivet patterns and lightening holes among different models of the UH-1.

(b) Clamp the mounting plate to the nose compartment wall. Avoid existing rivets or other obstructions. Check both sides of vertical wall to insure there will be no obstructions when installing the mounting hardware. The four mounting hole centers should be at least 7/8-inch from base of lightening hole flanges.

(c) Mark the nose compartment wall at each of the four predrilled corner holes in the mounting plate.

(d) Position the other mounting plate on the left outer wall (LBL10) of the RT-742/ARC-51 enclosure (see Figure 3).

NOTE

Avoid the Helicopter Identification plate on left outer wall of RT-742/ARC-51 enclosure when positioning mounting plate.

(e) Position template approximately 1/2-inch from top of wall between FS12 and FS20. Use the same procedure outlined in steps (b) and (c) above.

(f) Clamp the mounting base in place and mark nose compartment wall through the four predrilled holes.

(g) Using the mounting plates as templates, drill eight No. 2 (0.221 in. dia.) holes as marked. Remove mounting plates. Clean all burrs and chips from holes.

(h) Prepare areas around mounting holes (0.50 in. dia.) for electrical bonding by removing paint with sandpaper or equivalent. Polish with crocus cloth or equivalent using caution not to remove excessive metal.

(i) Apply a brush coating of Corrosion Resistant Coating (MIL-C-5541) to cleaned areas.

(2) Install 5-volt power supplies (1560-UH1-872) as follows:

(a) Assemble 5-volt power supply on each mounting plate (1560-UH1-838) using two bolts (AN-3CH20A) and two washers (MS15795-808) for the two mounting hole supply. For the four mounting hole supply, use four bolts (AN3CH3A) and four washers (MS15795-808). (See Figure 4). Lock wire using 0.032 safety wire to complete assembly.

(b) At connector end of power supplies, turn potentiometer adjustment screw (if provided) twelve full turns counterclockwise. (See Figure 4.)

(c) Install four standoffs (1560-UH1-830) on each mounting plate by inserting screw into internal thread of standoff through holes in mounting plate. Install with external threads facing away from power supply. Attach standoffs to mounting plate with four screws (MS35266-61) and washers (MS15795-808) (see Figure 5). Lock wire with 0.032 safety wire to complete assembly.

(d) With connector J13 facing aft, install mounting plate assembly on nose compartment wall (RBL2) at holes previously drilled. Secure using four lock nuts (MS21044-C3).

(e) Install remaining mounting plate assembly at left side of RT-742/ARC-51 enclosure with connector J14 facing aft. Complete installation in accordance with steps (c) and (d) above.

(f) Place decals (1560-UH1-869-1 and 1560-UH1-869-2) on walls at forward end of pilot and copilot power supplies.

(3) Install terminal board TB-100 (MS27212-1-10) as follows:

(a) Position TB100 no closer than 1/8-inch below mounting plate on right inner wall of RT-742/ARC-51 enclosure (see Figure 6). Align fore and aft, avoiding lightening holes at predrilled mounting holes in TB100.

(b) Mark nose compartment wall through mounting holes in TB100. Remove terminal board. Drill two No. 30 (0.1285 in. dia.) holes in wall. Place decal (1560-UH1-869-4) as shown in Figure 6.

NOTE

TB100 terminals are designated 1 thru 10 with terminal 1 at aft end and terminal 10 at forward end,

(c) Mount terminal board to wall using two screws (MS51956-15), two washers (MS35338-135), two washers (MS15795-803), two nuts (MS21044-L04).

(d) Place decal TB100 (1560-UH1-869-3) on nose compartment wall at aft end of terminal board (see Figure 6).

(e) Mount three hole bus bar (MS25226-2-3) on terminals 3, 4, 5 of TB100. Mount four hole bus bar (MS25226-2-4) on terminals 6,7,8,9. Install washer (AN960C6L), washer (AN935-6) and nut (MS21042-L06) on terminals 3, 4, 8, 9. Terminals 5, 6, 7 will have terminal lugs attached in a later step.

(4) Install wire harness (1560-UH1-865) as follows (see Figure 1):

(a) Mate connector P13 to J13 on pilot power supply and P14 to J14 on copilot power supply.

(b) Route wires L210B20 and L214B20 upward along main vertical wire bundle (BL0). Follow existing wire bundle to base of windshield center post. In cockpit, route wires along windshield center post to right overhead circuit breaker panel. (See Figure 2 for preferred circuit breaker locations.)

(c) Install two circuit breakers (MS22073-2-1/2) and two placards (1560-UH1-873-1), (1560-UH1-873-2) at locations shown in Figure 2. Remove existing bus bar. Install bus bar (1560-UH1-913) across all circuit breakers (except R1963 circuit breaker) in last row. Cut bus bar to correct length to cover all circuit breakers except R1963. If bus bar cannot be installed for any reason, then provide jumper wires to power 5-volt circuit breaker.

(d) Cut wires L210B20 and L214B20 to length and install two terminal lugs (MS25036-149). Attach wire L210B20 to pilot 5V circuit breaker and L214B20 to copilot 5V circuit breaker (load terminal).

(e) Route wire L211C20N upward along main vertical wire bundle to ground studs on horizontal brace between TB1 and TB29. Cut wire to length, install terminal lug (MS25036-103), and attach to ground stud.

(f) Route wires, L213A20 and L216A20 upward along main vertical wire bundle to connector J506. Cut wires to length, install two contacts (MS24255-20S) and connect as follows:

Wire Number	Connection
L213A20	Pin K
L216A20	Pin L

(g) Install contacts (MS24254-20P) on wires L213B20 and L216B20 (not part of wire harness 1560-UH1-865). Insert wire L213B20 in pin K of connector P506. Insert wire L216B20 in pin L of P506.

(h) Route wires L213B20 and L216B20 along wire bundle at rear of instrument panel to TB13. Cut wires to length and install two terminal lugs (MS25036-102). Connect wire L213B20 to terminal 4 TB13. Connect wire L216B20 to terminal 11 TB13.

(i) Route wire L215B20 to connector P8002 (Altimeter-Encoder AAU-32/A) at rear of copilot's instrument panel. Cut wire to length and install contact (MS24255-20S). Insert L215B20 in connector P8002 as pin Y. Route wire L215D20 to connect P8004 (Counter Drum Pointer AAU-31A) at rear of pilot's instrument panel. Cut wire to length and install contact (MS24255-20S). Insert L215D20 in connector P8004 in pin Y. Locate wires from pin X, P8002, SX705P20N and pin X, P8004, SX705L20N, and route to ground stud near TB29. Attach terminal lugs (MS25036-103) and attach to ground stud (these wires were previously capped and stowed with application of MWO 55-1520-210-30-4, AIMS altimeter).

(j) At connector P403 (pilot's RMI), unsolder wire F71A20 from pin 35. Discard wire. Route wire L212B20 to connector P403 and cut to length. Install heat shrink tubing (RNF-100) and solder to pin 35-P403.

(k) Install clamp (MS21919DG3) on wire bundle leading from 5-volt power supply (copilot) as shown in Figure 1, detail B. Clamp is added to existing clamp at aft end of ARC-51 enclosure.

(l) Install clamp (MS21919DG5) on wire bundle leading to TB100. Locate clamp right side of ARC-51 enclosure, aft of connector P 13 (see Figure 1, detail A).

(m) Install clamp (MS21919DG5) on wire bundle leading to TB100. Locate clamp on right side of ARC-51 enclosure, aft of connector P13 (see Figure 1, detail A).

(n) Cut the following wires to length and install terminal lug (MS25036-102) on each wire. Connect to TB100 using two flat washers (AN960C6L), lock washer (AN935-6), lock nut (MS21042-L06) at each terminal indicated.

Wire Number	TB100 Terminal
L210A20	1
L210B20	1
L214A20	2
L214B20	2
L215D20	5
L212A20	5
L212B20	5

Wire Number	TB100 Terminal
L215A20	6
L215B20	7
L211A20	10
L211B20	10
L211C20N	10

c. Complete modification as follows:

(1) Perform the following functional test by checking continuity, using multimeter TS-352B/U or equivalent:

From	To	Reading - (OHMS)
P13 - Pin A	TB100 Terminal 1	0
P13 - Pin B	TB100 Terminal 10	0
P13 - Pin C	TB100 Terminal 5	0
P13 - Pin E	TB13 Terminal 4	0
P14 - Pin A	TB100 Terminal 2	0
P14 - Pin B	TB100 Terminal 10	0
P14 - Pin C	TB100 Terminal 6	0
P14 - Pin E	TB13 Terminal 11	0
TB100 Terminal 1	DC circuit breaker 5V Pilot	0
TB100 Terminal 2	DC circuit breaker 5V Copilot	0
TB100 Terminal 5	ID-998/ASN connector P403 pin 35	0
TB100 Terminal 5	AAU-31/A connector P8004 pin Y	0
TB100 Terminal 7	AAU-32/A connector P8002, pin Y	0
TB100 Terminal 10	Frame Ground	0

(2) Connect P403 to ID-998, P8002 to AAU-32/A and P8004 to AAU-31.

(3) Turn pilot's instrument light rheostats to OFF.

(4) Reinstall battery and place battery switch to ON position. Energize pilot and copilot 5-volt circuit breakers.

(5) Turn pilot's and copilot's instrument lights rheostats R4 and R10 to maximum brightness. Adjust potentiometer on copilot 5V power supply clockwise until intensity of AAU-32 Altimeter lighting is equal to intensity of other copilot instrument lights. Adjust potentiometer on pilot 5V power supply clockwise until intensity of ID-998/ASN lighting is equal to intensity of other pilot instrument lights.

(6) Rotate the copilot's instrument lights rheostat R10 counterclockwise. Check that the AAU-32/A Altimeter light varies in the same intensity as the other copilot instrument lights.

(7) Rotate the pilot's instrument lights rheostat R4 counterclockwise. Check that the ID-998/ASN light varies in the same intensity as the other pilot instrument lights.

(8) Place battery switch in OFF position. Install terminal board cover (MS18029-11S-10) on TB100.

(9) Inspect all wire bundles and remove all temporary ties. Lace and/or tie wire bundles in accordance with TM 55-1500-323-25. Secure bundles using existing cable clamps and existing cable clamps and existing holes where possible.

(10) Replace all components or assemblies removed for access.

(11) Perform a functional check of communications, navigation and electrical systems affected by this modification.

11. Calibration Requirements. Not applicable.

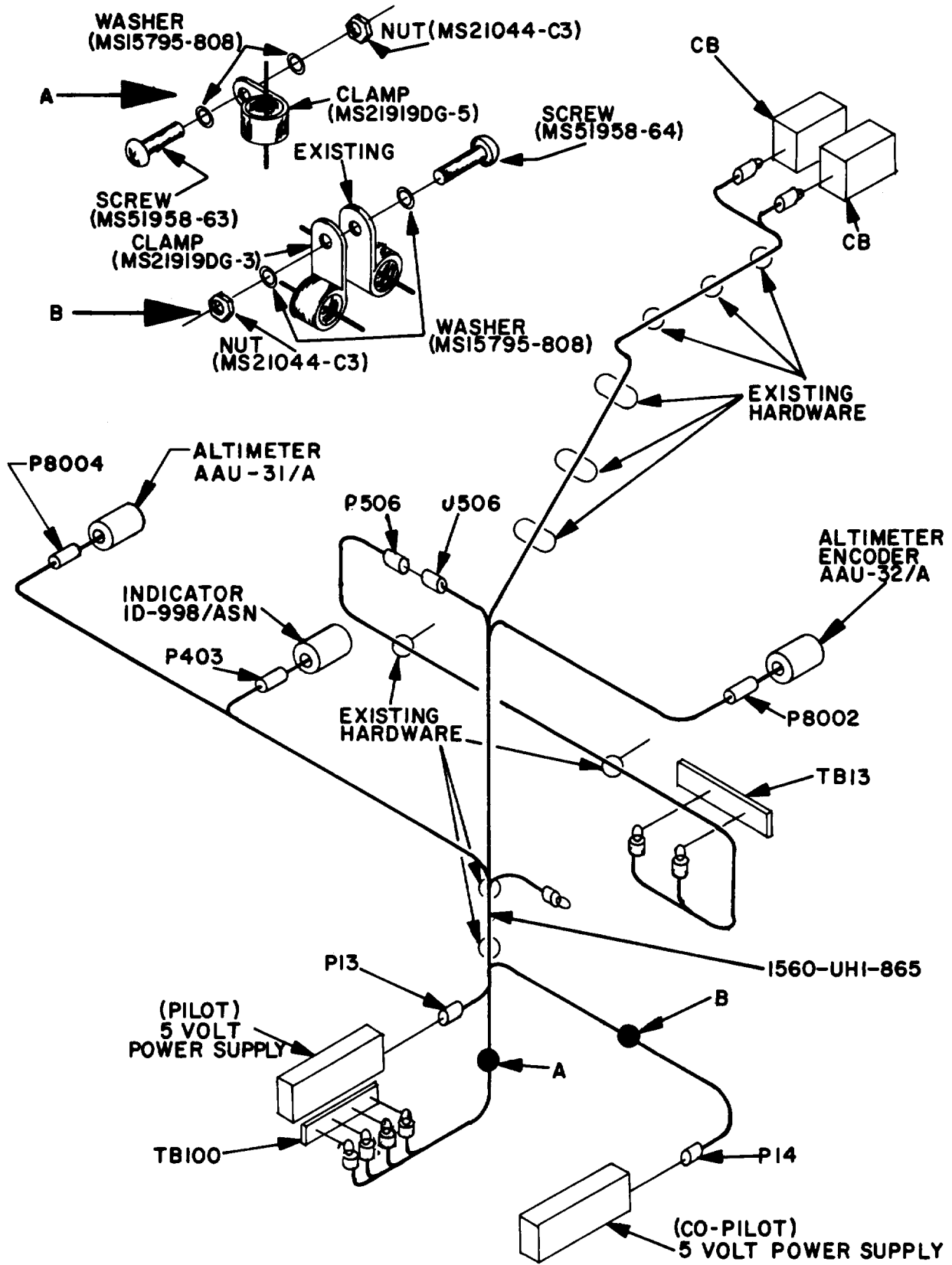

Figure 1. Wire harness installation detail.

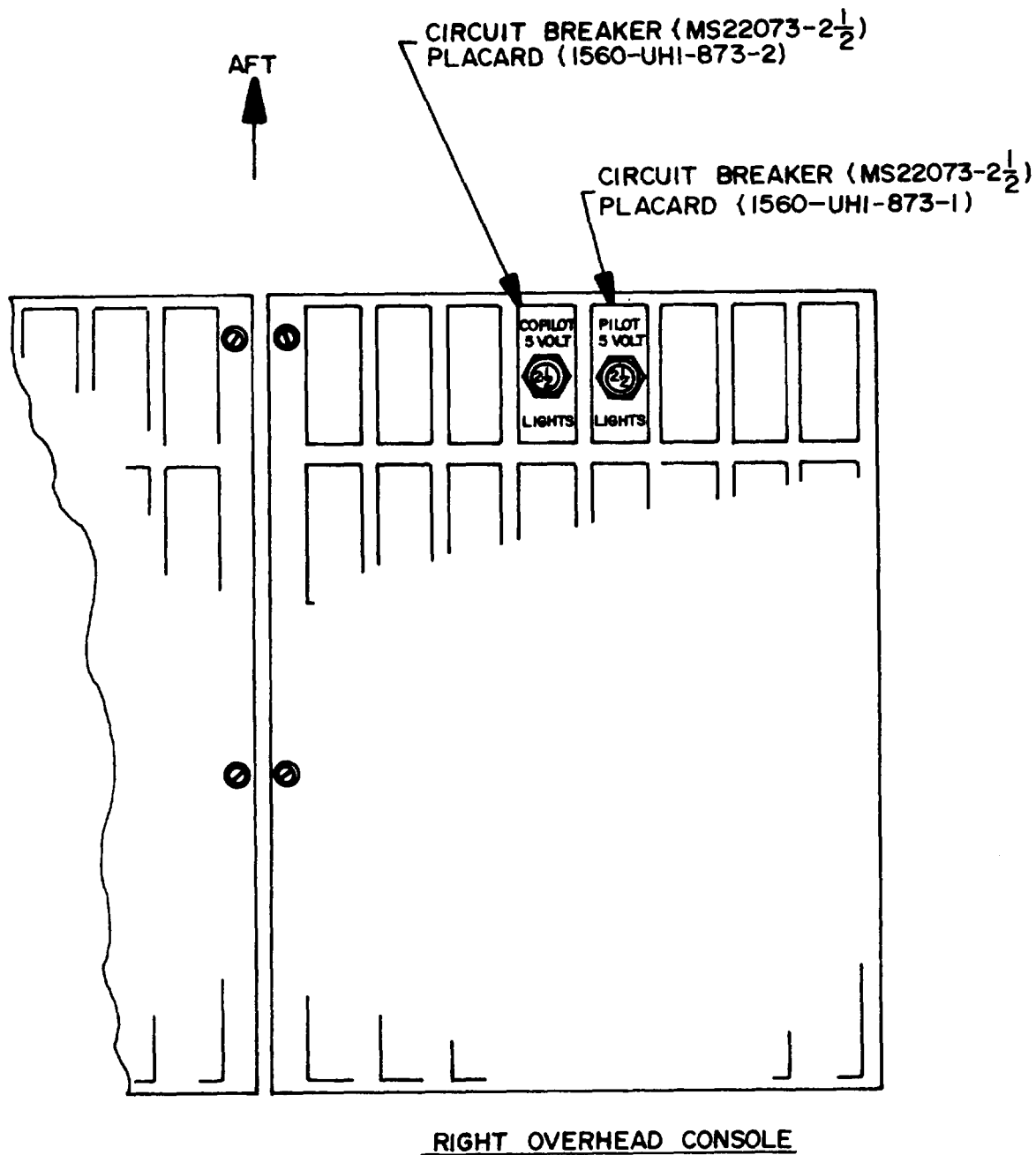
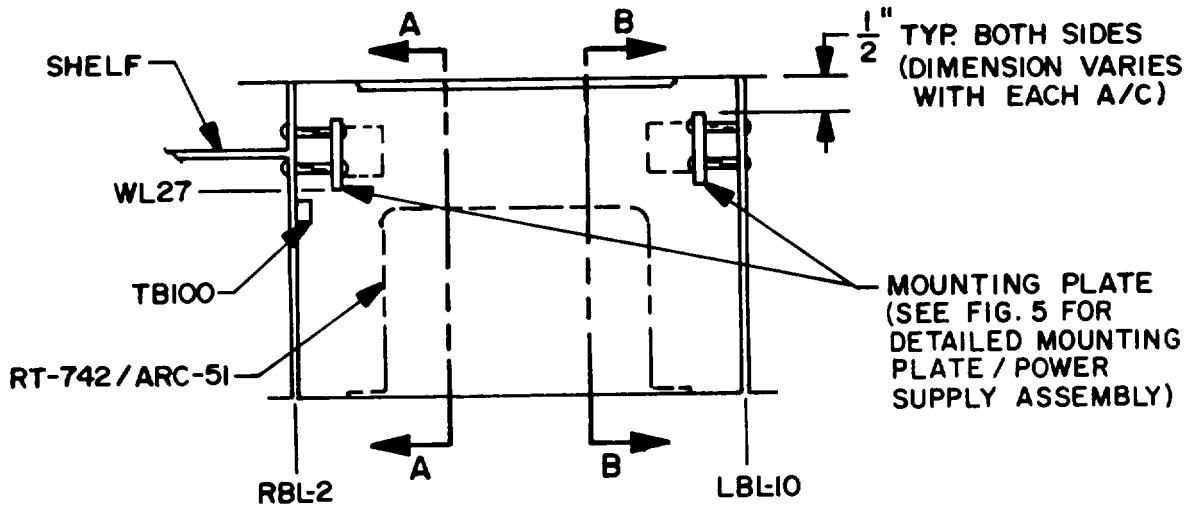
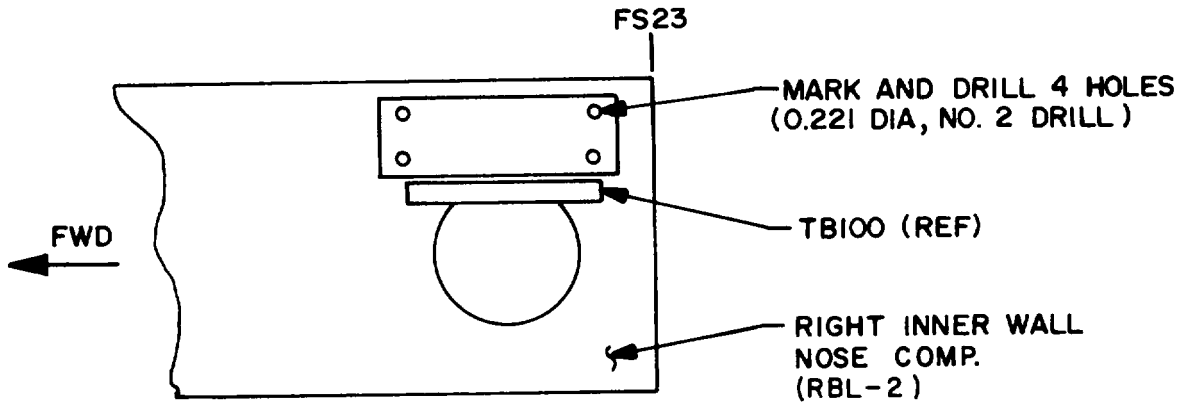

Figure 2. DC circuit breaker location- typical.



FRONT VIEW OF ARC-51 ENCLOSURE



VIEW A-A

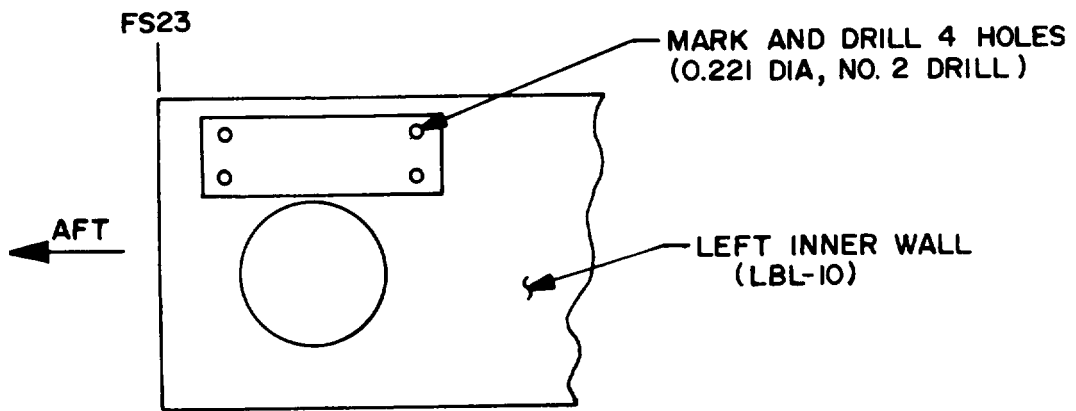

VIEW B-B

Figure 3. Location of mounting plates (1560-838)- typical.

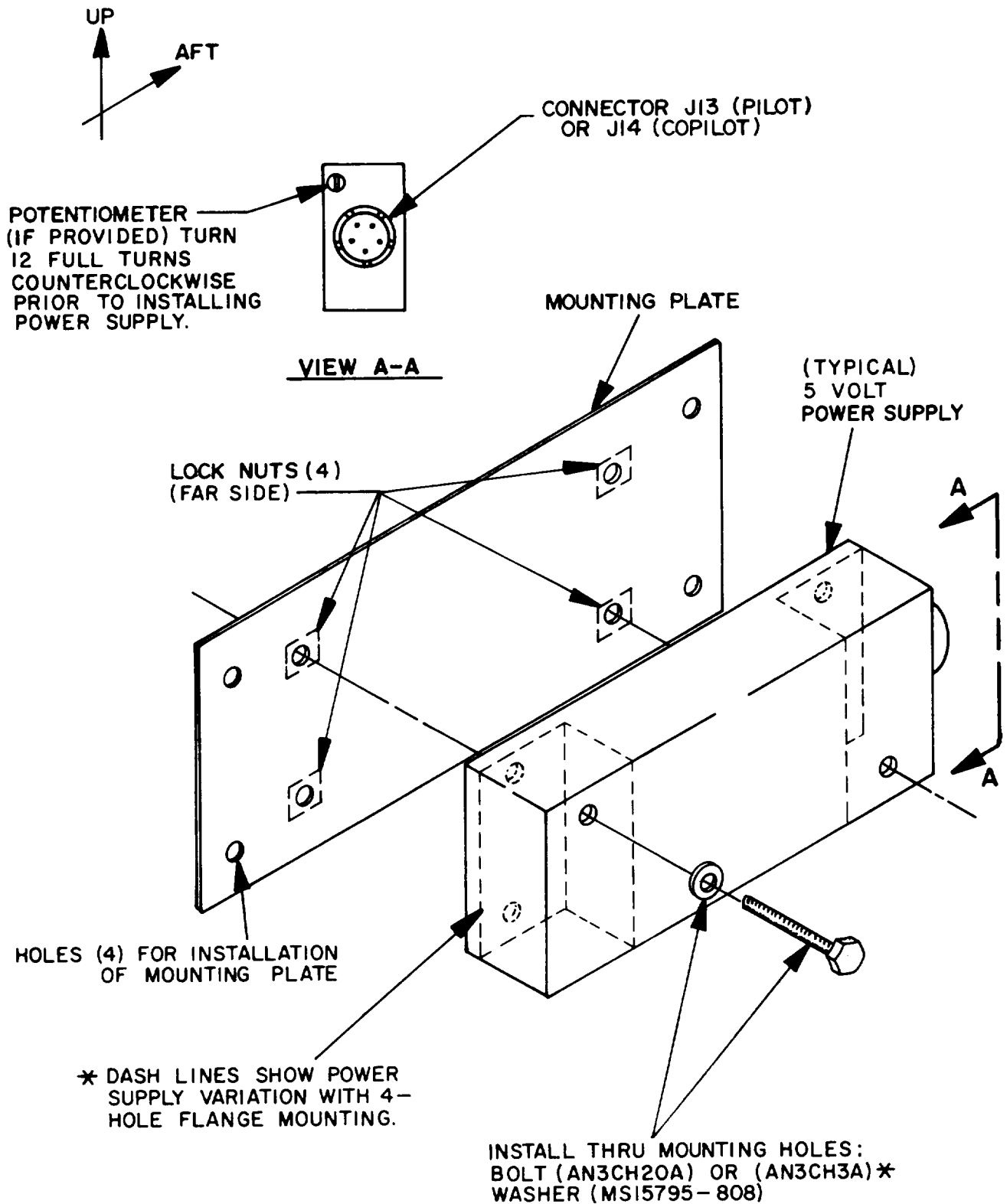

Figure 4. Assembly of 5 volt power supply on mounting plate.

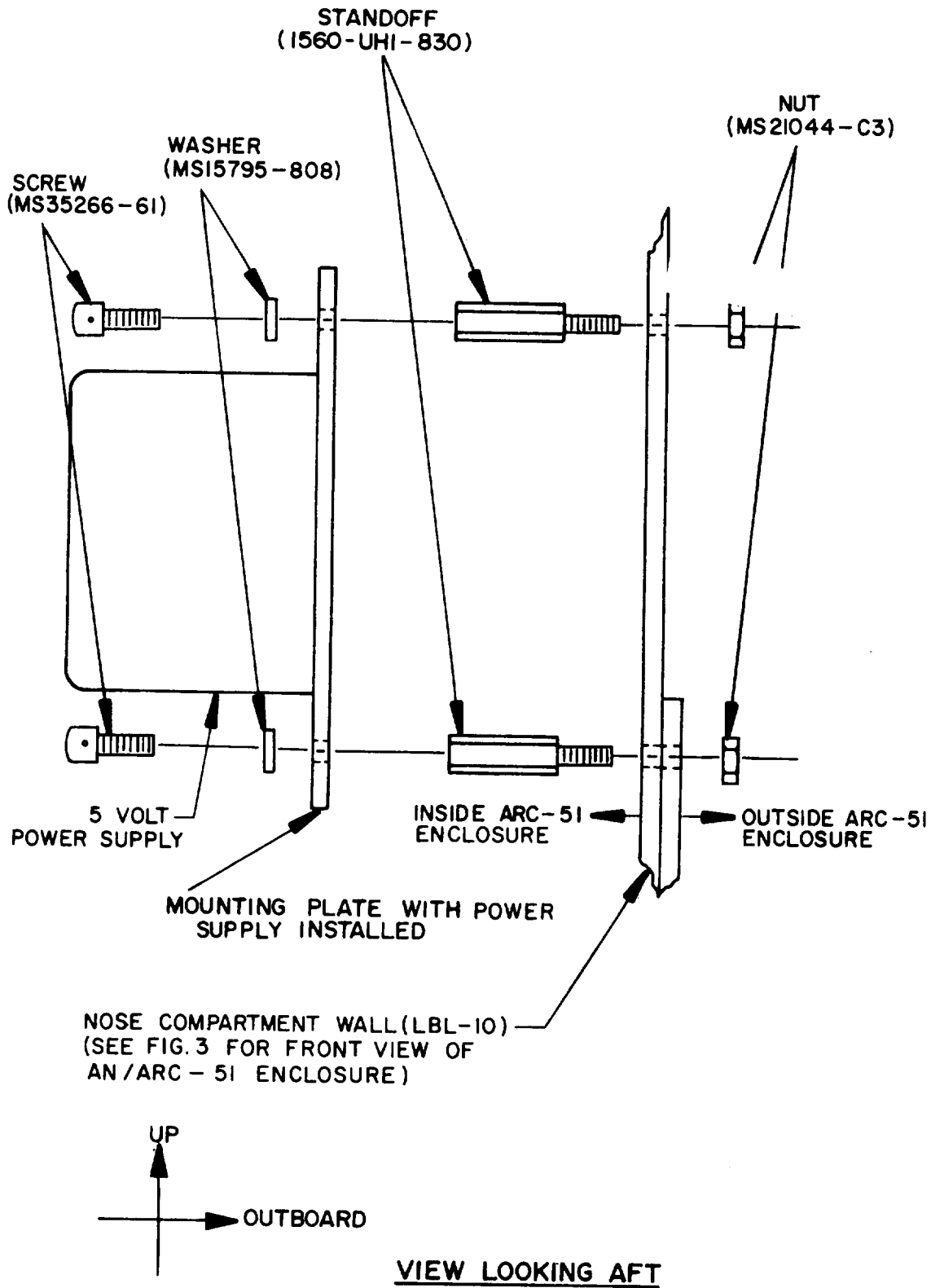

Figure 5. Installation of mounting plate/power supply assembly- typical.

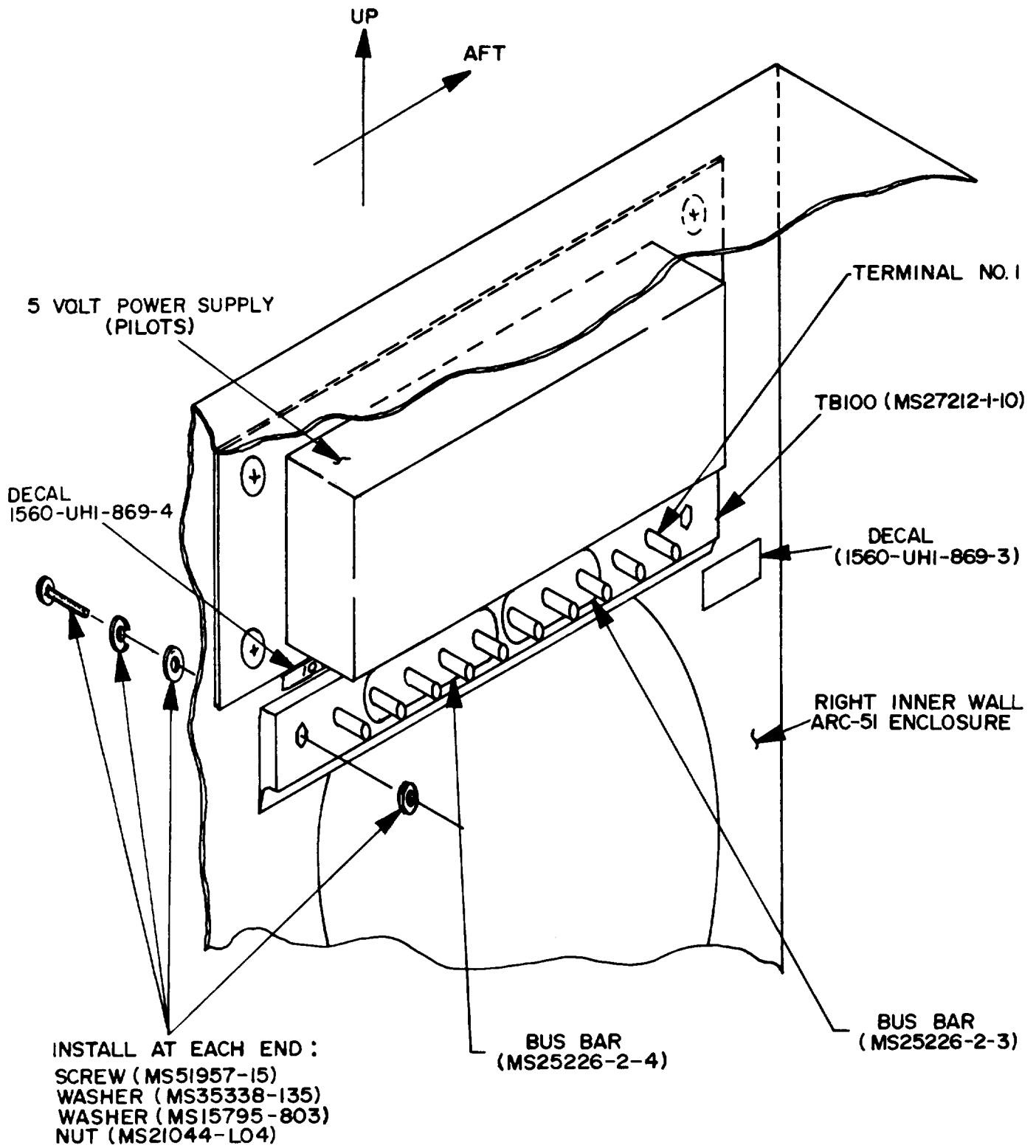

Figure 6. TB-100 installation- typical.

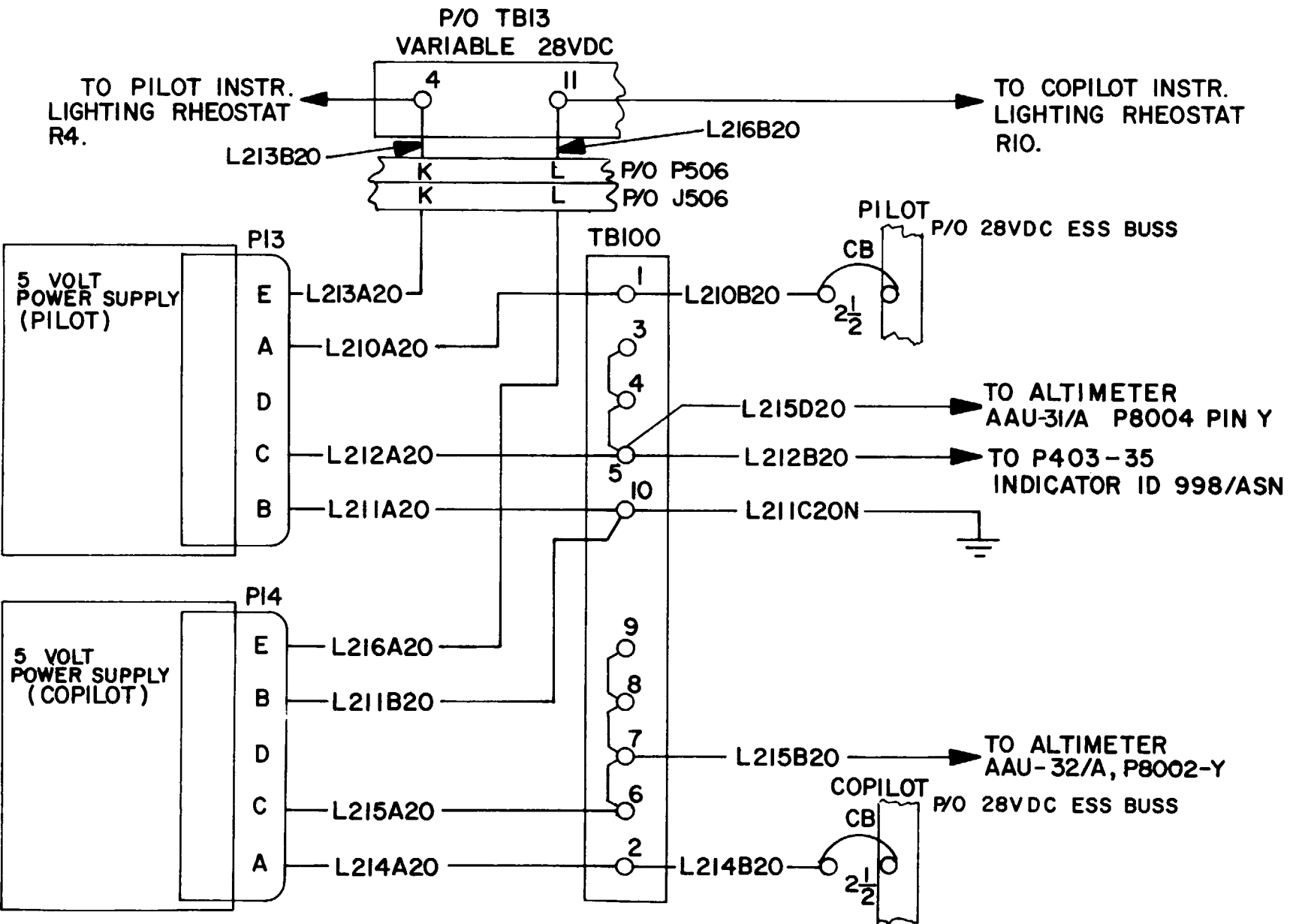

Figure 7. Interface wiring diagram 5 volt power supplies.

12. Weight and Balance Data. Weight and balance change as a result of this MWO is as follows:

- a. Change in basic weight +3.3 lbs.
- b. Moment arm 14 in.
- c. Change in basic moment 46.2 in. lbs.
- d. Chart "A" entries (DD Form 365A, Basic Weight Checklist)

Compartment		Wt. (lbs)	Arm (in.)	Moment/100 in. lbs.)
A	5-Volt Power Supply (pilot)	1.1	14	0.15
A	5-Volt Power Supply (copilot)	1.1	14	0.15
A	Mounting Plate	0.3	14	0.04
A	Mounting Plate	0.3	14	0.04
A	Wiring Harness	0.5	14	0.07

- e. Chart "A" deletions: None
- f. Chart "C" entry (DD Form 365C Basic Weight and Balance Record),

Added Weight	Arm (in.)	Moment/100
3.3	14	0.5

13. Quality Assurance Requirements. Inspection of complete MWO application for full compliance with the technical requirements of the instructions will be accomplished by qualified personnel in accordance with an approved prescribed inspection system. The inspection, in effect, will be determined on the basis of instructions issued at the site of work; i.e., Army ORG/DS/GS, Army depot, contractor, etc.

14. Recording and Reporting of the Modification. Record accomplishment of the modification in accordance with the procedures prescribed in TM 38-750. The following forms are applicable: DA Form 2407 (Maintenance Request), DA Form 2408-5 (Equipment Modification Record-Aircraft), DA Form 2408-13 (Aircraft Inspection and Maintenance Record). After completing the DA Form 2407, mail the NMP Copy (Copy No. 2) to Commander, US Army Troop Support & Aviation Materiel Readiness Command (TSARCOM), ATTN: DRSTS-MDO(1), 4300 Goodfellow Boulevard, St. Louis, MO 63120. If the application is accomplished by field personnel under a negotiated MOU and requires reimbursement, mail the Control Copy (Copy No. 3) to Commander, US Army Depot System Command (DESCOM) ATTN: DRSDS-PM, Chambersburg, PA 17201. Procurement Request Order Number (PRON), Memorandum of Understanding (MOU) Number and fiscal station code will be annotated in Block No. 35. If application is accomplished by depot or contractor teams, Copy No. 3 will not be submitted to DESCOM and maybe disposed of in accordance with TM 38-750.

15. Product Improvement Proposal (PIP Number). PIP No. 1-72-01-0027 is authority for this MWO.

By Order of the Secretary of the Army:

E. C. MEYER
General United States Army
Chief of Staff

Official:

J. C. PENNINGTON
Major General, United States Army
The Adjutant General

DISTRIBUTION:

To be distributed in accordance with DA Form 12-31, MWO requirements for UH-1D/UH-1H Aircraft.



SOMETHING WRONG WITH THIS MANUAL?

THEN...JOT DOWN THE DOPE ABOUT IT ON THIS FORM. TEAR IT OUT, FOLD IT AND DROP IT IN THE MAIL!

FROM: (YOUR UNIT'S COMPLETE ADDRESS)
 PFC JOHN DOE
 COA, 3^d ENGINEER BN
 FT. LEONARD WOOD MO 63108

DATE

PUBLICATION NUMBER

DATE

TITLE

MWD 55-150-219-30-135 July 1980

Installation of 5-7olt Instrument Lighting System UH-1H Helicopter (Medical)

BE EXACT...PIN-POINT WHERE IT IS

IN THIS SPACE TELL WHAT IS WRONG AND WHAT SHOULD BE DONE ABOUT IT:

PAGE NO.	PARA-GRAPH	FIGURE NO.	TABLE NO.
6	2-1 a		
81		4-3	
125	line 20		

In line 6 of paragraph 2-1a the manual states the engine has 6 cylinders. The engine on my set only has 4 cylinders. Change the manual to show 4 cylinders.

Callout 16 on figure 4-3 is pointing at a bolt. In the key to fig. 4-3, item 16 is called a skim. Please correct one or the other.

Ordered a gasket, item 19 on figure B-16 by NSN 2910-00-762-3001. I got a gasket but it doesn't fit. Supply says I got what I ordered, so the NSN is wrong. Please give me a good NSN.

SAMPLE

TYPED NAME, GRADE OR TITLE, AND TELEPHONE NUMBER

JOHN DOE, PFC (268) 317-7111

SIGN HERE:

John Doe

TEAR ALONG DOTTED LINE

FILL IN YOUR
UNIT'S ADDRESS

FOLD BACK

DEPARTMENT OF THE ARMY

POSTAGE AND FEES PAID
DEPARTMENT OF THE ARMY
DOD-314

OFFICIAL BUSINESS

PENALTY FOR PRIVATE USE, \$300

Commander:
U.S. Army Support and Aviation
Material Readiness Command
ATTN: DRSTS-MTPS
4300 Goodfellow Boulevard
St. Louis, Mo. 63120

TEAR ALONG DIVISION LINE

FOLD BACK



SOMETHING WRONG WITH THIS MANUAL?

THEN... JOT DOWN THE DOPE ABOUT IT ON THIS FORM, TEAR IT OUT, FOLD IT AND DROP IT IN THE MAIL!

FROM: (YOUR UNIT'S COMPLETE ADDRESS)

DATE

PUBLICATION NUMBER

DATE

TITLE

MWO 55-1500-219-30-8

25 July 80

Installation of 5 Volt Instrument Lighting System in UH-1H Helicopters

BE EXACT... PIN-POINT WHERE IT IS

IN THIS SPACE TELL WHAT IS WRONG AND WHAT SHOULD BE DONE ABOUT IT:

PAGE NO.	PARA-GRAPH	FIGURE NO.	TABLE NO.
----------	------------	------------	-----------

TEAR ALONG DOTTED LINE

TYPED NAME, GRADE OR TITLE, AND TELEPHONE NUMBER

SIGN HERE:

FILL IN YOUR
UNIT'S ADDRESS

FOLD BACK

DEPARTMENT OF THE ARMY

POSTAGE AND FEES PAID
DEPARTMENT OF THE ARMY
DOD-314

OFFICIAL BUSINESS

PENALTY FOR PRIVATE USE, \$300

Commander:
U.S. Army Support and Aviation
Material Readiness Command
ATTN: DRSTS-MTPS
4300 Goodfellow Boulevard
St. Louis, Mo. 63120

TEAR ALONG OUTER LINE

FOLD BACK



SOMETHING WRONG WITH THIS MANUAL?

THEN... JOT DOWN THE DOPE ABOUT IT ON THIS FORM, TEAR IT OUT, FOLD IT AND DROP IT IN THE MAIL!

FROM: (YOUR UNIT'S COMPLETE ADDRESS)

DATE

PUBLICATION NUMBER

DATE

TITLE

MWO 55-1500-219-30-8

25 July 80

Installation of 5 Volt Instrument Lighting System in UH-1H Helicopters

BE EXACT... PIN-POINT WHERE IT IS

IN THIS SPACE TELL WHAT IS WRONG AND WHAT SHOULD BE DONE ABOUT IT:

PAGE NO.

PARA-GRAPH

FIGURE NO.

TABLE NO.

TEAR ALONG DOTTED LINE

TYPED NAME, GRADE OR TITLE, AND TELEPHONE NUMBER

SIGN HERE:

DA FORM 1 AUG 74 **2028-2**

P.S.--IF YOUR OUTFIT WANTS TO KNOW ABOUT YOUR MANUAL "FIND," MAKE A CARBON COPY OF THIS AND GIVE IT TO YOUR HEADQUARTERS.

FILL IN YOUR
UNIT'S ADDRESS

FOLD BACK

DEPARTMENT OF THE ARMY

POSTAGE AND FEES PAID
DEPARTMENT OF THE ARMY
DOD-314

OFFICIAL BUSINESS

PENALTY FOR PRIVATE USE, \$300

Commander:
U.S. Army Support and Aviation
Material Readiness Command
ATTN: DRSTS-MTPS
4300 Goodfellow Boulevard
St. Louis, Mo. 63120

TEAR ALONG DOTTED LINE

FOLD BACK

RECOMMENDED CHANGES TO EQUIPMENT TECHNICAL MANUALS



SOMETHING WRONG WITH THIS MANUAL?

THEN... JOT DOWN THE DOPE ABOUT IT ON THIS FORM, TEAR IT OUT, FOLD IT AND DROP IT IN THE MAIL!

FROM: (YOUR UNIT'S COMPLETE ADDRESS)

DATE

PUBLICATION NUMBER

DATE

TITLE

MWO 55-1500-219-30-8

25 July 80

Installation of 5 Volt Instrument Lighting System IN UH-1H Helicopters

BE EXACT... PIN-POINT WHERE IT IS

IN THIS SPACE TELL WHAT IS WRONG AND WHAT SHOULD BE DONE ABOUT IT:

PAGE
NO.

PARA-
GRAPH

FIGURE
NO.

TABLE
NO.

TEAR ALONG DOTTED LINE

TYPED NAME, GRADE OR TITLE, AND TELEPHONE NUMBER

SIGN HERE:

DA FORM 2028-2
1 AUG 74

P.S.--IF YOUR OUTFIT WANTS TO KNOW ABOUT YOUR MANUAL "FIND," MAKE A CARBON COPY OF THIS AND GIVE IT TO YOUR HEADQUARTERS.

FILL IN YOUR
UNIT'S ADDRESS

FOLD BACK

DEPARTMENT OF THE ARMY

POSTAGE AND FEES PAID
DEPARTMENT OF THE ARMY
000-314

OFFICIAL BUSINESS

PENALTY FOR PRIVATE USE, \$300

Commander
US Army Troop Support and Aviation
Materiel Readiness Command
ATTN: DRSTS-MTPS
4300 Goodfellow Boulevard
St. Louis, MO 63120

TEAR ALONG DOTTED LINE

FOLD BACK

