

TECHNICAL MANUAL

AVIATION UNIT AND INTERMEDIATE  
MAINTENANCE INSTRUCTIONS  
ARMY MODEL UH-1H/V/EH-1H/X

This manual supersedes TM 55-1520-210-23-3, 20 February 1979, including all changes.

---

HEADQUARTERS, DEPARTMENT OF THE ARMY  
30 SEPTEMBER 1987



CHANGE

NO. 8

HEADQUARTERS  
DEPARTMENT OF THE ARMY  
WASHINGTON, D.C., 14 June 1996

**Aviation Unit and Intermediate  
Maintenance Instructions**

**ARMY MODEL UH-IHNIEH-IHIX HELICOPTERS**

DISTRIBUTION STATEMENT A: Approved for public release; distribution is unlimited.

TM 55-1520-210-23-3, 30 September 1987, is changed as follows:

1. Remove and insert pages as indicated below. New or changed text material is indicated by a vertical bar in the margin. An illustration change is indicated by a miniature pointing hand.

**Remove pages**

i and ii  
A-1 through A-3/(A-4 blank)  
B-9 and B-10  
B-55 through B-58  
C-1 through C-10  
D-3 and D-4  
D-53 and D-54  
D-68.1 and D-68.2  
D-69 and D-70  
D-73 and D-74  
D-79 and D-80  
D-85 and D-86  
D-90.3/(D-90.4 blank)  
D-115 and D-116  
D-199 and D-200  
D-389 and D-390

---

F-1 and F-2

---

F-77 and F-78  
Index 5 and Index 6  
Index 9 and Index 10

**Insert pages**

i and ii  
A-1 through A-3/(A-4 blank)  
B-9 and B-10  
B-55 through B-58  
C-1 through C-10  
D-3 and D-4  
D-53 and D-54  
D-68.1 and D-68.2  
D-69 and D-70  
D-73 and D-74  
D-79 and D-80  
D-85/(D-86 blank)  
D-90.3/(D-90.4 blank)  
D-115 and D-116  
D-199 and D-200  
D-389 and D-390  
D-445/(D-446 blank)  
F-1 and F-2  
F-76.1/(F-76.2 blank)  
F-77 and F-78  
Index 5 and Index 6  
Index 9 and Index 10

TM 55-1520-210-23-3  
C8

**Remove pages**

\_\_\_\_\_

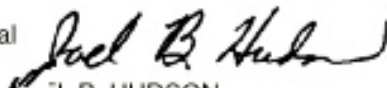
**Insert pages**

Electronic 2028 Instructions

3. Retain this sheet in front of manual for reference purposes.

By Order of the Secretary of the Army:

Official



JOEL B. HUDSON

*Administrative Assistant to the  
Secretary of the Army*  
01972

DENNIS J. REIMER  
*General, United States Army  
Chief of Staff*

**DISTRIBUTION:**

To be distributed in accordance with DA Form 1231E, block no. 1408, requirements for TM 551520210233.



CHANGE

NO. 7

HEADQUARTER  
DEPARTMENT OF THE ARMY  
WASHINGTON, D.C., 31 July 1995

Aviation Unit and Intermediate  
Maintenance Instructions

ARMY MODEL UH-1H/V/EH-1H/X  
HELICOPTERS

DISTRIBUTION STATEMENT A: Approved for public release; distribution is unlimited

TM 55-1520-210-23-3, 30 September 1987, is changed as follows:

1. Remove and insert pages as indicated below. New or changed text material is indicated by a vertical bar in the margin. An illustration change is indicated by a miniature pointing hand.

Remove pages

Insert pages

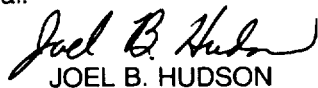
Index 5 and Index 6

Index 5 and Index 6

2. Retain this sheet in front of manual for reference purposes.

By Order of the Secretary of the Army:

Official:

  
JOEL B. HUDSON

Acting Administrative Assistant to the  
Secretary of the Army  
00485

DENNIS J. REIMER  
General, United States Army  
Chief of Staff

DISTRIBUTION:

To be distributed in accordance with DA Form 12-31-E, block no. 1408, requirements for  
TM 55-1520-210-23-3.



# URGENT

TM 55-1520-210-23-3  
C 6

CHANGE

NO. 6

HEADQUARTERS  
DEPARTMENT OF THE ARMY  
WASHINGTON, D.C., 31 May 1994

Aviation Unit and Intermediate  
Maintenance Instructions

ARMY MODEL UH-1H/V/EH-1H/X

DISTRIBUTION STATEMENT A: Approved for public release; distribution is unlimited.

TM 55-1520-210-23-3, 30 September 1987, is changed as follows:

1. Remove and insert pages as indicated below. New or changed text material is indicated by a vertical bar in the margin. An illustration change is indicated by a miniature pointing hand.

Remove pages

E-3 and E-4

E-5 and E-6

F-82.1/(F-82.2 blank)

Insert pages

E-3 and E-4

E-5 and E-6

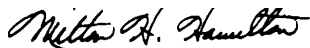
F-82.1/(F-82.2 blank)

2. Retain this sheet in front of manual for reference purposes.

By Order of the Secretary of the Army:

GORDON R. SULLIVAN  
General, United States Army  
Chief of Staff

Official:



MILTON H. HAMILTON  
Administrative Assistant to the  
Secretary of the Army  
06213

DISTRIBUTION :

To be distributed in accordance with DA Form 12-31-E, block no. 1408, requirements for TM 55-1520-210-23-3.



CHANGE

NO. 5

HEADQUARTERS  
DEPARTMENT OF THE ARMY  
WASHINGTON, D.C., 15 OCTOBER 1993

Aviation Unit and Intermediate  
Maintenance Instructions

ARMY MODEL UH-1H/V/EH-1H/X

DISTRIBUTION STATEMENT A: Approved for public release; distribution is unlimited.

TM 55-1520-210-23-3, 30 September 1987, is changed as follows:

- To correct change 4 remove and insert page, disregard inserting page D-396.1/D-396.2. This page does not exist.
- Remove and insert pages as indicated below. New or changed text material is indicated by a vertical bar in the margin. An illustration change is indicated by a miniature pointing hand.

## Remove pages

i and ii  
A-1 through A-3/  
(A-4 blank)  
B-19 and B-20  
B-63 and B-64  
B-79 through B-82  
C-1 and C-2  
D-1 through D-4  
D-5 and D-6  
D-9 through D-14  
D-62.1 and D-62.2  
D-67 and D-68  
D-68.1 and D-68.2  
D-69 and D-70  
D-90.3/(D-90.4 blank)  
D-127 and D-128  
D-183 and D-184  
D-373 and D-374  
D-405 and D-406  
D-433 and D-434  
D-441 through D-443/  
(D-444 blank)  
F-93/(F-94 blank)  
Index 5 and Index 6

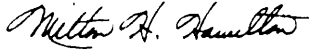
## Insert pages

i and ii  
A-1 through A-3/  
(A-4 blank)  
B-19 and B-20  
B-63 and B-64  
B-79 through B-82  
C-1 and C-2  
D-1 through D-4  
D-5 and D-6  
D-9 through D-14  
D-62.1 and D-62.2  
D-67 and D-68  
D-68.1 and D-68.2  
D-69 and D-70  
D-90.3/(D-90.4 blank)  
D-127 and D-128  
D-183 and D-184  
D-373 and D-374  
D-405 and D-406  
D-433 and D-434  
D-441 through D-444  
F-93/(F-94 blank)  
Index 5 and Index 6

- Retain this sheet in manual for reference purposes.

By Order of the Secretary of the Army:

Official:



MILTON H. HAMILTON  
Administrative Assistant to the  
Secretary of the Army

05619

GORDON R. SULLIVAN  
General, United States Army  
Chief of Staff

DISTRIBUTION:

To be distributed in accordance with DA Form 12-31-E, block no. 1408, requirements for TM 55-1520-210-23-3.

CHANGE }  
NO. 4 }

HEADQUARTERS  
DEPARTMENT OF THE ARMY  
WASHINGTON, D.C., 30 SEPTEMBER 1991

Aviation Unit and Intermediate  
Maintenance Instructions

ARMY MODEL UH-1H/V/EH-1H/X Helicopters

TM 55-1520-210-23-3, 30 September 1987, is changed as follows:

1. Remove and insert pages as indicated below. New or changed text material is indicated by a vertical bar in the margin. An illustration change is indicated by a miniature pointing hand.

Remove pages	Insert pages
A-1 through A-3/A-4	A-1 through A-3/A-4
B-3 and B-4	B-3 and B-4
B-17 through B-20	B-17 through B-20
B-23 and B-24	B-23 and B-24
B-27 and B-28	B-27 and B-28
B-29 and B-30	B-29 and B-30
B-55 and B-56	B-55 and B-56
B-69 and B-70	B-69 and B-70
B-70.1 through B-70.8	- - -
B-77 and B-78	B-77 and B-78
C-1 through C-6	C-1 through C-10
D-1 through D-4	D-1 through D-4
D-5 and D-6	D-5 and D-6
- - -	D-6.1/D-6.2
D-9 through D-14	D-9 through D-14
D-67 and D-68	D-67 and D-68
D-68.1 and D-68.2	D-68.1 and D-68.2
D-69 and D-70	D-69 and D-70
D-73 through D-90	D-73 through D-90
D-90.1 and D-90.2	D-90.1 through D-90.3/D-90.4
D-175 and D-176	D-175 and D-176
D-183 and D-184	D-183 and D-184
D-213 and D-214	D-213 and D-214
D-247 and D-248	D-247 and D-248
D-339 and D-340	D-339 and D-340
D-373 and D-374	D-373 and D-374
D-379 and D-380	D-379 and D-380
D-389 and D-390	D-389 and D-390
- - -	D-396.1/D-396.2
D-397 and D-398	D-397 and D-398
D-429/D-430	D-429 through D-441/D-442
E-3 and E-4	E-3 and E-4
E-7 through E-10	E-7 through E-10
E-11 and E-12	E-11 and E-12
F-23 and F-24	F-23 and F-24

Remove pages

F-51 and F-52  
F-75/F-76  
- - -  
F-99/F-100  
F-113 and F-114  
Index 1 through Index 13

Insert pages

F-51 and F-52  
F-75/F-76  
F-82.1/F-82.2  
F-99/F-100  
F-113 and F-114  
Index 1 through Index 14

2. Retain this sheet in front of manual for reference purposes.

By Order of the Secretary of the Army:

Official:

PATRICIA P. HICKERSON  
*Colonel, United States Army*  
*The Adjutant General*

GORDON R. SULLIVAN  
*General, United States Army*  
*Chief of Staff*

DISTRIBUTION:

To be distributed in accordance with DA Form 12-31-E, block no., 1408, AVUM and AVIM maintenance requirements for TM 55-1520-210-23-3.



**URGENT**CHANGE }  
NO. 3 }HEADQUARTERS  
DEPARTMENT OF THE ARMY  
WASHINGTON, D.C., 30 March 1990Aviation Unit and Intermediate  
Maintenance Instructions

## ARMY MODEL UH-1H/V/EH-1H/X Helicopters

TM 55-1520-210-23-3, 30 September 1987, is changed as follows:

1. Remove and insert pages as indicated below. New or changed text material is indicated by a vertical bar in the margin. An illustration change is indicated by a miniature pointing hand.

Remove pages

Insert pages

D-1 and D-2

D-1 and D-2

-----

D-429/D-430

E-1 through E-4

E-1 through E-4

2. Retain this sheet in front of manual for reference purposes.

By Order of the Secretary of the Army:

CARL E. VUONO  
General, United States Army  
Chief of Staff

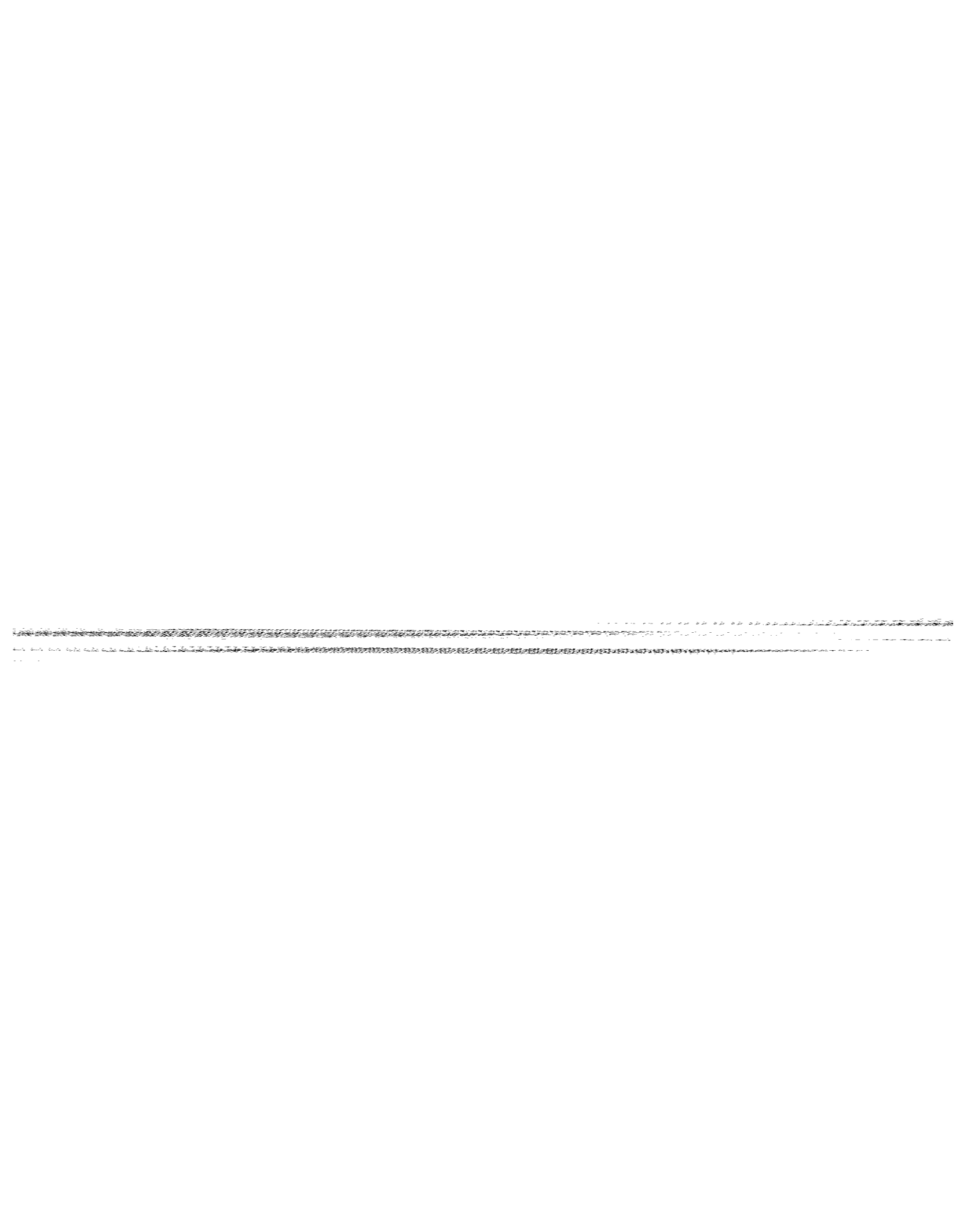
Official:

WILLIAM J. MEEHAN II  
Brigadier General, United States Army  
The Adjutant General

## DISTRIBUTION:

To be distributed in accordance with DA Form 12-31, AVUM and AVIM Maintenance requirements for UH-1H/V Helicopter, Utility, EH-1H Helicopter, Electronic Countermeasure and EH-1X Helicopter, Electronic Countermeasure & Intercept.

**URGENT**



# URGENT

TM 55-1520-210-23-3  
C 2

CHANGE }  
NO. 2 }

HEADQUARTERS  
DEPARTMENT OF THE ARMY  
WASHINGTON, D.C., 24 August 1989

## Aviation Unit and Intermediate Maintenance Instructions

### ARMY MODEL UH-1H/V/EH-1H/X HELICOPTERS

TM 55-1520-210-23-3, 30 September 1987, is changed as follows:

1. Remove and insert pages as indicated below. New or changed text material is indicated by a vertical bar in the margin. An illustration change is indicated by a miniature pointing hand.

Remove pages	Insert pages
B-3 and B-4	B-3 and B-4
B-17 and B-18	B-17 and B-18
B-22.1/B-22.2	----
B-23 and B-24	B-23 and B-24
B-27 and B-28	B-27 and B-28
----	B-28.1/B-28.2

2. Retain this sheet in front of manual for reference purposes.

By Order of the Secretary of the Army:

CARL E. VUONO  
*General, United States Army*  
Chief of Staff

Official:

WILLIAM J. MEEHAN II  
*Brigadier General, United States Army*  
*The Adjutant General*

#### DISTRIBUTION :

To be distributed in accordance with DA Form 12-31, AVUM and AVIM Maintenance requirements for UH-1H/V Helicopter, Utility, EH-1H Helicopter, Electronic Countermeasure and EH-1X Helicopter, Electronic Countermeasure & Intercept.

# URGENT



# URGENT

TM 55-1520-210-23-3  
C 1

CHANGE }  
NO. 1 }

HEADQUARTERS  
DEPARTMENT OF THE ARMY  
WASHINGTON, D.C., 8 November 1988

## Aviation Unit and Intermediate Maintenance Instructions

### ARMY MODEL UH-1H/V/EH-1H/X HELICOPTERS

TM 55-1520-210-23-3, 30 September 1987, is changed as follows:

1. Remove and insert pages as indicated below. New or changed text material is indicated by a vertical bar in the margin. An illustration change is indicated by a miniature pointing hand.

#### Remove pages

B-3 and B-4  
- - -

B-23 and B-24  
D-1 through D-4  
D-171 and D-172  
D-427

#### Insert pages

B-3 and B-4  
B-22.1/B-22.2  
B-23 and B-24  
D-1 through D-4  
D-171 and D-172  
D-427 and D-428

2. Retain this sheet in front of manual for reference purposes.

By Order of the Secretary of the Army:

CARL E. VUONO,  
*General, United States Army*  
*Chief of Staff*

Official:

WILLIAM J. MEEHAN II  
*Brigadier General, United States Army*  
*The Adjutant General*

#### DISTRIBUTION :

To be distribution in accordance with DA Form 12-31, AVUM and AVIM requirements for UH-1H/V Helicopter, Utility, EH-1H, Helicopter, Electronic Countermeasure and EH-1X Helicopter, Electronic Countermeasure & Intercept.

# URGENT



TECHNICAL MANUAL

No. 55-1520-210-23-3

HEADQUARTERS  
DEPARTMENT OF THE ARMY  
WASHINGTON, D.C., 30 September 1987.

Aviation Unit and Intermediate  
Maintenance Instructions

ARMY MODEL UH-1H/V/EH-1H/X HELICOPTERS

NOTE :

This manual is printed in three volumes as follows:

TM 55-1520-210-23-1, consisting of Table of Contents, preface, Chapters 1 through 6.

TM 55-1520-210-23-2, consisting of Table of Contents, Chapters 7 through 17.

TM 55-1520-210-23-3, consisting of Table of Contents, Appendix A through F, and Index.

The Appendices and Index are applicable to all volumes.





**WARNING**

Personnel performing operations, procedures, and practices which are included or implied in this technical manual shall observe the following warnings. Disregard of these warnings and precautionary information can cause serious injury, or death.

Warnings, cautions, and notes are used to emphasize important and critical instructions and are used for the following conditions:

**WARNING**

An operating procedure, practice, etc., which, if not correctly followed, could result in personal injury or loss of life.

**CAUTION**

An operating procedure, practice, etc., which, if not strictly observed, could result in damage to or destruction of equipment.

## NOTE

An operating procedure, condition, etc., which it is essential to highlight.

## NOISE

Sound pressure levels in this helicopter during some operating conditions exceed the Surgeon General hearing conservation criteria, as defined in TB MED 251. Hearing protection devices, such as aviator helmet or ear plugs are required to be worn by all personnel in and around the helicopter during its operation.

## ELECTROLYTE

Corrosive Battery Electrolyte (Potassium Hydroxide). Wear rubber gloves, apron, and face shield when handling leaking batteries. If potassium hydroxide is spilled on clothing, or other material wash immediately with clean water. If spilled on personnel, immediately start flushing the affected area with clean water. Continue washing until medical assistance arrives.

## TOXIC POISONS

Turbine fuels and lubricating oils contain additives which are poisonous and readily absorbed through the skin. Do not allow them to remain on skin longer than necessary.

## STARTING HELICOPTER

Starting and operation of the helicopter will be performed only by authorized personnel in accordance with AR95-1.

### GROUNDING HELICOPTER

The helicopter should be electrically grounded when parked. Turn off all power switches before making electrical connections or disconnections. Serious burns and electrical shock can result from contact with exposed electrical wires or connectors.

Before removing any engine ignition system component, ground the leads to dissipate any stored voltage in ignition unit.

### FIRE EXTINGUISHER

Exposure to high concentrations of monobromotrifluoromethane (CF3BR) extinguishing agent or decomposition products should be avoided. The liquid should not be allowed to come into contact with the skin, as it may cause frost bite or low temperature burns.

### ARMAMENT

Loaded weapons, or weapons being loaded or unloaded, shall be pointed in a direction which offers the least exposure to personnel or property in the event of accidental firing. Personnel shall remain clear of hazardous area of all loaded weapons.

ANY ROTATION OF THE GUN ARMAMENT SUBSYSTEM BARRELS WILL CAUSE THE GUN TO FIRE. Upon landing, immediately alert personnel to probable presence of live rounds in the gun. Summon armament repairman to clear weapon.

### FUELING AND DEFUELING

When refueling helicopter, the refueling vehicle or forward air refueling unit must be parked a minimum of 20 feet from the helicopter. Before starting the fueling operation, always insert fueling nozzle grounding chain of fuel truck ground wire into GROUND HERE receptacle located on the right side of the helicopter aft of the cabin area. Refer to TM 10-1101.

When defueling, turn off all electrical switches and disconnect external power from the helicopter. The helicopter must be electrically grounded prior to defueling.

### RADIOACTIVE MATERIALS

Self-luminous dials and ignition units may contain radioactive materials. If such an instrument or unit is broken or becomes unsealed, avoid personal contact. Use forceps or gloves made of rubber or polyethylene to pick up contaminated material. Place materials and gloves in a plastic bag. Seal bag and dispose of it as radioactive waste in accordance with AR755-15 and TM 3-261 (Refer to 55- 1500-314-25). Repair procedures shall conform to requirements in AR700-52.

### CLEANING SOLVENTS

Cleaning solvents may be flammable and toxic. Use only in well ventilated areas. Avoid inhalation of vapor and skin contact. Do not use solvents near open flame or in areas where very high temperatures prevail

### ROTOR BLADES

Personnel will stay clear of rotor blades during operation. Refer to Chapter 1 for rotor blade dimensions and clearances.

**AVIATION AND INTERMEDIATE  
MAINTENANCE INSTRUCTIONS  
ARMY MODEL UH-1HNIEH-1HIX HELICOPTER**

**REPORTING OF ERRORS**

You can help improve this manual. If you find any mistakes or if you know of a way to improve the procedures, please let us know. Mail your letter, DA Form 2028 (Recommended Changes to Publications and Blank Forms), or DA Form 20282 located in the back of this manual directly to: Commander, U.S. Army Aviation and Troop Command, ATTN: AMSATIMP, 4300 Goodfellow Blvd., St. Louis, MO 631201798. A reply will be furnished to you. You may also submit your recommended changes by Email directly to <mpmtP/avma28@stlouisemh7.army.mil>. A reply will be furnished to you.

**DISTRIBUTION STATEMENT A:** Approved for public release; distribution is unlimited.

**TABLE OF CONTENTS**

		<b>Page</b>
<b>CHAPTER 1</b>	<b>INTRODUCTION</b>	
Section I	Servicing.....	1-1
	II Lubrication.....	140
	III Handling, Jacking, Mooring, Hoisting, and Sling Loading .....	1-54
	IV Inspection Requirements .....	146
	V Overhaul and Retirement Schedule .....	1-110
	VI Flight Safety Critical Aircraft Parts.....	1-115
<b>CHAPTER 2</b>	<b>AIRFRAME</b>	
Section I	Fuselage.....	2-1
	II Tailboom.....	2-193
<b>CHAPTER 3</b>	<b>ALIGHTING GEAR</b>	
Section I	Landing Gear.....	3-1
	II Skids/Struts .....	3-30
	III Floats.....	3-30
	IV Skis.....	3-30
	V Brakes .....	3-30
<b>CHAPTER 4</b>	<b>POWER PLANT</b>	
Section I	Power Plant.....	4-1
	II Cooling System .....	4-13
	II Air Induction System .....	4-13
	IV Exhaust System .....	4-42.7
	V Oil System .....	4-44
	VI Ignition System.....	4-41
	VII Power Controls.....	4-61
	VIII Quick Change Assembly (AVIM).....	4-86

TABLE OF CONTENTS (Cont)

	Page
<b>CHAPTER 5. ROTORS</b>	
Section I. Main Rotor System . . . . .	5-1
II. Main Rotor Hub . . . . .	5-16
III. Main Rotor Blades . . . . .	5-38.1
IV. Main Rotor Controls . . . . .	5-54.45
V. Tall Rotor System . . . . .	5-105
VI. Tall Rotor Hub and Blade Assembly . . . . .	5-107
VII. Tall Rotor Hub and Controls. . . . .	5-119
VIII. Tall Rotor Blades . . . . .	5-132
IX. Tracking Procedures . . . . .	5-138
<b>CHAPTER 6. DRIVE TRAIN SYSTEM</b>	
Section I. Main Driveshaft . . . . .	6-1
II. Clutch . . . . .	6-29
III. Main Transmission . . . . .	6-29
IV. Tall Rotor Driveshaft . . . . .	6-116.2
V. Intermediate Gearbox . . . . .	6-138
VI. Tall Rotor Gearbox . . . . .	6-147
VII. Oil Systems . . . . .	6-167
<b>CHAPTER 7. HYDRAULIC AND PNEUMATIC SYSTEMS</b>	
Section I. Hydraulic System . . . . .	7-1
II. Pneumatic System (Not Applicable) . . . . .	7-51
<b>CHAPTER 8. INSTRUMENT SYSTEMS</b>	
Section I. Instrument Maintenance . . . . .	8-1
II. Engine instruments . . . . .	8-2
III. Flight Instruments . . . . .	8-22
IV. Navigation Instruments . . . . .	8-33
V. Miscellaneous Instruments . . . . .	8-37
VI. Instrument Panels . . . . .	8-51
<b>CHAPTER 9. ELECTRICAL SYSTEMS</b>	
Section I. Direct Current Power Distribution System . . . . .	9-1
II. Alternating Current Power Distribution System . . . . .	9-41
III. Starting System . . . . .	9-52
IV. Ignition System . . . . .	9-54
V. Lighting Provisions . . . . .	9-56
VI. Miscellaneous Equipment. . . . .	9-94
<b>CHAPTER 10. FUEL SYSTEM</b>	
Section I. Fuel Cells . . . . .	10-1
II. Fuel Systems . . . . .	10-11
<b>CHAPTER 11. FLIGHT CONTROLS</b>	
Section I. Controls Surfaces . . . . .	11-1
II. Flight Control Components . . . . .	11-1

TABLE OF CONTENTS (Cont)

CHAPTER 12	UTILITY SYSTEMS	
Section I	Fire Detector System . . . . .	12-1
II	Windshield Wiper System. . . . .	12-5
III	Rear View Mirror . . . . .	12-20
CHAPTER 13	ENVIRONMENTAL CONTROL SYSTEM	
Section I	Heating System. . . . .	13-1
II	Air Cooling System . . . . .	13-15
III	Winterization Equipment. . . . .	13-18
CHAPTER 14	HOIST AND WINCHES	
Section I	Personnel Rescue Hoist. . . . .	14-1
II	Cargo Suspension Assembly. . . . .	14-76
CHAPTER 15	AUXILLIARY POWER PLANTS	
	(Not Applicable) . . . . .	15-1
CHAPTER 16	MISSION EQUIPMENT. . . . .	16-1
CHAPTER 17	EMERGENCY EQUIPMENT. . . . .	17-1
APPENDIX A	REFERENCE. . . . .	A-1
APPENDIX B	MAINTENANCE ALLOCATION CHART	
Section I	Three Levels of Maintenance Concept. . . . .	B-1
II	Maintenance Allocation Chart . . . . .	B-6
III	Tools and Test Equipment. . . . .	B-76
APPENDIX C	AIRCRAFT INVENTORY MASTER GUIDE . . . . .	C-1
APPENDIX D	ILLUSTRATED FIELD MANUFACTURE ITEMS LIST . . . . .	D-1
APPENDIX E	STORAGE OF AIRCRAFT	
Section I	General Information . . . . .	E-1
II	Flyable Storage. . . . .	E-2
III	Short Term Storage. . . . .	E-3
IV	Intermediate Storage . . . . .	E-10
APPENDIX F	WIRING DIAGRAMS. . . . .	F-1
INDEX	. . . . .	Index 1



## APPENDIX A REFERENCES

---

AR 95-1	Army Aviation General Provisions and Flight Regulations
AR 95-3	Weight and Balance Army Aircraft
AR 310-50	Authorized Abbreviations and Brevity Codes
DA Form 2028	Recommended Changes to Publications and Blank Forms
DA Form 2408-13	Aircraft Inspection and Maintenance Record
DA Form 2410	Component Removal and Repair/Overhaul Record
DA PAM 501	Hearing Conservation
DA PAM 738-750	Functional Users Manual for the Army Maintenance Management Systems
DA PAM 738-751	Functional Users Manual for the Army Maintenance Management Systems-Aviation (TAMMS-A)
FM 3-5	NBC Decontamination
FM 10-68	Aircraft Refueling
FM 10-69	Petroleum Supply Point Equipment and Operation
MIL-STD-12C	Abbreviations for Use on Drawings, Specifications, Standards and in Technical Documents
TB 1 -1500-341-01	Aircraft Components Requiring Maintenance Management and Historical Data Reports
TB 1-1615-351-23	Rotor Blade Erosion Protection
TB 43-0002-3	Maintenance Expenditure Limitations for Army Aircraft
TB 43-0106	Aeronautical Equipment Army Oil Analysis Program (AOAP)
TB 43-180	Calibration Requirements for the Maintenance of Army Materiel
TB 55-1500-314-24	Handling, Storage, and Disposal of Army Aircraft Components Containing Radioactive Materials
TB 55-1500-334-25	Conversion to Fire Resistant Hydraulic Fluid
TB 55-1500-337-24	Phased Maintenance System for Army Aircraft
TB 55-9150-200-24	Engine and Transmission Oils, Fuels, and Additives for Army Aircraft
TB 750-25	Maintenance of Supplies and Equipment Army Metrology and Calibration System
TM 1-1500-204-23-1 thru 10	General Aircraft Maintenance Manual
TM 1-1500-328-23	Aeronautical Equipment Maintenance Management Policies and Procedures
TM 1-1500-344-23	Aircraft Weapons Systems Cleaning and Corrosion Control
TM 1-1520-250-23	General Tie-Down and Mooring

**TM 55-1520-210-23-3**

- TM 9-1005-224-24 Organizational, DS, and GS Maintenance Manual for Machine Gun, 7.62MM Machine Gun
- TM 9-1345-201-12 Mine Dispersing Subsystem. Aircraft M56
- TM 91345-201-30&P Direct Support Maintenance Manual (including Repair Parts and Special Tools List): Mine Dispersing Subsystem, Aircraft M56 (NSN 1345-00-313-1398)
- TM 11-1520-210-E&C Equipment Serviceability Criteria for Electronic Equipment Configuration in Army Models UH-1BIC/D Helicopters
- TM 11-1520-210-23 Organizational Maintenance Manual: Electronic Equipment Configuration in Army UH-1D/H Helicopter (NSN 1520-00-859-0670) UH-1H (1520-00-087-7673) and UH-1V (1520-01-043-4949) Helicopters
- TM 11-1520-210-34P Direct Support and General Maintenance Repair Parts and Special Tools List (including Depot Maintenance Repair Parts and Special Tools): Electronic Equipment Configuration. Army Models UH-1D and UH-1H Helicopters
- TM 11-5821-333-12 Unit and Intermediate Maintenance Manual for Sincgars Airborne Combat Network Radio
- TM 11-5821-333-30 Aviation Intermediate Maintenance Manual for Sincgars Airborne Combat Network Radio
- TM 11-5841-272-20 Organizational Maintenance Manual. Altimeter Set Electronic, AN/AP-N-171A(V)1
- TM 11-5895-776-13-1 Operator, Organizational, Direct Support and General Support Manual, Counter measures System, Radio AN/ARQ-33
- TM 11-6125-220-20 Operational Maintenance Manual: Motor-Generators PU-543/A, PU-543A/A, PU-543B/A, and PU-543C/A (MS-21983)
- TM 11-6140-203-14-2 Operators Organizational, Direct Support, General Support and Depot Maintenance Manual Including Repair Parts and Special Tools Lists: Aircraft Nickel-Cadmium Batteries
- TM 55-1500-335-23 Nondestructive Inspection Method
- TM 55-1500-342-23 Army Aviation Maintenance Engineering Manual: Weight and Balance
- TM 55-1500-345-23 Painting and Marking of Army Aircraft
- TM 55-1520-210-PM UH-I HN Aircraft Phased Maintenance Checklist
- TM 55-1520-210-PMD UH-1HN Aircraft Preventive Maintenance Daily Inspection Checklist
- TM 55-1520-210-10 Operator's Manual: Army Model UH-1H/V Helicopter
- TM 55-1520-210-23P Aviation Unit and Intermediate Maintenance Repair Parts and Special Tools List (Including Depot Maintenance Repair Parts and Special Tools)
- TM 55-1520-242-MTF Aircraft Maintenance Test Flight Manual for UH-1 and EH-1 Helicopters
- TM 55-1520-242-S Preparation for Shipment of UH-1 Helicopters
- TM 55-1680-320-23&P High Performance Rescue Hoist
- TM 55-2620-200-24 Inspection. Maintenance Instructions. Storage. and Disposition of Aircraft Tires and Inner Tubes
- TM 55-2840-229-23P Aviation Unit and Intermediate Maintenance Repair Parts and Special Tools List



TM 55-4920-201-14 Operator's Organizational. DS and GS Maintenance Manual Including Repair Parts and Special Tool List Balancing and Adapter Kits (Marvel)

TM 55-4920-244-14 Operator's Organizational. Direct Support and General Support Maintenance Manual

TM 750-244-1-5 Procedures for Destruction of Aircraft and Associated Equipment to Prevent Enemy Use

**Change 8 A-3/(A-4 blank)**



## APPENDIX B

### MAINTENANCE ALLOCATION CHART

#### SECTION I. THREE LEVELS OF MAINTENANCE CONCEPT

##### INTRODUCTION

#### B-1. MAINTENANCE ALLOCATION CHART.

a. This Maintenance Allocation Chart (MAC) assigns maintenance functions in accordance with the Three Levels of Maintenance concept for army aircraft. These maintenance levels, Aviation Unit Maintenance (AVUM); Aviation Intermediate Maintenance (AVIM) and Depot Maintenance are depicted on the MAC as:

AVUM which corresponds to the O Code in the RPSTL.

AVIM which corresponds to an F Code in the RPSTL.

DEPOT which corresponds to a D Code in the RPSTL

b. The maintenance to be performed below depot and in the field as described as follows:

(1) Aviation Unit Maintenance (AVUM) activities will be staffed and equipped to perform high frequency "On-Aircraft" maintenance tasks required to retain or return aircraft to a serviceable condition. The maintenance capability of the AVUM will be governed by the Maintenance Allocation Chart (MAC) and limited by the amount and complexity of ground support equipment (GSE), facilities required, and number of spaces and critical skills available. The range and quantity of authorized spare modules/components will be consistent with the mobility requirements dictated by the air mobility concept. (Assignments of maintenance tasks to divisional company size aviation units will consider the overall maintenance capability of the division, the requirement to

conserve personnel and equipment resources and air mobility requirements.)

(a) Company Size Aviation Units: Perform those tasks which consist primarily of preventive maintenance and maintenance repair and replacement functions associated with sustaining a high level of aircraft operational readiness. Perform maintenance inspections and servicing to include preflight, daily, intermediate, periodic and special inspections as authorized by the MAC or higher headquarters. Identify the cause of equipment/system malfunctions using applicable technical manual troubleshooting instructions, built-in-test equipment (BITE), installed aircraft instruments, or easy to use/interpret diagnostic/fault isolation devices (TMDE). Replace worn or damaged modules/components which do not require complex adjustments or system alignment and which can be removed/installed with available skills, tools and equipment. Perform operational and continuity checks and make minor repairs to the electrical system. Inspect, service and make operational, capacity and pressure checks to hydraulic systems. Perform servicing, functional adjustments, and minor repair/replacement to the flight control, propulsion, power train and fuel systems. Accomplish air frame repair which does not require extensive disassembly, jiggling, or alignment. The manufacture of air frame parts will be limited to those items which can be fabricated with tools and equipment found in current air mobile tool and shop sets. Evacuate unserviceable modules/components and end items beyond the repair capability of AVUM to the supporting AVIM.

(b) Less than Company Size Aviation Units: Aviation elements organic to brigade, group, battalion headquarters and detachment size units

are normally small and have less than ten aircraft assigned. Maintenance tasks performed by these units will be those which can be accomplished by the aircraft crew chief or assigned aircraft repairman and will normally be limited to preventive maintenance, inspections, servicing, spot painting, stop drilling, application of nonstress patches, minor adjustments, module/component fault diagnosis and replacement of selected modules/components. Repair functions will normally be accomplished by the supporting AVIM unit.

(2) Aviation Intermediate Maintenance (AVIM) provides mobile, responsive "One Stop" maintenance support. (Maintenance functions which are not conducive to sustaining air mobility will be assigned to depot maintenance). Performs all maintenance functions authorized to be done at AVUM. Repair of equipment for return to user will emphasize support or operational readiness requirements. Authorized maintenance includes replacement and repair of modules/components and end items which can be accomplished efficiently with available skills, tools, and equipment. Established the Direct Exchange (DX) program for AVUM units by repairing selected items for return to stock when such repairs cannot be accomplished at the AVUM level. Inspects, troubleshoots, tests, diagnoses, repairs, adjusts, calibrates, and aligns aircraft system modules/components. AVIM units will have the capability to determine the serviceability of specified modules/components removed prior to the expiration of the Time Between Overhaul (TBO) or finite life. Module/component disassembly and repair will support the DX program and will normally be limited to tasks requiring cleaning and the replacement of seals, fittings and items of common hardware. Air frame repair and fabrication of parts will be limited to those maintenance tasks which can be performed with available tools and test equipment. Unserviceable repairable modules/components and end items which are beyond the capability of AVIM to repair will be evacuated to Depot Maintenance. This level will perform aircraft weight and balance inspections and other special inspections which exceed AVUM capability. Provides quick response maintenance support, including aircraft recovery and air evacuation, on-the-job training, and technical assistance through the use of mobile maintenance contact teams. Maintains authorized operational readiness float aircraft. Provides

collection and classification services for serviceable/unserviceable material. Operates a cannibalization activity in accordance with AR 750-50. (The aircraft maintenance company within the maintenance battalion of a division will perform AVIM functions consistent with air mobility requirements and conservation of personnel and equipment resources. Additional intermediate maintenance support will be provided by the supporting nondivisional AVIM unit.)

## **B-2. USE OF THE MAINTENANCE ALLOCATION CHART.**

a. The Maintenance Allocation chart assigns maintenance functions to the lowest level of maintenance based on past experience and the following consideration:

(1) Skills available.

(2) Time required.

(3) Tools and test equipment required and/or available.

b. Only the lowest level of maintenance authorized to perform a maintenance function is indicated.

c. A maintenance function assigned to a maintenance level will automatically be authorized to be performed at any higher maintenance level.

d. A maintenance function that cannot be performed at the assigned level of maintenance for any reason may be evacuated to the next higher maintenance organization. Higher maintenance levels will perform the maintenance functions of lower maintenance levels when required or directed by the appropriate commander.

e. The assignment of a maintenance function will not be construed as authority to carry the associated repair parts in stock. Authority to requisition, stock, or otherwise secure necessary repair parts will be as specified in the repair parts appendix.

f. Normally there will be no divation from the assigned level of maintenance. In cases of operational necessity, maintenance functions assigned to a higher maintenance level may, at the request of the lower maintenance level, be

specifically authorized by the maintenance officer of the level of maintenance to which the function is assigned. The special tools, equipment, etc. required by the lower level of maintenance to perform this function will be furnished by the maintenance level to which the function is assigned. This transfer of a maintenance function to a lower maintenance level does not relieve the higher maintenance level of the responsibility of the function. The higher level of maintenance has the authority to determine:

(1) If the lower level is capable of performing the work.

(2) If the lower level will require assistance or technical supervision and on-site inspection.

(3) If the authorization will be granted to perform maintenance.

**g. Organizational** through depot maintenance of the U.S. Army Electronics Command equipment will be performed by designated U.S. Army Electronics Command personnel.

**h. Changes** to the Maintenance Allocation Chart will be based on continuing evaluation and analysis by responsible technical personnel and on reports received from field activities.

### B-3. DEFINITIONS.

Maintenance functions. Maintenance functions will be limited to and defined as follows:

**a. Inspect.** To determine the serviceability of an item by comparing its physical, mechanical and/or electrical characteristics with established standards through examination.

**b. Test.** To verify serviceability and detect incipient failure by measuring the mechanical or electrical characteristics of an item and comparing those characteristics with prescribed standards.

**c. Service.** Operations required periodically to keep an item in proper operating condition, i.e. to clean (decontaminate), to preserve, to drain, to paint, or to replenish fuel, lubricants, hydraulic fluids, or compressed air supplies.

**d. Adjust.** To maintain, within prescribed limits, by bringing into proper or exact position, or by setting the operating characteristics to specified parameters.

**e. Align.** To adjust specified variable elements of an item to bring about optimum or desired performance.

**f. Calibrate.** To determine and cause corrections to be made or to be adjusted on instruments or test measuring and diagnostic equipments used in precision measurement. Consists of comparisons of two instruments, one of which is a certified standard of known accuracy, to detect and adjust any discrepancy in the accuracy of the instrument being compared.

**g. Install.** The act of emplacing, seating, or fixing into position an item, part, or module (component or assembly) in a manner to allow the proper functioning of an equipment or system.

**h. Replace.** The act of substituting a serviceable like type part, subassembly, or module (component or assembly) for an unserviceable counterpart.

**i. Repair.** The application of maintenance services or other maintenance action to restore serviceability to an item by correcting specific damage, fault, malfunction, or failure in a part, subassembly, module (component or assembly), end item, or system.

**j. Overhaul.** That maintenance effort (service/action) necessary to restore an item to a completely serviceable/operational condition as prescribed by maintenance standards (i.e. DMWR) in appropriate technical publications. Overhaul is normally the highest degree of maintenance performed by the Army. Overhaul does not normally return an item to like new condition.

**k. Rebuild.** Consists of those services/actions necessary for the restoration of unserviceable equipment to a like new condition in accordance with original manufacturing standards. Rebuild is the highest degree of materiel maintenance applied to Army equipment. The rebuild operation includes the act of returning to zero those age measurements (hours/miles, etc.) considered in classifying Army equipments/components.

**B-4. STANDARD GROUPS.**

The standard groupings shown below are used, as applicable, throughout this MAC Maintenance manuals and RPSTLs reflect these standard

groupings as individual chapters with sections in each chapter relative to the individual complete systems, subsystems, modules, components, assemblies, or specific parts noted.

**AIRFRAME ITEMS**

GROUP NUMBER DESCRIPTION	GROUP NUMBER DESCRIPTION
00 Aircraft System	06 Drive Train Systems
01 Aircraft General  Servicing, handling, inspection requirements, lubrication requirements, overhaul and retirement requirements, cleaning, mooring, towing, jacking, hoisting, preservation requirements, weight and balance requirements, spot painting, complete painting, and subassembly painting requirements.	07 Hydraulic and Pneumatic Systems  Pumps, filters, reservoirs, cylinders, valves, servos, motors, starters and accumulators.
02 Airframe  Fuselage, empennage, pylons, wings, mounts (engine and transmission), armor, seats, ramps, decks, and tiedowns.	08 Instrument Systems  Flight instruments, navigation instruments, engine instruments, miscellaneous instruments (i. e., clocks), sending units, panels, and flow meters.
03 Alighting Gear  Landing gear, skids, floats, skis, struts, wheel brakes, and mechanical mechanisms.	09 Electrical Systems  Motors, actuators, regulators, generators, starters, batteries, lighting, caution and warning lights, inverters, fault isolation systems, rotor brakes, and avionics provisions.
04 Power Plant Installation  Removal, installation, cooling systems, air induction, exhaust, oil systems, components, ignition systems, power control, harnesses, carburetors, fuel controls, pumps (engine driven), filters/particle separators, and Quick Change Assemblies (QCA). (See Power Plant Items, figure 2, for more detailed functions.)	10 Fuel Systems  Tanks, cells, filters, pumps, valves, auxiliary fuel systems, and refueling systems.
05 Propellers/Rotors Systems Propellers, governors, rotors (main and tail), hubs, blades, dampeners, stabilizer bars, swashplates, hub moment springs, and support assemblies.	11 Flight Controls System  Control sticks, pedals, cables, pulleys, push-pull rods, torque tubes, quadrants, force gradients, control surfaces, bellcranks, and trim actuators (mechanical).

GROUP NUMBER	DESCRIPTION	GROUP NUMBER	DESCRIPTION
12	Utility System.  Fire detecting/extinguishing systems, oxygen systems, windshield wiper systems, mirrors, and de-ice/anti-ice systems.	16	Mission Equipment  Spraying equipment, stores, racks, armament, reconnaissance, photography, pods, and litters.
13	Environmental Control Systems (ECS)  Heaters, air conditioners, defrosters, control mixing valves, and ducts.	17	Emergency Equipment  Ejection seats, canopies, jettison system, portable fire extinguishers, axes, and first aid kits.
14	Hoists and Winches  Cargo/rescue hoists, winches, hooks, slings, loading systems, and emergency release systems.	18	Installed Avionics Components  Communications and Navigational Black Boxes.
15	Auxiliary Power Plants (APP)  Fuel, exhaust, and ducting.		

**B-5. SYMBOLS.**

The letters "AVUM, AVIM AND DEPOT" as placed on the Maintenance Allocation Chart indicate the level of Maintenance responsible for performing the particular maintenance function based upon assigned skills, tools and test equipment and time required to accomplish maintenance.

**B-6. WORK TIMES.**

The symbol -o- identifies the level of Maintenance authorized to perform a maintenance function and indicates that work time figures are being developed and will be entered at a later date. When developed, this time will appear: for example, as 0.1 and also indicates the level of authorized maintenance.

**B-7. TOOLS AND TEST EQUIPMENT/ (SECTION III).**

Special tools, test, and support equipment required to do maintenance functions are listed with a reference number to permit cross-referencing to column 5 in the MAC. In addition, the maintenance category authorized to use the device is listed along with the item National Stock Number and if applicable, the number to aid in identifying the tool/device.

**B-8. REMARKS (SECTION IV).**

Column 6 of the MAC contains alphabetic reference codes which are explained in Section IV of this appendix.

SECTION II. MAINTENANCE ALLOCATION CHART

MAINTENANCE ALLOCATION CHART							
NOMENCLATURE OF END ITEMS							
HELICOPTER UTILITY - TACTICAL TRANSPORT UH-1H/UH-1V/EH-1H							
(1)	(2)	(3)	(4)			(5)	(6)
GROUP NUMBER	COMPONENT/ASSEMBLY	MAINTENANCE FUNCTION	MAINTENANCE CATEGORY			TOOLS AND EQUIPMENT	REMARKS
			AVUM	AVIM	DEPOT		
NOTE							
The extent of maintenance to be performed by AVUM as indicated in this MAC is governed by the size of the Unit and the Tools authorized (Refer to paragraph B-1 b(1) a. and b.). Specific notes are given to further Identify or describe the extent or limit of maintenance to be performed.							
0100	Aircraft General						
0101	Clean		— ● —				
0102	Moor		— ● —				
0103	Tow		— ● —			100	
0104,	Jack		— ● —			100,102	
0105	Hoist		— ● —				
0106	Preservation		— ● —			100,102	
0107	Weight & Balance			— ● —		102,118 121	
0108	Spot Paint		— ● —			100	
0109	Complete Painting				— ● —		
0110	Sub-Assembly Painting			— ● —		118	
0110	Servicing		— ● —			100,102	
0200	Airframe	Inspect	— ● —				
		Repair	— ● —			100,102 103	A
				— ● —		117,120, 118	
		Overhaul			— ● —		



<b>MAINTENANCE ALLOCATION CHART</b> (AVSCOM Reg:310.10)							
NOMENCLATURE OF END ITEMS HELICOPTER, UTILITY - TACTICAL, TRANSPORT UH-1H/UH-1V/EH-1H							
(1) GROUP NUMBER	(2) COMPONENT ASSEMBLY	(3) MAINTENANCE FUNCTION	(4) MAINTENANCE CATEGORY			(5) TOOLS AND EQUIPMENT	(6) REMARKS
			AVUM	AVIM	DEPOT		
0201	Tail Boom Assy	Inspect	— ● —				
		Replace	— ● —			100, 102	B
		Repair	— ● —			100, 102 103	A
		Overhaul		— ● —	— ● —	102, 117	
0202	Fuselage	Inspect	— ● —				
		Repair	— ● —			100, 102 103 102, 117	A
0202 01	Sheet Metal for Structural Members and Honeycomb Panels not requiring Jigs and Fixtures	Inspect	— ● —				
		Replace	— ● —			100, 102 103	A
		Repair	— ● —			100, 102 103 102, 117	A
0202 02	Sheet Metal for Structural Members and Honeycomb Panels that require Jigs & Fixtures	Inspect	— ● —				
		Replace			— ● —		
		Repair	— ● —	— ● —	— ● —		
0202 03	Honeycomb Panels	Inspect	— ● —				
		Replace	— ● —			100, 102	
		Repair	— ● —			100, 102 103 102, 117	A

MAINTENANCE ALLOCATION CHART (AVSCOM Reg 310-10)							
NOMENCLATURE OF END ITEMS HELICOPTER, UTILITY - TACTICAL TRANSPORT UH-1H/UH-1V/EH-1H							
(1) GROUP NUMBER	(2) COMPONENT/ASSEMBLY	(3) MAINTENANCE FUNCTION	(4) MAINTENANCE CATEGORY			(5) TOOLS AND EQUIPMENT	(6) REMARKS
			AVUM	AVIM	DEPOT		
0202 04	Cabin Nose Assembly						
0202 04 01	Lower Windows	Inspect	— ● —				
		Replace	— ● —			100,102	
		Repair	— ● —			100, 102	D
0202 04 02	Windshield	Inspect	— ● —				
		Replace	— ● —			100, 102	
		Repair	— ● —			100, 102	D
0202 04 03	Ejection Handles	Inspect	— ● —				
		Replace	— ● —			100, 102	
		Repair	— ● —			100, 102	
<b>0202</b> 05	Doors, Crew	Inspect	— ● —				
		Adjust	— ● —			100, 102	
		Replace	— ● —			100, 102	
		Repair	— ● —			100, 102 103	

MAINTENANCE ALLOCATION CHART (AVSCOM Reg 310-10)							
NOMENCLATURE OF END ITEMS HELICOPTER, UTILITY - TACTICAL TRANSPORT UH-1H/UH-1V/EH-1H							
(1) GROUP NUMBER	(2) COMPONENT/ASSEMBLY	(3) MAINTENANCE FUNCTION	(4) MAINTENANCE CATEGORY			(5) TOOLS AND EQUIPMENT	(6) REMARKS
			AVUM	AVIM	DEPOT		
0202 05 01	Window Assembly	Inspect	- ● -				
		Replace	- ● _			100 102	
		Repair	- + -			100 102	D
0202 05 02	Striker Assembly	Inspect	- ● -				
		Replace	- ● _			100 102	
		Repair	- ● _			100 102 103	
0202 05 03	Handle Assembly	Inspect	- ● -				
		Replace	- ● _			100 102	
		Repair	- ● -			100 102 103	
0202 06	Cabin Roof Assembly						
0202 06 01	Windows	Inspect	- ● _				
		Replace	- ●			100, 102	
		Repair	- ● -			100, 102	D
0202 06 02	Air Vent Pans	Inspect	- ●				
		Replace	- ● -			100, 102	
		Repair	- ● -			100, 102	

**MAINTENANCE ALLOCATION CHART**  
(AVSCOM Reg 310-10)

NOMENCLATURE OF END ITEMS  
HELICOPTER, UTILITY — TACTICAL TRANSPORT UH-1H/UH-1V/EH-1H

(1) GROUP NUMBER	(2) COMPONENT/ASSEMBLY	(3) MAINTENANCE FUNCTION	(4) MAINTENANCE CATEGORY			(5) TOOLS AND EQUIPMENT	(6) REMARKS
			AVUM	AVIM	DEPOT		
0202 07	Panel Assembly, Hinged	Inspect	— • —				
		Replace	— • —			100, 102	
		Repair	— • —			100, 102 103, 102, 117	A
0202 07 01	Window Assembly	Inspect	— • —	— • —			
		Replace	— • —			100, 102	
		Repair	— • —			100, 102	D
0202 07 02	Latches	Inspect	— • —				
		Replace	— • —			100, 102	
		Repair	— • —			100, 102 103	
0202 08	Seat Installation Pilots and Co-pilots	Inspect	— • —				
		Repair	— • —			100, 102	
0202 08 01	Seat Belts and Shoulder Harness	Inspect	— • —				
		Replace	— • —			100, 102	
0202 08 02	Shoulder Harness Reel	Inspect	— • —				
		Replace	— • —			100, 102	
0202 08 03	Seat Assembly	Inspect	— • —				
		Replace	— • —			100, 102	
		Repair	— • —			100, 102 103	

**MAINTENANCE ALLOCATION CHART**  
(AVSCOM Reg 310-10)

NOMENCLATURE OF END ITEMS

HELICOPTER, UTILITY - TACTICAL TRANSPORT UH-1H\UH-1V\EH-1H

(1) GROUP NUMBER	(2) COMPONENT ASSEMBLY	(3) MAINTENANCE FUNCTION	(4) MAINTENANCE CATEGORY			(5) TOOLS AND EQUIPMENT	(6) REMARKS
			AVUM	AVIM	DEPOT		
0202 08 03 01	Armor	Inspect	— ● —				
		Replace	— ● —			100, 102	
		Repair	— ● —			100, 102, 103	
0202 08 03 02	Carriage Assy	Inspect	— ● —			100 ,102	
		Replace	— ● —			100,102, 103	
		Repair	— ● —	— ● —		102, 117 120	<b>A</b>
0202 09	Seat Installation, Passenger	Inspect	— ● —				
		Repair	— ● —			100, 102	
0202 09 01	Seat	Inspect	— ● —				
		Replace	— ● —			100,102	
		Repair	— ● —			100,102	AG
0202 09 02	Seat Belts	Inspect	— ● —				
		Replace	— ● —			100 ,102	



MAINTENANCE ALLOCATION CHART (AVSCOM Reg 310-10)							
NOMENCLATURE OF END ITEMS HELICOPTER, UTILITY - TACTICAL TRANSPORT UH-1H/UH-1V/EH-1H							
(1) GROUP NUMBER	(2) COMPONENT/ASSEMBLY	(3) MAINTENANCE FUNCTION	(4) MAINTENANCE CATEGORY			(5) TOOLS AND EQUIPMENT	(6) REMARKS
			AVUM	AVIM	DEPOT		
0202 10	SEAT, CREW	Inspect	- ● -				EH-1H Only
		Service	- ● -			100, 102	
		Adjust	- ● -			100, 102	
		Replace	- ● -			100, 102	
		Repair	- ● -			100, 102	
0202 11	Blanket Assembly, Soundproofing	Inspect	- ● -	- ● -		102,117 120	
		Replace	- ● -			100,102	
		Repair	- ● -			100,102	
					- ● -		102,117

**MAINTENANCE ALLOCATION CHART**  
(AVSCOM Reg 310-10)

NOMENCLATURE OF END ITEMS

HELICOPTER, UTILITY - TACTICAL TRANSPORT UH-1H/\UH-1V/EH-1H

(1) GROUP NUMBER	(2) COMPONENT/ASSEMBLY	(3) MAINTENANCE FUNCTION	(4) MAINTENANCE CATEGORY			(5) TOOLS AND EQUIPMENT	(6) REMARKS
			AVUM	AVIM	DEPOT		
0202 12 01	Window	Inspect	- ● -				
		Replace	- ● -			100,102	
		Repair	- ● -			100,102	D
0202 12 02	Latch	Inspect	- ● -				
		Repair	- ● -			100,102	
0202 13	Door Assembly, Equipment	Inspect	- ● -				
		Replace	- ● -			100,102	
		Repair	- ● -			100, 102 103	
0202 14	Inspection Doors	Inspect	- ● -				
		Replace	- ● -			100,102	
		Repair	- ● -			100, 102 103	
0202 15	Deck Assembly, Left and Right Engine	Inspect	- ● -				
		Align		- ● -			
		Replace		- ● -		100,102	
		Repair	- ● -			100, 102 103	A
				- ● -		102, 117	



MAINTENANCE ALLOCATION CHART (AVSCOM Reg 310-10)							
NOMENCLATURE OF END ITEMS HELICOPTER, UTILITY - TACTICAL TRANSPORT UH-1H/UH-1V/EH-1H							
(1) GROUP NUMBER	(2) COMPONENT/ASSEMBLY	(3) MAINTENANCE FUNCTION	(4) MAINTENANCE CATEGORY			(5) TOOLS AND EQUIPMENT	(6) REMARKS
			AVUM	AVIM	DEPOT		
0202 16	Deck Assembly, Center Engine	Inspect	— ● —				
		Align		— ● —		100,T89 T90,102	E
		Replace		— ● —		100,102 103,T89 T90	E
		Repair	— ● —			100,102 103	A
0202 17	Mount Assembly	Inspect	— ● —				
		Align	— ● —			100,102	
		Replace	— ● —			102,100	
		Repair	— ● —			102,100 1 0 3	A
0202 18	Cowl Assemblies	Inspect	— ● —				
		Replace	— ● —			102,100	
		Repair	— ● —			102,103 100	
		Inspect		— ● —		102,117	AH
0202 19	Baffle Assembly	Inspect	— ● —				
		Replace	— ● —			103,100 102	
		Repair	— ● —			103,100 102	
				— ● —		102,117	

**MAINTENANCE ALLOCATION CHART**  
(AVSCOM Reg 310-10)

NOMENCLATURE OF END ITEMS

HELICOPTER, UTILITY - TACTICAL TRANSPORT UH-1H/UH-1V/EH-1H

(1) GROUP NUMBER	(2) COMPONENT/ASSEMBLY	(3) MAINTENANCE FUNCTION	(4) MAINTENANCE CATEGORY			(5) TOOLS AND EQUIPMENT	(6) REMARKS
			AVUM	AVIM	DEPOT		
0202 20	Firewall Assembly	Inspect	- ● -				
		Replace	- ● -			103,100 102	
		Repair	- ● -			103,100 102	
0202 21	Heatshield Assy	Inspect	- ● -	- ● -		102,117	
		Replace	- ● -			103,100 102	
		Repair	- ● -			103,100 102	
0202 22	Mount Installation, Engine			- ● -		102,117	
0202 22 01	Support Arms (Brace Rods, Tripod, and (Bi-Pod)	Inspect	- ● -				
		Replace	- ● -			102,T10 100	
		Repair	- ● -			102,100	F
				- ● -		102,120	AH
0202 22 02	Pillow Block Assy	Inspect	- ● -				
		Replace	- ● -			102,T10 100	
		Repair	- ● -			102,100	
0202 23	Map and Data Case	Inspect	- ● -				
		Replace	- ● -			102,100	
		Repair	- ● -			100,102	AG

<b>MAINTENANCE ALLOCATION CHART</b> (AVSCOM Reg 310-10)							
NOMENCLATURE OF END ITEMS HELICOPTER, UTILITY - TACTICAL TRANSPORT UH-1H/UH-1V/EH-1H							
(1) GROUP NUMBER	(2) COMPONENT ASSEMBLY	(3) MAINTENANCE FUNCTION	(4) MAINTENANCE CATEGORY			(5) TOOLS AND EQUIPMENT	(6) REMARKS
			AVUM	AVIM	DEPOT		
0300	Alighting Gear Assembly						
0301	Cross Tubes	Inspect	— ● —			100,102	
		Replace	— ● —			102,100	
		Repair	— ● —			103,100 102	A
0302	Skid Tubes	Inspect	— ● —				
		Replace	— ● —			102,100	
		Repair	— ● —			100,102 103	A
0303	Skid Shoes	Inspect	— ● —				
		Replace	— ● —			102,100	
		Repair	— ● —			100,102 103 102,117 120	A AH
0304	Skid Saddles	Inspect	— ● —				
		Replace	— ● —			100,102	
0305	Truck (Ground Handling Wheels)	Inspect	— ● —				
		Replace	— ● —			100,102	
		Repair	— ● —			100,102 103	

MAINTENANCE ALLOCATION CHART (AVSCOM Reg 310-10)							
NOMENCLATURE OF END ITEMS HELICOPTER UTILITY - TACTICAL TRANSPORT UH-1H/UH-1V/EH-1H							
(1) GROUP NUMBER	(2) COMPONENT ASSEMBLY	(3) MAINTENANCE FUNCTION	(4) MAINTENANCE CATEGORY			(5) TOOLS AND EQUIPMENT	(6) REMARKS
			AVUM	AVIM	DEPOT		
0305 01	Pump Assembly	Inspect	— ● —				
		Test	— ● —				
		Replace	— ● —			102,100	
		Repair				111,102	
0305 02	Cylinder Assembly	Inspect	— ● —				
		Replace	— ● —			102,100	
		Repair				111,102	
0305 03	Wheel Assembly	Inspect	— ● —				
		Replace	— ● —			102,100	
		Repair	— ● —			100,102	
0306	Skid Installation, Tail	Inspect	— ● —				
		Replace	— ● —			102,100	
		Repair	— ● —			102,100 103	
0307	Ski Isolation Damper	Inspect	— ● —				
		Install	— ● —			100,102	
		Replace	— ● —			100,102	
		Repair	— ● —			100,102	



MAINTENANCE ALLOCATION CHART

NOMENCLATURE OF END ITEMS

HELICOPTER UTILITY - TACTICAL TRANSPORT UH-1H/UH-1V/EH-1H

(1) GROUP NUMBER	(2) COMPONENT/ASSEMBLY	(3) MAINTENANCE FUNCTION	(4) MAINTENANCE CATEGORY			(5) TOOLS AND EQUIPMENT	(6) REMARKS
			AVUM	AVIM	DEPOT		
0404	Heat Suppressor	Inspect	— ● —				
		Replace	— ● —			102,100	
		Repair	— ● —			100,103 102	<b>A</b>
0405	Actuator, Linear	Inspect	— ● —	— ● —		102,117	
		Adjust	— ● —			102,100	
		Replace	— ● —			100,102	
		Repair	— ● —			102,100	
		Repair		— ● —			<b>AN</b>
0406	Controls, Power Lever	Inspect	— ● —				
		Adjust	— ● —			102,100	
		Replace	— ● —			102,100	
		Repair	— ● —			102,100	
0407	Droop Compensator	Inspect	— ● —				
		Adjust	— ● —			102,100	
		Replace	— ● —			102,100	
		Repair	— ● —			102,100	
0408	Oil Tank, Engine	Inspect	— ● —				
		Test	— ● —			102,100	
		Service	— ● —			102,100	
		Replace	— ● —			102,100	
		Repair	— ● —		— ● —	102,100	
					102,120	<b>AH</b>	

**MAINTENANCE ALLOCATION CHART**

(AVSCOM Reg 310-10)

NOMENCLATURE OF END ITEMS

HELICOPTER, UTILITY - TACTICAL TRANSPORT UH-1H/UH-1V/EH-1 H

(1) GROUP NUMBER	(2) COMPONENT/ASSEMBLY	(3) MAINTENANCE FUNCTION	(4) MAINTENANCE CATEGORY			(5) TOOLS AND EQUIPMENT	(6) REMARKS
			AVUM	AVIM	DEPOT		
0409	Hoses, Fittings, and Tubing	Inspect	-- • --				
		Replace	-- • --			102,100	
0410	Oil Cooler, Engine	Inspect	-- • --				
		Test		-- • --			
		Replace	-- • --			102,100	
		Repair	-- • --			102,100	M
0411	Blower, Turbine	Inspect	-- • --				
		Replace	-- • --			102,100	
		Repair	-- • --			119,102 112,118 120	AH
0412	Chip Detector, Engine	Inspect	-- • --				
		Test	-- • --			102,100	
		Replace	-- • --			102,100	
0413	Filter Assembly, Inlet	Inspect	-- • --				
		Replace	-- • --			102,100	
		Repair	-- • --			102,100	
0414	Valves, Breakaway	Inspect	-- • --				
		Replace	-- • --			100,102	
0415	External Filter	Inspect	-- • --				
		Replace	-- • --			100,102, 107	
		Repair	-- • --				
0416	Oil Separator (Lubriclone)	Inspect	-- • --				
		Replace	-- • --			100,102, 107	
		Repair	-- • --				

**MAINTENANCE ALLOCATION CHART**

(AVSCOM Reg 310-10)

NOMENCLATURE OF END ITEMS

HELICOPTER, UTILITY - TACTICAL TRANSPORT UH-1H/UH-1V/EH-1H

(1) GROUP NUMBER	(2) COMPONENT/ASSEMBLY	(3) MAINTENANCE FUNCTION	(4) MAINTENANCE CATEGORY			(5) TOOLS AND EQUIPMENT	(6) REMARKS
			AVUM	AVIM	DEPOT		
0500	Rotor Systems						
0501	Pylon Assembly, External Components	Inspect	— • —				
		Replace	— • —			102,100	
		Repair	— • —			100,102 103	A
0502	Stabilizer Bar Assy	Inspect	— • —				
		Adjust		— • —		102,113 T99A	K
		Replace	— • —			102,100	
		Repair	— • —			102,100 102,116	D
0503	Hub and Blade Assy, Main Rotor	Inspect	— • —				
		Adjust	— • —			101,102	L
		Align	— • —			T34, T39 T40, T41 T49, T62 101,102	
		Replace	— • —			T11, T12 T13, T22 T34, T41 T49, T53 102,101	



MAINTENANCE ALLOCATION CHART							
(AVSCOM Reg 310-10)							
NOMENCLATURE OF END ITEMS							
HELICOPTER, UTILITY - TACTICAL TRANSPORT UH-1H/UH-1V/EH-1H							
(1) GROUP NUMBER	(2) COMPONENT ASSEMBLY	(3) MAINTENANCE FUNCTION	(4) MAINTENANCE CATEGORY			(5) TOOLS AND EQUIPMENT	(6) REMARKS
			AVUM	AVIM	DEPOT		
0503 01	Hub Assembly	Inspect	— ● —				
		Service	— ● —				
		Adjust		— ● —		T34, T41, T49, T59, T62, 102, 116	
		Align	— ● —			102, 109 101	K
		Replace	— ● —			102, 109 101	
		Repair	— ● —			100, 102	M
		Overhaul		— ● —			T34, T41, T49, T72 109, 102
0503 01 01	Drag Brace Assy	Inspect	— ● —				
		Replace	— ● —			102, 109, 101	
		Repair	— ● —			102, 109, 101	
0503 01 02	Grip Assembly	Inspect	— ● —				
		Replace			— ● —		
		Repair	— ● —			109, 100 102	M
				— ● —		102, 113	D

**MAINTENANCE ALLOCATION CHART**

(AVSCOM Reg: 310-10)

NOMENCLATURE OF END ITEMS

HELICOPTER, UTILITY - TACTICAL TRANSPORT UH-1H/UH-1V/EH-1H

(1) GROUP NUMBER	(2) COMPONENT ASSEMBLY	(3) MAINTENANCE FUNCTION	(4) MAINTENANCE CATEGORY			(5) TOOLS AND EQUIPMENT	(6) REMARKS
			AVUM	AVIM	DEPOT		
0503 01 03	Shield Assembly	Inspect		•			
		Replace		•		113,114 102	
		Repair		•		113,114 102	
0503 01 04	Oil Reservoirs & Sight Glasses	Inspect	•				
		Replace	•			102,109 100	
0503 01 05	Strap Assembly, Tension	Inspect		•			
		Replace		•		113,114 102	
0503 01 06	Pitch Horn Assy	Inspect	•				
		Replace	•			102,109 100	
		Repair	•			102,109 100	
0503 01 07	Trunnion Assembly	Inspect	•				M
		Replace			•		
		Repair	•			109, 100 102	M
				•		102, 114, 113	

MAINTENANCE ALLOCATION CHART (AVSCOM Reg 310-10)							
NOMENCLATURE OF END ITEMS HELICOPTER, UTILITY – TACTICAL TRANSPORT UH-1H/UH-1V/EH-1H							
(1) GROUP NUMBER	(2) COMPONENT/ASSEMBLY	(3) MAINT FUNCTION	(4) MAINTENANCE CATEGORY			(5) TOOLS AND EQPT	(6) REMARKS
			AVUM	AVIM	DEPOT		
0503 01 08	Bolt Assy, Blade Retention	Inspect	- • -				
		Replace	- • -			102,109 100	
		Repair	- • -			102,109 100	
0503 01 09	Pillow Block Assy	Inspect	- • -				
		Service	- • -			100,102	
		Replace			- • -	113,114 102	
		Repair	- • -	- • -		109, 100,102	M
0503 01 10	Yoke Assembly	Inspect	- • -				
		Replace			- • -		
		Repair	- • -			109,100,102	M
0503 01(11)	Plate Assy	Inspect	- • -	- • -		102,113,114	M
		Replace		- • -		102, 109	
0503 02	Blade Assy, Main Rotor	Inspect	- • -				
		Replace	- • -			T34,T45 T49,T85 109, 101 102	
		Repair	- • -			T34,T45 T49,T85 109, 101 102	
		Overhaul				- • -	

MAINTENANCE ALLOCATION CHART							
NOMENCLATURES OF END ITEMS							
HELICOPTER, UTILITY - TACTICAL TRANSPORT UH-IH/UH-1V/EH-IH							
(1) GROUP NUMBER	(2) COMPONENT/ASSEMBLY	(3) MAINTENANCE FUNCTION	(4) MAINTENANCE CATEGORY			(5) TOOLS AND EQUIPMENT	(6) REMARKS
			AVUM	AVIM	DEPOT		
0504	Scissors and Sleeve Assembly	Inspect	- • -				
		Replace	- • -			109, 101 101, T99A	
		Overhaul			- • -		
		Repair	- • -			109,102 100 T36,T37 T38,T50 T58,102 109,113 114	
0504 01	Link Assy. Scissors	Inspect	- • -				
		Replace	- • -			109,100 102	
		Repair	- • -			109,100 102	
0504 02	Scissors Assembly	Inspect	- • -				
		Replace	- • -			109,100 102	
		Repair	- • -			109,100 102 T99A	
0504 03	Hub Assembly	Inspect	- • -				
		Replace		- • -		102,113 114	
		Repair	- • -			109,100 102	D
				- • -		102 113,114	

MAINTENANCE ALLOCATION CHART							
NOMENCLATURE OF END ITEMS							
HELICOPTER, UTILITY - TACTICAL TRANSPORT UH-1H/UH-1V/EH-1H							
(1) GROUP NUMBER	(2) COMPONENT/ASSEMBLY	(3) MAINTENANCE FUNCTION	(4) MAINTENANCE CATEGORY			(5) TOOLS AND EQUIPMENT	(6) REMARKS
			AVUM	AVIM	DEPOT		
0504 04	Sleeve, Collective	Inspect	- • -				
		Replace		- • -			
		Repair	- • -			100 , 109 102	D
		Repair		- • -			
0505	Swashplate and support Assy	Inspect	- • -				
		Replace	- • -			100, 102 109	
		Repair	- • -			100, 102 109	M
		Overhaul			- • -		
0506	Damper Assembly, Stabilizer	Inspect	- • -				
		Service	- • -			100, 102 109	
		Adjust	- • -			100, 102 109	
		Replace	- • -			100, 102 109	
		Repair	- • -			100, 102 109	M
0507	Rotor Installation, Tail	Inspect	- • -				
		Replace	- • -			100, 102 109	
		Repair	- • -			100, 102 109	

MAINTENANCE ALLOCATION CHART							
NOMENCLATURE OF END ITEMS							
HELICOPTER, UTILITY - TACTICAL TRANSPORT UH-1H/UH-1V/EH-1H							
(1) GROUP NUMBER	(2) COMPONENT/ASSEMBLY	(3) MAINTENANCE FUNCTION	(4) MAINTENANCE CATEGORY			(5) TOOLS AND EQUIPMENT	(6) REMARKS
			AVUM	AVIM	DEPOT		
0507 01	Link Assembly	Inspect	- • -				
		Replace	- • -			100, 102, 109	
		Repair	- • -			100, 102, 109	
0507 02	Crosshead	Inspect	- • -				
		Replace	- • -			100, 102, 109	
		Repair	- • -			100, 102, 109	
0507 03	Hub and Blade Assembly	Inspect	- • -				
		Adjust	- • -			100, 102, 109	L
		Align	- • -			T1, T73, T75, T78, T85, 102 100, 109	K
		Replace	- • -			102, 109, 100	M
		Repair	- • -			109, 100	M
0507 03 (01)	Blade Assembly			- • -		102, 113, 114	
		inspect	- • -				
		Replace	- • -			100, 102	
		Repair	- • -			100, 102	D
				- • -		102, 113 114	

MAINTENANCE ALLOCATION CHART (AVSCOM Reg 310-10)							
NOMENCLATURE OF END ITEMS HELICOPTER, UTILITY - TACTICAL TRANSPORT UH-1H/UH-1V/EH-1H							
(1) GROUP NUMBER	(2) COMPONENT/ASSEMBLY	(3) MAINTENANCE FUNCTION	(4) MAINTENANCE CATEGORY			(5) TOOLS AND EQUIPMENT	(6) REMARKS
			AVUM	AVIM	DEPOT		
0507 03 02	Hub Assembly	Inspect	-- • --				
		Service	-- • --			100, 102, 109	
		Adjust	-- • --			T44, 100, 102, 109	
		Replace	-- • --			102, 109, 100	
		Repair	-- • --			102, 109, 100 T43, T44, 102, 113, 114	M
0600	Drive Train						
0601	Transmission and Mast Assembly	Inspect	-- • --				
		Replace	-- • --			T19, T21, T53, 102, 101, 109	
		Repair	-- • --			100, 102, 109, 102, 113	M
0601 01	Mast Assembly	Inspect	-- • --				
		Replace	-- • --			T53, 101 102, 109,	
		Repair	-- • --			100, 102, 109 102,113	M
		Overhaul		-- • --	-- • --		

MAINTENANCE ALLOCATION CHART (AVSCOM Reg 310-10)							
NOMENCLATURE OF END ITEMS HELICOPTER, UTILITY – TACTICAL TRANSPORT UH-1H/UH-1V/EH-1H							
(1) GROUP NUMBER	(2) COMPONENT ASSEMBLY	(3) MAINTENANCE FUNCTION	(4) MAINTENANCE CATEGORY			(5) TOOLS AND EQUIPMENT	(6) REMARKS
			AVUM	AVIM	DEPOT		
0601 01	Spring	Inspect	- • -	- • -			M
		Replace		- • -		102,109	
0601 01 (01)	Upper Bearing Assembly	Inspect	- • -				
		Replace			- • -		
0601 01 03	Support Assy	Inspect	- • -	- • -			M
		Replace		- • -		102,109	



MAINTENANCE ALLOCATION CHART (AVSCOM Reg 310-10)							
NOMENCLATURE OF END ITEMS HELICOPTER, UTILITY – TACTICAL TRANSPORT UH-1H/UH-1V/EH-1H							
(1) GROUP NUMBER	(2) COMPONENT/ASSEMBLY	(3) MAINTENANCE FUNCTION	(4) MAINTENANCE CATEGORY			(5) TOOLS AND EQUIPMENT	(6) REMARKS
			AVUM	AVIM	DEPOT		
0601 02	Transmission Assy.	Inspect	- • -				
		Test	- • -			100, 102	
		Service	- • -			100, 102	
		Replace	- • -			T19, T21 T53, 102, 101, 109	
		Repair	- • -			T19, T21 T53, 100 102, 109	
		Overhaul		- • -		102, 113	
0601 02 01	Pressure Relief Valve	Inspect	- • -				
		Replace	- • -			100,102 109	
		Repair		- • -		102, 113	
0601 02 02	Lines, Fittings, Manifolds, and Screens	Inspect	- • -				
		Replace	- • -			100, 102 109	
		Repair	- • -			100, 102 109	
0601 02 03	Oil Jets	Inspect	- • -				
		Replace	- • -			100, 102 109	



MAINTENANCE ALLOCATION CHART							
NOMENCLATURE OF END ITEMS							
HELICOPTER, UTILITY - TACTICAL TRANSPORT UH-1H/UH-1V/EH-1H							
(1) GROUP NUMBER	(2) COMPONENT/ASSEMBLY	(3) MAINTENANCE FUNCTION	(4) MAINTENANCE CATEGORY			(5) TOOLS AND EQUIPMENT	(6) REMARKS
			AVUM	AVIM	DEPOT		
0601 02 04	Filter Assembly (Primary)	Inspect	- • -				
		Replace	- • -			100, 102 109	
		Repair	- • -			100, 102 109	
0601 02 05	Input Drive Quill	Inspect	- • -				
		Replace	- • -			T31, T57 102, 101 109	
		Repair		- • -		T31, T57 102, 113	
		Overhaul			- • -		
0601 02 06	Offset Quill	Inspect	- • -				
		Replace	- • -			101, 102 109	
		Repair		- • -		T26, 102 113	
		Overhaul			- • -		
0601 02 07	Hydraulic Pump and Tachometer Drive Quill	Inspect	- • -				
		Replace	- • -			T31, 101 102, 109	
		Repair		- • -		T31, 102 113	
		Overhaul			- • -		

MAINTENANCE ALLOCATION CHART							
NOMENCLATURE OF END ITEMS							
HELICOPTER, UTILITY – TACTICAL TRANSPORT UH-1H/UH-1V/EH-1H							
(1) GROUP NUMBER	(2) COMPONENT/ASSEMBLY	(3) MAINTENANCE FUNCTION	(4) MAINTENANCE CATEGORY			(5) TOOLS AND EQUIPMENT	(6) REMARKS
			AVUM	AVIM	DEPOT		
0601 02 08	Tail Rotor Quill	Inspect	- • -				
		Replace	- • -			T31 , T60, 102, 101, 109	
		Repair		- • -		T31, T60, 102, 113	
		Overhaul.			- • -		
0601 02 09	Sight Gages	Inspect	- • -				
		Replace	- • -			100, 102, 109	
0601 02 10	Chip Detector	Inspect	- • -				
		Test	- • -			100,102 109	
		Replace	- • -			100, 102. 109	
0601 02 11	Oil Pump Assembly	Inspect	- • -				
		Test		- • -		102, 113	
		Replace	- • -			102, 101, 109	
		Repair		- • -		102, 113	
		Overhaul			- • -		
0601 02 12	Debris Monitor	Inspect	- • -				
		Test	- • -			100, 102, 107	
		Replace	- • -				

MAINTENANCE ALLOCATION CHART (AVSCOM Reg 310-10)							
NOMENCLATURE OF END ITEMS HELICOPTER, UTILITY – TACTICAL TRANSPORT UH-1H/UH-1V/EH-1H							
(1) GROUP NUMBER	(2) COMPONENT/ASSEMBLY	(3) MAINTENANCE FUNCTION	(4) MAINTENANCE CATEGORY			(5) TOOLS AND EQUIPMENT	(6) REMARKS
			AVUM	AVIM	DEPOT		
0602	Main Drive Shaft (Engine to Trans- mission Bell)	Inspect	-	•	-		
		Service	-	•	-	T29, T48, 100, 102, 109	
		Align	-	•	-	T47, T51 , T53, 100, 102, 109	
		Replace	-	•	-	T29, T48, 100, 102, 109	
		Repair	-	•	-	T29, T48, 100, 102, 109	
		Overhaul				-	•
0603	Main Drive Shaft (Engine to Trans- mission Kaflex)	Inspect	-	•	-		
		Align	-	•	-	T47, T51 , T53, 100, 102, 109	
		Replace	-	•	-	100, 102, 109	
		Repair	-	•	-	100, 102, 109	
		Overhaul				-	•
0604	Oil Cooler	Inspect	-	•	-		
		Replace	-	•	-	100, 102, 109	

MAINTENANCE ALLOCATION CHART (AVSCOM Reg 310-10)								
NOMENCLATURE OF END ITEMS HELICOPTER, UTILITY - TACTICAL TRANSPORT UH-1H/UH-1V/EH-1H								
(1) GROUP NUMBER	(2) COMPONENT/ASSEMBLY	(3) MAINTENANCE FUNCTION	(4) MAINTENANCE CATEGORY			(5) TOOLS AND EQUIPMENT	(6) REMARKS	
			AVUM	AVIM	DEPOT			
0605	External Oil Filter	Inspect	-	•	-			
		Replace	-	•	-	100, 102, 109		
0606	Manifold Assembly	Inspect	-	•	-			
		Replace	-	•	-	100, 102, 109		
		Repair	-	•	-	100, 102, 109		
0607	Tail Rotor Drive Shaft	Inspect	-	•	-			
		Align			-	•	-	102,113
		Replace	-	•	-		100, 102 109	
		Repair	-	•	-		100, 102 109	
0607 0 1	Tail Rotor Drive Shaft Hanger Assy.	Inspect	-	•	-			
		Service	-	•	-			
		Replace	-	•	-		100, 102 109	
		Repair	-	•	-		100, 102, 109,	
		Repair			-	•	-	102, 113, 118

MAINTENANCE ALLOCATION CHART							
NOMENCLATURE OF END ITEMS							
HELICOPTER, UTILITY - TACTICAL TRANSPORT UH-1H/UH-1V/EH-1H							
(1) GROUP NUMBER	(2) COMPONENT/ASSEMBLY	(3) MAINTENANCE FUNCTION	(4) MAINTENANCE CATEGORY			(5) TOOLS AND EQUIPMENT	(6) REMARKS
			AVUM	AVIM	DEPOT		
0607 02	Tail Rotor 42° and 90° Gearbox	Inspect	- • -				
		Service	- • -				
		Replace	- • -			T33,T54 100,102 109	
		Repair	- • -			T2,T30 T34,T54 T55,T60 100,102 109 102,113	M
		Overhaul		- • -	- • -		
0607 02 (01)	Tail Rotor 42° and 90° Gearbox Quills	Inspect	- • -			T-72.1	
		Replace	- • -			101,102 109	AK
		Repair		—		102,113	J
		Overhaul			- • -		
0700	Hydraulic and Pneumatic Systems	Inspect	- • -				
		Test	- • -			T88,100 104	
0701	Cylinder Assy, Main Servo	Inspect	- • -	- • -		111	
		Adjust	- • -			100, 02 104	
		Replace	- • -			104, 00 102	
		Repair	- • -			104,100 102	
		Repair		- • -		102,111	AN

MAINTENANCE ALLOCATION CHART							
NOMENCLATURE OF END ITEMS							
HELICOPTER, UTILITY – TACTICAL TRANSPORT UH-1H/UH-1V/EH-1H							
(1) GROUP NUMBER	(2) COMPONENT/ASSEMBLY	(3) MAINTENANCE FUNCTION	(4) MAINTENANCE CATEGORY			(5) TOOLS AND EQUIPMENT	(6) REMARKS
			AVUM	AVIM	DEPOT		
0701 01	Connecting Link, Clevis Fittings, Plugs	Inspect	- • -				
		Replace	- • -			104,100 102	
0701 02	Servocylinder Assy	Inspect	- • -				
		Adjust	- • -			100,102	
		Replace	- • -			104,102 100	
		Repair	- • -			104,100 102	I
0702	Hoses, Tubing and Fittings	Overhaul		- • -		102,111	J,AN
		Inspect	- • -				
		Replace	- • -			104,100 102	
0703	Switch, Pressure	Inspect	- • -				
		Replace	- • -			104,100 102	
0704	Valve, Directional	Inspect	- • -				
		Replace	- • -			104,100 102	
0705	Filter Assembly	Inspect	- • -				
		Replace	- • -			104,100 102	
		Repair	- • -			104,100 102	



MAINTENANCE ALLOCATION CHART							
NOMENCLATURE OF END ITEMS							
HELICOPTER, UTILITY - TACTICAL TRANSPORT UH-1H\UH-1V/EH-1H							
(1) GROUP NUMBER	(2) COMPONENT/ASSEMBLY	(3) MAINTENANCE FUNCTION	(4) MAINTENANCE CATEGORY			(5) TOOLS AND EQUIPMENT	(6) REMARKS
			AVUM	AVIM	DEPOT		
0706	Valve, Check	Inspect	- • -				
		Replace	- • -			104, 100, 102	
0707	Valve, Safety Relief	Inspect	- • -				
		Replace	- • -			104, 100, 102	
0708	Valve, Irreversible	Inspect	- • -				
		Replace	- • -			104, 100, 102	
		Repair	- • -			104, 100, 102	D
		Overhaul			- • -		
0709	Tank, Hydraulic Fluid	Inspect	- • -				
		Service	- • -			100, 102, 104	
		Replace	- • -			104, 100, 102	
		Repair	- • -			104, 100, 102	AG
0710	Pump, Axial Piston	Inspect	- • -				
		Replace	- • -			104, 100, 102	
		Repair	- • -			104, 100, 102	D
		Overhaul			- • -		



MAINTENANCE ALLOCATION CHART (AVSCOM Reg 310-10)							
NOMENCLATURE OF END ITEMS							
HELICOPTER, UTILITY — TACTICAL TRANSPORT UH-1H/UH-1V/EH-1H							
(1) GROUP NUMBER	(2) COMPONENT/ASSEMBLY	(3) MAINTENANCE FUNCTION	(4) MAINTENANCE CATEGORY			(5) TOOLS AND EQUIPMENT	(6) REMARKS
			AVUM	AVIM	DEPOT		
0802	Miscellaneous Instruments						
0802 01	Clock	Inspect	- • -				
		Adjust	- • -			100, 102, 106	
		Replace	- Ž -			100, 102, 106	
		Overhaul			- Ž -		
0802 02	Free Air Temperature Gage	Inspect	- Ž -				
		Test	- Ž -			100, 102, 106	
		Replace	- Ž -			100, 102, 106	
0802 03	Volt, Load and Amp Meter	Inspect	- Ž -				
		Adjust	- Ž -			100, 102, 106	
		Replace	- Ž -			100, 102, 106	

MAINTENANCE ALLOCATION CHART

(AVSCOM Reg 310-10)

NOMENCLATURE OF END ITEMS

HELICOPTER, UTILITY - TACTICAL TRANSPORT UH-1H/UH-1V/EH-1H

(1) GROUP NUMBER	(2) COMPONENT/ASSEMBLY	(3) MAINTENANCE FUNCTION	(4) MAINTENANCE CATEGORY			(5) TOOLS AND EQUIPMENT	(6) REMARKS
			AVUM	AVIM	DEPOT		
0802 04	Fuel Quantity Indicating System						
0802 04 01	Fuel Quantity Indicator and Amplifier	Inspect	- Ž -				
		Test		- Ž -		101,102 106	AL
		Adjust		- Ž -		102,110	
		Replace	- Ž -			100,102 106	
		Overhaul			- Ž -	100,102 106	
0802 04 02	Fuel Quantity Transmitter	Inspect	- Ž -				
		Replace	- Ž -			100,102 106	
		Repair	- Ž -			100,102, 106	
		Overhaul			- Ž -		
0802 04 03	Tank Sensors, Probes & Units	Inspect		- Ž -		102,110	
		Test		- Ž -		110,102	
		Replace		- Ž -		110,102	

MAINTENANCE ALLOCATION CHART (AVSCOM Reg 310-10)							
NOMENCLATURE OF END ITEMS HELICOPTER, UTILITY - TACTICAL TRANSPORT UH-1H/UH-1V/EH-1H							
(1) GROUP NUMBER	(2) COMPONENT ASSEMBLY	(3) MAINTENANCE FUNCTION	(4) MAINTENANCE CATEGORY			(5) TOOLS AND EQUIPMENT	(6) REMARKS
			AVUM	AVIM	DEPOT		
0803	Flight Instrument						
0803 01	Vertical Velocity Indicator	Inspect	- Ž -				
		Test	- Ž -			100, 102, 106	
		Replace	- Ž -			100, 102, 106	
		Repair	- Ž -			100, 102, 106	
		overhaul			- Ž -		
0803 02	Stand-By Compass	Inspect	- Ž -				
		Adjust	- Ž -			100, 102, 106	
		Replace	- Ž -			100, 02, 106	
0803 03	Airspeed Indicator	Inspect	- Ž -				
		Test	- Ž -			100, 02, 106	
		Replace	- Ž -			100, 102, 106	
		Repair	- Ž -			100, 102, 106	
		Overhaul				- Ž -	

MAINTENANCE ALLOCATION CHART (AVSCOM Reg 310-10)							
NOMENCLATURE OF END ITEMS							
HELICOPTER, UTILITY - TACTICAL TRANSPORT UH-1H/UH-1V/EH-1H							
(1) GROUP NUMBER	(2) COMPONENT/ASSEMBLY	(3) MAINTENANCE FUNCTION	(4) MAINTENANCE CATEGORY			(5) TOOLS AND EQUIPMENT	(6) REMARKS
			AVUM	AVIM	DEPOT		
0803 04	Altimeter Indicator	Inspect	- Ž -				
		Test	- Ž -			100, 102, 106	
		Replace	- Ž -			100, 102, 106	
		Overhaul			- Ž -		
0803 05	Attitude Indicator	Inspect	- Ž -				
		Test	- Ž -			100, 102, 106	
		Replace	- Ž -			100, 102, 106	
		Overhaul			- Ž -		
0803 06	Turn & Slip Indicator	Inspect	- Ž -				
		Test	- Ž -			100, 102, 106	
		Replace	- Ž -			100, 102, 106	
		Overhaul			- Ž -		

MAINTENANCE ALLOCATION CHART (AVSCOM Reg 310-10)							
NOMENCLATURE OF END ITEMS HELICOPTER, UTILITY – TACTICAL TRANSPORT UH-1H/UH-1V/EH-1H							
(1) GROUP NUMBER	(2) COMPONENT/ASSEMBLY	(3) MAINTENANCE FUNCTION	(4) MAINTENANCE CATEGORY			(5) TOOLS AND EQUIPMENT	(6) REMARKS
			AVUM	AVIM	DEPOT		
0803 07	Pitot System	Inspect	- Ž -				
		Test	- Ž -			100, 102, 106	
		Calibrate		- Ž -		102, 110, 118	
		Replace	- Ž -			100, 102, 106	
		Repair	- Ž -			100, 102, 106	
0804	Engine Instruments						
0804 01	Dual Tachometer	Inspect	- Ž -				
		Test	- Ž -			100, 102, 106	
		Replace	- Ž -			100, 102, 106	
		Overhaul			- Ž -		
0804 02	Exhaust Gas Temperature Indicator	Inspect	- Ž -				
		Test	- Ž -			100, 102, 106	
		Replace	- Ž -			100, 102, 106	
		Repair	- Ž -			100, 102, 106	
		Overhaul			- Ž -		

MAINTENANCE ALLOCATION CHART (AVSCOM Reg 310-10)							
NOMENCLATURE OF END ITEMS HELICOPTER, UTILITY - TACTICAL TRANSPORT UH-1H/UH-1V/EH-1H							
(1) GROUP NUMBER	(2) COMPONENT ASSEMBLY	(3) MAINTENANCE FUNCTION	(4) MAINTENANCE CATEGORY			(5) TOOLS AND EQUIPMENT	(6) REMARKS
			AVUM	AVIM	DEPOT		
0804 02 01	Thermocouple Lead Spool Resistor	Inspect	- Ž -				
		Test	- Ž -			100, 102, 106	
		Adjust	- Ž -			100, 102, 106	
		Replace	- Ž -			100, 102, 106	
		Repair	- Ž -			100, 102, 106	
0804 03	Oil Temperature Indicator	Inspect	- Ž -				
		Test	- Ž -			100, 102, 106	
		Replace	- Ž -			100, 102, 106	
		Repair	- Ž -			100, 102, 106	
		Overhaul			- Ž -		
0804 04	Oil Pressure Indicator and Transmitter	Inspect	- Ž -				
		Test	- Ž -			100, 102, 106	
		Replace	- Ž -			100, 102, 106	
		Repair	- Ž -			100, 102, 106	
		Overhaul			- Ž -		



MAINTENANCE ALLOCATION CHART (AVSCOM Reg 310-10)							
NOMENCLATURE OF END ITEMS HELICOPTER, UTILITY – TACTICAL TRANSPORT UH-1H/UH-1V/EH-1H							
(1) GROUP NUMBER	(2) (COMPONENT/ASSEMBLY)	(3) MAINTENANCE FUNCTION	(4) MAINTENANCE CATEGORY			(5) TOOLS AND EQUIPMENT	(6) REMARKS
			AVUM	AVIM	DEPOT		
0804 05	Fuel Pressure Indicator and Transmitter	Inspect	-	Ž	-		
		Test	-	Ž	-	100, 102, 106	
		Replace	-	Ž	-	100, 102, 106	
		Repair	-	Ž	-	100, 102, 106	
		Overhaul				-	Ž
0804 06	Torquemeter and Transmitter	Inspect	-	Ž	-		
		Test	-	Ž	-	100, 102, 106	
		Replace	-	Ž	-	100, 102, 106	
		Repair	-	Ž	-	100, 102, 106	
		Overhaul				-	Ž
0804 07	Tachometer Generators	Inspect	-	Ž	-		
		Test	-	Ž	-	100, 102, 106	
		Replace	-	Ž	-	100, 102, 106	
		Repair	-	Ž	-	100, 102, 106	
		Overhaul				-	Ž

SAV-HQ Form 19 Edition of 1 Jul 76, is obsolete  
1 Apr 77

MAINTENANCE ALLOCATION CHART (AVSCOM Reg 310-10)							
NOMENCLATURE OF END ITEMS HELICOPTER, UTILITY - TACTICAL TRANSPORT UH-1H/UH-1V/EH-1H							
(1) GROUP NUMBER	(2) COMPONENT/ASSEMBLY	(3) MAINTENANCE FUNCTION	(4) MAINTENANCE CATEGORY			(5) TOOLS AND EQUIPMENT	(6) REMARKS
			AVUM	AVIM	DEPOT		
0804 08	Gas Producer Tachometer	Inspect	- Ž -				
		Test	- Ž -			100, 102, 106	
		Replace	- Ž -			100, 102, 106	
		Repair	- Ž -			100, 102, 106	
		Overhaul				- Ž -	
0804 09	Temperature Bulbs	Inspect	- Ž -				
		Test	- Ž -			100, 102, 106	
		Replace	- Ž -			100, 102, 106	
		Repair	- Ž -			100, 102, 106	
0805	Transmission Instruments						
0805 01	Oil Temperature Indicator	Inspect	- Ž -				
		Test	- Ž -			100, 102, 106	
		Replace	- Ž -			100, 102, 106	
		Repair	- Ž -			100, 102, 106	
		Overhaul				- Ž -	

MAINTENANCE ALLOCATION CHART							
NOMENCLATURE OF END ITEMS							
HELICOPTER, UTILITY - TACTICAL TRANSPORT UH-1H/UH-1V/EH-1H							
(1) GROUP NUMBER	(2) COMPONENT/ASSEMBLY	(3) MAINTENANCE FUNCTION	(4) MAINTENANCE CATEGORY			(5) TOOLS AND EQUIPMENT	(6) REMARKS
			AVUM	AVIM	DEPOT		
0805 02	Oil Pressure Indicator and Transmitter	Inspect	-	Ž	-		
		Test	-	Ž	-	100, 102, 106	
		Replace	-	Ž	-	100, 102, 106	
		Repair	-	Ž	-	100, 102, 106	
		Overhaul				-	Ž
0900	Electrical System						
0901	Wiring	Inspect	-	Ž	-		
		Test	-	Ž	-	100, 102, 107	
		Replace	-	Ž	-	100, 102, 107	
		Repair	-	Ž	-	100, 102, 107	
0902	Relays, Rheostats, Switches, Circuit Breakers, Plugs, Leads, Connectors, Conduits, Receptacles, Shunts & Shock Mounts	Inspect	-	Ž	-		
		Test	-	Ž	-	100, 102, 107	
		Replace	-	Ž	-	100, 102, 107	
		Repair	-	Ž	-	100, 102, 107	

MAINTENANCE ALLOCATION CHART (AVSCOM Reg 310-10)							
NOMENCLATURE OF END ITEMS HELICOPTER, UTILITY - TACTICAL TRANSPORT UH-1H/UH-1V/EH-1H							
(1) GROUP NUMBER	(2) COMPONENT/ASSEMBLY	(3) MAINTENANCE FUNCTION	(4) MAINTENANCE CATEGORY			(5) TOOLS AND EQUIPMENT	(6) REMARKS
			AVUM	AVIM	DEPOT		
0903	Battery	Inspect	- Ž -				
		Test	- Ž -			100, 102, 107	O
		Service		- Ž -		102, 110	O
		Replace	- Ž -			100, 102, 107	
		Repair	- Ž -			100, 102, 107	O
0904	Regulator	Inspect	- Ž -				
		Adjust	- Ž -			100, 102, 107	AG
		Replace	- Ž -			100, 102, 107	
		Overhaul			- Ž -		
0904.1	Deleted						
0905	Main Generator	Inspect	- Ž -				
		Test		- Ž -		102, 110 T99.2	P
		Replace	- Ž -			100, 102, 107	
		Repair		- Ž -		102, 110	P

MAINTENANCE ALLOCATION CHART							
NOMENCLATURE OF END ITEMS							
HELICOPTER, UTILITY - TACTICAL TRANSPORT UH-1H/UH-1V/EH-1H							
(1) GROUP NUMBER	(2) COMPONENT/ASSEMBLY	(3) MAINTENANCE FUNCTION	(4) MAINTENANCE CATEGORY			(5) TOOLS AND EQUIPMENT	(6) REMARKS
			AVUM	AVIM	DEPOT		
0906	Deleted						
0907	Starter Generator	Inspect	- Ž -				
		Test		- Ž -		102,110 T99.2	P
		Replace	- Ž -			100,102 107	
		Repair		- Ž -		102,110 T99.2	P

MAINTENANCE ALLOCATION CHART							
NOMENCLATURE OF END ITEMS							
HELICOPTER. UTILITY - TACTICAL TRANSPORT UH-1H/UH-1V/EH-1H							
(1) GROUP NUMBER	(2) COMPONENT/ASSEMBLY	(3) MAINTENANCE FUNCTION	(4) MAINTENANCE CATEGORY			(5) TOOLS AND EQUIPMENT	(6) REMARKS
			AVUM	AVIM	DEPOT		
0909	Inverters	Inspect	- Ž -				
		Adjust	- Ž -			100,102 107	
		Replace	- Ž -			100,102 107	
		Repair		- Ž -		102,110	R
0910	A.C. Transformer	Inspect	- Ž -				
		Replace	- Ž -			100,102 107	
		Repair	- Ž -			100,102 107	
0911	Lights						
0911 01	Navigational, Instrument, Interior Cabin, and Anti-collision	Inspect	- Ž -				
		Test	- Ž -			100,102 107	
		Replace	- Ž -			100,102 107	
		Repair	- Ž -			100,102 107	
0911 02	Flasher Unit	Inspect	- Ž -				
		Test	- Ž -			100,102, 107	
		Replace	- Ž -			100,102 107	
		Repair	- Ž -			100,102 107	

MAINTENANCE ALLOCATION CHART							
NOMENCLATURE OF END ITEMS							
HELICOPTER, UTILITY – TACTICAL TRANSPORT UH-1H/UH-1V/EH-1H							
(1) GROUP NUMBER	(2) COMPONENT/ASSEMBLY	(3) MAINTENANCE FUNCTION	(4) MAINTENANCE CATEGORY			(5) TOOLS AND EQUIPMENT	(6) REMARKS
			AVUM	AVIM	DEPOT		
0911 03	Search Light Assembly	Inspect	- Ž -				
		Test	- Ž -			100, 102, 107	
		Replace	- Ž -			100, 102, 107	
		Repair	- Ž -			100, 102, 107	
		Overhaul				- Ž -	
0911 04	Landing Light Assembly	Inspect	- Ž -				
		Test	- Ž -				
		Replace	- Ž -			100,102,107	
		Repair		- Ž -		102,110	
0912	Control Panels	Inspect	- Ž -				
		Replace	- Ž -			100, 102, 107	
		Repair	- Ž -			100, 102, 107	
0913	Caution Panels	Inspect	- Ž -				
		Replace	- Ž -			100, 102, 107	
		Repair	- Ž -			100, 102, 107	AI
0914	RPM Warning Control Box	Inspect	- Ž -			102, 110	
		Test	- Ž -				
		Adjust	- Ž -				
		Replace	- Ž -			100, 102, 107	
		Repair	- Ž -			100, 102, 107	AI
		Overhaul				- Ž -	

MAINTENANCE ALLOCATION CHART								
NOMENCLATURE OF END ITEMS								
HELICOPTER, UTILITY - TACTICAL TRANSPORT UH-1H/UH-1V/EH-1H								
(1) GROUP NUMBER	(2) COMPONENT/ASSEMBLY	(3) MAINTENANCE FUNCTION	(4) MAINTENANCE CATEGORY			(5) TOOLS AND EQUIPMENT	(6) REMARKS	
			AVUM	AVIM	DEPOT			
0915	Chip Detector System	Inspect	- Ž -					
		Replace	- Ž -			100, 102, 107		
0916	Elector-Mechanical Linear Actuator	Repair	- Ž -			100, 102, 107	IEH-1H Only	
		Inspect	- Ž -					
		Replace	- Ž -			109, 102, 107		
		Repair	- Ž -			00, 102, 107		
0917	Alternator, 30 KVA	Overhaul			- Ž -		IEH-1H Only	
		Inspect	- Ž -					
		Test		- Ž -		102, 110		P
		Replace	- Ž -			100, 102, 107		
1000	Fuel Systems	Overhaul			- Ž -		Q	
		Test	- Ž -					
1001	Pump, Submerged Fuel Booster	Inspect	- Ž -					
		Test	- Ž -					
		Replace	- Ž -			102, 100		
		Repair	- Ž -			102, 100		
		Overhaul			- Ž -			



MAINTENANCE ALLOCATION CHART							
NOMENCLATURE OF END ITEMS							
HELICOPTER, UTILITY - TACTICAL TRANSPORT UH-1H/UH-1V/EH-1H							
(1) GROUP NUMBER	(2) COMPONENT/ASSEMBLY	(3) MAINTENANCE FUNCTION	(4) MAINTENANCE CATEGORY			(5) TOOLS AND EQUIPMENT	(6) REMARKS
			AVUM	AVIM	DEPOT		
1002	Hoses and Tubing	Inspect	- Ž -				
		Replace	- Ž -			102, 100	
1003	Adapters and Fittings	Inspect	- Ž -				
		Replace	- Ž -			102, 100	
1004	Valve, Safety Relief	Inspect	- Ž -				
		Replace	- Ž -			102, 100	



MAINTENANCE ALLOCATION CHART (AVSCOM Reg 310-10)							
NOMENCLATURE OF END ITEMS HELICOPTER, UTILITY - TACTICAL TRANSPORT UH-1H/UH-1V/EH-1H							
(1) GROUP NUMBER	(2) COMPONENT/ASSEMBLY	(3) MAINTENANCE FUNCTION	(4) MAINTENANCE CATEGORY			(5) TOOLS AND EQUIPMENT	(6) REMARKS
			AVUM	AVIM	DEPOT		
1005	Cock, Drain	Inspect	-	Ž	-		
		Replace	-	Ž	-		102, 100
1006	Valve, Check	Inspect	-	Ž	-		
		Replace	-	Ž	-		102, 100
1007	Filter Assembly	Inspect	-	Ž	-		
		Replace	-	Ž	-		102, 100
		Repair	-	Ž	-		102, 100
1008	Valve, Gate	Inspect	-	Ž	-		
		Test	-	Ž	-		102, 100
		Replace	-	Ž	-		102, 100
		Overhaul				-	Ž
1009	Valve, Manifold	Inspect	-	Ž	-		
		Replace	-	Ž	-		102, 100
		Overhaul				-	Ž
1010	Transmitter, Pressure	Inspect	-	Ž	-		
		Replace	-	Ž	-		102, 100
1011	Crossover Assemblies	Inspect	-	Ž	-		
		Replace	-	Ž	-		102, 100
		Repair	-	Ž	-		102, 100

MAINTENANCE ALLOCATION CHART (AVSCOM Reg 310-10)							
NOMENCLATURE OF END ITEMS HELICOPTER, UTILITY – TACTICAL TRANSPORT UH-1H/UH-1V/EH-1H							
(1) GROUP NUMBER	(2) COMPONENT/ASSEMBLY	(3) MAINTENANCE FUNCTION	(4) MAINTENANCE CATEGORY			(5) TOOLS AND EQUIPMENT	(6) REMARKS
			AVUM	AVIM	DEPOT		
1012	Cap and Adapter Assy	Inspect	- Ž -				
		Replace	- Ž -			102, 100	
		Repair	- Ž -			102, 100	
1013	Transmitter, Fuel Probe	Inspect	- Ž -				
		Replace	- Ž -			102, 100	
1014	Switch Assembly, Float	Inspect	- Ž -				
		Test	- Ž -			100,102	
		Replace	- Ž -			102, 100	
1015	Tanks, Main Fuel, Both Crashworthy and Non-Crashworthy	Inspect	- Ž -				
		Replace	- Ž -			102,101	AK
		Repair		- Ž -		102	AG
1015	Deleted						
1016	Cross Fitting Assy	Inspect	- Ž -				
		Replace	- Ž -			102, 100	
1017	Pump Assy, Ejector	Inspect	- Ž -				
		Replace	- Ž -			102, 100	

SAV-HQ Form 19 Edition of 1 Jul 76, is obsolete  
1 Apr 77

MAINTENANCE ALLOCATION CHART							
NOMENCLATURE OF END ITEMS							
HELICOPTER, UTILITY – TACTICAL TRANSPORT UH-1H/UH-1V/EH-1H							
(1) Group NUMBER	(2) COMPONENT/ASSEMBLY	(3) MAINTENANCE FUNCTION	(4) MAINTENANCE CATEGORY			(5) TOOLS AND EQUIPMENT	(6) REMARKS
			AVUM	AVIM	DEPOT		
1018	Valve, Flapper	Inspect	- Ž -				
		Replace	- Ž -			102, 100	
1019	Plates, Flapper Valve	Inspect	- Ž -				
		Replace	- Ž -			102, 100	
1020	Sump Assembly	Inspect	- Ž -				
		Replace	- Ž -			102, 100	
		Repair	- Ž -			102, 100	
1021	Tank Assembly, Auxiliary, Internal, Both Crashworthy and Non-Crashworthy	Inspect	- Ž -				
		Service	- Ž -				
		Install	- Ž -			102, 100	
		Replace	- Ž -			102, 100	
		Repair	- Ž -			102, 100	
		Overhaul			- Ž -		
1021 01	Pump, Booster	Inspect	- Ž -				
		Replace	- Ž -			102, 100	
		Repair		- Ž -		102,	
1022	Tank Assembly, Auxiliary, External	Inspect	- Ž -				
		Service	- Ž -			102, 100	
		Replace	- Ž -			102, 100	

MAINTENANCE ALLOCATION CHART							
NOMENCLATURE OF END ITEMS							
HELICOPTER, UTILITY – TACTICAL TRANSPORT UH-1H/UH-1V/EH-1H							
(1) GROUP NUMBER	(2) COMPONENT/ASSEMBLY	(3) MAINTENANCE FUNCTION	(4) MAINTENANCE CATEGORY			(5) TOOLS AND EQUIPMENT	(6) REMARKS
			AVUM	AVIM	DEPOT		
1023	Refuel, Receptacle, Closed Circuit	Inspect	- Ž -			100, 102	
		Repair	- Ž -			102	
		Repair	- Ž -			100, 102	
		Repair	- Ž -				
1100	Flight Controls System						
1101	Main Rotor Control Tubes, Links and Rod Ends	Inspect	- Ž -				
		Adjust	- Ž -			100, 102	
		Replace	- Ž -			100, 102	
		Repair	- Ž -			100, 102	
1102	Flight Control Bearings	Inspect	- Ž -				
		Replace		- Ž -		102,112	
1103	Cyclic Control System						
1103 01	Stick	Inspect	- Ž -				AK
		Adjust	- Ž -			T32, 101, 102	
		Replace	- Ž -			T32, 101, 102	
		Repair	- Ž -			T32, 101, 102	

MAINTENANCE ALLOCATION CHART (AVSCOM Reg 310-10)							
NOMENCLATURE OF END ITEMS HELICOPTER UTILITY - TACTICAL TRANSPORT UH-1H/UH-1V/EH-1H							
(1) GROUP NUMBER	(2) COMPONENT/ASSEMBLY	(3) MAINTENANCE FUNCTION	(4) MAINTENANCE CATEGORY			(5) TOOLS AND EQUIPMENT	(6) REMARKS
			AVUM	AVIM	DEPOT		
1103 02	Tube and Lever Assembly	Inspect	- Ž -				
		Align	- Ž -			100, 102,	
		Replace	- Ž -			100, 102,	
		Repair	- Ž -			T87, 100, 102,	
1103 03	Magnetic Brake	Inspect	- Ž -				
		Adjust	- Ž -			100, 102,	
		Replace	- Ž -			100, 102,	
		Repair		- Ž -			
		Overhaul			- Ž -		AN
1103 04	Force Gradient	Inspect	- Ž -				
		Adjust	- Ž -			100, 102,	
		Replace	- Ž -			100, 102,	
		Repair		- Ž -		102, 112, 118	
1103 05	Mixing Lever Assembly	Inspect	- Ž -				
		Replace	- Ž -			100, 102,	
		Repair	- Ž -			100, 102,	
1103 06	Tubes, Links and Clevises	Inspect	- Ž -				
		Replace	- Ž -			100, 102,	
		Repair		- Ž -		102, 112, 118	

**MAINTENANCE ALLOCATION CHART**  
(AVSCOM Reg 310-10)

NOMENCLATURE OF END ITEMS  
HELICOPTER, UTILITY — TACTICAL TRANSPORT UH-1H/UH-1V/EH-1H

(1) GROUP NUMBER	(2) COMPONENT/ASSEMBLY	(3) MAINTENANCE FUNCTION	(4) MAINTENANCE CATEGORY			(5) TOOLS AND EQUIPMENT	(6) REMARKS
			AVUM	AVIM	DEPOT		
1103 07	Bellcranks, levers, and Supports	Inspect	— • —				
		Replace	— • —			100, 102	
		Repair		— • —		102, 112 118	
1104	Collective Control System						
1104 01	Jackshaft	Inspect	— • —				
		Adjust	— • —			100, 102	
		Replace		— • —		100, 102	
		Repair		— • —		T87, 102 112, 118	
1104 02	Control Assembly	Inspect	— • —				
		Replace	— • —			100, 102	
		Repair		— • —		102, 112 118	
1104 03	Pilot's Stick	Inspect	— • —				
		Adjust	— • —			T32, 101 102	
		Replace	— • —			101, 102	
		Repair	— • —			101, 102	



**MAINTENANCE ALLOCATION CHART**  
(AVSCOM Reg 310-10)

NOMENCLATURE OF END ITEMS  
HELICOPTER, UTILITY — TACTICAL TRANSPORT UH-1H/UH-1V/EH-1H

(1) GROUP NUMBER	(2) COMPONENT/ASSEMBLY	(3) MAINTENANCE FUNCTION	(4) MAINTENANCE CATEGORY			(5) TOOLS AND EQUIPMENT	(6) REMARKS
			AVUM	AVIM	DEPOT		
1104 04	Co-Pilots Stick	Inspect	-- • --				
		Adjust	-- • --			T32,101 102	
		Replace	-- • --			101,102	
		Repair	-- • --			101,102	
1104 05	Control Tubes	Inspect	-- • --				
		Replace	-- • --			100,102	
		Repair	-- • --			100,102	
1104 06	Bellcranks, Levers and Supports	Inspect	-- • --				
		Replace	-- • --			100,102	
		Repair		-- • --		112,102 118,120	
1105	Elevator Control System						
1105 01	Control Tubes	Inspect	-- • --				
		Adjust	-- • --			100,102	
		Replace	-- • --			100,102	
		Repair	-- • --			100,102	

MAINTENANCE ALLOCATION CHART (AVSCOM Reg 310-10)							
NOMENCLATURE OF END ITEMS HELICOPTER, UTILITY - TACTICAL TRANSPORT UH-1H/UH-1V/EH-1H							
(1) GROUP NUMBER	(2) COMPONENT ASSEMBLY	(3) MAINTENANCE FUNCTION	(4) MAINTENANCE CATEGORY			(5) TOOLS AND EQUIPMENT	(6) REMARKS
			AVUM	AVIM	DEPOT		
1105 02	Bellcranks, Levers and Supports	Inspect	- Ž -				
		Replace	- Ž -			100,102	
		Repair		- Ž -		102,112 118,120	
1106	Tail Rotor Control System						
1106 01	Control Cables	Inspect	- Ž -				
		Replace	- Ž -			100,102	
		Repair	- Ž -			101,102	
1106 02	Adjustor Assembly	Inspect	- Ž -				
		Replace	- Ž -			101,102	
		Repair		- Ž -		102,112 118	
1106 03	Control Pulleys	Inspect	- Ž -				
		Replace	- Ž -			100,102	
1106 04	Control Quadrant	Inspect	- Ž -				
		Replace	- Ž -			100,102	
		Repair	- Ž -			100,102	

MAINTENANCE ALLOCATION CHART (AVSCOM Reg 310-10)							
NOMENCLATURE OF END ITEMS HELICOPTER, UTILITY – TACTICAL TRANSPORT UH-1H/UH-1V/EH-1H							
(1) GROUP NUMBER	(2) COMPONENT/ASSEMBLY	(3) MAINTENANCE FUNCTION	(4) MAINTENANCE CATEGORY			(5) TOOLS AND EQUIPMENT	(6) REMARKS
			AVUM	AVIM	DEPOT		
1106 05	Rod and Quill	Inspect	- Ž -				
		Replace	- Ž -			100,102	
		Repair		- Ž -		T43, 102 112,118 120	
1106 07	Force Gradient	Inspect	- Ž -				
		Adjust	- Ž -			100,102	
		Replace	- Ž -			100,102	
		Repair				102,112 118	
1106 08	Control Tubes	Inspect	- Ž -				
		Replace	- Ž -			100,102	
		Repair	- Ž -	- Ž -		100,102	
1106 09	Bellcranks, Levers, and Supports	Inspect	- Ž -				
		Replace	- Ž -			100,102	
		Repair		- Ž -		112,118 120	

MAINTENANCE ALLOCATION CHART (AVSCOM Reg 310-10)							
NOMENCLATURE OF END ITEMS HELICOPTER, UTILITY – TACTICAL TRANSPORT UH-1H/UH-1V/EH-1H							
(1) GROUP NUMBER	(2) COMPONENT/ASSEMBLY	(3) MAINTENANCE FUNCTION	(4) MAINTENANCE CATEGORY			(5) TOOLS AND EQUIPMENT	(6) REMARKS
			AVUM	AVIM	DEPOT		
1106 09	Control Chain (Roller Type)	Inspect	-	Ž	-		
		Adjust	-	Ž	-	100,102	
		Replace	-	Ž	-	100,102	
		Repair	-	Ž	-	100,102	
1200	Utility Systems						
1201	Mirror Assembly	Inspect	-	Ž	-		
		Install	-	Ž	-	102,100	
		Replace	-	Ž	-	102,100	
		Repair	-	Ž	-	102,100	
1202	Windshield Wiper Assembly						
1202 01	Blade and Arm	Inspect	-	Ž	-		
		Replace	-	Ž	-	102,100	
1202 02	Motor and Converter Assembly	Inspect	-	Ž	-		
		Adjust	-	Ž	-	100,102	
1202 02 01	Motor Assembly	Inspect	-	Ž	-		
		Replace	-	Ž	-	102,100	
		Repair	-	Ž	-	102,100	

MAINTENANCE ALLOCATION CHART (AVSCOM Reg 310-10)							
NOMENCLATURE OF END ITEMS HELICOPTER, UTILITY - TACTICAL TRANSPORT UH-1H/UH-1V/EH-1H							
(1) GROUP NUMBER	(2) COMPONENT/ASSEMBLY	(3) MAINTENANCE FUNCTION	(4) MAINTENANCE CATEGORY			(5) TOOLS AND EQUIPMENT	(6) REMARKS
			AVUM	AVIM	DEPOT		
1202 02 02	Converter Assy	Inspect	-	Ž	-		
		Replace	-	Ž	-	102,100	
		Repair	-	Ž	-	102,100	
1202 02 03	Headguard	Inspect	-	Ž	-		
		Replace	-	Ž	-	102,100	
1203	Detection System, Fire	Inspect	-	Ž	-		
		Test	-	Ž	-	100,102	
1203 01	Wiring	Inspect	-	Ž	-		
		Replace	-	Ž	-	102,100	
1203 02	Fire Detector Control Box	Inspect	-	Ž	-		
		Replace	-	Ž	-	102,100	
1300	Environmental Control Systems						
1301	Distribution System, Bleed Air	Test	-	Ž	-	100,102	Q
1301 01	Hoses, Tubing, Ducts	Inspect	-	Ž	-		
		Replace	-	Ž	-	100,102	
1301 02	Registers and Nozzles	Inspect	-	Ž	-		
		Replace	-	Ž	-	100,102	

MAINTENANCE ALLOCATION CHART (AVSCOM Reg 310-10)							
NOMENCLATURE OF END ITEMS HELICOPTER, UTILITY – TACTICAL TRANSPORT UH-1H/UH-1V/EH-1H							
(1) GROUP NUMBER	(2) COMPONENT ASSEMBLY	(3) MAINTENANCE FUNCTION	(4) MAINTENANCE CATEGORY			(5) TOOLS AND EQUIPMENT	(6) REMARKS
			AVUM	AVIM	DEPOT		
1301 03	Valve Assy, Heating Selector	Inspect	-	Ž	-		
		Replace	-	Ž	-	102, 100	
		Repair	-	Ž	-	102, 100	
1301 04	Thermostatic Switch	Inspect	-	Ž	-		
		Replace	-	Ž	-	102, 100	
1301 05	Valve Assy, Mixing	Inspect	-	Ž	-		
		Replace	-	Ž	-	102, 100	
		Overhaul			-	Ž	-
1301 06	Valve, Air Distribution	Inspect	-	Ž	-		
		Replace	-	Ž	-	102, 100	
		Overhaul			-	Ž	-
1302	Auxiliary Exhaust Heater System (Muff)	Install	-	Ž	-	102, 100	
1302 01	Heat Exchanger	Inspect	-	Ž	-		
		Test	-	Ž	-		
		Replace	-	Ž	-	102, 100	
		Repair	-	Ž	-	102, 100	
		Overhaul			-	Ž	-

MAINTENANCE ALLOCATION CHART (AVSCOM Reg 310-10)							
NOMENCLATURE OF END ITEMS HELICOPTER, UTILITY - TACTICAL TRANSPORT UH-1H/UH-1V/EH-1H							
(1) GROUP NUMBER	(2) COMPONENT/ASSEMBLY	(3) MAINTENANCE FUNCTION	(4) MAINTENANCE CATEGORY			(5) TOOLS AND EQUIPMENT	(6) REMARKS
			AVUM	AVIM	DEPOT		
1302 02	Hoses, Tubing, Ducts	Inspect	-	Ž	-		
		Replace	-	Ž	-	102, 100,	
1302 03	Blower Unit	Inspect	-	Ž	-		
		Replace	-	Ž	-	102, 100	
		Repair	-	Ž	-	102, 100 102, 112	M
1302 04	Valve, Mixing	Inspect	-	Ž	-		
		Replace	-	Ž	-	102, 100	
		Repair	-	Ž	-	102, 100 102, 112	M
1302 05	Plenum Assembly	Inspect	-	Ž	-		
		Replace	-	Ž	-	102, 100	
		Repair	-	Ž	-	102, 100 102, 112	M
1302 06	Switch, Overheat	Inspect	-	Ž	-		
		Replace	-	Ž	-	102, 100	

**MAINTENANCE ALLOCATION CHART**  
(AVSCOM Reg 310-10)

NOMENCLATURE OF END ITEMS

HELICOPTER UTILITY - TACTICAL TRANSPORT UH-1H/UH-1V/EH -1H

(1) GROUP NUMBER	(2) COMPONENT/ASSEMBLY	(3) MAINTENANCE FUNCTION	(4) MAINTENANCE CATEGORY			(5) TOOLS AND EQUIPMENT	(6) REMARKS
			AVUM	AVIM	DEPOT		
1400	Hoist and Winches						
1401	Rescue Hoist Assembly	Inspect	-	Ž	-		
		Test	-	Ž	-		
		Service	-	Ž	-	100, 102, 107	
		Install	-	Ž	-	100, 102	
		Replace	-	Ž	-	100, 102	
		Repair	-	Ž	-	100, 102, 107	
		Overhaul			-	Ž -	102, 110
1401 01	Post and Locknut	Inspect	-	Ž	-		
		Replace	-	Ž	-	100, 102,	
		Repair	-	Ž	-	100, 102,	
1401 02	Hoist Cable	Inspect	-	Ž	-		
		Replace	-	Ž	-	T5, 100, 102	
1401 03	Guillotine and support	Inspect	-	Ž	-		
		Replace	-	Ž	-	100, 102	
		Repair	-	Ž	-	100, 102	



MAINTENANCE ALLOCATION CHART (AVSCOM Reg 310-10)							
NOMENCLATURE OF END ITEMS HELICOPTER, UTILITY - TACTICAL TRANSPORT UH-1H/UH-IV/EH-1H							
(1) GROUP NUMBER	(2) COMPONENT/ASSEMBLY	(3) MAINTENANCE FUNCTION	(4) MAINTENANCE CATEGORY			(5) TOOLS AND EQUIPMENT	(6) REMARK:
			AVUM	AVIM	DEPOT		
1401 04	Guide Tube	Inspect	-	Ž	-		
		Replace	-	Ž	-	100, 102	
		Repair	-	Ž	-	100, 102	
1401 05	Boom	Inspect	-	Ž	-		
		Replace	-	Ž	-	100, 102	
		Repair	-	Ž	-	100, 102	
1401 06	Trigger Assembly	Inspect	-	Ž	-		
		Replace	-	Ž	-	100, 102, 107	
		Repair	-	Ž	-	100, 102, 107	
1401 07	Side Plates and Roller	Inspect	-	Ž	-		
		Replace	-	Ž	-	100, 102	
		Repair	-	Ž	-	100, 102	

MAINTENANCE ALLOCATION CHART (AVSCOM Reg 310-10)							
NOMENCLATURE OF END ITEMS							
HELICOPTER, UTILITY – TACTICAL TRANSPORT UH-1H/UH-1V/EH-1H							
(1) GROUP NUMBER	(2) COMPONENT/ASSEMBLY	(3) MAINTENANCE FUNCTION	(4) MAINTENANCE CATEGORY			(5) TOOLS AND EQUIPMENT	(6) REMARKS
			AVUM	AVIM	DEPOT		
1401 08	Limit Switches	Inspect	- Ž -				
		Adjust	- Ž -			100, 102, 107	
		Replace	- Ž -			100, 102, 107	
		Repair	- Ž -			100, 102, 107	
1401 09	Overload Sensing Relay	Inspect	- Ž -				
		Replace	- Ž -			100, 102, 107	
		Repair	- Ž -			100, 102, 107	
1401 10	Hook and Bumper Assembly	Inspect	- Ž -				
		Replace	- Ž -			100, 102	
		Repair	- Ž -			100, 102	
1401 11	Adapters	Inspect	- Ž -				
		Replace	- Ž -			100, 102	

MAINTENANCE ALLOCATION CHART (AVSCOM Reg 310-10)							
NOMENCLATURE OF END ITEMS HELICOPTER, UTILITY - TACTICAL TRANSPORT UH-1H/UH-1V/EH-1H							
(1) GROUP NUMBER	(2) COMPONENT/ASSEMBLY	(3) MAINTENANCE FUNCTION	(4) MAINTENANCE CATEGORY			(5) TOOLS AND EQUIPMENT	(6) REMARKS
			AVUM	AVIM	DEPOT		
1401 12	Power Cables	Inspect	- Ž -				
		Replace	- Ž -			100, 102, 107	
		Repair	- Ž -			100, 102, 107	
1401 13	Control Box	Inspect	- Ž -				
		Test		- Ž -		102, 110, 118	
		Replace		- Ž -		102, 110, 118	
		Repair		- Ž -		102, 110, 118	
		Overhaul			- Ž -		
1401 14	Control Pendant	Inspect	- Ž -				
		Test		- Ž -		102, 110	
		Replace		- Ž -		102, 110, 118,120	
		Repair		- Ž -		102, 118, 120	
		Overhaul			- Ž -		

MAINTENANCE ALLOCATION CHART (AVSCOM Reg 310-10)							
NOMENCLATURE OF END ITEMS HELICOPTER, UTILITY – TACTICAL TRANSPORT UH-1H/UH-1V/EH-1H							
(1) GROUP NUMBER	(2) COMPONENT/ASSEMBLY	(3) MAINTENANCE FUNCTION	(4) MAINTENANCE CATEGORY			(5) TOOLS AND EQUIPMENT	(6) REMARKS
			AVUM	AVIM	DEPOT		
1401 15	Hoist Drive Unit	Inspect	- Ž -				
		Test	- Ž -				
		Replace	- Ž -			100, 102, 107	
		Repair		- Ž -		102, 110, 112, 118	
		Overhaul				- Ž -	
1401 16	Hoist Cable Storage Drum	Inspect	- Ž -				
		Test	- Ž -				
		Replace	- Ž -			100, 102, 110	
		Repair		- Ž -		102, 110, 112, 120, 119	
1401 17	Rubber Pressure Roller	Inspect	- Ž -				
		Replace	- Ž -			100, 102	
		Repair	- Ž -			100, 102	

<b>MAINTENANCE ALLOCATION CHART</b> (AVSCOM Reg 310-10)							
NOMENCLATURE OF END ITEMS HELICOPTER, UTILITY – TACTICAL TRANSPORT UH-1H/UH-1V/EH-1H							
(1) GROUP NUMBER	(2) COMPONENT/ASSEMBLY	(3) MAINTENANCE FUNCTION	(4) MAINTENANCE CATEGORY			(5) TOOLS AND EQUIPMENT	(6) REMARKS
			AVUM	AVIM	DEPOT		
1401 18	Actuator and Lever	Inspect	- Ž -				
		Replace	- Ž -			100,102	
		Repair	- Ž -			100,102	
		Overhaul			- Ž -		
1401 19	Lower Post Support	Inspect	- Ž -				
		Replace	- Ž -			100,102	
		Repair	- Ž -			100,102	
1402	Cargo Suspension System						
1402 01	Cargo Suspension Assembly	Inspect	- Ž -				
		Test	- Ž -				
		Service	- Ž -			100,102	
		Adjust	- Ž -			100, 102	
		Install	- Ž -			100, 102	
		Replace	- Ž -			100, 102	
		Repair	- Ž -			100, 102	

MAINTENANCE ALLOCATION CHART (AVSCOM Reg 310-10)							
NOMENCLATURE OF END ITEMS HELICOPTER, UTILITY – TACTICAL TRANSPORT UH-1H/UH-1V/EH-1H							
(1) GROUP NUMBER	(2) COMPONENT ASSEMBLY	(3) MAINTENANCE FUNCTION	(4) MAINTENANCE CATEGORY			(5) TOOLS AND EQUIPMENT	(6) REMARKS
			AVUM	AVIM	DEPOT		
1402 02	Release Cables	Inspect	- Ž -				
		Install	- Ž -			100, 102	
		Replace	- Ž -			100, 102	
		Repair	- Ž -			100, 102	
1402 03	Pedal Assembly	Inspect	- Ž -				
		Install	- Ž -			100, 102	
		Replace	- Ž -			100, 102	
		Repair	- Ž -			100, 102	
1402 04	Cargo Hook	Inspect	- Ž -				
		Service	- Ž -			100, 102	
		Adjust	- Ž -			100, 102	
		Install	- Ž -			100, 102	
		Replace	- Ž -			100, 102	
		Repair		- Ž -		102, 112, 118, 120	
1600	Mission Equipment						
1601	Smoke Generator Subsystem	Inspect	- Ž -				
		Service	- Ž -				
		Install	- Ž -			102,100	
		Replace	- Ž -			102,100	

PAGES B-70.1 THROUGH B-70.8 HAVE BEEN DELETED.

MAINTENANCE ALLOCATION CHART (AVSCOM Reg 310-10)									
NOMENCLATURE OF END ITEMS									
HELICOPTER, UTILITY-TACTICAL TRANSPORT UH-1H/UH-1V/EH-1H									
(1) GROUP NUMBER	(2) COMPONENT/ASSEMBLY	(3) MAINTENANCE FUNCTION	(4) MAINTENANCE CATEGORY			(5) TOOLS AND EQUIPMENT	(6) REMARKS		
			AVUM	AVIM	DEPOT				
1403	Rescue Hoist Assembly, High Performance	Inspect	-	.	-				
		Test	-	.	-		107		
		Service	-	.	-		100, 102		
		Install	-	.	-		101,102		
		Replace	-	.	-		101,102		
		Repair	-	.	-		100, 102, 107		
1403 01	Winch Assembly	Repair							
		Overhaul			-	.	-	118	
		Inspect	-	.	-			107, 102 T3	
		Test	-	.	-			00, 102	
		Service	-	.	-				
		Replace	-	.	-			101, 102	
		Repair	-	.	-	-	.	-	107 101,102 107,110
		Overhaul				-	.	-	
1403 01	Limit Switch Drive Assembly	Inspect	-	.	-				
		Adjust	-	.	-		101,102		
		Replace	-	.	-		101,102		
		Repair	-	.	-		101,102 107,T3		
		Test	-	.	-		110		

MAINTENANCE ALLOCATION CHART (AVSCOM Reg 310-10)							
NOMECLATURE OF END ITEMS HELICOPTER, UTILITY - TACTICAL TRANSPORT UH-1H/UH-1V/EH-1H							
(1) GROUP NUMBER	(2) COMPONENT/ASSEMBLY	(3) MAINTENANCE FUNCTION	(4) MAINTENANCE CATEGORY			(5) TOOLS AND EQUIPMENT	(6) REMARKS
			AVUM	AVIM	DEPOT		
1403 01 01	Switches and Connector	Inspect	- Ž -				
		Replace	- Ž -			101,102	
1403 01 02	Motor Assembly	Inspect	- Ž -	- Ž -	- Ž -	110	AO
		Test				107, T3	
		Repair	- Ž -			101,102	
		Replace	- Ž -			107	
1403 01 03	Brake Assembly	Inspect	- Ž -				
		Test				101, 102 107	
		Replace	- Ž -			101, 102 107	
		Overhaul			- Ž -		
1403 01 04	Chain	Inspect	- Ž -				
		Adjust	- Ž -			101,102	
		Replace	- Ž -			101,102	
1403 01 05	Cable Hook Assembly	Inspect	- Ž -				
		Service	- Ž -			100, 102	
		Replace	- Ž -			101,102	
		Repair	- Ž -			101,102	



MAINTENANCE ALLOCATION CHART (AVSCOM Reg 310-10)								
NOMENCLATURE OF END ITEMS HELICOPTER, UTILITY - TACTICAL TRANSPORT UH-1H/UH-1V/EH-1H								
(1) GROUP NUMBER	(2) COMPONENT/ASSEMBLY	(3) MAINTENANCE FUNCTION	(4) MAINTENANCE CATEGORY			(5) TOOLS AND EQUIPMENT	(6) REMARKS	
			AVUM	AVIM	DEPOT			
1403 02	Boom Assembly	Inspect	-	.	-			
		Test	-	.	-		101, 102	
		Service	-	.	-		107, T3, 110	
		Adjust	-	.	-		100, 102	
		Align	-	.	-		101, 102 107	
		Repair	-	.	-		101, 102 107	
		Replace				-	.	-
1403 02 01	Up Limit Actuator	Test						
		Inspect	-	.	-		101, 102	
			-	.	-		107	
			-	.	-		101, 102	
		Replace	-	.	-		107 101, 102	
1403 02 02	Cable Assembly	Repair	-	.	-		107 101, 102	
		Inspect	-	.	-		107	
		Replace	-	.	-		101, 102 107	
1403 02 03	Full-Up Limit Switches	Inspect	-	.	-			
		Adjust	-	.	-		101 102 107	
		Adjust	-	.	-		101, 102 107	
		Replace	-	.	-		101, 102 107	
		Repair	-	.	-		101, 102 107	
		Test	-	.	-	-	.	-

MAINTENANCE ALLOCATION CHART							
NOMENCLATURE OF END ITEMS							
HELICOPTER, UTILITY - TACTICAL TRANSPORT UH-1H/UH-1V/EH-1H							
(1) GROUP NUMBER	(2) COMPONENT/ASSEMBLY	(3) MAINTENANCE FUNCTION	(4) MAINTENANCE CATEGORY			(5) TOOLS AND EQUIPMENT	(6) REMARKS
			AVUM	AVIM	DEPOT		
1403 03	Post Structure/Boom Position Actuator Assy	Inspect	- Ž -				
		Test	- Ž -			107,101, T3	
		Service	- Ž -			100, 102,	
		Adjust	- Ž -			101,102 107	
		Replace	- Ž -			101,102 107,	
		Repair	- Ž -			101,102 107	
1403 03 01	Motor	Overhaul		- Ž -		102,110	
		Inspect		- Ž -	- Ž -		
		Test		- Ž -		110,102	
		Replace		- Ž -		102.110	
		Repair		- Ž -		102,110	
		Overhaul			- Ž -		
1403 03 02	Stanchion	Inspect	- Ž -				
		Service	- Ž -			100,102	
		Replace	- Ž -			100, 102,	
		Repair	- Ž -	- Ž -		102, 110 118, 101	
1403 03 03	Mechanical Stop Assembly	Inspect	- Ž -				
		Adjust		- Ž -		102	
		Replace		- Ž -		102	
		Overhaul			- Ž -		

MAINTENANCE ALLOCATION CHART (AVSCOM Reg 310-10)							
NOMENCLATURE OF END ITEMS							
HELICOPTER, UTILITY TACTICAL TRANSPORT UH-1H/UH-1V/EH-1H							
(1) GROUP NUMBER	(2) COMPONENT/ASSEMBLY	(3) MAINTENANCE FUNCTION	(4) MAINTENANCE CATEGORY			(5) TOOLS AND EQUIPMENT	(6) REMARKS
			AVUM	AVIM	DEPOT		
1403 03 04	Rotary Actuator Assy	Inspect	-	Ž	-		
		Test				110	
		Replace				102,110	
		Repair				102, 110	
1403 03 05	Reaction Arm Assembly	Inspect	-	Ž	-		
		Service	-	Ž	-	100,102	
		Overhaul,				102	
		Replace	-	Ž	-	101,102	
		Repair	-	Ž	-	101,102	
1403 03 06	Limit Switches	Inspect	-	Ž	-		
		Adjust	-	Ž	-	107,101	
		Replace	-	Ž	-	101,102 107	
		Repair	-	Ž	-	101,102 107	
1403 03 07	Inertia Dump Assembly	Inspect					
		Adjust				102,110	
		Replace				102,110	
		Repair				102,110	
1403 03 08	Stanchion, Upper	Inspect	-	Ž	-		
		Service	-	Ž	-	100,102	
		Replace	-	Ž	-	101,102	
		Repair				102	

MAINTENANCE ALLOCATION CHART (AVSCOM Reg 310-10)							
NOMENCLATURE OF END ITEMS HELICOPTER, UTILITY - TACTICAL TRANSPORT UH-1H/UH-1V/EH-1H							
(1) GROUP NUMBER	(2) COMPONENT/ASSEMBLY	(3) MAINTENANCE FUNCTION	(4) MAINTENANCE CATEGORY			(5) TOOLS AND EQUIPMENT	(6) REMARKS
			AVUM	AVIM	DEPOT		
1403 04	Control Panel	Inspect	-	Ž	-		
		Test	-	Ž	-	110	
		Replace	-	Ž	-	101,102, 107	
		Repair	-	Ž	-	101,102, 107	
		Overhaul		-	Ž	-	102,110
1403 04 01	Cables	Inspect	-	Ž	-		
		Replace	-	Ž	-	107,101, 102	
		Repair	-	Ž	-	107,101, 102	
1403 04 02	Lamps	Inspect	-	Ž	-		
		Replace	-	Ž	-	101,102	
1403 05	Control Pendant	Inspect	-	Ž	-		
		Test	-	Ž	-	107	
		Replace	-	Ž	-	101,102, 107	
		Repair	-	Ž	-	101,102, 107	
		Overhaul		-	Ž	-	
1403 05 01	Indicator Lamp	Inspect	-	Ž	-		
		Replace	-	Ž	-	100, 102	

MAINTENANCE ALLOCATION CHART (AVSCOM Reg 310-10)							
NOMENCLATURE OF END ITEMS HELICOPTER, UTILITY - TACTICAL TRANSPORT UH-1H/UH-1V/EH-1H							
(1) GROUP NUMBER	(2) COMPONENT/ASSEMBLY	(3) MAINTENANCE FUNCTION	(4) MAINTENANCE CATEGORY			(5) TOOLS AND EQUIPMENT	(6) REMARKS
			AVUM	AVIM	DEPOT		
1600	Mission Equipment						
1601	Smoke Generator Subsystem	Inspect	-	Ž	-		
		Service	-	Ž	-		
		Install	-	Ž	-	102,100	
		Replace	-	Ž	-	102,100	

Edition of 1 Jul 76, is obsolete.

6-70.7/(6-70.8 blank)



MAINTENANCE ALLOCATION CHART (AVSCOM Reg 310-10)							
NOMENCLATURE OF END ITEMS HELICOPTER, UTILITY – TACTICAL TRANSPORT UH-1H/UH-1V/EH-1H							
(1) GROUP NUMBER	(2) COMPONENT/ASSEMBLY	(3) MAINTENANCE FUNCTION	(4) MAINTENANCE CATEGORY			(5) TOOLS AND EQUIPMENT	(6) REMARKS
			AVUM	AVIM	DEPOT		
1602	Curtain Assy, Blackout	Inspect	- Ž -				
		Install	- Ž -			102,100	
		Replace	- Ž -			102,100	
		Repair	- Ž -			102,100	
1603	Paratroop Static Line	Inspect	- Ž -				
		Install	- Ž -			102,100	
		Replace	- Ž -			102,100	
1604	Support Assy, External Stores	Inspect	- Ž -				
		Install	- Ž -			102,100	
		Replace	- Ž -			102,100	
		Repair	- Ž -			102,100	
1605	Heat Suppression (IR)	Inspect	- Ž -				
		Install	- Ž -				
		Replace	- Ž -			102,100	
		Repair	- Ž -			102,100	
1606	Litter Racks	Inspect	- Ž -				UH-1V only
		Install	- Ž -			102,100	
		Replace	- Ž -			102,100	
		Repair	- Ž -			102,100	

MAINTENANCE ALLOCATION CHART							
(AVSCOM Reg 310-10)							
NOMENCLATURE OF END ITEMS							
HELICOPTER, UTILITY - TACTICAL TRANSPORT UH-1H/UH-1V/EH-1H							
(1) GROUP NUMBER	(2) COMPONENT/ASSEMBLY	(3) MAINTENANCE FUNCTION	(4) MAINTENANCE CATEGORY			(5) TOOLS AND EQUIPMENT	(6) REMARKS
			AVUM	AVIM	DEPOT		
1606 01	Strap Assy, Support	Inspect	- Ž -				UH-1V only
		Install	- Ž -			102,100	
		Replace	- Ž -			102,100	
		Repair	- Ž -			102,100	
1606 02	Support	Inspect	- Ž -				UH-1V only
		Install	- Ž -			102,100	
		Replace	- Ž -			102,100	
		Repair	- Ž -			102,100	
1606 03	Belts	Inspect	- Ž -				UH-1V only
		Install	- Ž -			102,100	
		Replace	- Ž -			102,100	
1607	Pylon Assembly, External Stores	Inspect	- Ž -				
		Install	- Ž -			102,100	
		Replace	- Ž -			102,100	
		Repair	- Ž -			102,100	
1608	Armament Subsystem, M60C	Inspect	- Ž -				
		Install	- Ž -			102,100	
		Replace	- Ž -			102, 100	
		Repair	- Ž -				



MAINTENANCE ALLOCATION CHART (AVSCOM Reg 310-10)							
NOMENCLATURE OF END ITEMS HELICOPTER, UTILITY – TACTICAL TRANSPORT UH-1H/UH-1V/EH-1H							
(1) GROUP NUMBER	(2) COMPONENT/ASSEMBLY	(3) MAINTENANCE FUNCTION	(4) MAINTENANCE CATEGORY			(5) TOOLS AND EQUIPMENT	(6) REMARKS
			AVUM	AVIM	DEPOT		
1609	Rack, External Stores	Inspect	- Ž -				
		Install	- Ž -			102,100	
		Replace	- Ž -			102,100	
		Overhaul			- Ž -		
1610	Armament Subsystem, M56	Inspect	- Ž -				
		Adjust	- Ž -				
		Align	- Ž -				
		Install	- Ž -			102,100	
		Replace	- Ž -			102,100	
1610 01	Manual Jettison, External	Inspect	- Ž -				
		Adjust	- Ž -				
		Align	- Ž -				
1610 02	Tube Assy, Strut	Inspect	- Ž -				
		Replace	- Ž -			102,100	
		Repair	- Ž -			102,100	

**MAINTENANCE ALLOCATION CHART**

(AVSCOM Reg 310-10)

NOMENCLATURE OF END ITEMS

HELICOPTER, UTILITY – TACTICAL TRANSPORT UH-1H/UH-1V/EH-1H

(1) GROUP NUMBER	(2) COMPONENT/ASSEMBLY	(3) MAINTENANCE FUNCTION	(4) MAINTENANCE CATEGORY			(5) TOOLS AND EQUIPMENT	(6) REMARKS
			AVUM	AVIM	DEPOT		
1610 02 01	Damper Assembly	Inspect	-	Ž	-	102,100	
		Adjust	-	Ž	-		
		Replace	-	Ž	-		
1610 03	Dispenser, Control Panel	Inspect	-	Ž	-	102,100	T
		Replace	-	Ž	-		
		Repair	-	Ž	-		
1611	Armament Subsystem, M23	Inspect	-	Ž	-	102,100	U
		Replace	-	Ž	-		
		Repair	-	Ž	-		
1611 01	Mount Assembly	Inspect	-	Ž	-	102,100	
		Replace	-	Ž	-		
		Repair	-	Ž	-		

<b>MAINTENANCE ALLOCATION CHART</b> (AVSCOM Reg 310-10)							
NOMENCLATURE OF END ITEMS HELICOPTER, UTILITY – TACTICAL TRANSPORT UH-1H/UH-V/EH-1H							
(1) GROUP NUMBER	(2) COMPONENT ASSEMBLY	(3) MAINTENANCE FUNCTION	(4) MAINTENANCE CATEGORY			(5) TOOLS AND EQUIPMENT	(6) REMARKS
			AVUM	AVIM	DEPOT		
1612	Blood Bottle Hooks	Inspect	- Ž -				UH-1V only
		Replace	- Ž -			102,T100	
1613	Armament Subsystem M130	Inspect	- Ž -				EH-1HX only
		Install	- Ž -			102,T100	
		Replace	- Ž -			100,102	
		Repair	- Ž -			100,102	
1700	Emergency Equipment						
1701	First Aid Kit	Inspect	- Ž -				W
		Replace	- Ž -			102,100	
		Repair	- Ž -				
1702	Fire Extinguisher	Inspect	- Ž -				X
		Replace	- Ž -			102,100	
		Repair	- Ž -				

**MAINTENANCE ALLOCATION CHART**

(AVSCOM Reg 310-10)

NOMENCLATURE OF END ITEMS

HELICOPTER, UTILITY – TACTICAL TRANSPORT UH-1H/UH-1V/EH-1H

(1) GROUP NUMBER	(2) COMPONENT ASSEMBLY	(3) MAINTENANCE FUNCTION	(4) MAINTENANCE CATEGORY			(5) TOOLS AND EQUIPMENT	(6) REMARKS
			AVUM	AVIM	DEPOT		
1702 01	Bracket	Inspect	- Ž -			102,100	
		Replace	- Ž -				
1703	Jettison System, Internal, External Stores	Inspect	- Ž -			102,100	
		Adjust	- Ž -				
		Install	- Ž -				
		Replace	- Ž -				
		Repair	- Ž -				
1800	Installed Avionics Components						R

SECTION III. TOOL AND TEST EQUIPMENT REQUIREMENTS

TOOL OR TEST EQUIPMENT REFERENCE CODE	MAINTENANCE CATEGORY	NOMENCLATURE	NATIONAL STOCK NO.	TOOL NO.
T1	o	Adapter, Balancing	4920-00-168-9797	AA4920-8503
T2	0	<b>Attachment Set, Spanner</b>	<b>SKO</b>	AN8515
T3	0	Multi meter	Toe	AN/URM-105C
<b>T3.1</b>	0	<b>Tester Exhaust Gas</b>	TMDE	<b>BH112JA-53</b>
T4	0	Blind Bolt or Nut	5120-00-733-7119	BH120-1032M3
T5	0	Wrench, Spline		BL-6529
T7	0	Meter, Frequency		JTB Model 33FS
T8		Deleted		
T9		Deleted		
T10		Deleted		
<b>T10.1</b>	F	<b>Tester, PRESSURE</b>	6685-00-693-5009	<b>MP1</b>
T11	o	Wrench, Power	<b>SKO</b>	PD1201
T12	0	Socket, Mast Nut	<b>5120-00-619-9779</b>	PD2659
T13		Adapter, Reaction	<b>5120-00-619-9779</b>	PD2660
T14	0	<b>Replaced by T11</b>		
T15	F	Plate, Anchor	4920-00-713-1366	SWE124330
	F	Socket, Splined	5120-00-619-9774	PD2657
T16	F	Socket, Splined	5120-00-619-9773	PD2658
T17	o	Adapter Arm, Engine	<b>SKO</b>	SWE13852-1210
T19	0	Transmission Adapter	<b>4290-00-676-2307</b>	<b>SWE123852-40</b>
T20	F	Adapter		SWE13852-500
T21	o	Stand, Maintenance		SWE13855
<b>T21.1</b>	0	<b>Mobil Engine Test Unit</b>	TMDE	<b>TE12062</b>
T22	0	Sling, Aircraft, Maintenance	1730-00-099-8099	T100220

TOOL OR TEST EQUIPMENT REFERENCE CODE	MAINTENANCE CATEGORY	NOMENCLATURE	NATIONAL STOCK NUMBER	TOOL NO.
T23	F	Fixture		T100615-13LW
T24	F	Installing tool, seal	<b>5120-00-150-7346</b>	<b>T555-7</b>
T25	F	Fixture, Holding	4920-01-037-7105	T205-076-099-2
T26	F	Thumbscrew Set	5305-00-765-4469	T100929
T27	F	<b>Same as T16</b>		
	F	<b>Same as T16</b>		
T28	F	Adapter	5130-00-676-1681	T101304
	F	Socket, Splined	replaced by 5120-00-619-9774	PD2657
<b>T28.1</b>		<b>Wrench, Transmission</b>	<b>4920 -00-737- 6435</b>	<b>T101305</b>
T29	o	Wrench, Transmission	4920-00-797-3672	T101306
T30	0	Wrench, Tail Rotor	4920-00-718-6533	T101307
T31	0	Jack Screw Set	4920-00-710-7946	T101308
T32	0	Rigging Fixture	1730-00-678-5412	T101330
T33	0	Jack Screw Set	4920-00-765-4410	T101338
T34	0	<b>Build-up Bench</b>	4920-00-678-5431	T101356
T35	0	Fixture, Holding	4920-00-474-0569	T101365
T36	F	Support, Scissors	4920-00-786-1756	T101369
T37	F	Ram, Adapter, Scissors	4920-00-713-5555	T101382
T38	F	Socket, Wrench, Face	5120-01-033-5410 5120-00-033-5090 5120-00-033-2112	PD1469 PD1470 PD1471
T39	o	Support, Rotor Adj.	4920-00-718-6677	T101400
T40	0	Scope Assy, Blade	4920-00-718-6674	T101401

TOOL OR TEST EQUIPMENT REFERENCE CODE	MAINTENANCE CATEGORY	NOMENCLATURE	NATIONAL STOCK NO.	TOOL NO.
T41	o	Link, Grip Positioning	4920-00-718-6673	T101402
T42	o	Plate, Yoke Bearing	4920-00-718-6666	T101406
T43	o	Seal & Bearing Tool	4920-00-793-2134	T101407
T44	F	Tool, Build-up	4920-00-251-2509	T101412
	o	Tool, Grip Spacing	4920-00-251-2509 replaced by	T101457
T45	0	Socket, Wrench	5120-00-044-1426	T101414
T46	0	Hoist Assembly	4920-00-996-0860	T101416
	0	Hoisting Unit, Engine	1730-00-073-9258 replaced by	T101452
T47	0	Tool Set, Align	5120-00-894-6540	T101419
T48	0	Fixture, Holding	4920-00-876-0103	T101420
T49	0	Plate	4920-00-898-0015	T101421
T50	0	Bar, Bearing Removal	4920-00-876-0102	T101424
T51	0	Jack Set	4920-00-805-5123	T101440
T52	0	Socket, Wrench, Face	5120-00-967-7699	T101449
T53	0	Same as T46		
T54	0	Jaw, Puller	5120-00-996-3942	T101455
T55	0	Wrench	5120-00-018-0220	T101456
T56	0	Tool, Grip Spacing	4920-00-251-2509	T101457
T56.1	0	Bending Gage, M/R Blade Trim Tab	5210-00-919-2374	T101485
T56.2	0	Stop, Flap	5210-00-924-7756	T101468
T56.3	0	Support, M/R	4920-00-907-7649	T101467
T56.5	F	Grip Spacing Tool	5220-00-907-7024	T101474

TM 55-1520-210-23-3

TOOL OR TEST EQUIPMENT REFERENCE CODE	MAINTENANCE CATEGORY	NOMENCLATURE	NATIONAL STOCK NUMBER	TOOL NO.
T56.6	F	Bearing Removal Tool	5120-00-907-4889	T101475
T56.7	F	Installing Tool	5120-00-925-5085	T101487
T57	0	Wrench, Input Quill	5120-00-932-3670	T101488
T57.1	F	Bearing Puller	5120-00-999-5306	T101491
T58		Same As T38		
		Same As T38		
T58.1		Same As T38		
T59	0	Gage, Grip Spacing	5120-00-182-3779	T101559
T59.1	F	Installing Tool	5120-00-407-7330	T101586
T60	o	Wrench, Spanner	5120-00-421-7401	T101600
T61		Deleted		
T61.1	0	Lock, M/R	5120-00-451-2956	T101864
T62	0	Positioning Tool	5120-00-477-0874	T101865
T62.1	F	Fixture, Torque	4920-00-491-3559	T41000310-1
T63	F	Adapter, Torque Wrench	5120-00-480-7728	T41000870-1
T64	0	Wrench, Windshield	5120-00-076-4380	XW20509
T65		Cable, Extension	To Be Fabricated	1560-UH1-772-1
T66		Cable, Jumper	To Be Fabricated	1560-UH1-772-2
T67		Wrench, Spanner		204-076-202-100B
T68		Bridge, Automatic, (Simmonds) Capacitance	To Be Fabricated	387011
T69		Field Calibration		387991-003
T70	0	Maintenance Stand	SKO	4920-EG-008
T71		Same As T70		
T72	F	Wrench, Adapter		67SP1275-011
T72.1	F	Installing Tool	5120-00-114-1176	68SAVAED0221



TOOL OR TEST EQUIPMENT REFERENCE CODE	MAINTENANCE CATEGORY	NOMENCLATURE	NATIONAL STOCK NUMBER	TOOL NO.
T73	0	Kit Balancing	TMDE	7A050
T74	0	Wrench, Spanner		7FA18005-50
T75	0	Use T75.1, T75.2, T75.3, T75.4		7HEL053
T75.1	0	Fixture, Support	4920-00-708-3113	2532
T75.2	0	Bushing	4920-00-868-8441	2533
T75.3	0	Bushing	4920-00-708-3115	2529
T75.4	0	Arbor	4920-00-708-3084	2516
T76	0	Use T76.1 and T76.2		7HEL054
T76.1	0	Sleeve, Rotor Hub	4920-00-708-3089	2467
T76.2	0	Fixture, Rotor Hub	4920-00-708-3063	2337
T77	F	Tool Kit Blade Bal	4920-00-856-8214	7HEL061
T78	0	Adapter, Bal	4920-00-937-9418	7HEL065
T78	0	Adapter, Bal	4920-00-168-9797 replaced by	AA4920-8503
T78.1	0	Clevis Assy, Lifting		204-011-178-1
T78.2	0	Adapter, Bal	4920-00-924-5708	7HEL066
T79	0	Spacer		2201
T80	0	Wheel, Hand		2215
T81	0	Arbor, Balancing		2259
T82		Fixture, Rotor Blade	SKO	2337
T83	F	Sleeve, Rotor Hub	4920-00-708-3089	2467
T84		C/O 7HEL061 and 7HEL066		2486
T85	0	Plate, Blade	SKO	2586
T86	0	Adapter C/O 7HEL061	4920-00-536-8218	2588

**TM 55-1520-210-23-3**

TOOL OR TEST EQUIPMENT REFERENCE CODE	MAINTENANCE CATEGORY	NOMENCLATURE	NATIONAL STOCK NUMBER	TOOL NO.
T86.1	0	Torque Fixture		205-076-099-2
T87	0	Reamer		27872-2&11
T88	0	Hydraulic Test Stand	TMDE	D-5A
T89		Fixture, Centering	4920-00-176-4258	205-200-005 1AAT-1
T90		Fixture Locating and Drilling	4920-00-159-8680	71SAVAE-D 0009
T91		Thermometer Tester Electric Field Type		NA-2
T92		Socket		SWE126377
T93		Anchor Plate		SWE124387
T94		Torque Multiplier		SWE103
T95		Ratchet Adapter		SWE67
T96	O	Work Handle	SKO	SWE63
T97		Torque Wrench		SWE54
T98	0	Propeller Protractor	5520-00-212-8747	36D2844
T99.1	F	Tool Kit, Bearing Staking	5180-00-091-8678	T101873
T99.2	F	Test Stand Acft. Gen.	4920-00-697-9969	7199
100	O	Tool Set, AVUM, Set No. 1	4920-00-159-8727	
101	0	Tool Set, AVUM, Set No. 2	4920-00-567-0476	
102	O	Tool Kit, Aircraft Mechanics, General	5180-00-323-4676	
103	O	Tool Kit, Airframe Repairman	5180-00-323-4876	
104	O	Tool Kit, Hydraulic Repairman	5180-00-323-4891	

TOOL OR TEST EQUIPMENT REFERENCE CODE	MAINTENANCE CATEGORY	NOMENCLATURE	NATIONAL STOCK NUMBER	TOOL NO.
106	0	Tool Kit, Instrument Repairmans	5180-00-323- 4913	
107	0	Tool Kit, Electrical Repairmans	5180-00-323- 4915	
108	0	Tool Kit, Eng Repair- mans	5180-00-323-4944	
109	0	Tool Kit, Power Train	5180-00-003-5267	
110	F	Shop Set, AVIM, Electri- cal-Instrument	4920-00-165-1453	
111	F	Shop Set, AVIM, Hydraulic	4920-00-165-1454	
112	F	Shop Set, AVIM, Machine Shop	4920-00-405-9279	
113	F	Shop Set, AVIM, Power Train	4920-00-001-4132	
114	F	Shop Set, AVIM, Propeller Suppl	4920-00-224-3681	
115	F	Shop Set, AVIM, Recip Eng, Suppl	4920-00-464-0222	
116	F	Shop Set, AVIM, Rotor Shop	4920-00-405-9270	
117	F	Shop Set, AVIM, Sheet Metal	4920-00-166-5505	
118	F	Shop Set, AVIM, Tool Crib	4920-00-472-4183	
119	F	Shop Set, AVIM, Turbine Engine	4920-00-224-3684	
120	F	Shop Set, AVIM, Welding	4920-00-163-5093	
121	F	Scales Set, Aircraft Weighing	6670-00-148-9395	

**SECTION IV**

**REMARKS**

REFERENCE CODE	REMARK
A.	Limited to Airframe Repairman Tool Kit and Portable Hand Tools.
B.	Not including build-up.
C.	Limited to Epoxy Minor Repair
D.	Limited to Nicks and Scratches
E	Provided Replacement Fixtures/Tools are utilized and personnel have been trained in proper usage of these fixtures
F.	Not requiring Jigs and Fixtures.
G.	Refer to TM 55-2840-229-23.
H.	Mets Stand
I.	Limited to Dust Boot or Shield.
J.	Limited to Replacement of Packings.
K.	Balance
L.	Track
M.	Limited to Replacement of External Components and External Surface Repair only.
N.	Timing
O.	Refer to TM 11-6140-203-14-2.
P.	Based on Distribution of Generator Test Stand.
Q.	Troubleshooting System
R.	Refer to TM 11-1520-210-20, contains Maintenance Instructions for Avionics.
S.	Refer to TM 9-1005-243-12.
T.	Refer to TM 9-1345-201-10-1.
U.	Refer to TM 9-1005-262-14
V.	Refer to TM 9-1005-262-15
W	By Station Medical Supply Office.

REFERENCE CODE	REMARK
X.	Should be recharged by authorized personnel.
Y.	Excluding the Replacement of Sleeves. UH-18/M
Z.	Limited to Replacement of Rod End Bearing.
AA.	Refer to TM 9-1340-223-34.
AB.	Refer to TM 9-1010-207-12 and TM 9-1010-207-34.
AC.	Refer to TM 9-1005-243-12.
AD.	Refer to TM 9-1400-461-20 and TM 9-1400-461-35.
AE.	Refer to TM 9-1090-201-12.
AF.	Refer to TM 3-6665-267-12 and TM 3-6665-267-35.
AG.	Refer to TM 55-1500-204-25/1.
AH.	Welding.
AI.	Bulb Replacement only.
AJ.	Not used.
AK.	Restricted to AVUM units with 10 or more aircraft. Use extreme care in removal and/or repair.
AL.	If electronic test is required, accomplish with AVIM support.
AN.	Restricted to Non-Divisional Repair.



APPENDIX C

AIRCRAFT INVENTORY MASTER GUIDE

C-1. INTRODUCTION

**C-2. Scope.** Figures C-1 and C-2 list those items of installed or loose equipment required by and authorized for using organizations to accomplish their primary or alternate mission. This list will serve to standardize present inventory procedures, using the inventory master guide to determine the inventoriable items of installed and loose equipment. Insofar as possible, items of equipment are listed in the sequence of their physical location within the aircraft area.

NOTE

Reference Figure C-2 for items added or replaced as a result of MWO 55-1520-210-50-13 through MWO 55-1520-210-50-23.

**C-3. Changes to Inventory.** Aircraft inventory is subject to change as a result of authorized changes (MWO's), addition or deletions of property for special missions requirements; therefore, the selection of items of inventory from the inventory master guide may or may not provide a complete inventory list. When it is known that the master guide does not provide a complete inventory list it will be necessary to research authorized changes (MWO's) and local command directives in order to compile an accurate and exact inventory list

**C-4. Inventory Forms and Records.** Refer to DA PAM 738-751 for applicable forms and records.

C-5. REQUIREMENTS.

**C-6. Security.** It is desired that inventory records be unclassified. Therefore when equipment bearing a security classification or the installation of unclassified equipment is of a confidential or secret nature accomplishment of the classification will be in accordance with security regulations.

**C-7. Inventoriable Items.** Selection of inventoriable items is without regard to the agency, governmental or contractual, furnishing the items.

a. Items to be listed are:

(1) Items essential to the execution of the designated mission of the aircraft such as electronic, photographic, armament, special mission instruments, and safety and comfort equipment,

(2) Loose equipment delivered with the aircraft and items subject to pilferage or readily converted to personal use.

(3) Modification kits which are issued or distributed to using organizations for installation and which are not immediately placed in work will be recorded on the affected aircraft's DA Form 2408-17 (Aircraft Inventory Record) and identified as loose equipment until modification is completed.

(4) Equipment required for operation in special environment.

b. Items to be excluded

(1) Nonaccountable items code as expendable in the applicable stock lists.

(2) Personal issue or furnished on unit allowance or other authority.

(3) Items or components considered as basic or integral parts of the aircraft or basic aircraft such as engines, propellers, wheels and standard instruments.

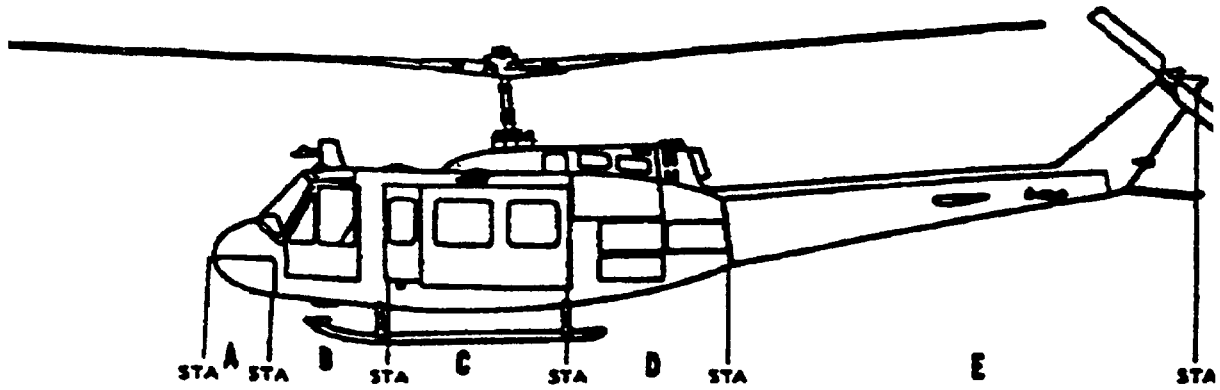
(4) Equipment publications, check lists, and aircraft forms.

**C-8. Periods of Inventory.** Inventoriable items will be checked against the Aircraft Inventory Record (DA Form 2408-17) at the following periods:

a. Upon receipt of the aircraft.

b. Prior to transfer of the aircraft to another organization.

c. Upon placing aircraft in storage and upon removing from storage. Aircraft need not be inventoried while in storage.



A - Nose Compartment  
FS STA 7.6 to STA 23.0

B - Pilots Compartment  
FS STA 23.0 to STA 74.0

C - Cargo Compartment  
FS STA 74.0 to STA 166.0

D - Aft Fuselage Compartment  
FS STA 166.0 to STA 241.0

E - Tail Boom  
FS STA 241.0 to STA 5.08\*

F - Exterior  
FS STA 7.6 to STA 5.08\*

\*Indicates Vertical Fin Station

NOMENCLATURE	Aircraft Series and Quantity of Items Normally Installed				Remarks
	UH-1H	UH-1B	EH-1H	EH-1X	
<b>SECTION A - NOSE COMPARTMENT</b>					
RT-1115/APN-209 Receiver Transmitter, Height Indicator		1			
RT-742( )ARC-51 BX Receiver Transmitter	1	1	1		
AN-ARN 59 ADF Set	1				
RT-348/ARC- 54 FM Transceiver	1	1			
RT-823/ARC-131 FM Transceiver	1	1	1		
BB-433/A Battery	1	1	1	1	If aft, see Section D
R-1388/ARN-82 Receiver	1	1	1		
AM-3209/ASN Servo amplifier	1	1	1	1	
MD-I Displacement Gyro	1	1	1	1	
PU 543/A Inverter	2	2	2	1	
R-1838/APR-39(V) Receiver	1	1	1	1	
R-2097/APR-44(V) Receiver			1	1	
R-2098/APR-44(V) Receiver			1	1	
<b>SECTION B - PILOTS COMPARTMENT</b>					
ID-1917/APN-209 Height Indicator		1			
ID-998/ASN Indicator, RMI	1	1	1	1	
IND-A5-UH-I Indicator, Attitude	1	1	1		
ID 1150/APR-39 Indicator	1	1	1	1	
First Aid Kit	4	4	4	4	
C-1611/AIC Intercom	2		2	2	
C-6533/ARC Intercom		2			
Kit-1A/TSEC Transponder or Kit-1C/TSEC Transponder					

Figure C-1. Inventory Items List Component Diagram (Sheet 1 of 5).



NOMENCLATURE	Aircraft Series and Quantity of Items Normally Installed				Remarks
	UH-1H	UH-1V	EH-1H	EH-1X	
<b>SECTION B - PILOTS COMPARTMENT (Cont')</b>					
Type A-13A Clock	1	1	1	1	
Compass, Pilot Standby	1	1	1	1	
Aircraft Manufactures Data Plate	1	1	1	1	
Pilot Seat and Back Cushions	1	1	1	1	
Copilot Seat and Back Cushions	1	1	1	1	
Pilot Seat Belt and Shoulder Harness	1	1	1	1	
Copilot Seat Belt and Shoulder Harness	1	1	1	1	
Fire Extinguisher: Vaporizing Liquid Type	1	1	1	1	
AN/APN-209 Radar Altimeter		1			
MD-736 Discriminator	4	4	4	4	
14602-1J-F1 Indicator, Attitude	1	1	1		
ID-250/ARN Indicator, Course	1	1	1	1	
C-6280/APX-72 Control	1	1	1	1	
C-9326/APR-39 Control	1	1	1	1	
C-3835/ARC-54 Control	1	1			
C-7088/ARC-131 Control	1	1	1		
C-6287/ARC-51BX Control	1	1	1		
AN/ARC-115 VHF-AM Radio Set	1	1		1	
178061-3 Seat Armored, Pilot	1	1	1	1	
178062-3 Seat Armored, Copilot	1	1	1	1	
Panel, Master Caution	1	1	1	1	
Ignition Keys	2	2	2	2	
Padlock with Key	1	1	1	1	
AAU-32/A AIMS Altimeter	1	1	1	1	
RT-1115/APN-209 Transceiver				1	
ID-1345A/APN-171 Indicator, Radar Altimeter			1		
IP-1156/APR-39 Indicator, Radar Warning			1	1	
AN/ARC-114 Transceiver				1	
ID-1579/ASN-86 Control Indicator				1	
C-8968/ARN-103 Control				1	
C-8157/ARC Control, Panel Voice Security	1	1	1		
AAU-31/A Altimeter	1	1	1	1	
C-7197/ARC-134 Control	1	1	1		
C-6873/ARN-82 Control	1	1	1		
C-G899/ARN-83 Control	1	1	1	1	
C-10048/ARN-123 Control				1	
C-10387/APR-44 Control			1	1	
ID-1347/ARN-82 Indicator			1	1	
J8 Attitude Indicator					
M-130 Dispenser Control			1	1	
M-130 Flare Control			1	1	
C-10547/ARC-164 Control				1	
AOO5G Attitude Indicator					
<b>SECTION C - CARGO COMPARTMENT</b>					
Blood Bottle Hangers	6	6			
Aft Bulkhead Tiedown Fittings	16	16			
Cargo Restraint Device	1	1			
Power Module E1131C	1	1			
C1611/AIC Intercom	2				

Figure C-1. Inventory List Component Diagram (Sheet 2 of 5).

NOMENCLATURE	Aircraft Series and Quantity of Items Normally Installed				Remarks
	UH-1H	UH-1V	Phase 1B, EH-1H	EH-1X	
<b>SECTION C - CARGO COMPARTMENT (Con't)</b>					
Internal Rescue Hoist Fwd Location	1	1			
Passenger Seat 1-Man, Right Hand	1	1			
Passenger Seat 1-Man, Left Hand	1	1			
Passenger Seat Kit, 4 Man	1	1			
Passenger Seat Kit, 3 Man	1	1			
Passenger Seat, 2 Man with Back, Right	1	1			
Passenger Seat, 2 Man with Back, Left	1	1			
Passenger Seat, 1 Man, Bulkhead Mounted	1	1			
Passenger Seat, 2 Man, Beam Mounted, Right	1	1			
Passenger Seat, 2 Man, Beam Mounted, Left	1	1			
G-8385-1 Landing Light	1	1	1	1	
Litter Kit	1	1			
Internal Rescue Hoist, Aft Location	1	1			
Cargo Tiedown Kit	1	1			
Suspension Assembly Cargo	1	1			
AUX Fuel Tank Installation, 200 Gallon	1	1			
AUX Fuel Tank Installation, 120 Gallon	1	1			
Internal Rescue Hoist Provisions Kit	1	1			
C-6533/ARC Intercom		2			
Luggage Compartment Net	1	1			
Blackout Curtain, Cockpit	1	1	1	1	
Blackout Curtain, Window	4	4	4	4	
Utility Light					
Fire Extinguisher				1	
Case Assy Rifle Mount				1	
PP-7472/TLQ-17A(V) Power Supply			1		
T-1386/TLQ-17A(V) Transmitter			1		
OJ-472/ARQ-33A Console Group					
Position 1, Consisting of:					
PP-6875A/UNH-16A Power Supply			1		
RD-385A/UNH-16A Recorder-Reproducer			1		
R-2107/TLQ-17A Receiver			1		
C-8882/ARQ-33 Control			1		
C-1611D/AIC Control Intercom			1		
A-13A2 Clock			1		
5215-5 Seat Operator			1		
Shoulder Harness			1		
Seat Belt			1		
OJ-224/ARQ-33 Console Group					
Position 2, Consisting of:					
C-8883/ARQ Control			1		
C-1611D/AIC Control Intercom			1		
C-7088/ARC Control			1		
ID-1825/ARQ-33 Indicator			1		
PP-6875A/UNH-16A Power Supply			1		
RD-385A/UNH-16A Recorder-Reproducer			1		
TN-496/UR Tuning Unit			1		
TN-456/GLR-9(V) Tuning Unit			1		
IP-779( )/GLR-9(V) Indicator			1		

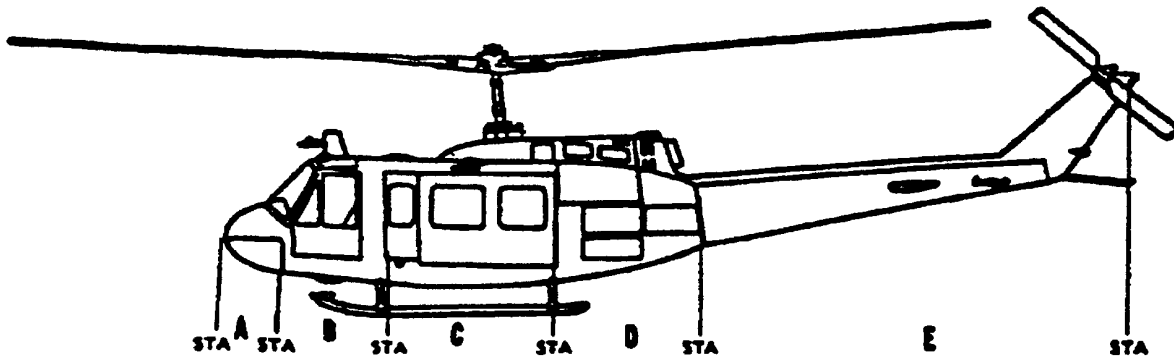
Figure C-1. Inventory Items List Component Diagram (Sheet 3 of 5).

NOMENCLATURE	Aircraft Series and Quantity of Items Normally Installed				Remarks
	UH-1H	UH-1V	Phase 1B, EH-1H	EH-1X	
<b>SECTION C - CARGO COMPARTMENT (Cont')</b>					
ID-2095/GLR-9(V) Indicator			1		
TN-497/UR Tuning Unit			1		
TN-575/GLR-9(V) Tuning Unit			1		
R-1328(V)/GLR-9(V) Receiver			1		
5215-5 Seat, Operator			1		
Shoulder Harness			1		
Shoulder Harness			1		
Seat Belt			1		
CY-7739/GLR-9 Cabinet			1		
MX-8123/ASN-86 Gyro Stabilizer				1	
CP-941/ASN-86 Computer Navigation				1	
CV-2924(P)/ARN-103(V) Converter				1	
RT-1057/ARN-103(V) Converter				1	
Seat Mission Operator				1	
Seat Belt				1	
Shoulder Harness				1	
AN/ALQ-151 Mission Equipment					
Consisting of the following:					
R-2170/TLQ-17A Receiver				1	
PP-7472/TLQ-17A Power Supply				1	
T-1388/TLQ-17A Transmitter				1	
C-10144/ALQ-151 DF Control				1	
C-10026/USQ Control				1	
C-10145/ALQ-151 Control				1	
UYQ-10 Plasma Display				1	
IP-1251 Indicator, Pan				1	
UHY-1 Recorder-Reproducer				1	
PP-6875A/UNH-16A Power Supply				1	
RD-385A/UNH-16A Recorder-Reproducer				1	
C-10050/USQ Control Indicator				1	
TT-580(V)/U Teleprinter				1	
RT-1167/ARC-164 Receiver-Transmitter				2	
TSEC/KY-58 Voice Security				1	
TSEC/KY-45 Voice Security				1	
MX-9855 DF Interface				1	
MX-9781 Processor				1	
UYK-19 Computer				1	
F-1429/ALQ-151 Filter				2	
MX-9/80 RF Processor				1	
C-10027/USQ Control Indicator				1	
C-10025/USQ Control Indicator				1	
R-2017/U Receiver				1	
PP-7292/USQ Power Supply				1	
PP-7293/USQ Power Supply				1	
PP-7294/USQ Power Supply				1	
KY-836/ALQ-151 Keyboard				1	
C-1611D/AIC Control Intercom				1	

Figure C-1. Inventory Items List Component Diagram (Sheet 4 of 5).1

NOMENCLATURE	Aircraft Series and Quantity of Items Normally Installed				Remarks
	UH-1H	UH-1V	Phase 1B, EH-1H	EH-1X	
<b>SECTION C - CARGO COMPARTMENT (Con't)</b>					
C-11002/USQ Control, DF				1	
ID-2090/ALQ-151 Indicator				1	
MX-10250/USQ Processor, RF				1	
MX-10Z51/USQ Processor, Com.				1	
<b>SECTION D - AFT FUSELAGE COMPARTMENT</b>					
AN/ARN-83 ADF Receiver	1	1	1	1	
AN/ARN-30 OMNI Range Receiver	1	1			
Luggage Compartment Net	1	1			
Heater Kit, 100,000 BTU	1	1			
Rotor Blade Anti-Icing Kit	1	1			
AN/ARN-134 VHF	1	1	1		
RT-859/APX-72 Transponder	1	1	1	1	
3949A/U Mount, 1A/T SEC Computer	1	1	1	1	
TS 1843/APX Test Set	1	1	1	1	
CN-998/ASN43 Gyro Directional	1	1	1	1	
J2 Gyro Compass System	1	1			
Heater Kit, Auxilliary 205-706-028-11	1	1			
MIL-R-6809 Regulator, Voltage	2	2	1	1	
BB-433/A Battery (If forward see section A)	1	1	1		
RT-823/ARC-131 FM Receiver-Transmitter			1		
CM-440/APR-39(V) Comparator					
RE-1102/ARQ-33 Power Relay			1		
RE-1104/ARQ-33 Power Relay			1		
PU-543/A Meter Generator			1		
PU-545/A Meter Generator			1		
M-130 Electric Module Assembly			1	1	
M-130 Dispenser with Bracket, Left			1	1	
M-130 Dispenser with Bracket, Right			1	1	
M-130 Payload Module Assy				1	
R-2023/ARN-123 Receiver				1	
<b>SECTION E - TAIL BOOM ASSEMBLY</b>					
RT-804/APN-171(V) Receiver-Transmitter			1		
F-1263/APN-171(V) Filter			1		
R-1838/APR-39(V) Receiver			1	1	
DL1326M31 Linear Actuator			1		
CU-1658A Coupler, Antenna	1	1			
CU-942B/ARC-54 Coupler	1	1			
CN-405/ASN Compensator			1	1	
T-611/ASN Transmitter			1	1	
<b>SECTION F - EXTERIOR</b>					
Rear View Mirror	1	1	1	1	
Fittings, Jack	4	4	4	4	
Searchlight	1	1	1	1	
Main Rotor Blade Tiedown Rig	1	1	1	1	
Tail Rotor Blade Tiedown Rig	1	1	1	1	

Figure C-1. Inventory Items List Component Diagram (Sheet 5 of 5).



- A - Nose Compartment  
FS STA 2.8 to STA 23.0
- B - Pilots Compartment  
FS STA 23.0 to STA 74.0
- C - Cargo Compartment  
FS STA 74.0 to STA 166.0
- D - Aft Fuselage Compartment  
FS STA 166.0 to STA 241.0
- E - Tail Boom  
FS STA 241.0 to STA 5.08\*
- F - Exterior  
FS STA 7.6 to STA 5.08\*

\* Indicates Vertical Fin Station

**NOTE**

The following Inventory Items List identifies equipment that is installed in the aircraft by MWO 55-1520-210-50-13 through MWO 55-1520-210-50-23.

NOMENCLATURE	UH-1H Aircraft Series and Number of Items Normally Installed	Remarks
<b>SECTION A - NOSE COMPARTMENT</b>		
Recvr/Trans RT-1300/ARC-186	1	Replaces AN/ ARC-115 and ARC-134
Mount MT-6050/ARC-186	1	

Figure C-2. UH-1H Inventory Items List Component Diagram (Sheet 1 of 4).  
(With MWO 55-1520-1520-210-50-13 through MWO 55-1520-1520-210-50-23 Installed)

NOMENCLATURE	UH-1H Aircraft Series and Number of Items Normally Installed	Remarks
<b>SECTION A - NOSE COMPARTMENT (CONT'D)</b>		
COMSEC Processor and Mount KY-75	1	Use by-pass cable when KY-75 not installed
Audio Amplifier ASK-9-03707-1	1	Replaces ARC-131
Recvr/Trans RT-1477/ARC-201	1	
Mount MT-6373/ARC-201	1	
GS Antenna AS-3188/ARN	1	Replaces ARN-82, R- 1963, and R-1041
Recvr VOR/ILS R-2023/ARN-123	1	
Adapter Plate 1560-UH1-808	1	Mounts ARN-123
Power Supply, 5V, 156-UH1-872	1	Use with ARC-201 Electroluminescent Panel
Panel Lighting Inverter, 115 VAC (CSK-9-03049-1) Dimmer Network Assembly, 90197092-501	1	Used for ARC-201 panel lighting
	1	
Power Supply, 115V	1	
Battery Box CY-( )/ARC-201	1	
Secure Voice Equipment TSEC/KY-58	1	
<b>SECTION B - PILOTS COMPARTMENT</b>		
Control C-10533/APX-100	1	Replaces APX-72 Control
Control Panel C-10604(V)6 Recvr/Trans RT-1167/ARC-164	1	Replaces AN/ARC-51
	1	
KY-75 Control TSEC/KY-75	1	
HF Volume Control Assembly	1	
Control Display C-11245	1	
Control Panel AN/ARC-199	1	
Control C-11466/ARC-201	1	
Recvr/Trans RT-1476/ARC-201	1	

Figure C-2. UH-1H Inventory Items List Component Diagram (Sheet 2 of 4).  
(With MWO 55-1520-1520-210-50-13 through MWO 55-1520-1520-210-50-23 Installed)

NOMENCLATURE	UH-1H Aircraft Series and Number of Items Normally Installed	Remarks
<b>SECTION B - PILOTS COMPARTMENT (CONT'D)</b>		
Control Unit C-10048/ARN-123 Control Unit C-7329A/ARN-89 HSI Control ID-2103/A HSI Control C-11700/A	1 1 1 1	Used when ASN-128 is installed
Control Display CP-1252/ASN-128	1	
Compass Control C-8021A/ASN-75 Intercommunication Control C-6533/ARC Remote Control Unit Z-AHP Recv/Trans R-1476/ARC-201(V) Discrete Signal Discriminator MD-1219/A	1 2 1 1 1	Replaces Intercom. Control C-1611/AIC and Signal Discriminators MD-1047/A and MD-736/A
Intercommunication Control C-6533/ARC	2	
<b>SECTION C - CARGO COMPARTMENT</b>		
Antenna, Loop (Bottom) AS- 2108/ARN-89 Sense Antenna DSK-9-03189-501	1 1	Replaces 205-075-325. Used only when ASN-128 Doppler Nav. System is installed.
Intercommunication Control C-6533/ARC	2	

Figure C-2. UH-1H Inventory Items List Component Diagram (Sheet 3 of 4).  
(With MWO 55-1520-1520-210-50-13 through MWO 55-1520-1520-210-50-23 Installed)

NOMENCLATURE	UH-1H Aircraft Series and Number of Items Normally Installed	Remarks
<b>SECTION D - AFT FUSELAGE COMPARTMENT</b>		
Recvr/Trans RT-1157/APX-100 (V)	1	Replaces AN/APX-72
Mount MT-4811/APX-100 (V)	1	
Recvr/Exciter RT-1432/U (ARC-199)	1	
Improved FM, AM-7189A/ARC	1	
Gyro, Directional CN998/ASN-43	1	Replaces J-2 Compass
Receiver R-1496A/ARN-89	1	Replaces ARN-83
Amplified Impedance Matching Unit AM-4859/ARN	1	
RT Antenna RT-1193/ASN-128	1	
Signal Data Converter CV-3338/ASN-128	1	
<b>SECTION E - TAIL BOOM</b>		
Antenna Coupler CU-2305/ARC-199	1	
Amplifier Coupler AM-7201/U (ARC-199)	1	
Antenna AS-3839/ARC (Tail) FM-1	1	Replaces AS-1304/ARN
<b>SECTION F - EXTERIOR</b>		
Antenna AT-741 (Top) (IFF)	1	
Antenna AS-3841/ARC (Top) FM-2	1	Replaces AS-1703/ARN
Antenna AS-4137/ARC (HF LOOP)	1	Replaces 205-706-027-1

Figure C-2. UH-1H Inventory Items List Component Diagram (Sheet 4 of 4).  
(With MWO 55-1520-1520-210-50-13 through MWO 55-520-1520-210-50-23 Installed)



APPENDIX D

ILLUSTRATED FIELD MANUFACTURE ITEM LIST

This appendix includes complete instructions, including bills of material, for field manufacture (fabrication) of all items listed in TM 55- 1520-210-23P, Aviation Unit and Intermediate Repair Parts and Special Tools List bearing MO or MF source code. The part number index lists all items in part number order with a cross reference to the figure in which the item appears. All materials necessary for manufacture of all items are listed by National Stock Number in the bill of material for the item.

PART NUMBER	FIGURE NO.
AA8621-2D12	D-351
AA9500-2317-0	D-413
AN257-2-650	D-15
AN6544	D-6
AN6545	D-7
AN6546	D-9
AN6910	D-10
AN6915	D-14
AN743-7	D-4
AN743-12	D-4
AN743-13	D-4
AN8031-8-183	D-5
AN9116-2	D-16
BL6150	D-29
BL8359	D-30
BL8379	D-229
BL8453	D-228
BL8456	D-227
BL8458	D-35
BL8515	D-230
BS-1	D-398
BYRF572	D-52
B56C21	D-56
B79C65	D-55
CSC-536-3	D-18
DK-1	D-401
ES-B-220309	D-391
ES-B-22031	D-390
ES-B-220316	D-396
ES-B-220354	D-388
ES-B-220355	D-387
ES-B-221427	D-386
ES-B-221566	D-385
ES-B-221712	D-384
ES-B-221720	D-375
ES-C-213928	D-383
ES-C-221355	D-372
ES-C-221440	D-382
ES-C-221569	D-381
ES-C-221697	D-374
ES-C-221709	D-380
ES-C-221739	D-379
ES-D-221175	D-397
ES-D-221672	D-389
ES-F-221565	D-377
ES-F-221752	D-378
E1112-32-14	D-225
GRHB-1	D-395
GRHB-2	D-396
HM-1	D-394
IPS-1	D-4
IPS-2	D-4
MS 18029-1S11	D-242
MS 18029-1S10	D-242
MS 18029-1S14	D-242
MS 18029-1S15	D-242
MS 20253-2-225	D-46
MS 20253-2-275	D-46

PART NUMBER	FIGURE NO.
MS 20253-2-600	D-46
MS 20253-2-2450	D-46
MS 20253-2-7950	D-46
MS 20253-2-1035	D-46
MS 20253P2-275	D-46
MS 20253P2-387	D-46
MS 20253P2-538	D-22
MS 20253P2-2372	D-46
MS 25083-2BB5	D-303
MS 25083-2BB6	D-303
MS 27212-1-3	D-37
MS 27212-1-9	D-37
MS 27212-1-10	D-37
MS 27212-1-12	D-37
MS 27212-1-14	D-37
MS 27212-1-15	D-37
MS 27253-2	D-343
MS 28741	D-41
MS 8000	D-41
MS 8001	D-41
MS 87028 Thru	D-41
MS 87032	D-41
NAS 1455-00-3C	D-19
NAS 1455-00-5	D-19
NAS 1455-A-00-4	D-19
NAS 1455-1A2-5	D-19
NAS 1455B00-5	D-19
NAS 42DD4-16	D-2
NAS 42DD6-8	D-2
NAS 43-3-8	D-2
NAS 43-3-24	D-2
NAS 43-3-42	D-2
NAS 43-3-48	D-2
NAS 43-4-12	D-2
NAS 43-4-14	D-2
NAS 43-4-44	D-2
NAS 43-4-108	D-2
NAS 43-5-36	D-2
NAS 43-5-48	D-2
NAS 43-6-12	D-2
NAS 43-6-30	D-2
NAS 43DD1-7	D-2
NAS 43DD1-16	D-2
NAS 43DD3-9	D-2
NAS 43DD3-10	D-2
NAS 43DD3-12	D-2
NAS 43DD3-19	D-2
NAS 43DD3-21	D-2
NAS 43DD3-22	D-2
NAS 43DD3-23	D-2
NAS 43DD3-28	D-2
NAS 43DD3-30	D-2
NAS 43DD3-31	D-2
NAS 43DD3-36	D-2
NAS 43DD3-38	D-2
NAS 43DD3-44	D-2
NAS 43DD3-45	D-2
NAS 43DD3-48	D-2

PART NUMBER	FIGURE NO.
NAS43DD3-50	D-2
NAS43DD3-53	D-2
NAS43DD3-54	D-2
NAS43DD365	D-2
NAS43DD367	D-2
NAS43DD3-70	D-2
NAS43DD3-74	D-2
NAS43DD3-76	D-2
NAS43DD3-80	D-2
NAS43DD3-88	D-2
NAS43DD3-92	D-2
NAS43DD3-96	D-2
NAS43DD3-98	D-2
NAS43DD3-112	D-2
NAS43DD4-10	D-2
NAS43DD4-16	D-2
NAS43DD4-23	D-2
NAS43DD4-28	D-2
NAS43DD4-38	D-2
NAS43DD4-60	D-2
NAS43DD461	D-2
NAS43DD4-71	D-2
NAS43DD5-36	D-2
NAS43DD10-14	D-2
NAS43HT1I-7	D-2
NAS43HT3-12	D-2
NAS43HT3-82	D-2
NAS43HT4-7	D-2
NAS43HT4-28	D-2
NAS521-16-12	D-2
NYLC3	D-57
RB8515-18-3	D-2
SKRV2-1994	D415
SP1152-2	D-640
SP1699-1	D-641
SP1705-1	D-62
SP1706-1	D-63
SP1707-1	D64
SP1707-2	D44
SP1709-2	D65
SP1710-1	D66
SP1715-1	D-67
SP3184-4	D-68
SP3184-5	D68
SP3184-6	D68
SP401-1	D-54
SP401-2	D-54
SP469-1	D-58
SP469-2	D-58
SP516	D-59
STP-41	D411
S8168-44A0170	D-2
UH-1-IS0054-1	D-135
UH-1-LU001-1	D42
UH-1-L0001-2	D42
W20396	D-20
Y1152-1-6	D-225
Y1152-1-11	D-225

PART NUMBER	FIGURE NO.
Y1159-2-3	D-226
100-057-1	D-142
100-057-5	D-143
100337	D-224
106324	D-410
110-0331	D-71
110-119-1	D-134
11021-1	D-219
120-069-1	D-233
120-067B020	D-234
120-067B17	D-234
130-005-5-2	D-232
130-005-6-58	D-232
130-005-7-4	D-232
130405-7-10	D-232
130-005-7-50	D-232
130-005-7C4	D-232
130-005-84	D-232
130-005-96	D-232
1560-UH1	D-395
1560-UH1-711-1	D-363
1560-UH1-760	D-350
1560-UH1-761	D-359
1560-UH1-762-1	D-360
1560-UH1-762-2	D-19
1560-UH1-764	D-361
1560-UH1-765	D-362
1560-UH1-772-1	D-353
1560-UH1-772-2	D-353
1560-UH1-781	D-355
1560-UH1-791	D-356
1560-UH1-981	D-402
1560-UH1-983-3	D-354
1560-UH1-990-1	D-357
1560-UH1-1023	D-368
1560-UH1-1044	D-367
1730-EG179	D407
178036-3	D-176
178038-3	D-176
178040-3	D-176
178042-3	D-176
178044-3	D-176
178050-3	D-176
178050-5	D-176
178050-7	D-176
178052-3	D-176
178052-5	D-176
178052-7	D-176
178065-1	D-220
1951-131-09	D-395
20-032-1	D-21
20432-2	D-21
20432-3	D-21
20-036-8-24	D-69
204-001-222-1	D-11
204-001-790-1	D-81
204401-849-1	D-81

PART NUMBER	FIGURE NO.
204-001-849-2	D-81
204-010-780-1	D-8
204-010-793-3	D-8
204-010-794-1	D-91
204-011-059-1	D-235
204-011-149-1	D-72
204-011-458-1	D-73
204-011-458-3	D-73
204-011-458-5	D-73
204-011-458-7	D-73
204-011-461-1	D-128
204-011-708-1	D-8
204-011-708-3	D-8
204-012-022-3	D-236
204-012-110-1	D-74
204-030-007-139	D-24
204-030-010-1	D-12
204-030-287-89	D-352
204-030-289-91	D-352
204-030-337-3	D-13
204-030-458-4	D-237
204-030-665-11	D-241
204-030-800-443	D-75
204-030-813-5	D-76
204-030-813-2	D-15
204-030-813-23	D-15
204-030-813-25	D-15
204-030-813-27	D-15
204-030-829-15	D-238
204-030-829-27	D-238
204-030-832-7	D-370
204-030-840-1	D-15
204-030-840-3	D-15
204-030-840-5	D-15
204-030-853-73	D-27
204-030-853-83	D-27
204-030-853-93	D-358
204-030-853-85	D-27
204-030-853-97	D-341
204-030-853-98	D-341
204-030-853-99	D-341
204-030-853-100	D-341
204-030-853-111	D-27
204-030-853-113	D-27
204-030-853-115	D-27
204-030-853-117	D-27
204-030-853-133	D-40
205-030-872-21	D-404
205-030-872-23	D-405
204-031-003-13	D-77
204-031-003-14	D-77
204-031-003-23	D-78
204-031-136-17	D-152
2104-031-139-3	D-79
204-031-251-1	D-80
204-031-347-25	D-352
204-031-766-1	D-403

PART NUMBER	FIGURE NO.
204-040-153-13	D-3
204-040-153-15	D-3
204-040-153-25	D-3
204-040-155-11	D-3
204-040-155-13	D-3
204-040-155-15	D-3
204-040-156-5	D-3
204-040-215-19	D-4
204-040-215-27	D-42
204-040-299-1	D-17
204-040-306-9	D-3
204-040-314-5	D-3
204-040-353-11	D-3
204-040-353-13	D-3
204-040-353-15	D-3
204-040-353-17	D-3
204-040-355-11	D-3
204-040-355-13	D-3
204-040-355-15	D-3
204-040-356-5	D-3
204-040-419-7	D-3
204-040-425-5	D-3
204-040-513-11	D-3
204-040-513-13	D-3
204-040-671-1	D-26
204-040-722-1	D-42
204-040-723-1	D-82
204-040-732-1	D-82
204-040-749-1	D-25
204-040-848-1	D-239
204-050-228-1	D-398
204-060-020-207	D-25
204-060-031-15	D-84
204-060-045-1	D-1
204-060-056-1	D-85
204-060-082-1	D-42
204-060-098-1	D-42
204-060-224-9	D-240
204-060-816-33	D-304
204-060-868-5	D-345
204-070-048-7	D-245
204-070-048-13	D-246
204-070-110-3	D-42
204-070-110-7	D-42
204-070-110-65	D-42
204-070-110-67	D-42
204-070-110-71	D-42
204-070-110-153	D-42
204-070-110-155	D-42
204-070-143-3	D-23
204-070-134-11	D-42
204-070-175-1	D-86
204-070-185-1	D-87
204-070-230-1	D-88
204-070-255-1	D-89
204-070-255-2	D-89
204-070-255-13	D-90

PART NUMBER	FIGURE NO.	PART NUMBER	FIGURE NO.
204-070-255-14	D-90	204-070-848-3	D-250
204-070-274-1	D-92	204-070-855-7	D-33
204-070-275-1	D-93	204-070-904-1	D-34
204-070-343-1	D-26	204-071-523-1	D-2
204-070-476-1	D-31	204-071-539-3	D-98
204-070-528-1	D-94	204-071-542-3	D-2
204-070-583-1	D-95	204-071-577-1	D-99
204-070-585-1	D-96	204-072-054-1	D-100
204-070-749-1	D-97	204-072-083-1	D-101
204-070-794-1	D-26	<del>204-072-258-1</del>	D-251
204-070-798-1	D-26	204-072-258-3	D-252
204-070-806-3	D-247	204-072-259-1	D-253
204-070-812-1	D-248	204-072-265-1	D-42
204-070-812-3	D-26	204-072-267-1	D-42
204-070-818-1	D-26	204-072-268-1	D-42
204-070-818-3	D-26	204-072-355-1	D-42
204-070-845-1	D-249	204-072-364-1	D-42
		204-075-143-5	D-36



PART NUMBER	FIGURE NO.
204-075-143-7	D-36
204-075-152-3	D-260
204-075-160-1	D-102
204-075-163-1	D-38
204-075-173-35	D-28
204-075-177-13	D-305
204-075-181-9	D-2
204-075-207-3	D-32
204-075-230-3	D-258
204-075-230-5	D-259
204-075-243-1	D-39
204-075-264-1	D-254
204-075-264-3	D-255
204-075-264-5	D-256
204-075-264-9	D-257
204-075-520-1	D-103
204-076-032-3	D-104
205-001-104-1	D-105
205-030-007-77	D-106
205-030-007-97	D-107
205-030-007-98	D-107
205-030-007-99	D-108
205-030-007-107	D-109
205-030-007-109	D-110
205-030-007-111	D-111
205-030-007-113	D-112
205-030-007-131	D-113
205-030-007-132	D-113
205-030-007-133	D-114
205-030-007-134	D-114
205-030-007-155	D-115
205-030-007-157	D-116
205-030-007-159	D-117
205-030-007-179	D-118
205-030-007-180	D-119
205-030-007-231	D-118
205-030-007-233	D-120
205-030-007-245	D-121
205-030-007-246	D-121
205-030-007-271	D-122
205-030-007-272	D-122
205-030-007-337	D-123
205-030-007-341	D-124
205-030-007-347	D-306
205-030-007-351	D-125
205-030-009-51	D-365
205-030-028-5	D-126
205-030-028-6	D-126
205-030-028-25	D-126
205-030-028-27	D-126
205-030-029-5	D-133
205-030-029-25	D-261
205-030-031-7	D-127

PART NUMBER	FIGURE NO.
205-030-137-4	D-262
205-030-148-3	D-263
205-030-163-25	D-307
205-030-163-125	D-308
205-030-163-129	D-309
205-030-164-215	D-264
205-030-163-231	D-310
205-030-163-329	D-311
205-030-213-4	D-312
205-030-239-3	D-265
205-030-239-5	D-266
205-030-245-13	D-15
205-030-245-15	D-15
205-030-245-43	D-15
205-030-245-45	D-15
205-030-245-61	D-157
205-030-245-67	D-157
205-030-247-25	D-129
205-030-257-15	D-267
205-030-302-5	D-130
205-030-302-6	D-130
205-030-309-13	D-131
205-030-385-17	D-313
205-030-385-18	D-313
205-030-385-21	D-314
205-030-407-121	D-315
205-030-407-317	D-316
205-030-431-1	D-132
205-030-432-1	D-132
205-030-484-15	D-15
205-030-484-17	D-15
205-030-539-7	D-317
205-030-539-11	D-15
205-030-543-15	D-135
205-030-543-17	D-136
205-030-611-15	D-318
205-030-614-13	D-137
205-030-615-93	D-319
205-030-615-94	D-319
205-030-671-7	D-138
205-030-671-9	D-138
205-030-711-27	D-321
205-030-711-28	D-321
205-030-729-49	D-322
205-030-737-3	D-139
205-030-737-5	D-140
295-030-814-17	D-141
205-030-819-21	D-323
205-030-828-1	D-142
205-030-828-5	D-143
205-030-846-33S	D-324
205-030-849-7	D-144

PART NUMBER	FIGURE NO.
205-030-850-21	D-325
205-030-872-21	D-404
205-030-872-23	D-405
205-030-919-33	D-412
205-030-919-37	D-223
205-030-919-38	D-223
205-030-137-1	D-145
205-030-250-3	D-198
205-031-250-13	D-146
205-031-423-31	D-268
205-031-423-32	D-268
205-031-423-33	D-268
205-031-423-34	D-268
205-031-481-15	D-269
205-031-481-23	D-270
205-031-481-29	D-270
205-031-481-33	D-406
205-031-668-43	D-147
205-031-668-51	D-15
205-031-668-53	D-148
205-031-668-65	D-271
205-031-669-101	D-369
205-031-669-105	D-352
205-031-669-137	D-320
205-031-669-151	D-49
205-031-669-152	D-49
205-031-801-53	D-149
205-031-837-19	D-150
205-031-837-20	D-150
205-031-837-21	D-150
205-031-862-17S	D-272
205-031-862-19S	D-273
205-031-862-21S	D-272
205-031-862-47S	D-274
205-031-898-1	D-151
205-040-125-11	D-3
205-040-125-15	D-3
205-040-130-1	D-132
205-040-131-1	D-153
205-040-142-1	D-42
205-040-143-1	D-42
205-040-144-1	D-42
205-040-145-1	D-42
205-040-146-1	D-42
205-040-147-1	D-42
205-040-148-1	D-42
205-040-150-1	D-42
205-040-151-1	D-42
205-040-152-1	D-154
205-040-154-3	D-155
205-040-156-3	D-156
205-040-159-1	D-42
205-040-164-1	D-26
205-040-169-1	D-158
205-040-170-1	D-159
205-040-202-1	D-160
205-040-202-3	D-161

PART NUMBER	FIGURE NO.
205-040-203-1	D-4
205-060-020-7	D-162
205-060-110-1	D-275
205-060-204-1	D-163
205-060-205-19	D-276
205-060-205-20	D-276
205-060-254-9	D-399
205-060-424-1	D-42
205-060-440-1	D-42
205-060-509-3	D-165
205-060-536-1	D-166
295-060-540-19	D-167
205-060-580-1	D-42
205-060-581-1	D-42
205-060-582-1	D-42
205-060-583-1	D-42
205-060-584-1	D-42
205-060-585-1	D-42
205-060-586-1	D-42
205-060-587-1	D-42
205-060-589-1	D-42
205-060-590-1	D-42
205-060-591-1	D-42
205-060-592-1	D-42
205-060-593-1	D-42
205-060-594-1	D-42
205-060-648-1	D-42
205-060-649-1	D-42
205-060-690-1	D-42
205-060-691-1	D-42
205-060-692-1	D-42
205-060-693-1	D-42
205-060-694-1	D-42
205-060-695-1	D-42
205-060-696-1	D-42
205-060-697-1	D-42
205-060-770-1	D-168
205-060-802-11	D-169
205-060-802-13	D-169
205-060-805-13	D-352
205-060-805-35	D-397
205-060-805-37	D-397
205-060-805-41	D-400
205-060-810-15	D-170
205-060-810-16	D-170
205-060-816-33	D-346
205-060-826-79	D-326
205-060-826-81	D-171
205-060-826-83	D-172
205-060-826-85	D-172
205-060-838-1	D-173
205-060-860-3	D-174
205-060-860-4	D-174
205-060-862-1	D-175
205-060-868-5	D-345







PART NUMBER	FIGURE NO.
205-061-521-1	D-332
205-061-600-1	D-42
205-061-601-1	D-42
205-061-604-1	D-42
205-061-606-1	D-42
205-061-607-1	D-42
205-061-608-1	D-42
205-061-609-1	D-42
205-061-610-1	D-42
205-061-611-1	D-42
205-061-612-1	D-42
205-061-614-1	D-42
205-061-615-1	D-42
205-061-616-1	D-42
205-061-617-1	D-42
205-061-618-1	D-42
205-061-619-1	D-42
205-061-624-1	D-42
205-061-643-1	D-179
205-061-643-3	D-333
205-061-645-1	D-42
205-061-647-1	D-42
205-061-649-1	D-42
205-061-650-1	D-42
205-061-651-1	D-42
205-061-652-1	D-42
205-061-653-1	D-42
205-061-654-1	D-42
205-061-655-1	D-42
205-061-659-1	D-42
205-061-661-1	D-42
205-061-662-1	D-42
205-061-663-1	D-42
205-061-664-1	D-42
205-061-665-1	D-180
205-061-666-1	D-181
205-061-668-1	D-42
205-061-669-1	D-42
205-061-670-1	D-42
205-061-671-1	D-42
205-061-672-1	D-182
205-061-674-1	D-42
205-061-675-1	D-42
205-061-677-1	D-183
205-061-684-1	D-184
205-062-614-1	D-42
205-062-662-1	D-42
205-062-663-1	D-42
205-062-680-1	D-42
205-062-681-1	D-42
205-062-696-1	D-277
205-070-054-1	D-334
205-070-226-1	D-26
205-070-365-1	D-42

PART NUMBER	FIGURE NO.
205-070-366-1	D-42
205-070-404-1	D-186
205-070-404-3	D-187
205-070-416-5	D-188
205-070-416-7	D-188
205-070-416-13	D-188
205-070-430-1	D-189
205-070-430-3	D-189
205-070-436-1	D-42
205-070-439-1	D-42
205-070-440-1	D-42
205-070-441-1	D-42
205-070-448-1	D-42
205-070-450-3	D-190
205-070-452-1	D-191
205-070-452-3	D-191
205-070-475-1	D-42
205-070-476-1	D-42
205-070-483-1	D-192
205-070-484-1	D-42
205-070-485-1	D-42
205-070-486-1	D-42
205-070-487-1	D-42
205-070-488-1	D-42
205-070-490-1	D-42
205-070-491-1	D-42
205-070-493-1	D-193
205-070-493-3	D-193
205-070-494-1	D-194
205-070-609-1	D-195
205-070-656-1	D-196
205-070-769-1	D-197
205-070-772-1	D-279
205-070-795-1	D-280
205-070-801-1	D-26
205-070-810-1	D-26
205-070-829-1	D-26
205-070-840-1	D-26
205-070-850-1	D-26
205-070-853-1	D-26
205-070-853-3	D-26
205-070-859-1	D-26
205-070-862-1	D-281
205-070-882-1	D-282
205-070-942-1	D-199
205-072-038-1	D-335
205-072-039-1	D-283
205-072-208-1	D-412
205-072-221-3	D-278
205-072-222-1	D-99
205-071-118-101	D-366
205-071-118-103	D-366
205-071-118-105	D-366
205-071-118-107	D-366

PART NUMBER	FIGURE NO.
205-072-224-1	D-284
205-072-225-1	D-285
205-072-226-1	D-286
205-072-227-1	D-287
205-072-227-3	D-288
205-072-264-1	D-164
205-072-269-3	D-200
205-072-274-3	D-201
205-072-278-1	D-42
205-072-304-1	D-42
205-072-305-1	D-42
205-072-317-1	D-289
205-072-403-1	D-202
205-072-410-1	D-42
205-072-424-1	D-42
205-075-126-1	D-203
205-075-126-9	D-204
205-075-126-13	D-205
205-075-133-1	D-206
205-075-134-1	D-42
205-075-134-1	D-207
205-075-135-15	D-208
205-05-135-19	D-292
205-075-137-3	D-336
205-075-142-3	D-209
205-075-142-5	D-293
205-075-142-9	D-294
205-075-142-11	D-185
205-075-144-3	D-210
205-075-151-1	D-295
205-075-210-3	D-296
205-075-210-5	D-297
205-075-229-1	D-211
205-075-237-5	D-298
205-076-025-11	D-218
205-076-025-15	D-218
205-076-033-1	D-42
205-076-101-1	D-212
205-076-101-3	D-213
205-076-102-1	D-214
205-076-118-1	D-215
205-076-131-1	D-42
205-076-136-1	D-42
205-076-138-1	D-42
205-076-140-1	D-42
205-076-141-1	D-42
205-076-156-1	D-42
205-076-157-1	D-42
205-076-158-1	D-42
205-076-159-1	D-42
205-076-160-1	D-42
205-076-161-1	D-42
205-076-200-1	D-42
205-076-201-1	D-42

PART NUMBER	FIGURE NO.
305-076-202-1	D-42
305-076-203-1	D-42
305-076-204-1	D-42
305-076-205-1	D-42
305-076-206-1	D-42
305-076-207-1	D-42
205-076-208-1	D-42
205-076-209-1	D-42
205-076-210-1	D-42
205-076-212-1	D-42
205-076-213-1	D-42
205-076-214-1	D-42
205-076-215-1	D-42
205-076-216-1	D-42
205-076-217-1	D-42
205-076-221-1	D-42
205-076-223-1	D-42
205-076-227-1	D-42
205-076-230-1	D-216
205-076-231-1	D-42
205-076-232-1	D-42
205-076-233-1	D-42
205-076-234-1	D-217
205-076-235-1	D-42
205-076-236-1	D-42
205-076-237-1	D-42
205-076-238-1	D-42
205-076-240-1	D-42
205-076-241-1	D-42
205-076-242-1	D-42
205-076-244-1	D-42
205-076-245-1	D-42
205-076-246-1	D-42
205-076-247-1	D-42
205-076-248-1	D-42
205-076-249-1	D-42
205-076-250-1	D-42
205-076-251-1	D-42
205-076-252-1	D-42
205-076-253-1	D-42
205-076-254-1	D-42
205-076-255-1	D-42
205-076-257-1	D-42
205-076-258-1	D-42
205-076-259-1	D-42
205-706-025-11	D-218
205-706-025-15	D-218
205-706-025-17	D-337
205-706-025-19	D-338
205-706-029-11	D-290
205-706-029-15	D-291
205-961-102-17	D-299
205-961-102-25	D-300
205-961-102-33	D-301

PART NUMBER	FIGURE NO.
205-961-155-3	D-302
206-010-324-1	D-344
209-040-158-1	D-342
270-580292-12	D-349
28D00	D-43
397-1	D-340
49C16	D-44
50H1	D-45
5065695	D-376
5065696	D-393
5065698	D-392
528307	D-221
5310-UH1-036-1	D-364
5340-UH-1-6821	D-409
5340-UH-1-6823	D-409
59H21	D-47
67SPL12757-0114	D-339
70-017	D-53
70-001B8F18Z3	D-48
70-001B8F59Z3	D-48
70-001B10F66Z2	D-48
70-001B12F13Z3	D-48
70-001B12F22Z2	D-48
70-001B12F27Z2	D-48
70-001B12F52Z3	D-48
70-001B20F12Z3	D-48
70-004A10F23Z2	D-48
70-004A10F24Z2	D-48
70-004A10F25Z3	D-48
70-004A12F27Z2	D-48
70-009-F245Z347	D-41.1
70-010J000A180	D-41
70-010J000G214	D-41
70-010K000H154	D-41
70-010K304Z134	D-41
70-010-3240C484	D-41.2
70-061F000Y193	D-41.2
70-061F000Y283	D-41.2
745016	D-371
85T4-0-2	D-2
85T4-1-2	D-2
85T4-1-27	D-2
85T4-1-106	D-2
85T4-2-2	D-2
85T4-2-4	D-2
85T4-2-10	D-2
85T4-2-27	D-2
85T4-2-60	D-2
85T4-2-108	D-2
85T4-2-116	D-2
85T4-3-1	D-2

PART NUMBER	FIGURE NO.
85T4-3-2	D-2
85T4-3-6	D-2
85T4-3-56	D-2
85T4-4-4	D-2
85T4-4-8	D-2
85T4-4-24	D-2
85T4-4-34	D-2
85T4-4-48	D-2
85T4-4-50	D-2
85T4-5-2	D-2
85T4-5-15	D-2
85T4-6-2	D-2
85T4-6-4	D-2
85T4-6-16	D-2
85T4-7-2	D-2
85T4-7-4	D-2
85T4-8-1	D-2
85T4-8-2	D-2
85T4-8-6	D-2
85T4-9-3	D-2
85T4-10-1	D-2
85T4-10-2	D-2
85T4-10-12	D-2
85T4-11-3	D-2
85T4-11-4	D-2
85T4-12-1	D-2
85T4-12-2	D-2
85T4-14-1	D-2
85T4-16-6	D-2
85T4-375-2	D-2
85T4-375-3	D-2
85T4-375-8	D-2
85T4-375-12	D-2
85T4-375-46	D-2
85T4-375-52	D-2
85T4-500-2	D-2
85T4-500-4	D-2
85T4-500-6	D-2
85T4-625-2	D-2
85T4-875-56	D-2
85T4-1000-8	D-2
85T4-1250-48	D-2
8531 804	D-364.1
8531 834	D-364.1
90-045-5	D-243
90-047-1	D-244
9524491	D-222
99C29	D-70
99C30	D-42

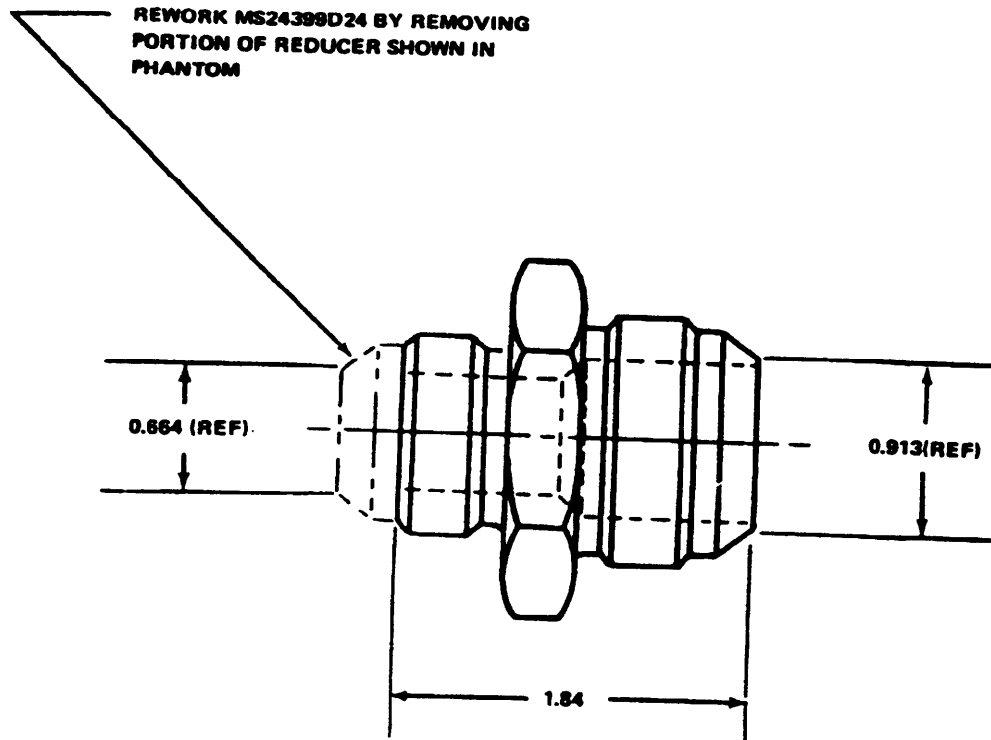
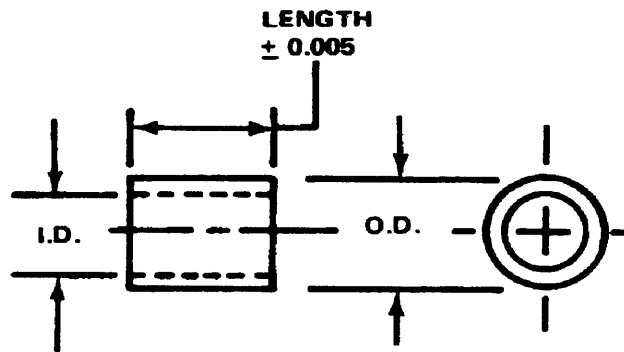


Figure D-1. Part Number 204-060-045-1, FITTING, Reducer Engine Oil Inlet  
Fabricate From NSN 4730-00-684-7446



PART NUMBER	NOMENCLATURE	FABRICATE FROM NSN	ID	OD	LG
NAS42DD4-16	SPACER, RIVET	5340-00-631-3905	0.127	0.260	0.250
NAS42DD6-8	SPACER, SLEEVE	5340-00-631-3904	0.190	0.385	0.125
NAS43-3-8	SPACER, SCREW AND BOLT	5340-00-826-6257	0.194	0.322	0.125
NAS43-3-24	SPACER, SCREW AND BOLT	5340-00-826-6257	0.194	0.322	0.375
NAS43-3-42	SPACER, SCREW AND BOLT	5340-00-826-6257	0.194	0.322	0.656
NAS43-3-48	SPACER, SCREW AND BOLT	5340-00-826-6257	0.194	0.322	0.750
NAS43-4-12	SPACER, SCREW AND BOLT	5340-00-632-1254	0.256	0.365	0.187
NAS43-4-14	SPACER, SCREW AND BOLT	5340-00-632-1254	0.256	0.365	0.218
NAS43-4-44	SPACER, SCREW AND BOLT	9535-00-167-2151	0.256	0.365	0.687
NAD43-4-108	SPACER, SCREW AND BOLT	5340-00-632-1254	0.256	0.365	1.687
NAS43-5-36	SPACER, SCREW AND BOLT	5340-00-632-1252	0.320	0.448	0.582
NAS43-5-48	SPACER, SCREW AND BOLT	5340-00-632-1252	0.320	0.448	0.750
NAS43-6-12	SPACER, SCREW AND BOLT	5340-00-540-3668	0.377	0.515	0.187
NAS43-6-30	SPACER, SCREW AND BOLT	5340-00-540-3668	0.377	0.515	0.468
NAS43DD1-16	SPACER, SLEEVE	5340-00-841-8565	0.143	0.260	0.250
NAS43DD1-7	SPACER, SLEEVE	5340-00-632-3562	0.143	0.260	0.114
NAS43DD3-9	SPACER, SCREW AND BOLT	5340-00-727-1891	0.194	0.322	0.140
NAS43DD3-10	SPACER, SCREW AND BOLT	5340-00-727-1891	0.194	0.322	0.186
NAS43DD3-12	SPACER, SCREW AND BOLT	5340-00-727-1891	0.194	0.322	0.187
NAS43DD3-19	SPACER, SLEEVE	5340-00-727-1891	0.194	0.322	0.206
NAS43DD3-21	SPACER, SCREW AND BOLT	5340-00-727-1891	0.194	0.322	0.328
NAS43DD3-22	SPACER, SCREW AND BOLT	5340-00-727-1891	0.194	0.322	0.343
NAS43DD3-23	SPACER, SCREW AND BOLT	5340-00-727-1891	0.194	0.322	0.359
NAS43DD3-28	SPACER, SCREW AND BOLT	5340-00-727-1891	0.194	0.322	0.437
NAS43DD3-30	SPACER, SCREW AND BOLT	5340-00-727-1891	0.194	0.322	0.468
NAS43DD3-31	SPACER, SCREW AND BOLT	5340-00-727-1891	0.194	0.322	0.484

Figure D-2. (Sheet 1 of 4)

PART NUMBER	NOMENCLATURE	FABRICATE FROM NSN	ID(I)	OD (1)	LG
NAS43DD3-36	SPACER, SCREW AND BOLT	5340-00-727-1891	*0.194	*0.322	0.562
NAS43DD3-38	SPACER, SCREW AND BOLT	5340-00-727-1891	*0.194	*0.322	0.593
NAS43DD3-44	SPACER, SCREW AND BOLT	5340-00-727-1891	*0.194	*0.322	0.687
NAS43DD3-45	SPACER, SCREW AND BOLT	5340-00-727-1891	*0.194	*0.322	0.703
NAS43DD3-48	SPACER, SCREW AND BOLT	5340-00-727-1891	*0.194	*0.322	0.750
NAD43DD3-50	SPACER, SCREW AND BOLT	5340-00-727-1891	*0.194	*0.322	0.781
NAS43DD3-53	SPACER, SCREW AND BOLT	5340-00-727-1891	*0.194	*0.322	0.828
NAS43DD3-54	SPACER, SCREW AND BOLT	5340-00-727-1891	*0.194	*0.322	0.843
NAS43DD3-64	SPACER, SCREW AND BOLT	5340-00-727-1891	*0.194	*0.322	1.000
NAS43DD3-65	SPACER, SCREW AND BOLT	5340-00-727-1891	*0.194	*0.322	1.015
NAS43DD3-67	SPACER, SCREW AND BOLT	5340-00-727-1891	*0.194	*0.322	1.046
NAS43DD3-70	SPACER, SCREW AND BOLT	5340-00-727-1981	*0.194	*0.322	1.093
NAS43DD3-74	SPACER, SCREW AND BOLT	5340-00-727-1891	*0.194	*0.322	1.156
NAS43DD3-76	SPACER, SCREW AND BOLT	5340-00-727-1891	*0.194	*0.322	1.187
NAS43DD3-80	SPACER, SCREW AND BOLT	5340-00-727-1891	*0.194	*0.322	1.250
NAS43DD3-88	SPACER, SCREW AND BOLT	5340-00-727-1891	*0.194	*0.322	1.375
NAS43DD3-92	SPACER, SCREW AND BOLT	5340-00-727-1891	*0.194	*0.322	1.437
NAS43DD3-96	SPACER, SCREW AND BOLT	5340-00-727-1891	*0.194	*0.322	1.500
NAS43DD3-98	SPACER, SCREW AND BOLT	5340-00-727-1891	*0.194	*0.322	1.531
NAS43DD3-112	SPACER, SCREW AND BOLT	5340-00-727-1891	*0.194	*0.322	1.750
NAS43DD4-10	SPACER, SCREW AND BOLT	5340-00-632-1254	*0.256	*0.385	0.156
NAS43DD4-16	SPACER, SCREW AND BOLT	5340-00-632-1254	*0.256	*0.385	0.250
NAS43DD4-23	SPACER, SCREW AND BOLT	5340-00-632-1254	*0.256	*0.385	0.359
NAS43DD4-28	SPACER, SCREW AND BOLT	5340-00-632-1254	*0.256	*0.385	0.437
NAS43DD4-38	SPACER, SCREW AND BOLT	5340-00-632-1254	*0.256	*0.385	0.594
NAS43DD4-60	SPACER, SCREW AND BOLT	5340-00-632-1254	*0.256	*0.385	0.937
NAS43DD4-61	SPACER, SCREW AND BOLT	5340-00-632-1254	*0.256	*0.385	0.953
NAS43DD4-71	SPACER, SCREW AND BOLT	5340-00-632-1254	*0.256	*0.385	1.109
NAS43DD5-36	SPACER, SCREW AND BOLT	5340-00-632-1255	*0.320	*0.448	0.567
NAS43DD10-14	SPACER, SCREW AND BOLT	5340-00-841-8565	*0.627	*0.765	0.218
NAS43HT1-7	SPACER, SCREW AND BOLT	5340-00-952-2955	*0.143	*0.260	0.109
NAS43HT3-12	SPACER, SCREW AND BOLT	5340-00-826-6257	*0.194	*0.322	0.187
NAS43HT3-82	SPACER, SCREW AND BOLT	5340-00-826-6257	*0.194	*0.322	1.281
NAS43HT4-7	SPACER, SCREW AND BOLT	5340-00-541-9565	*0.256	*0.385	0.109
NAS43HT4-28	SPACER, SCREW AND BOLT	5340-00-632-1254	*0.256	*0.365	0.437
NAS521-16-12	COUPLING, HOSE	4720-00-843-1731	2.000	2.126	3.000
85T4-0-2	TUBE, INSULATING	5970-00-623-8526	0.325	0.371	1.000
85T4-1-2	TUBE, INSULATING	5970-00-879-0525	0.294	0.334	1.000
85T4-1-27	TUBE, INSULATING	5970-00-870-0525	0.289	0.335	13.500
85T4-1-52	TUBE, INSULATING	5970-00-870-0525	0.294	0.334	26.00
85T4-1-106	TUBE, INSULATING	5970-00-870-0525	0.294	0.334	53.00
85T4-2-2	TUBE, INSULATING	5970-00-235-2725	0.258	0.304	1.000
85T4-2-4	TUBE, INSULATING	5970-00-235-2725	0.263	0.303	2.000

(1) Note: All dimensions nominal except as noted by\*

Figure D-2. (Sheet 2 of 4)



PART NUMBER	NOMENCLATURE	FABRICATE FROM NSN	ID	OD	LG
85T4-2-10	TUBE, INSULATING	5970-00-235-2725	0.263	0.303	5.000
85T4-2-27	TUBE, INSULATING	5970-00-235-2725	0.258	0.304	13.500
85T4-2-60	TUBE, INSULATING	5970-00-235-2725	0.258	0.304	30.00
85T4-2-108	TUBE, INSULATING	5970-00-235-2725	0.263	0.304	54.00
85T4-2-116	TUBE, INSULATING	5970-00-235-2725	0.263	0.304	58.00
85T4-3-1	TUBE, INSULATING	5970-00-263-1327	0.229	0.275	500
85T4-3-2	TUBE, INSULATING	5970-00-263-1327	0.229	0.275	1.000
85T4-3-6	TUBE, INSULATING	5970-00-263-1327	0.234	0.275	3.00
85T4-3-12	TUBE, INSULATING	5970-00-263-1327	0.229	0.275	6.00
85T4-3-56	TUBE, INSULATING	5970-00-263-1327	0.229	0.275	28.00
	TUBE, INSULATING				
85T4-4-4	TUBE, INSULATING	5970-00-284-9698	0.208	0.248	2.00
85T4-4-24	TUBE, INSULATING	5970-00-284-9698	0.208	0.248	12.00
85T4-34	TUBE, INSULATING	5970-00-284-9698	0.208	0.248	17.00
85T4-48	TUBE, INSULATING	5970-00-284-9698	0.208	0.248	24.00
85T4-50	TUBE, INSULATING	5970-00-284-9698	0.208	0.248	25.00
85T4-5-2	TUBE, INSULATING	5970-00-263-1325	0.186	0.226	1.000
85T4-5-15	TUBE, INSULATING	5970-00-263-1325	0.186	0.226	7.500
85T4-6-2	TUBE, INSULATING	5970-00-235-2719	0.166	0.206	1.000
85T4-6-4	TUBE, INSULATING	5970-00-235-2719	0.162	0.208	2.000
85T4-6-16	TUBE, INSULATING	5970-00-235-2719	0.166	0.206	8.000
85T4-7-2	TUBE, INSULATING	5970-00-557-6245	0.148	0.188	1.000
85T4-7-4	TUBE, INSULATING	5970-00-557-6245	0.144	0.186	2.000
85T4-8-1	TUBE, INSULATING	5970-00-284-8468	0.133	0.173	0.500
85T4-8-2	TUBE, INSULATING	5970-00-284-8468	0.133	0.173	1.000
85T4-8-6	TUBE, INSULATING	5970-00-284-8468	0.133	0.173	3.000
85T4-9-3	TUBE, INSULATING	5970-00-843-2281	0.114	0.160	1.500
85T4-10-1	TUBE, INSULATING	5970-00-826-9827	0.106	0.138	0.500
85T4-10-14	TUBE, INSULATING	5970-00-826-9827	0.106	0.140	7.000
85T4-4-8	TUBE, INSULATING	5970-00-284-9698	0.208	0.248	4.00
85T4-10-2	TUBE, INSULATING	5970-00-826-9827	0.102	0.138	1.000
85T4-10-12	TUBE, INSULATING	5970-00-826-9827	0.106	0.140	6.000
85T4-11-3	TUBE, INSULATING	5970-00-284-8627	0.095	0.138	1.500
85T4-11-4	TUBE, INSULATING	5970-00-284-8627	0.095	0.138	2.000
85T4-12-1	TUBE, INSULATING	5970-00-557-6244	0.085	0.119	500
85T4-12-2	TUBE, INSULATING	5970-00-557-6244	0.085	0.138	1.000
85T4-14-1	TUBE, INSULATING	5970-00-235-2721	0.066	0.088	0.500
85T4-16-6	TUBE, INSULATING	5970-00-809-9163	0.053	0.085	3.000
85T4-375-2	TUBE, INSULATING	5970-00-235-2728	0.375	0.431	1.000
85T4-375-3	TUBE, INSULATING	5970-00-235-2728	0.375	0.431	1.500
85T4-375-8	TUBE, INSULATING	5970-00-235-2728	0.375	0.431	4.000
85T4-375-12	TUBE, INSULATING	5970-00-235-2728	0.375	0.431	6.000
85T4-375-46	TUBE, INSULATING	5970-00-235-2728	0.375	0.431	23.000
85T4-375-52	TUBE, INSULATING	5970-00-235-2728	0.375	0.419	26.00
85T4-500-2	TUBE, INSULATING	5970-00-557-6254	0.500	0.248	1.000

Figure D-2. (Sheet3 OF 4)

PART NUMBER	NOMENCLATURE	FABRICATE FROM NSN	ID	OD	LG
85T4-500-4	TUBE INSULATING	5970-00-557-6254	0.500	0.556	2.000
85T4-500-6	TUBE, INSULATING	5970-00-557-6254	0.500	0.556	3.000
85T4-625-2	TUBE, INSULATING	5970-00-615-9853	0.625	0.695	1.000
85T4-875-56	TUBE, INSULATING	5970-00-828-1090	0.875	0.955	28.00
85T4-1000-8	TUBE, INSULATING	5970-00-882-5007	1.000	1.060	4.000
85T4-1250-48	TUBE, INSULATING	5970-00-284-8480	1.250	1.340	24.00
204-071-523-1	TUBE, GUARD	4710-00-277-3627	0.652	0.750	9.000
204-071-542-3	TUBE, GUARD	4710-00-279-0917	0.180	0.250	8.500
204-075-181-9	SPACER	9330-00-260-3806	0.250	1.000	0.250

Figure D-2. (Sheet 4 of 4)



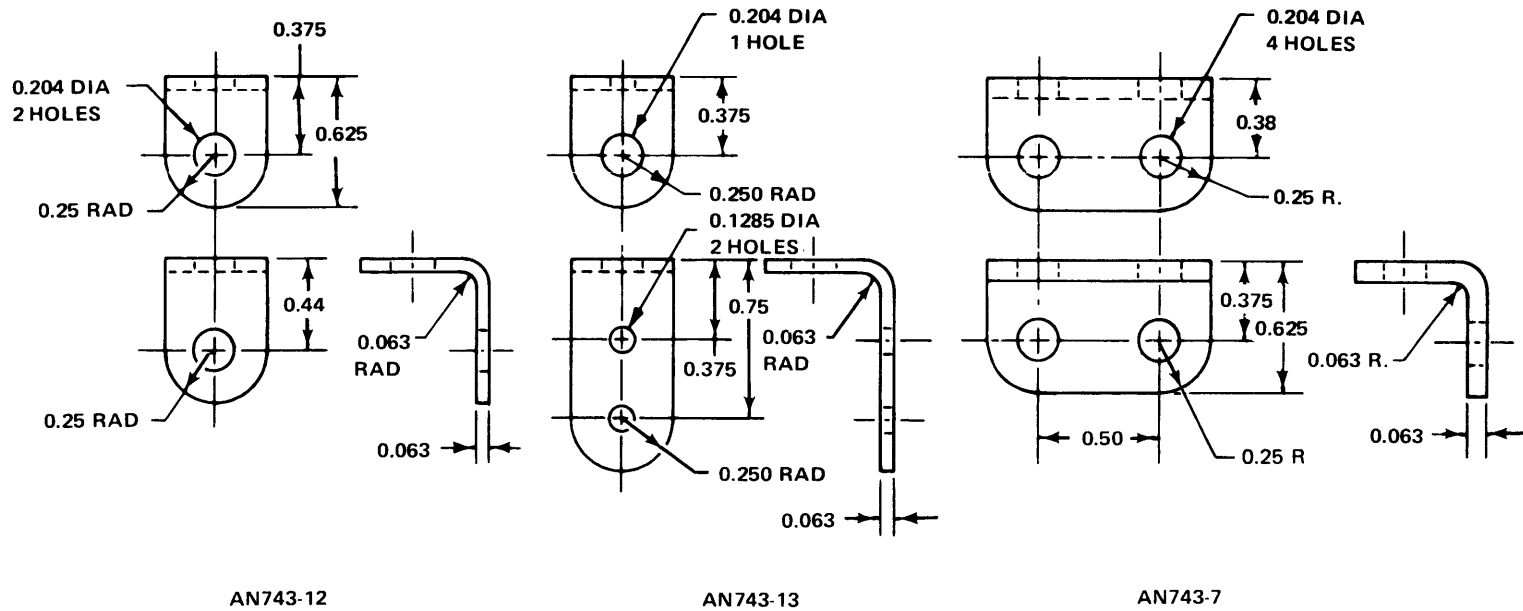


Figure D-4. Part Number

**AN 743-7 BRACKET, Support Clamp**

**AN 743-12**

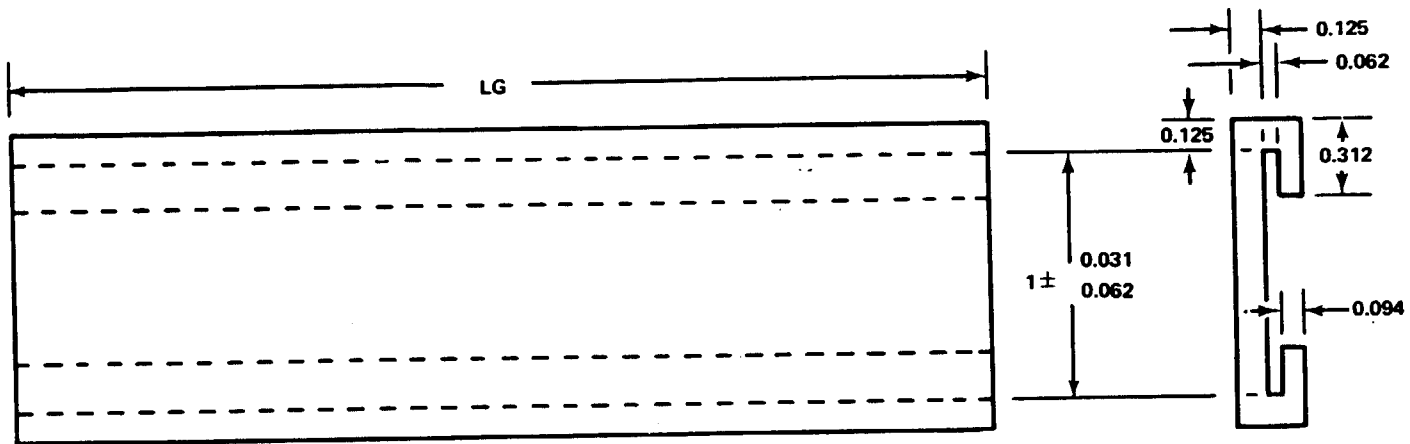
**AN 743-13**

NSN 9535-00-232-0378

**Fabricate from:**

**Material:**

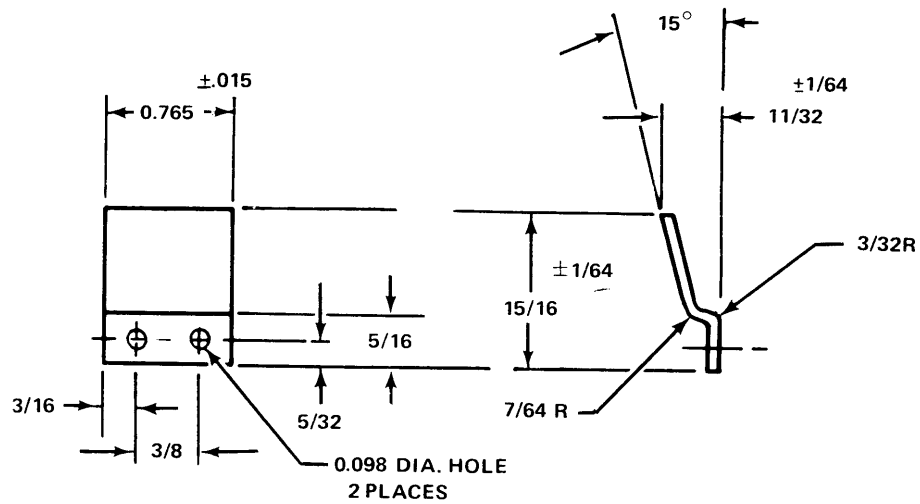
**Federal Specification, QQ-A-362 2024 AL ALY Sheet,  
0.063 Inch Thick**



NOTES  
 1. + 0.125  
 Tolerance on Lg

PARTS NUMBER	FABRICATE FROM NSN	LG
AN8031-8-183	9390-00-263-0061	18.75

**Figure D-5.** Part Number AN 8031-8-183 PAD, Strap  
 Fabricate from: 9390-00-263-0061  
 Material: Synthetic rubber and cork channel MIL-G-6183  
 Synthetic Rubber, Nonmetallic Soft, Fuel and Oil Grade MIL-G-6183



NOTES:

1. MATL. PER SPEC. QQA318
2. FINISH IRIDITE PER SPEC. MIL-C-5541

Figure D-6. Part Number A6544, CLIP, Wire Light  
 Fabricate from: NSN 9535-00-232-0378  
 Material: 2024 AL ALY Sheet, Federal Specification QQ-250/5, 0.063 Inch Thick

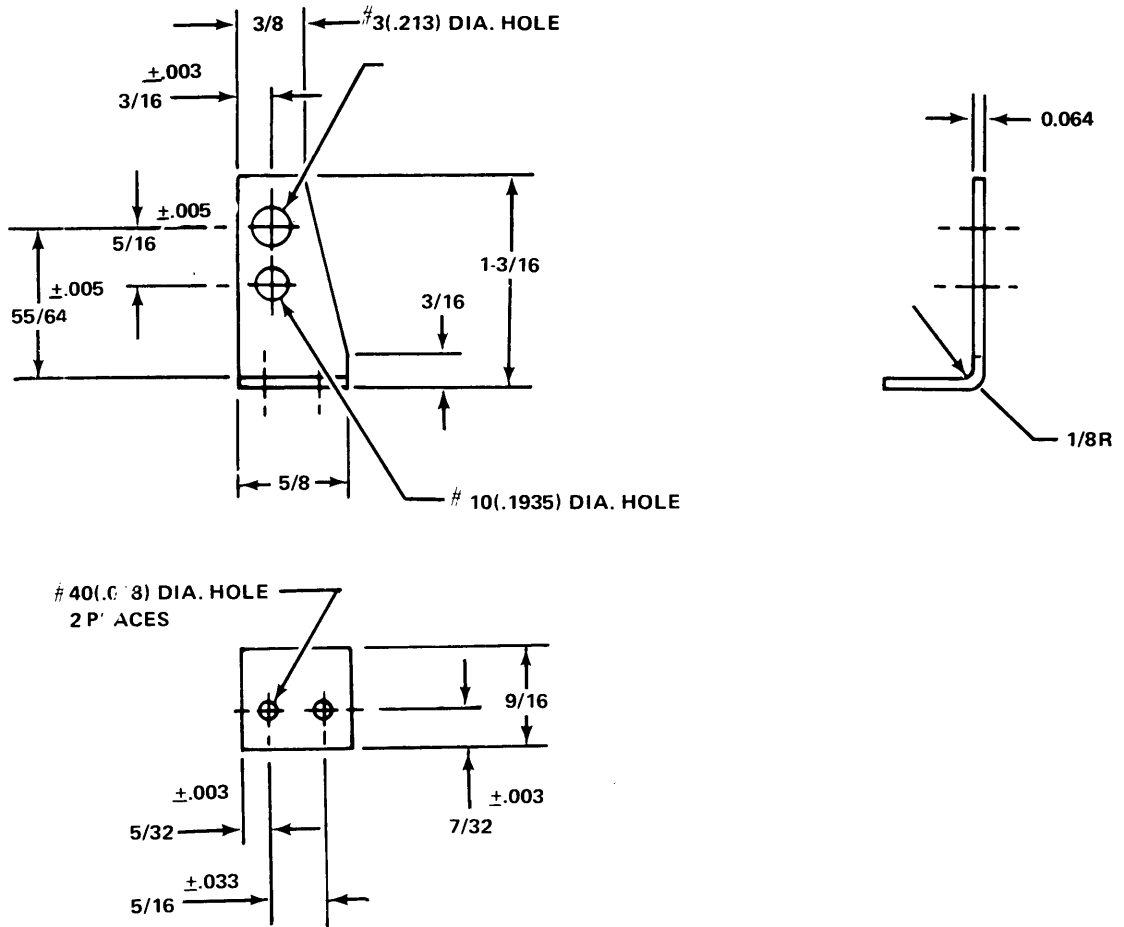
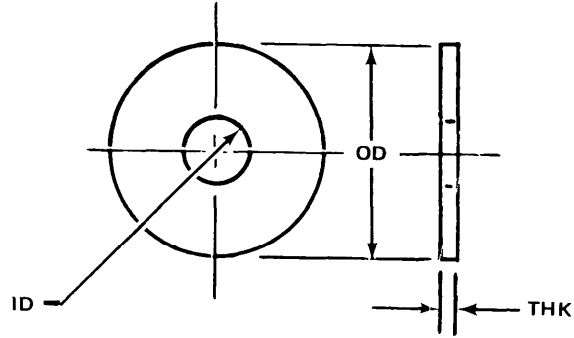


Figure D-7. Part Number A6545, BRACKET, LH  
 Fabricate from: NSN 9535-00-232-0378  
 Material: 2024 AL ALY Sheet, Federal Specification QQ-A-250/5 0.063 Inch Thick



BREAK SHARP EDGES .025 x 45° or .025 R  
 DIAMETERS TO BE CONCENTRIC  
 TO .010 T.I.R.

PART NUMBER	NAME	FABRICATE FROM	ID	OD	THK
204-010-780-1	WASHER	5310-00-167-0766	0.397 0.390	1.125 ± .01	0.063 ± .01
204-010-793-3	WASHER	5310-00-167-0766	0.256 0.263	0.700 ± .01	0.063 ± .01
204-011-708-1	WASHER	5310-00-167-0766	0.457	1.125 ± .01	0.063 ± .01
204-011-708-3	WASHER	5310-00-167-0768	0.452	1.625 ± .01	0.063 ± .01

WASHER, FLAT

Figure D-8.



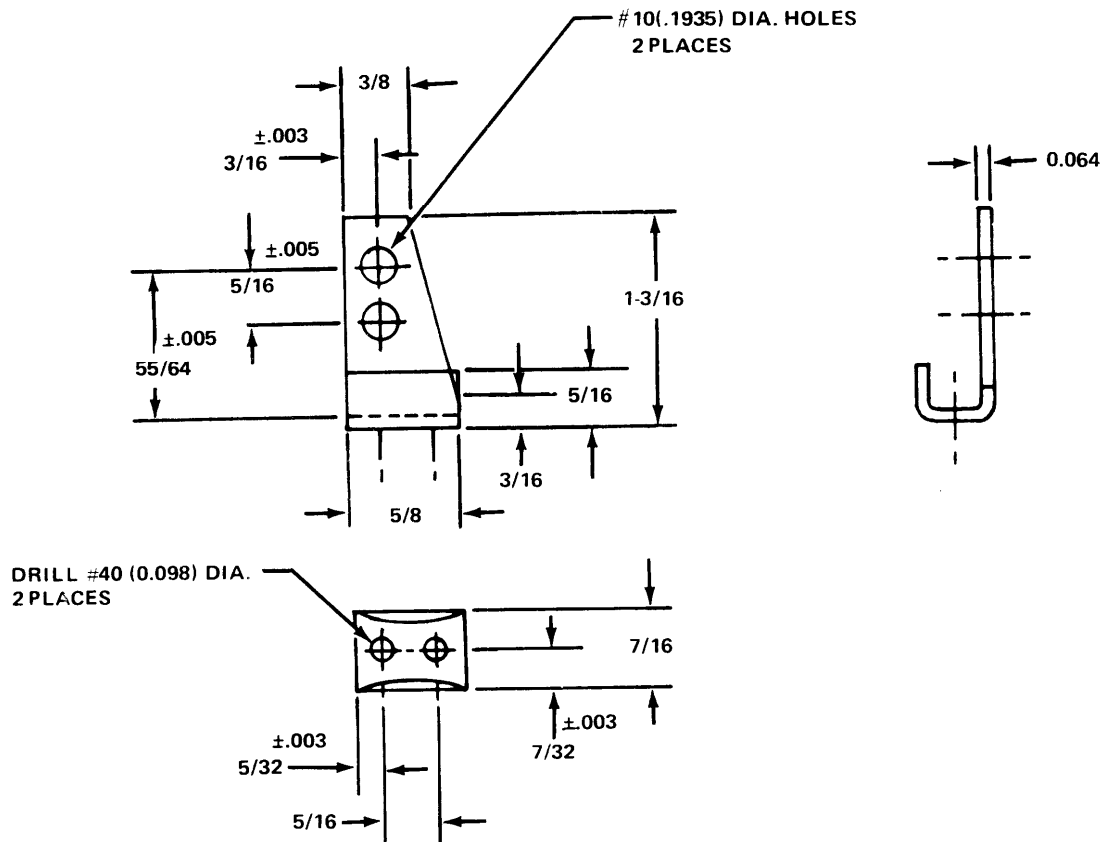


Figure D-9

Part Number: A6546, BRACKET  
 Fabricate from: NSN 9535-00-232-0378  
 Material: 2024 AL ALY Sheet, Federal Specification QQ-A-250/5, 0.063 Inch Thick

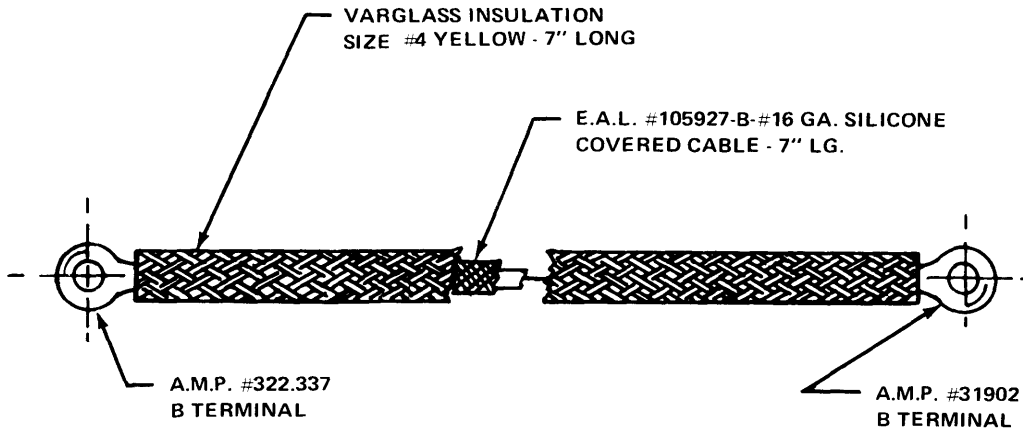


Figure D-10. Part Number A6910, WIRE ASSEMBLY, Lamp  
Fabricate from: NSN 5940-00-557-1627  
NSN 6145-00-998-7609

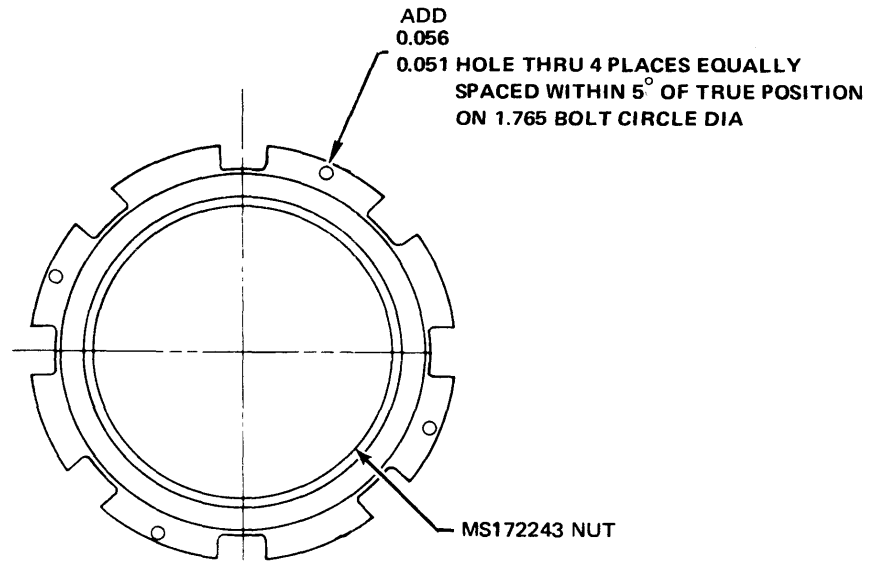


Figure D-11.	Part Number	204-001-222-1 NUT, Collective Stick Lock
	Fabricate from:	NSN 5310-00-566-8864 (MS 172243)
	Material:	Steel AMS 6381 or AMS 6382

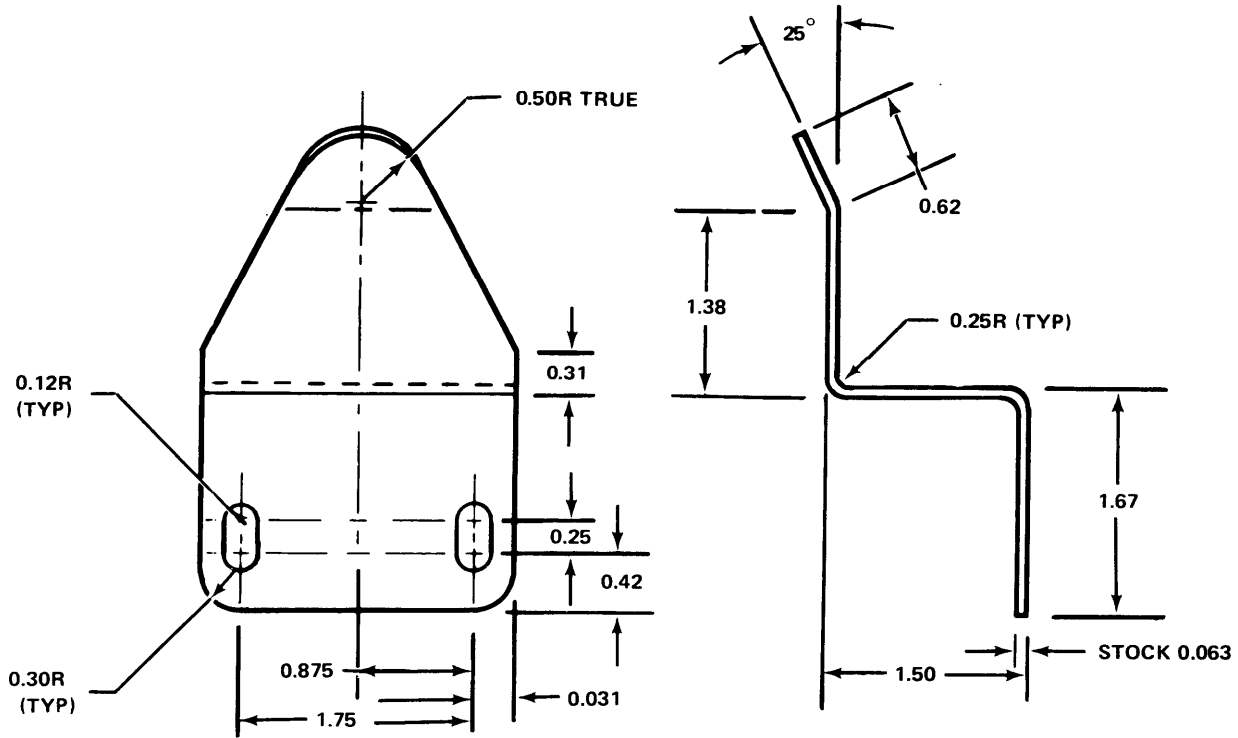


Figure D-12. Part Number 204-030-010-1 STOP, Windshield Wiper  
 Fabricate from: NSN 9535-00-232-0378  
 Material: 2024 AL ALY, Sheet, Federal Specification QQ-A-250/5,  
 0.063 Inch Thick

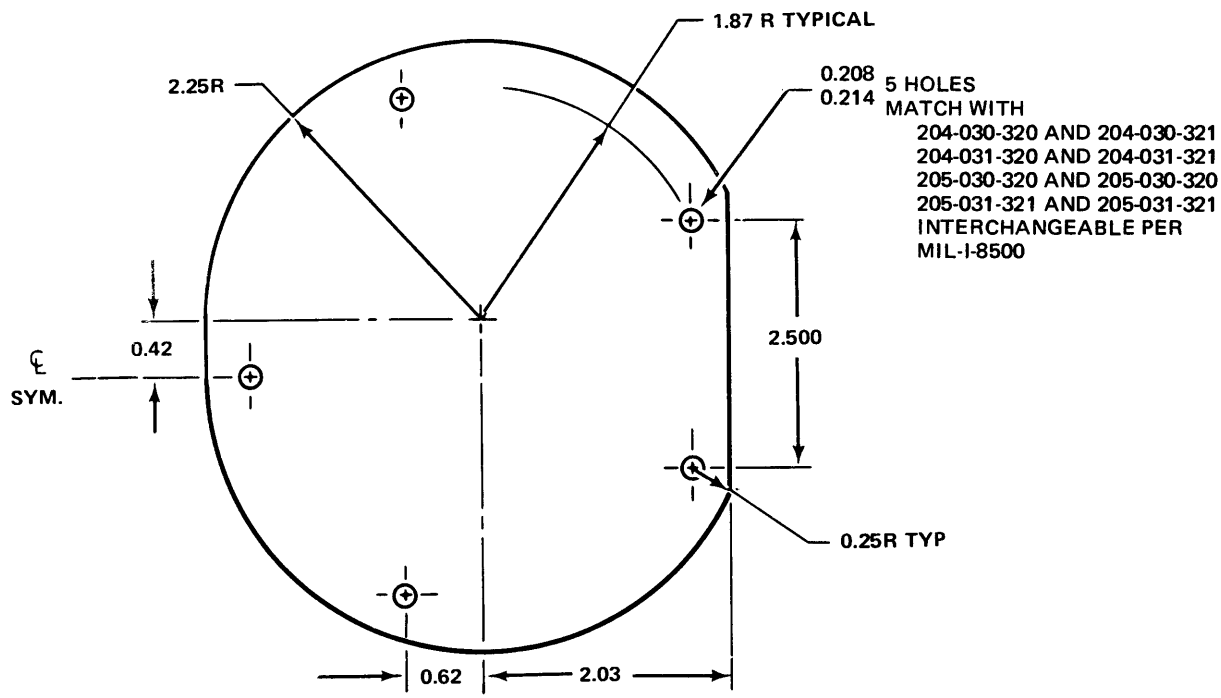
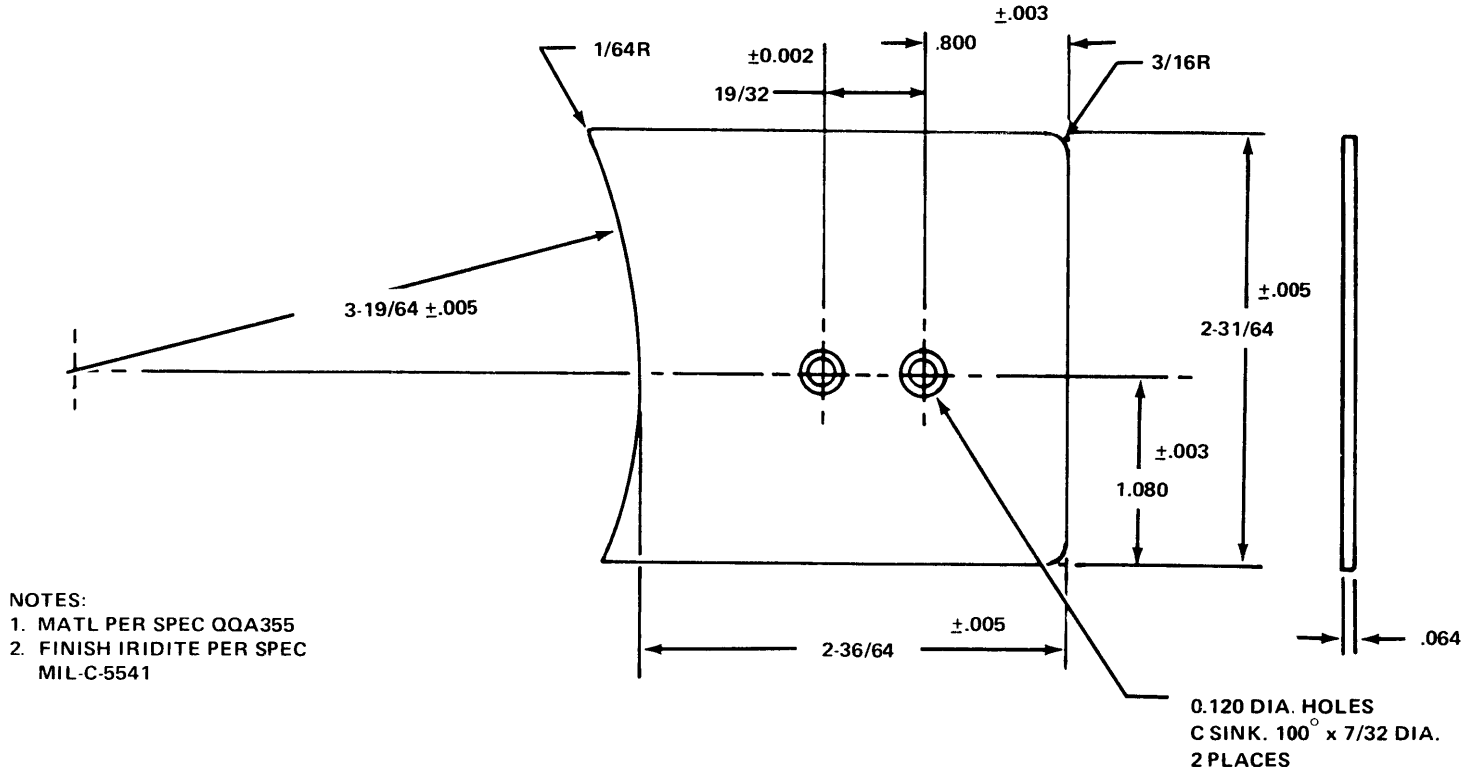
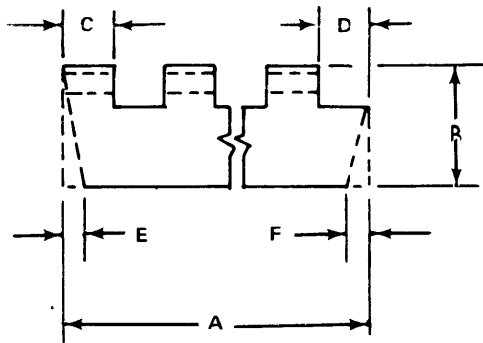


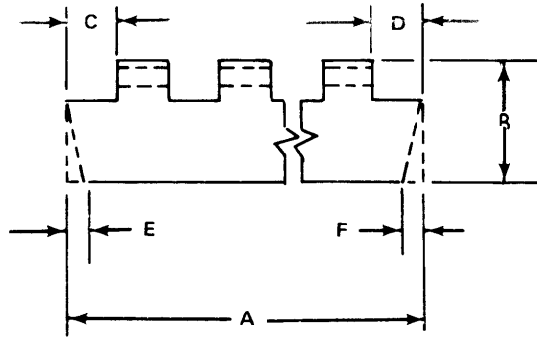
Figure D-13. Part Number 204-030-337-3 DOOR, Cyclic  
 Fabricate from: NSN 9535-00-086-9729  
 Material: 7075 AL ALY, T6, Federal Specification QQ-A-250/13,  
 0.025 Inch Thick



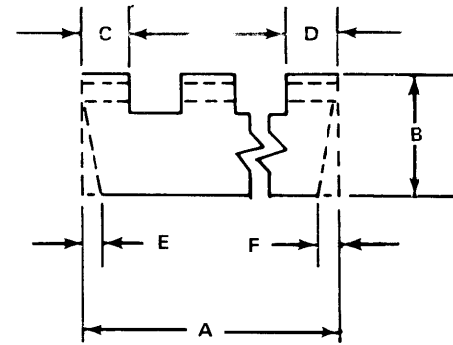
**Figure D-14.** Part Number A6915. PLATE. Cover  
 Fabricate from: NSN 935-00-232-0378  
 Material: 2024 AL ALY Sheet, Federal Specification QQ-A-250/5, 0.63 Inch Thick



TYPE 1

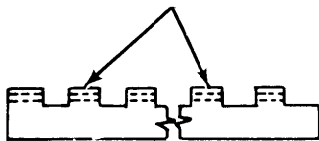


TYPE 2



TYPE 3

REMOVE TANG TWO PLACES



DETAIL A-A

GENERAL NOTES:

1. CRIMP BOTH ENDS OF HINGE TO RETAIN HINGE PIN.
2. HOLES TO BE DRILLED AT TIME OF INSTALLATION AND TO BE EQUALLY SPACED ALONG HINGE HALF.

SPECIAL NOTES:

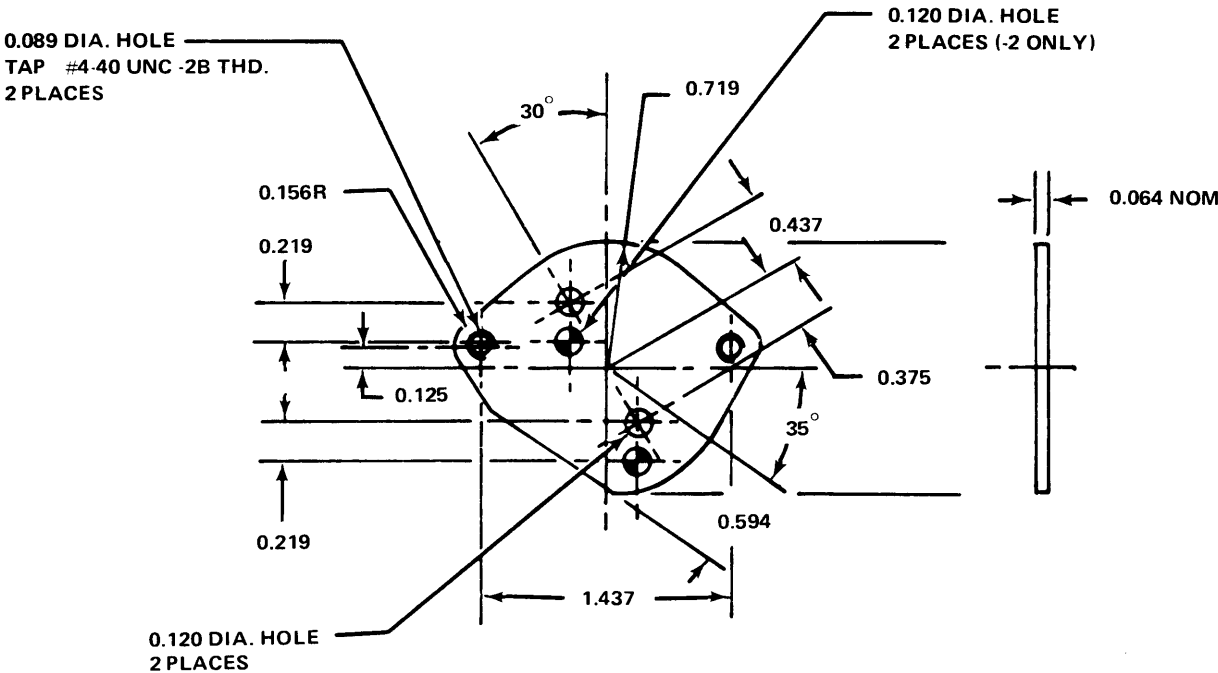
- A. FOR INSTALLATION OF SPRING REMOVE CENTER TANG.
- B. FOR INSTALLATION OF SPRINGS REMOVE TWO TANGS. SEE DETAIL A-A.
- C. HINGE HALF WITH TANGS REMOVED MAY BE MISMATCHED AT BOTTOM OF TANG.
- D. BOTH ENDS OF HINGE HALF MUST BE EQUAL WITHIN 0.020 INCHES.

Figure D-15. (Sheet 1 of 2)

PART NUMBER	FABRICATE FROM NSN	TYPE	A	B	C	D	E	F	NO. OF HOLES TO BE DRILLED	SPECIAL NOTES
AN257-2-650	5340-00-664-8121	1	6.50	STOCK			N/A	N/A	AR	D
204-030-831-21	5340-00-993-1461	1	AR	STOCK			N/A	N/A	AR	D
204-030-813-23	5340-00-993-1461	1	AR	STOCK			N/A	N/A	AR	D
204-030-813-25	5340-00-993-1461	1	AR	STOCK			N/A	N/A	AR	D
204-030-813-27	5340-00-993-1461	1	AR	STOCK			N/A	N/A	AR	D
204-030-840-1	5340-00-993-1461	1	14.50	STOCK			N/A	N/A	AR	D
204-030-840-3	5340-00-993-1461	2	7.16	STOCK			N/A	N/A	AR	D
204-030-840-5	5340-00-993-1461	2	7.16	STOCK			N/A	N/A	AR	D
205-030-245-13	5340-00-664-8140	1	6.30	STOCK			N/A	N/A	6	D
205-030-245-53	5340-00-664-8140	1	6.30	STOCK			N/A	N/A	6	B,D
205-030-245-43	5340-00-664-8140	1	6.30	STOCK			N/A	N/A	6	B,D
205-030-245-45	5340-00-664-8140	1	6.30	STOCK			N/A	N/A	6	D
205-030-484-15	5340-00-664-8140	3	3.10	STOCK			N/A	N/A	5	D
205-030-484-17	5340-00-664-8140	2	3.10	STOCK			N/A	N/A	5	D
205-030-539-11	5340-00-664-8140	1	2.50	STOCK			N/A	N/A	4	D
205-031-668-51	5340-00-993-1461	1	6.00	STOCK			N/A	N/A	6	D

Figure D-15. (Sheet 2 of 2)





- NOTES:
- 1. MATL: 5052-H32 AL PER SPEC QQ-A-318
  - 2. FINISH: IRIDITE PER SPEC. MIL-C-5541
  - 3. THREADS PER SPEC MIL-S-7742

Figure D-16. Part Number A9116-2 PLATE  
Fabricate from: NSN 9535-00-232-0378  
Material: 2024 AL ALY Sheet, Federal Specification, QQ-A-250/5, 0.063 Inch Thick

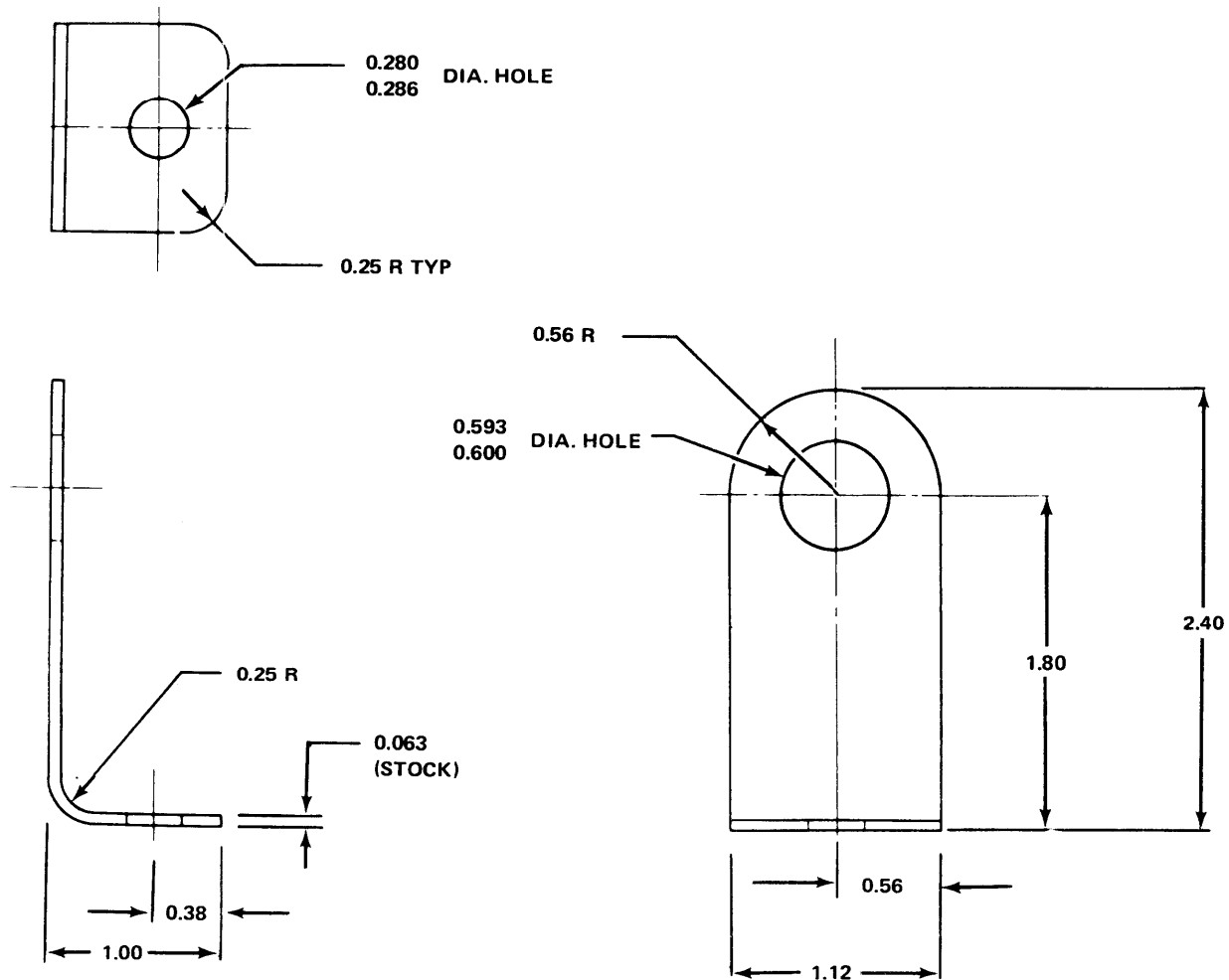
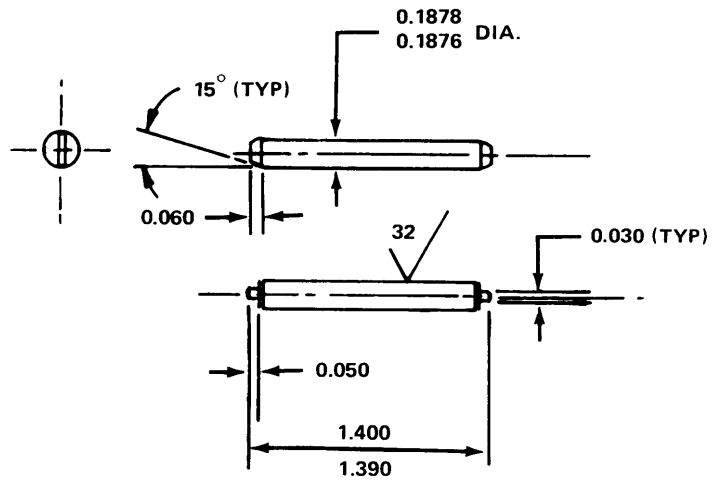


Figure D-17. Part Number 204-040-299-1 BRACKET, Oil Drain Line  
 Fabricate from: NSN 9535-00-232-0378  
 Material: 2024 AL ALY Sheet, Federal Specification QQ-A-250/5, 0.063 Inch Thick

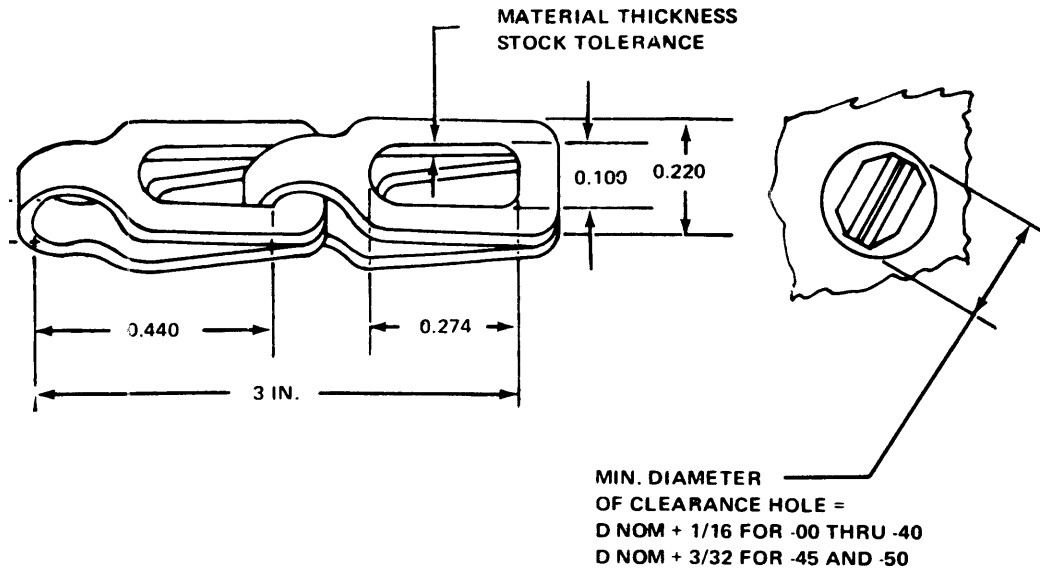


NOTE:

1. COAT WITH PRESERVATIVE OIL AND WRAP IN MOISTURE-PROOF PAPER (OR EQ.)

Figure D-18.

Part Number CSC536-3, PIN, Cam  
 Fabricate from: NSN 9510-00-234-7620

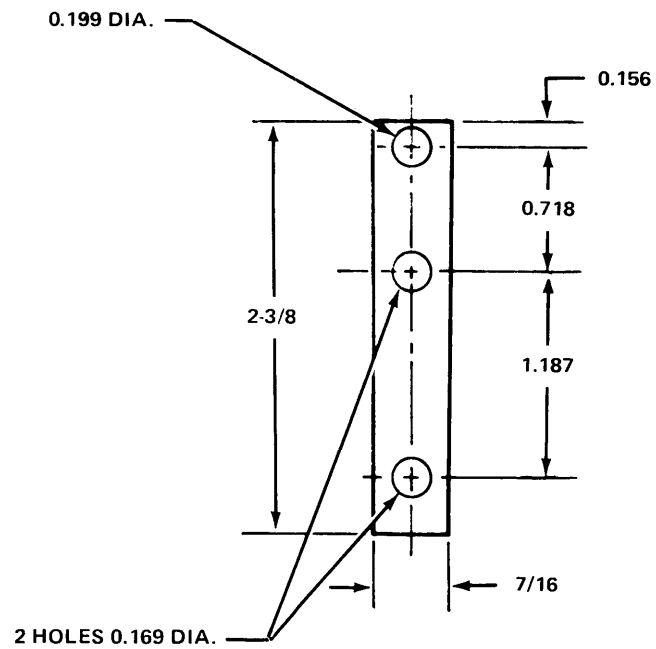


PART NUMBER	FABRICATE FROM NSN	A	B	C	D	E	LG
NAS 1455-00-3C	4010-00-262-1551	0.440	0.274	0.100	0.220	0.120	3 IN.
NAS 1455-00-5	4010-00-228-9948	0.440	0.274	0.100	0.220	0.120	5 IN.
NAS 1455-1A2-5	4010-00-554-8661	0.576	0.350	0.109	0.178	0.295	5 IN.
NAS 1455-B00-5	4010-00-554-8661	0.440	0.274	0.100	0.220	0.120	5 IN.
NAS 1455-A-00-4	4010-00-262-1551	0.440	0.274	0.100	0.220	0.120	4 IN.
1560-UH1-762-2	4010-00-554-8661	0.440	0.274	0.100	0.220	0.120	6 IN.
1560-UH1-762-2 *	5315-00-194-2455	0.440	0.274	0.100	0.220	0.120	6 IN.

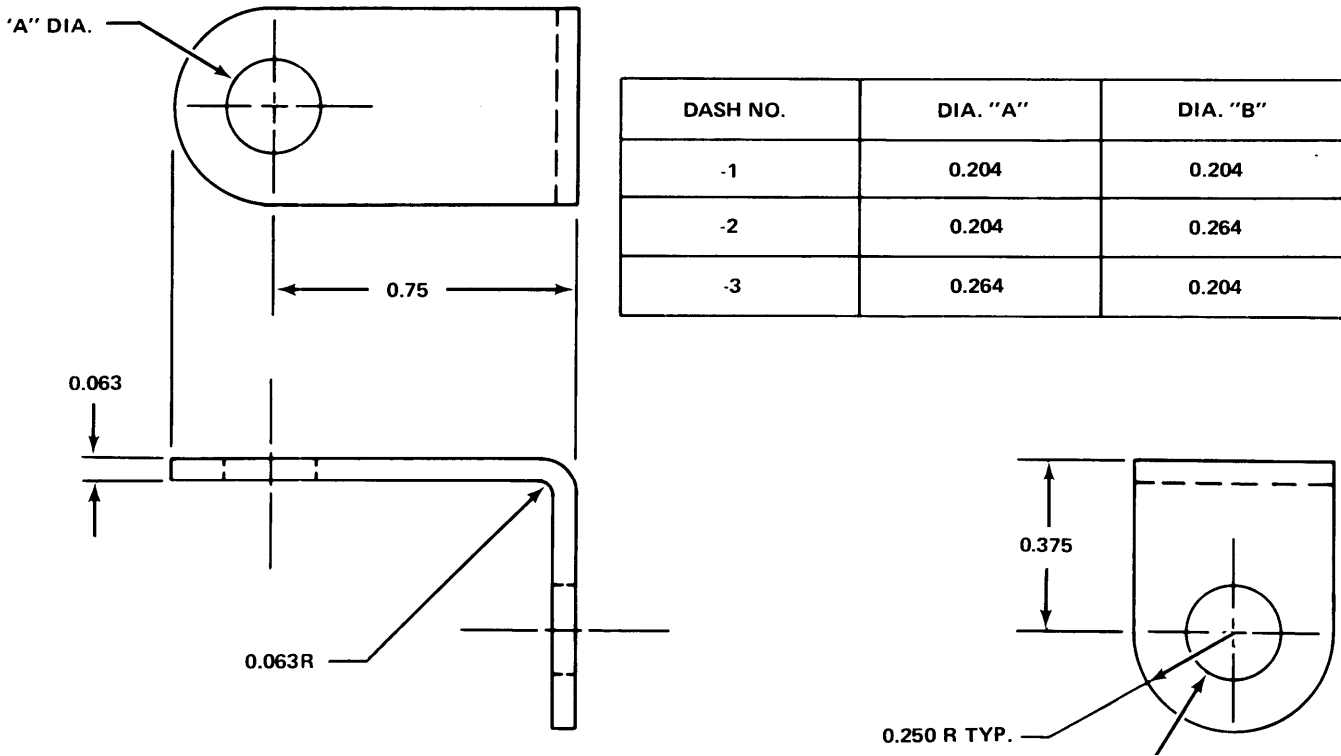
CHAIN, WELDLESS

\* Use with P/N 1560-UH1-762-2 only

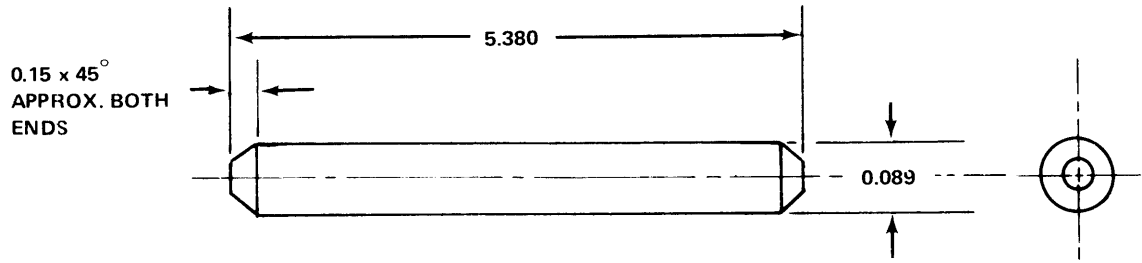
Figure D-19.



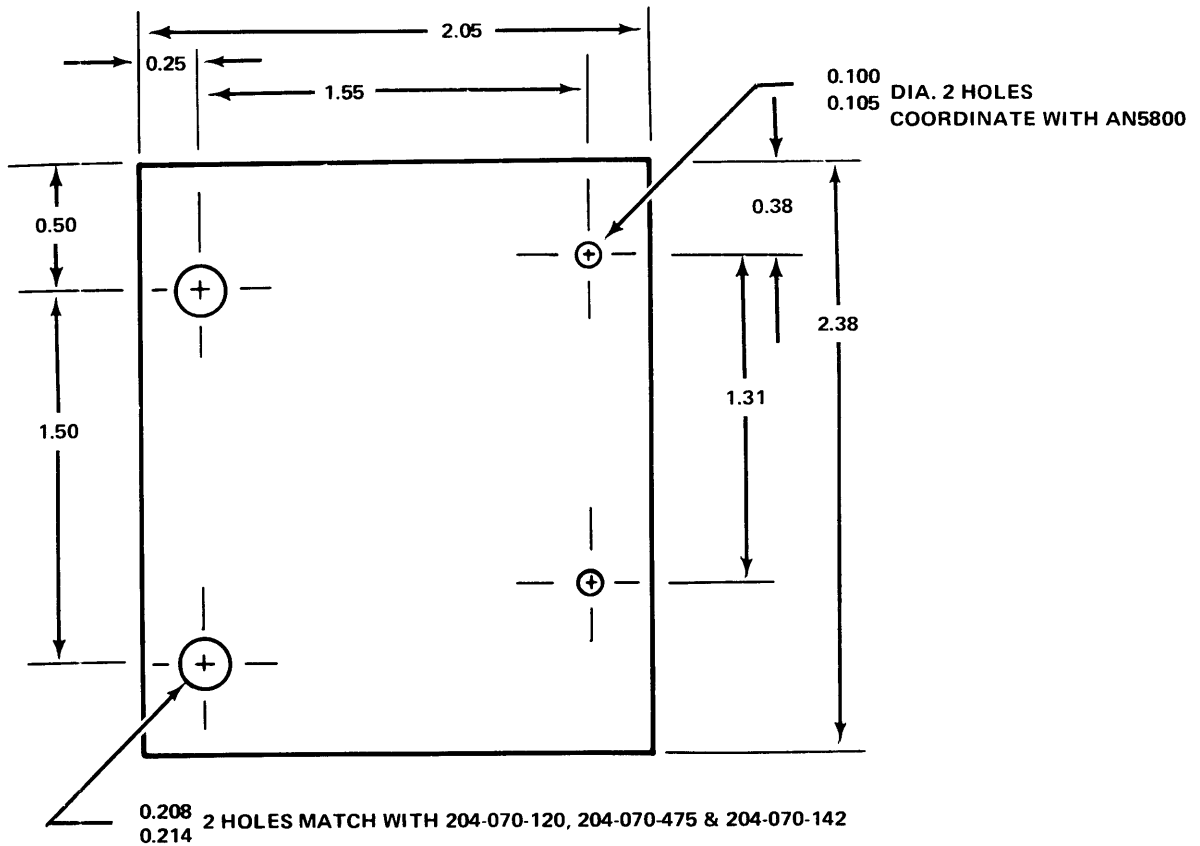
**Figure D-20.** Part Number W20396, BRACKET  
 Fabricate from: NSN 9535-00-640-2311  
 Material: 2024 AL ALY Sheet, Federal Specification, QQ-A-250/5, 0.050 Inch Thick



**Figure D-21.** Part Numbers 20-032-1 BRACKET SUPPORT  
 20-032-2  
 20-032-3  
 Fabricate from: NSN 9535-00-232-0378  
 Material 2024 AL ALY Sheet, Federal Specification, QQ-A-250/5, 0.063 Inch Thick



**Figure D-22.** Part Number: MS20253P2-538 PIN, HINGE  
 Fabricate from: NSN 5340-00-043-3723  
 Material: Rod, Straight, Headless Cres. Cadmium Plated. 0.089 Inch Diameter



**Figure D-23.** Part Number: 204-070-143-3 PLATE, Correction Card Holder  
 Fabricate from: NSN 9535-00-167-2277  
 Material: 2024 AL ALY Sheet, Federal Specification, QQ-A-250/5, 0.020 Inch Thick

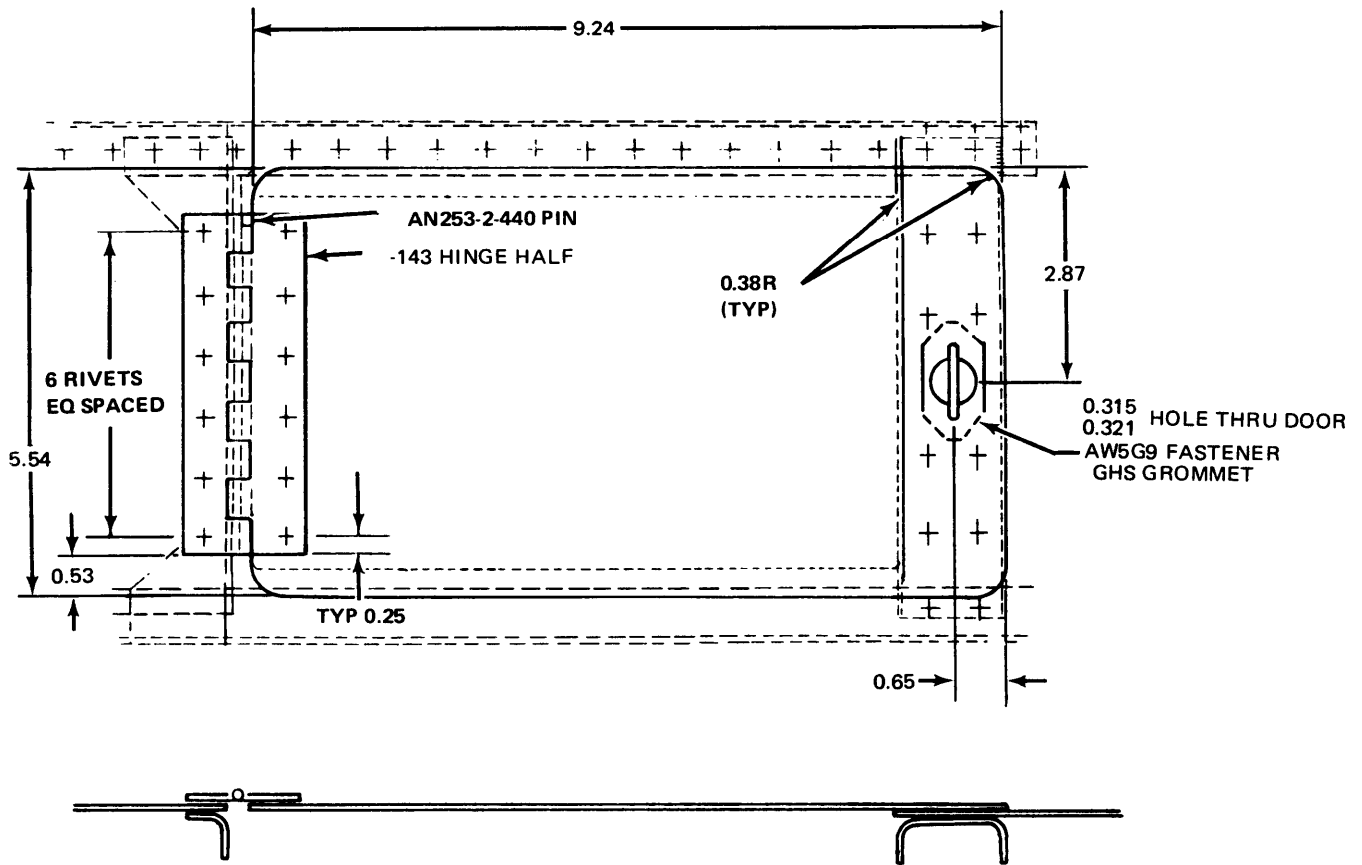


Figure D-24. Part Number 204-030-007-139 DOOR ASSEMBLY  
 Fabricate from: NSN 9535-00-167-2279  
 NSN 5340-00-209-7519  
 NSN 5325-00-838-8804  
 NSN 5325-00-141-4002  
 Material: 2024 AL ALY, Federal Specification, QQ-A-25, 0.020 Inch Thick

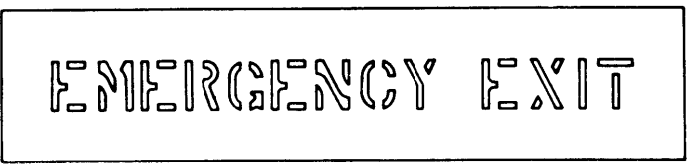


TUBE ASSY PART NUMBER	FABRICATE FROM NSN	STOCK DIM.	END FITTING												
			NUT NSN	NO. REQ.	SLEEVE NSN	NO. REQ.									
204-040-749-1	4710-00-279-0955	3/8 x 0.035 x 30.00	4730-00-142-2167	1	4730-00-278-6070	1									
1ST BEND FROM "Y"				2ND BEND FROM "Y"				3RD BEND FROM "Y"				4TH BEND FROM "Y"			
DIST FROM "Y" END	RAD.	BEND DEG.	DIAL ROT CW	DIST. FROM "Y" END	RAD.	BEND DEG.	DIAL ROT CW	DIST FROM "Y" END	RAD.	BEND DEG.	DIAL RTN CW	DIAL FROM "Y" END	RAD.	BEND DEG.	DIAL RTN CW
1.00	0.094	90	0	3.50	0.094	19	270	4.87	0.094	90	270	7.75	0.094	135	135
5TH BEND FROM "Y"				6TH BEND FROM "Y"											
12.50	0.094	90	180	22.00	0.094	35	0								
TUBE ASSY PART NUMBER	FABRICATE FROM NSN	STOCK DIM.	END FITTING												
			NUT NSN	NO. REQ.	SLEEVE NSN	NO. REQ.									
204-060-020-207	4710-00-278-6398	1/4 x 0.028 x 46.00	4730-00-278-0289	1	4730-00-302-8641	1									
1ST BEND			2ND BEND				3RD BEND				4TH BEND				
DIST A	RAD.	BEND DEG.	DIST A	RAD.	TURN ANG.	BEND DEG.	DIST A	RAD.	TURN ANG.	BEND DEG.	DIST A	RAD.	TURN ANG.	BEND DEG.	
44.75	0.56	82	40.25	0.56	175R	58	30.00	0.56	5R	25	20.75	0.56	0	22	
5TH BEND			6TH BEND												
11	0.56	5R	35	2.62	0.56	180	55								

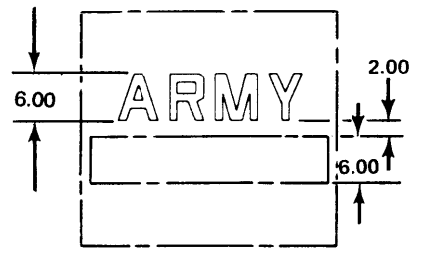
Figure D-25.



A



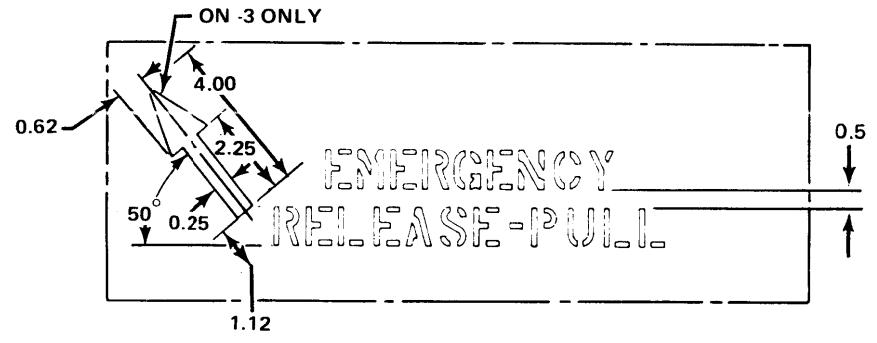
B



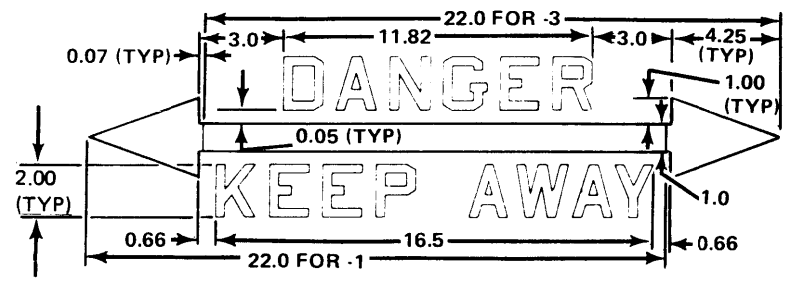
C



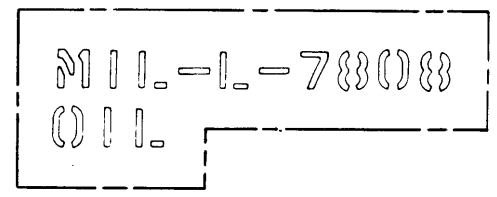
D



E



F



G

Figure D-26. (Sheet 1 of 3)

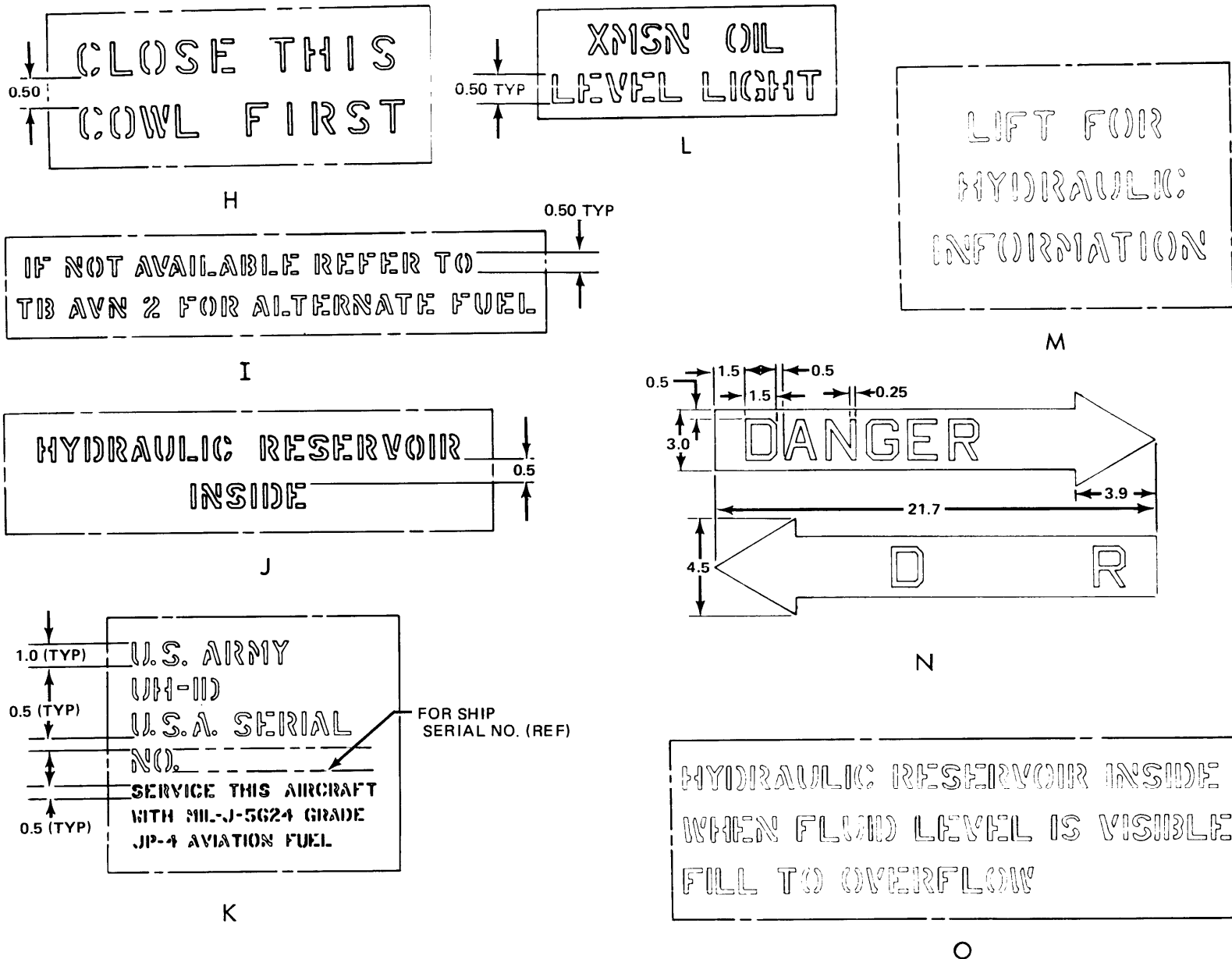
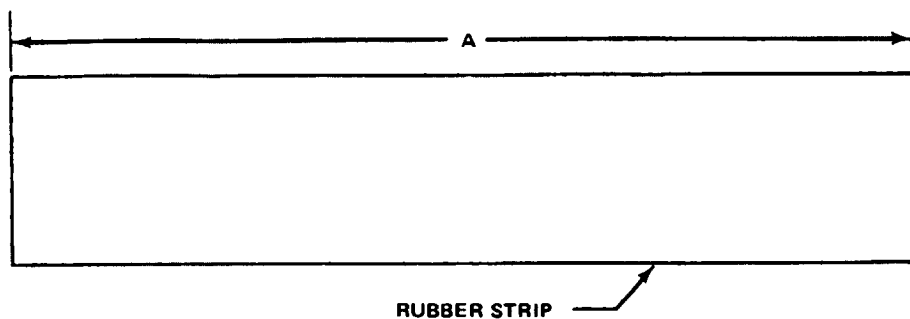


Figure D-26. (Sheet 2 of 3)

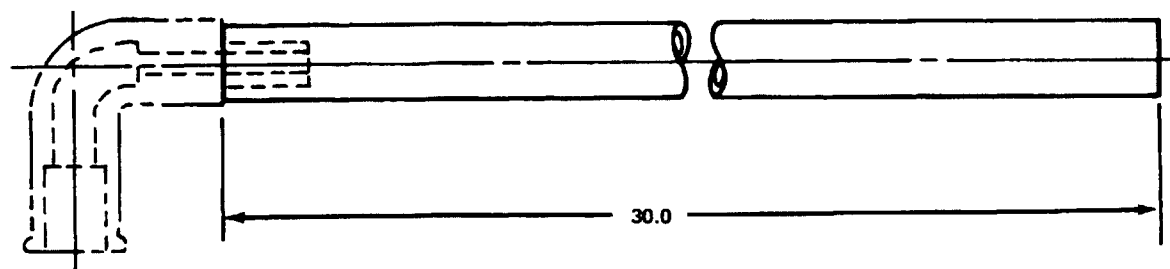
PART NUMBER	FABRICATE FROM NSN	REF LETTER	NOTES:
204-040-671-1	9310-00-265-6797	A	LETTERS TO BE 0.50 IN. HIGH, SPACED APPROX AS SHN
204-070-343-1	9310-00-265-6797	B	LETTERS TO BE 1.00 IN. HIGH, SPACED APPROX AS SHN ;
204-070-794-1	9310-00-265-6797	C	LETTERS TO BE 6.00 IN. HIGH, SPACED APPROX AS SHN
204-070-798-1	9310-00-265-6797	D	LETTERS TO BE 0.50 IN. HIGH, SPACED APPROX AS SHN SHN
204-070-812-3	9310-00-265-6797	E	LETTERS TO BE 1.00 IN. HIGH, SPACED APPROX AS SHN SHN
204-070-818-1	9310-00-265-6797	F	
204-070-818-3	9310-00-265-6797	F	
205-040-164-1	9310-00-265-6797	G	
205-070-226-1	9310-00-265-6797	H	LETTERS TO BE 0.50 IN. HIGH, SPACED APPROX AS SHN
205-070-801-1	9310-00-265-6797	I	LETTERS TO BE 0.50 IN. HIGH, SPACED APPROX AS SHN
205-070-810-1	9310-00-265-6797	J	LETTERS TO BE 0.50 IN. HIGH, SPACED APPROX AS SHN
205-070-829-1	9310-00-265-6797	K	
205-070-840-1	9310-00-265-6797	L	LETTERS TO BE 0.50 IN. HIGH, SPACED APPROX AS SHN
205-070-850-1	9310-00-265-6797	M	LETTERS TO BE 0.50 IN. HIGH, SPACED APPROX AS SHN
205-070-853-1	9310-00-265-6797	N	
205-070-853-3	9310-00-265-6797	N	
205-070-859-1	9310-00-265-6797	O	LETTERS TO BE 0.50 IN. HIGH, SPACED APPROX AS SHN

Figure D-26. (Sheet 3 of 3)



PART NUMBER	NOMENCLATURE	FABRICATE FROM NSN	A
204-030-853-73	RUBBER STRIP	9320-00-880-4520	50.000
204-030-853-83	RUBBER STRIP	9320-00-880-4520	53.500
204-030-853-85	RUBBER STRIP	9320-00-880-4520	22.000
204-030-853-111	RUBBER STRIP	9320-00-880-4520	3.000
204-030-853-113	RUBBER STRIP	9320-00-880-4520	8.300
204-030-853-115	RUBBER STRIP	9320-00-880-4520	7.700
204-030-853-117	RUBBER STRIP	9320-00-880-4520	18.500

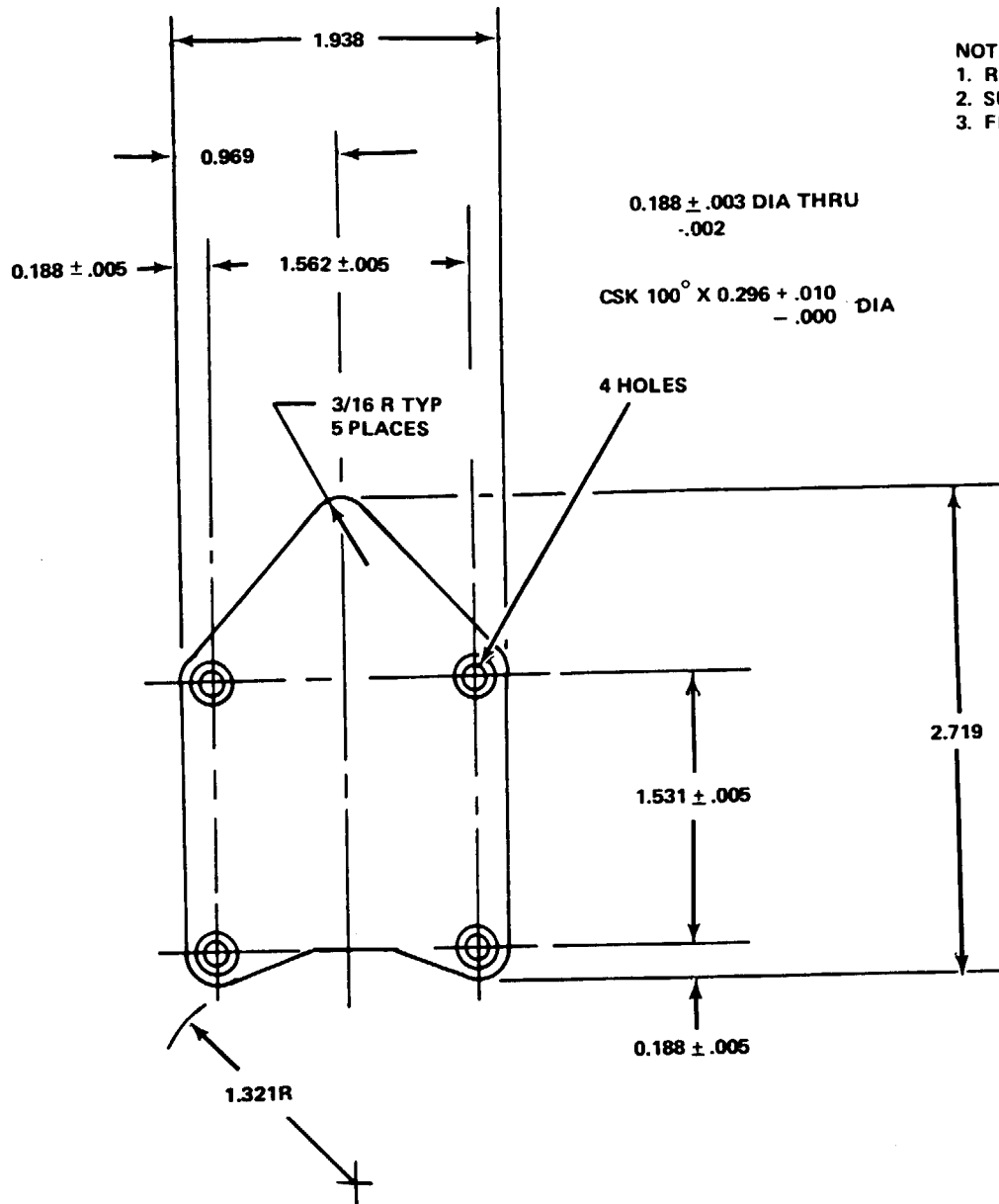
Figure D-27



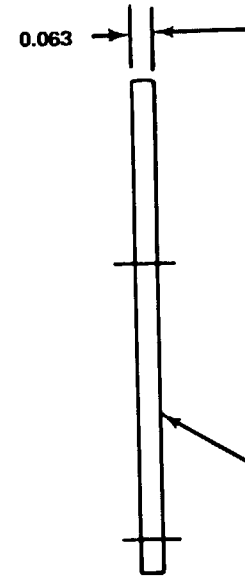
NOTES:

1. RUBBER, MIL-R-6855, CLASS II, GRADE 60, BLACK. - MAY BE USED AS AN ALTERNATE CLEAN SURFACES TO BE BONDED WITH
2. ACETONE, CHEM PURE, OR METHYL ETHYL KETONE. CHEM PURE

Figure D-28. Part Number 204-075-173-35, TUBING, Rubber  
Fabricate from: NSN 4720-00-231-2483  
Material: Tubing, Rubber, Natural, Federal Specification, 28-T-831 Grade A,  
0.125 Inch Wall Thickness

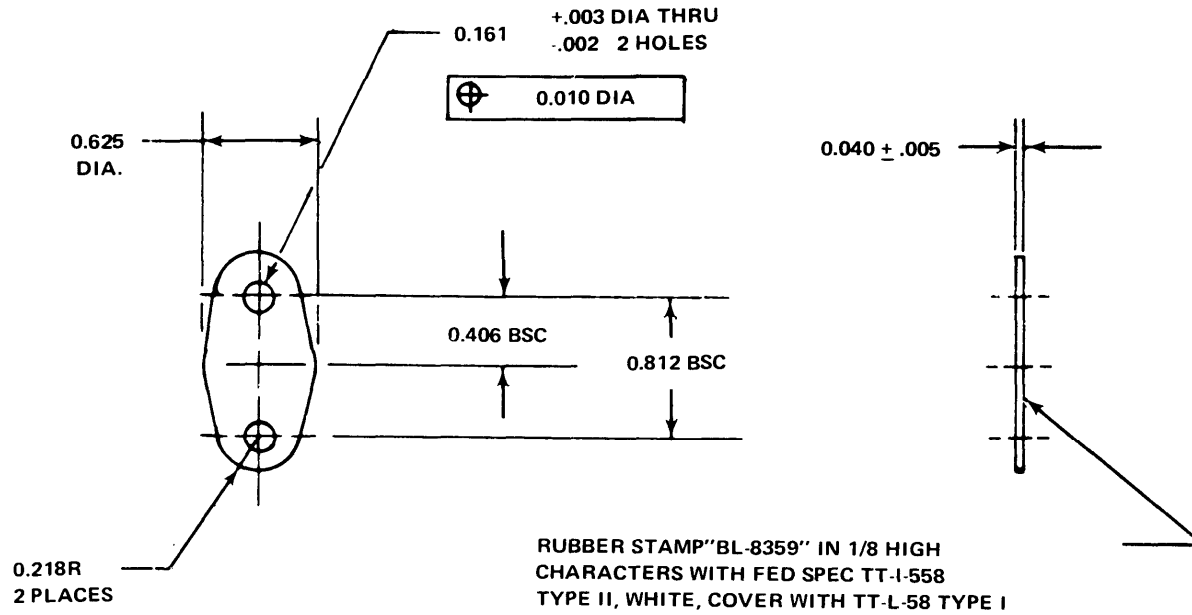


- NOTES:  
 1. REMOVE ALL BURRS & SHARP EDGES  
 2. SURFACE ROUGHNESS ALL OVER 125  
 3. FINISH: ANODIZE MIL-A-8625  
 TYPE II DYED BLACK



RUBBER STAMP "BL6150" IN 1/8 HIGH  
 CHARACTERS WITH FED SPEC TT-1-558  
 TYPE II WHITE. COVER WITH TT-L-58,  
 TYPE I.

Figure D-29. Part Number BL6750 COVER, IDLE GEAR  
 Fabricate from : NSN 9535-00-232-0378  
 Material: 2024 AL ALY Sheet, Federal Specification, QQ-A-250/5

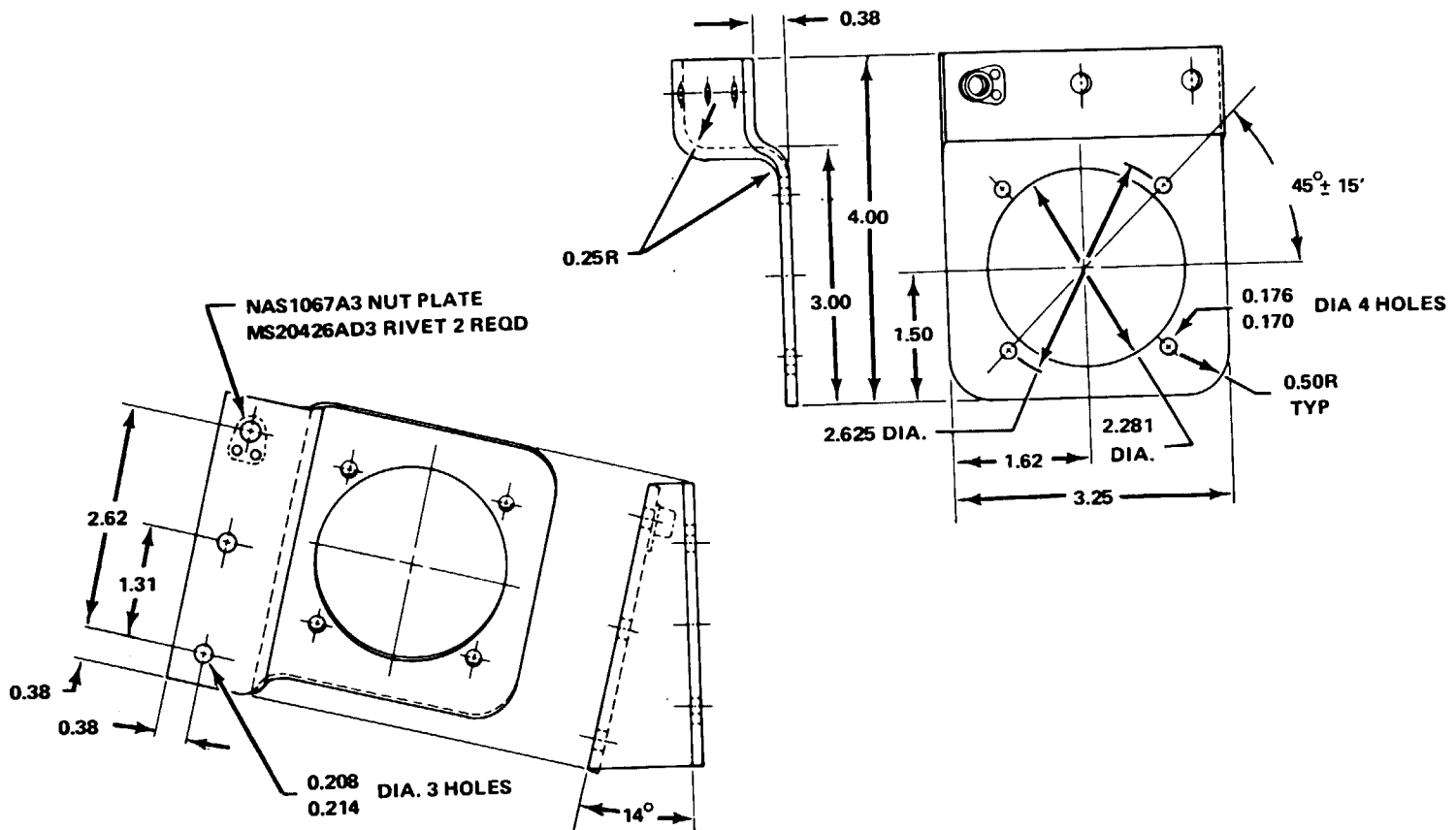


NOTES:

1. REMOVE ALL BURRS & SHARP EDGES
2. SURFACE ROUGHNESS AS ROLLED OR DRAWN PUNCHED, CUT OR MACHINED SURFACES TO HAVE 125
3. FINISH: ANODIZED PER MIL-A-8625 TYPE II, DYE BLACK

**Figure D-30.** Part Number BL8359 COVER, TENSION ROLL  
 Fabricate from: NSN 9535-00-167-2280  
 Material: 2024 AL ALY Sheet, Federal Specification QQ-A-250/5, 0.040 Inch Thick





**Figure D-31. Part Number**  
**Fabricate from:**  
**Material:**

204-070-476-1 **BRACKET ASSEMBLY, Standby Compass**  
**NSN 9535-00-232-0418, NSN 5310-00-021-3884**  
**2024 AL ALY, Sheet Federal Specification, QQ-A-250/5,**  
**0.125 Inch Thick**

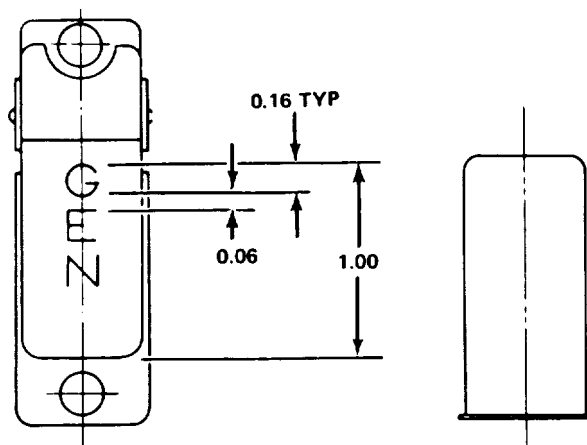


Figure D-32. Part Number: 204-075-207-3 SWITCH GUARD  
 Fabricate from: NSN 5830-00-681-4897  
 Material: Switch Guard - Make From P/N 8497K2, Switch Guard, Cutler Hammer Milwaukee, Wise. Code Ident No. 15605

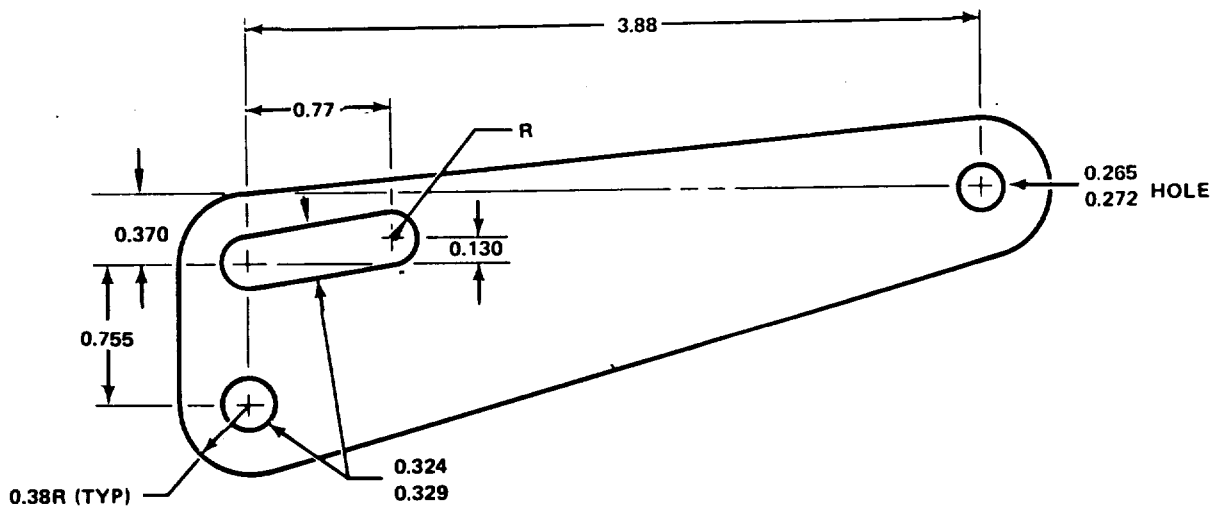


Figure D-33. part Number 204-070-855-7 PLATE - Cable Guide  
 Fabricate from: NSN 9535-00-232-0405  
 Material: 2024 AL ALY Sheet, Federal Specification QQ-A-250/5, 0.090 Inch Thick

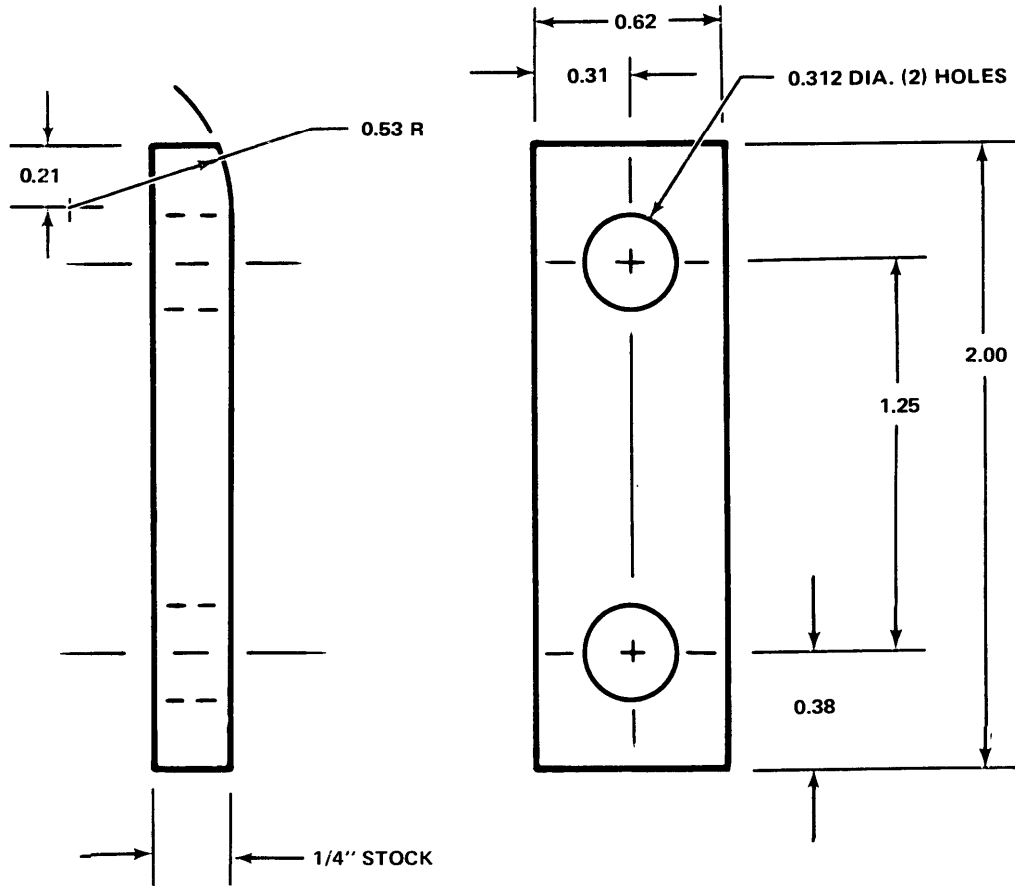
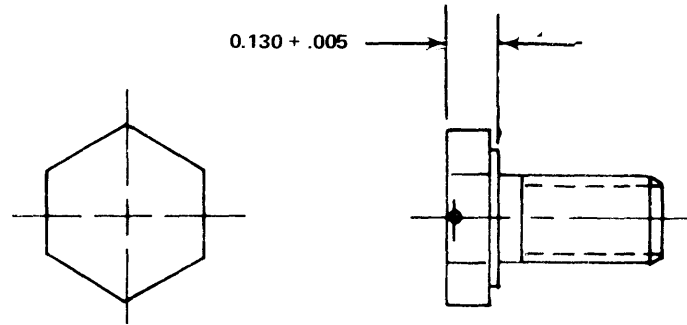


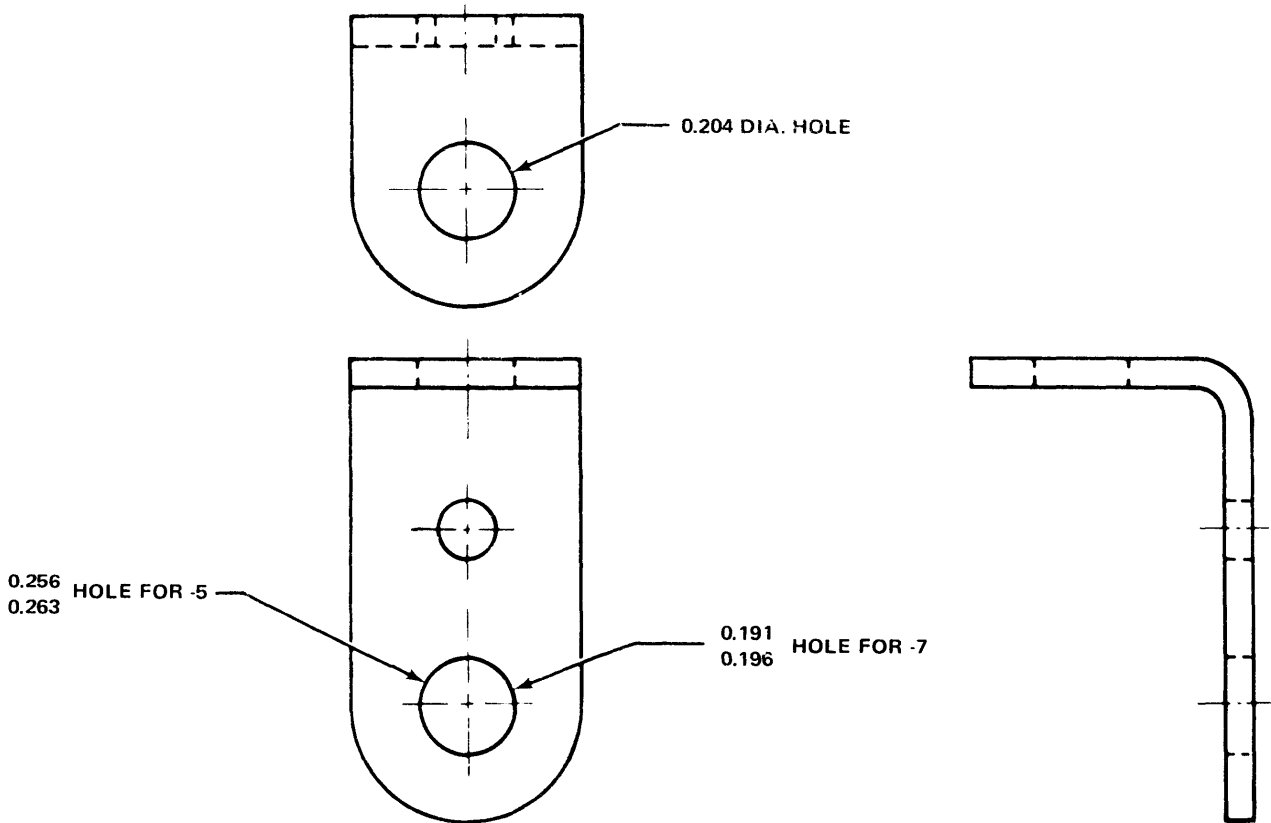
Figure D-34. Part Number 204-070-904-1 SPACER, Block-head Guard  
 Fabricate from: NSN 9330-00-260-3806  
 Material: Plastic Sheet Phenolic, Federal Specification MIL-P-15035 TYPE FBG 0.1875 Inch Thick



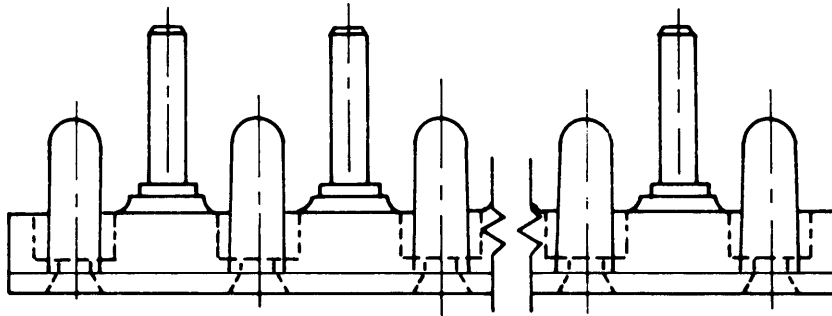
NOTES:

1. REMOVE ALL BURRS & SHARP EDGES
2. GRIND OR CUT HEAD OF BOLT TO DIM SHOWN

**Figure D-35.** Part Number BL8458 BOLT, MACHINE  
 Fabricate from: NSN 5306-00-180-2777  
 Material: Bolt, Machine, Cres. Passivated Finish, Make from AN4CN3A Bolt



**Figure D-36.** Part Number 204-075-143-5 & 7 BRACKET, Plug Mounting  
 Fabricate from: NSN 9535-00-232-0378  
 Material: 2024 ALALY Sheet, Federal Specification, QQ-A-250/5, 0.063 inch Thick



PART NUMBER	FABRICATE FROM NSN
MS27212-1-3	5940-00-950-1610
MS27212-1-9	5940-00-950-1610
MS27212-1-10	5940-00-950-1610
MS27212-1-12	5940-00-950-1610
MS27212-1-14	5940-00-950-1610
MS27212-1-15	5940-00-950-1610

NOTES:

1. LAST DASH NUMBER INDICATES NUMBER OF STUDS.
2. ALLOWANCE MUST BE MADE FOR THE LOSS OF ONE STUD FOR EACH CUT.

TERMINAL BLOCK

Figure D-37.



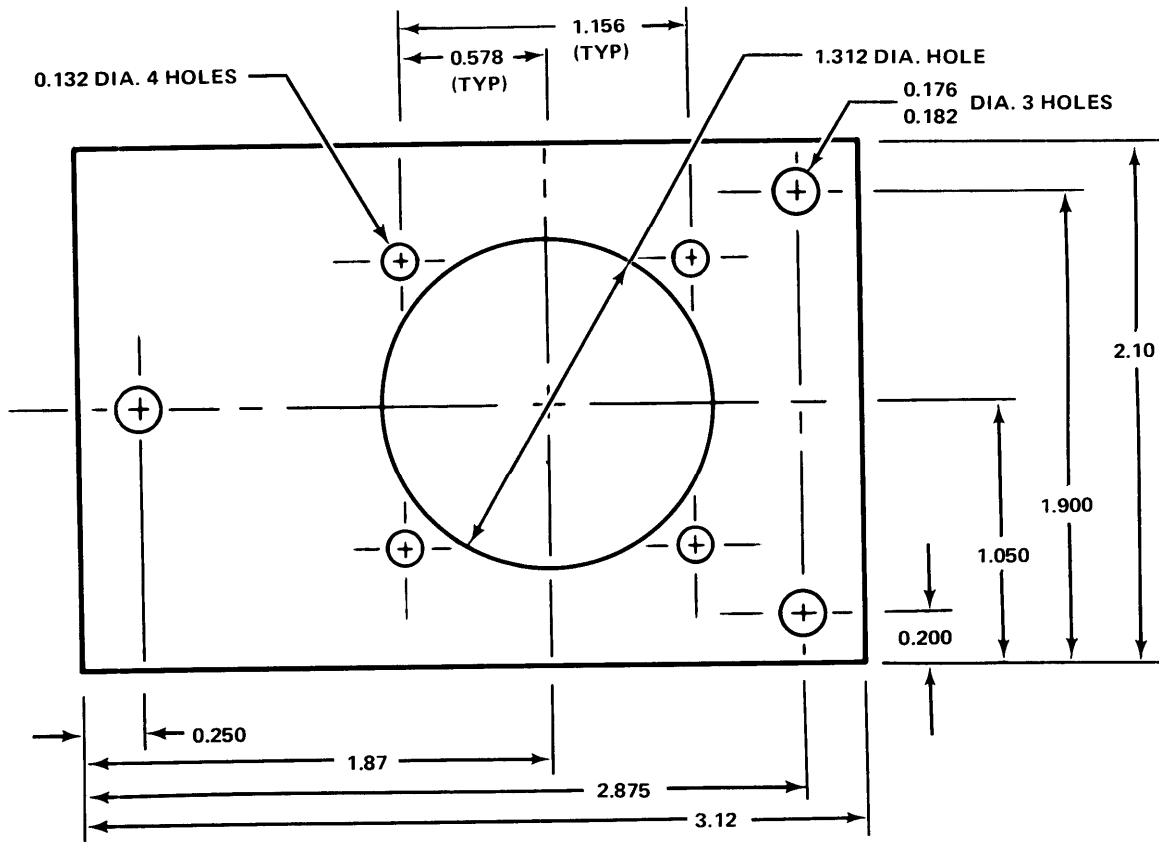


Figure D-39. Part Number  
Fabricate from:  
Material:

204-075-243-1 PLATE RECEPTACLE, Control Panel  
NSN 9535-00-086-9729  
2024 AL ALY Sheet, Federal Specification, QQ-A-250/5,  
0.032 Inch Thick

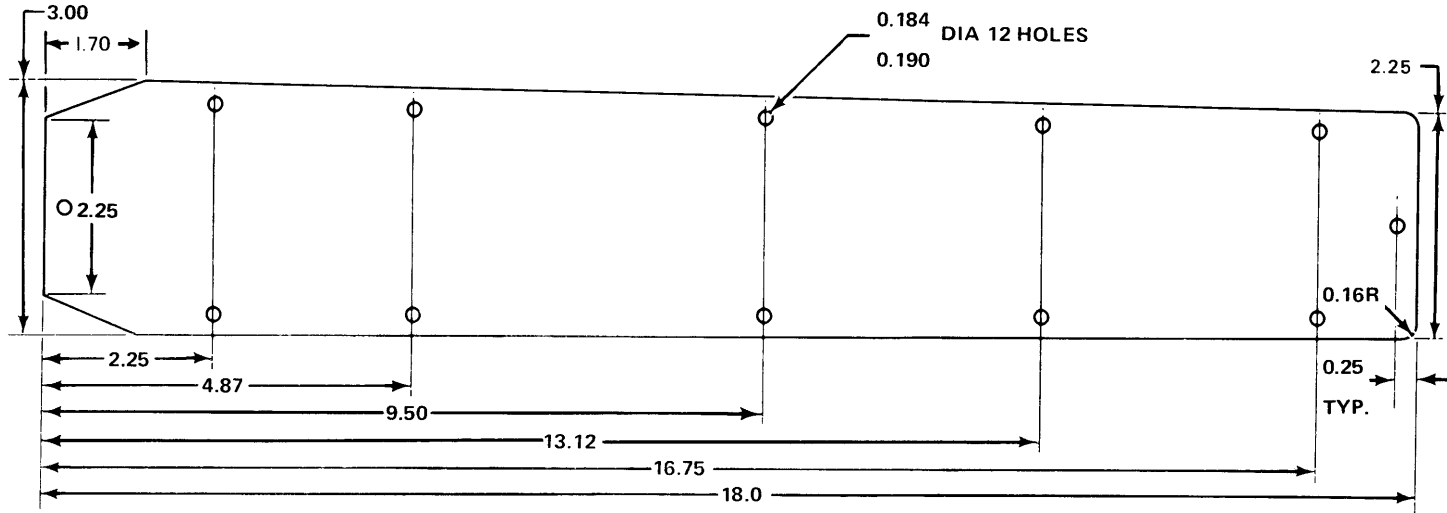


Figure D-40. Part Number 204-030-853-1333 DOOR  
Fabricate from: NSN 9535-00-086-9729  
Material: 2024 AL ALY, Sheet Federal Specification, QQ-A-250/5,  
0.032 Inch Thick



\*\*\*\*\*  
 \* CAUTION \*  
 \*\*\*\*\*

Use Teflon hose, NSN 4720-00-857-1732, when making fuel hose assemblies, P/N 640309-4-0250, MS8000E250C, MS8000E324C, and MS8000E216A.


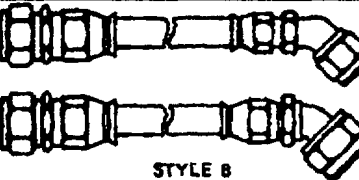
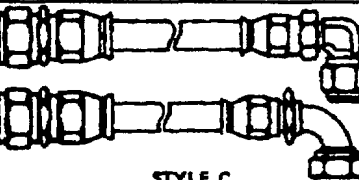
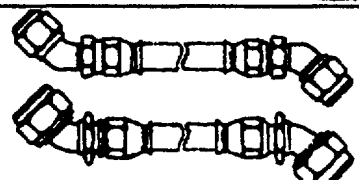
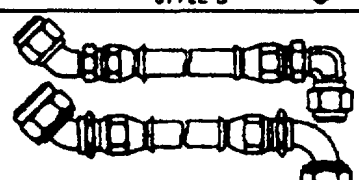
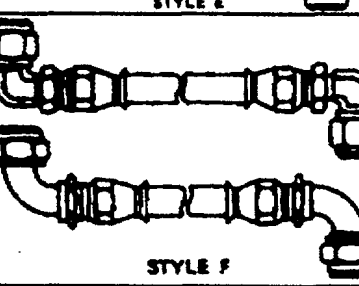
CONFIGURATION AND MATERIAL CORROSION RESISTANT STEEL (450°)		FITTING ENDS (MIL-P-27272)		(MIL-H-27267) HOSE CUT OFF FACTOR (HCOF) INCHES VS HOSE DASH SIZE NO.										
		1	2	-3C	-4C	-5C	-6C	-8C	-10C	-12C	-16C	-20C	-24C	
1	2													
 <p>ASSEMBLY LENGTH TYPICAL STYLE A</p>		MS27053	MS27053	1.40	1.48	1.54	1.62	1.86	2.10	2.26	2.60	2.88	3.32	
 <p>STYLE B</p>		MS27053	MS27059	1.78	1.92	1.99	2.10	2.72						
 <p>STYLE C</p>		MS27053	MS27060	1.56	1.65	1.74	1.84	2.24						
 <p>STYLE D</p>		MS27059	MS27059	2.16	2.36	2.44	2.58	3.58						
 <p>STYLE E</p>		MS27059	MS27060	1.94	2.09	2.19	2.37	3.10						
 <p>STYLE F</p>		MS27060	MS27060	1.72	1.82	1.94	2.06	2.62						
		MS27057	MS27057						2.82	3.84	4.10	4.68	5.36	
<p>EXAMPLE OF HOSE CUTOFF FACTOR                  FOR A -4, 1/4, TUBE OD, 18% ASSEMBLY LENGTH, STYLE D, THE BULK HOSE LENGTH IS 18.50 MINUS THE HCOF. = 18.50 - 2.36 = 16.14                  BULK HOSE LENGTH NEEDED IS 16.14 INCHES.</p> <p>FITTINGS TO MATE WITH PARTS DESIGNED TO MS33656</p>														

Figure D-41. Hose Assembly MS8000 Series (Sheet 1 of 9)


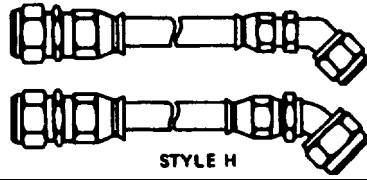
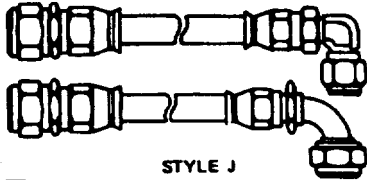
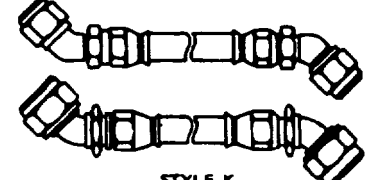
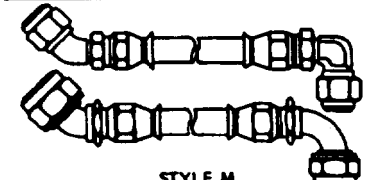
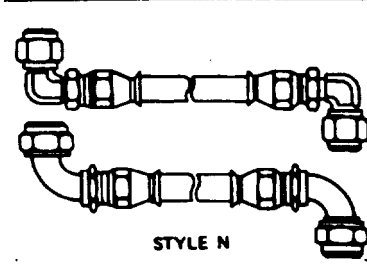
CONFIGURATION AND MATERIAL COMBINATION ALUMINUM AND CORROSION RESISTANT STEEL (275°)		FITTING ENDS (MIL-F-27272)		(MIL-H-27267) HOSE CUT OFF FACTOR (HCOF) INCHES VS HOSE DASH SIZE NO.									
		1	2	-3C	-4C	-5C	-6C	-8C	-10C	-12C	-16C	-20C	-24C
 <p>ASSEMBLY LENGTH TYPICAL STYLE G</p>		MS27053	MS27053					1.86	2.10	2.26	2.60	2.88	3.32
 <p>STYLE H</p>		MS27053	MS27059					2.72					
		MS27053	MS27055						2.63	3.18	3.44	3.86	4.41
 <p>STYLE J</p>		MS27053	MS27060					2.24					
		MS27053	MS27057						2.46	3.05	3.35	3.78	4.34
 <p>STYLE K</p>		MS27059	MS27059					3.58					
									3.16	4.10	4.28	4.84	5.50
 <p>STYLE M</p>								3.10					
									2.99	3.97	4.19	4.76	5.43
 <p>STYLE N</p>		MS27060	MS27060					2.62					
		MS27057	MS27057						2.82	3.84	4.10	4.68	5.34
<p>EXAMPLE OF HOSE CUTOFF FACTOR            FOR A -8, 1/2 TUBE OD, 18 1/2 ASSEMBLY LENGTH, STYLE K THE BULK HOSE            LENGTH - 18.50 MINUS THE HCOF, -18.50-3.58-14.92            BULK HOSE LENGTH NEEDED IS 14.92 INCHES.            FITTINGS TO MATE WITH PARTS DESIGNED TO MS33656</p>													

Figure D-41. Hose Assembly MS8000 Series (Sheet 2 of 9)

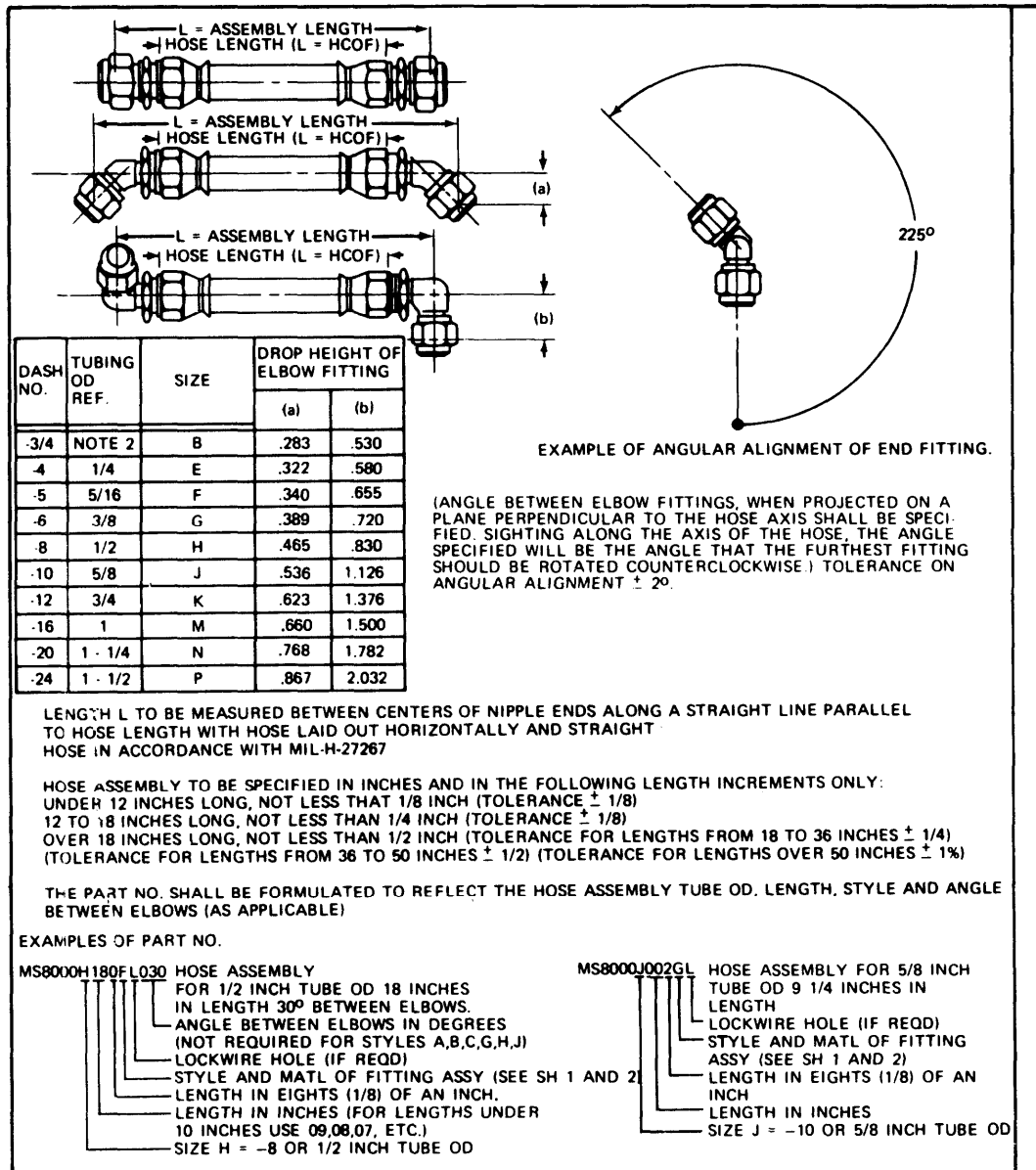


Figure D-41. Hose Assembly MS8000 Series (Sheet 3 of 9)


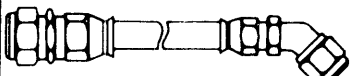
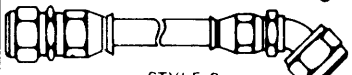
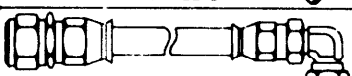
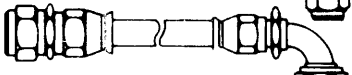
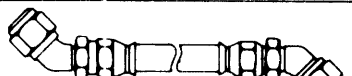
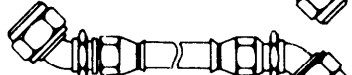
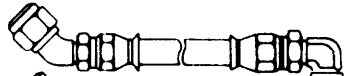
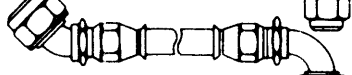
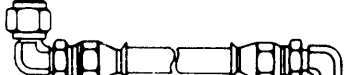
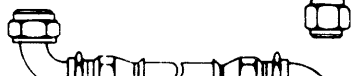


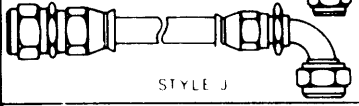

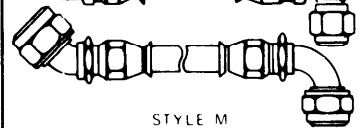
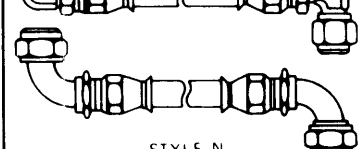
CONFIGURATION AND MATERIAL		CORROSION RESISTANT STEEL (450°F)												
		FITTING ENDS (MIL-F 27272)		(MIL-H 27267) HOSE CUT OFF FACTOR (HCOF) INCHES VS HOSE DASH SIZE NO.										
1	2	1	2	.3C	.4C	.5C	.6C	.8C	.10C	.12C	.16C	.20C	.24C	
ASSEMBLY LENGTH TYPICAL  STYLE A		MS27381	MS27381	1.84	1.78	1.86	2.04	2.32	2.64	2.80	3.16	3.44	4.14	
 STYLE B		MS27381	MS27384	2.15	2.18	2.25	2.45	3.11						
 STYLE B		MS27381	MS27382						3.09	3.63	3.91	4.33	5.10	
 STYLE C		MS27381	MS27385	1.78	1.80	1.90	2.05	2.47						
 STYLE C		MS27381	MS27383						2.73	3.32	3.63	4.06	4.75	
 STYLE D		MS27384	MS27384	2.46	2.58	2.64	2.86	3.90						
 STYLE D		MS27382	MS27382						3.54	4.46	4.66	5.22	6.06	
 STYLE E		MS27384	MS27385	2.09	2.20	2.29	2.46	3.26						
 STYLE E		MS27382	MS27383						3.18	4.15	4.38	4.95	5.71	
 STYLE F		MS27385	MS27385	1.72	1.82	1.94	2.06	2.62						
 STYLE F		MS27383	MS27383						2.82	3.84	4.10	4.68	5.36	
EXAMPLE OF HOSE CUTOFF FACTOR FOR A 6, 3/8 TUBE OD, 20 1/2 ASSEMBLY LENGTH, STYLE A THE BULK HOSE LENGTH = 20.50 MINUS THE HCOF, = 20.50 - 2.04, = 18.46 BULK HOSE LENGTH NEEDED IS 18.46 INCHES														

Figure D-41. Hose Assembly MS8001 Series (Sheet 4 of 9)

CONFIGURATION AND MATERIAL COMBINATION ALUMINUM AND CORROSION RESISTANT STEEL (275°)		FITTING ENDS (MIL-F 27272)		(MIL-H 27267) HOSE CUT OFF FACTOR (HCOF) INCHES VS HOSE DASH SIZE NO.									
		1	2					.8C	.10C	.12C	.16C	.20C	.24C
 ASSEMBLY LENGTH TYPICAL STYLE G	MS27381	MS27381						2.32	2.64	2.80	3.16	3.44	4.14
	MS27381	MS27384						3.11					
 STYLE H	MS27381	MS27382						3.09	3.63	3.81	4.33	5.10	
	MS27381	MS27383						2.47					
 STYLE J	MS27381	MS27383						2.73	3.32	3.63	4.06	4.75	
	MS27384	MS27384						3.90					
 STYLE K	MS27382	MS27382						3.54	4.46	4.66	5.22	6.06	
	MS27384	MS27385						3.26					
 STYLE M	MS27382	MS27383						3.18	4.15	4.38	4.95	5.71	
	MS27385	MS27385						2.62					
 STYLE N	MS27383	MS27383						2.82	3.84	4.10	4.68	5.36	

EXAMPLE OF HOSE CUTOFF FACTOR  
 FOR A .8, 1/2 TUBE OD, 20 1/2 ASSEMBLY LENGTH, STYLE G THE BULK HOSE  
 LENGTH = 20.50 MINUS THE HCOF, = 20.50 - 2.32 = 18.18  
 BULK HOSE LENGTH NEEDED IS 18.18 INCHES

Figure D-41. Hose Assembly MS8001 Series (Sheet 5 of 9)

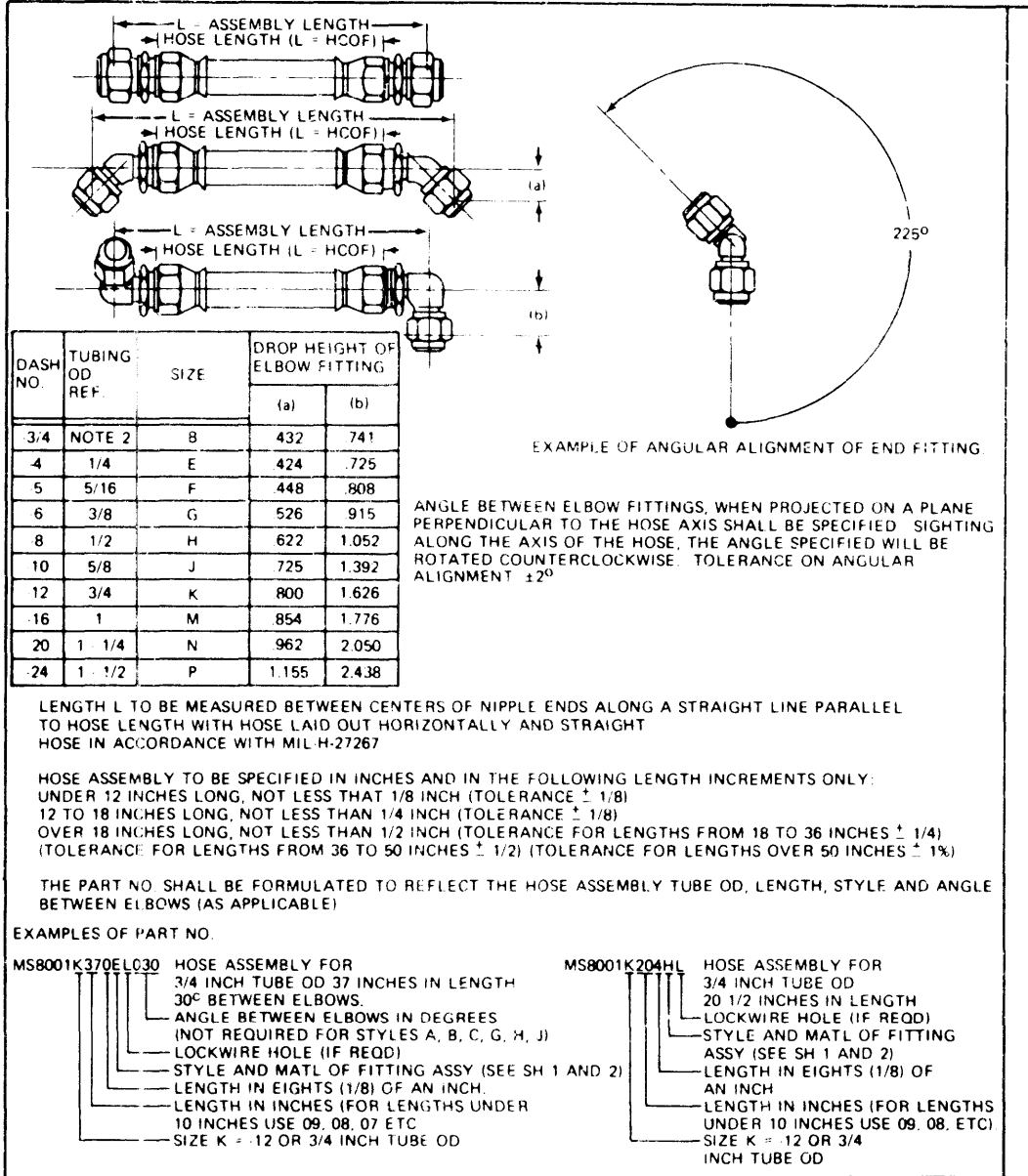
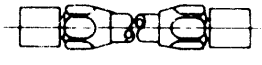

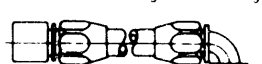
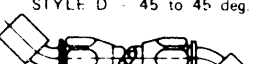
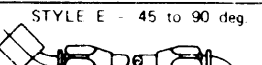
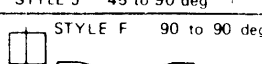


Figure D-41. Hose Assembly MS8001 Series (Sheet 6 of 9)

HOSE ASSEMBLY		MS87028	MS87029	MS87030	MS87031	MS87032	
CONFIGURATION		PART NUMBERS OF FITTINGS					
FIG NO. 1	FIG NO. 2	FIG NOS.	FLARE TO FLARE	FLARELESS TO FLARELESS	FLARE TO FLANGE	FLARELESS TO FLANGE	FLANGE TO FLANGE
STYLE A - straight to straight  MS87027 HOSE		1	MS87018	MS87021	MS87018	MS87021	MS87024
		2	MS87018	MS87021	MS87024	MS87024	MS87024
STYLE B - straight to 45 deg  MS87027 HOSE STYLE G - straight to 45 deg		1	MS87018	MS87021	MS87018	MS87021	MS87024
		2	MS87019	MS87022	MS87025	MS87025	MS87025
		1			MS87024	MS87024	
		2			MS87019	MS87022	
STYLE C - straight to 90 deg  MS87027 HOSE STYLE H - straight to 90 deg		1	MS87018	MS87021	MS87018	MS87021	MS87024
		2	MS87020	MS87022	MS87026	MS87026	MS87026
		1			MS87024	MS87024	
		2			MS87020	MS87023	
STYLE D - 45 to 45 deg  MS87027 HOSE		1	MS87019	MS87022	MS87019	MS87022	MS87025
		2	MS87019	MS87022	MS87025	MS87025	MS87025
STYLE E - 45 to 90 deg  MS87027 HOSE STYLE J - 45 to 90 deg		1	MS87019	MS87022	MS87019	MS87022	MS87025
		2	MS87020	MS87023	MS87024	MS87026	MS87026
		1			MS87025	MS87025	
		2			MS87020	MS87023	
STYLE F - 90 to 90 deg  MS87027 HOSE		1	MS87020	MS87023	MS87020	MS87023	MS87026
		2	MS87020	MS87023	MS87026	MS87026	MS87026

**NOTES**

1. Fittings shall mate with MS3314, MS33656 or MS33786 end fittings, as applicable.
2. For design and size of fittings, see corresponding dash number on applicable MS standard.
3. Identification: See procurement specification.
4. Dimensions in inches.
5. Referenced documents shall be of the issue in effect on date of invitation for bids.
6. For design feature purposes, this standard takes precedence over procurement documents referenced herein.

Figure D-41. Hose Assembly MS87028 thru MS87032 Series (Sheet 7 of 9)

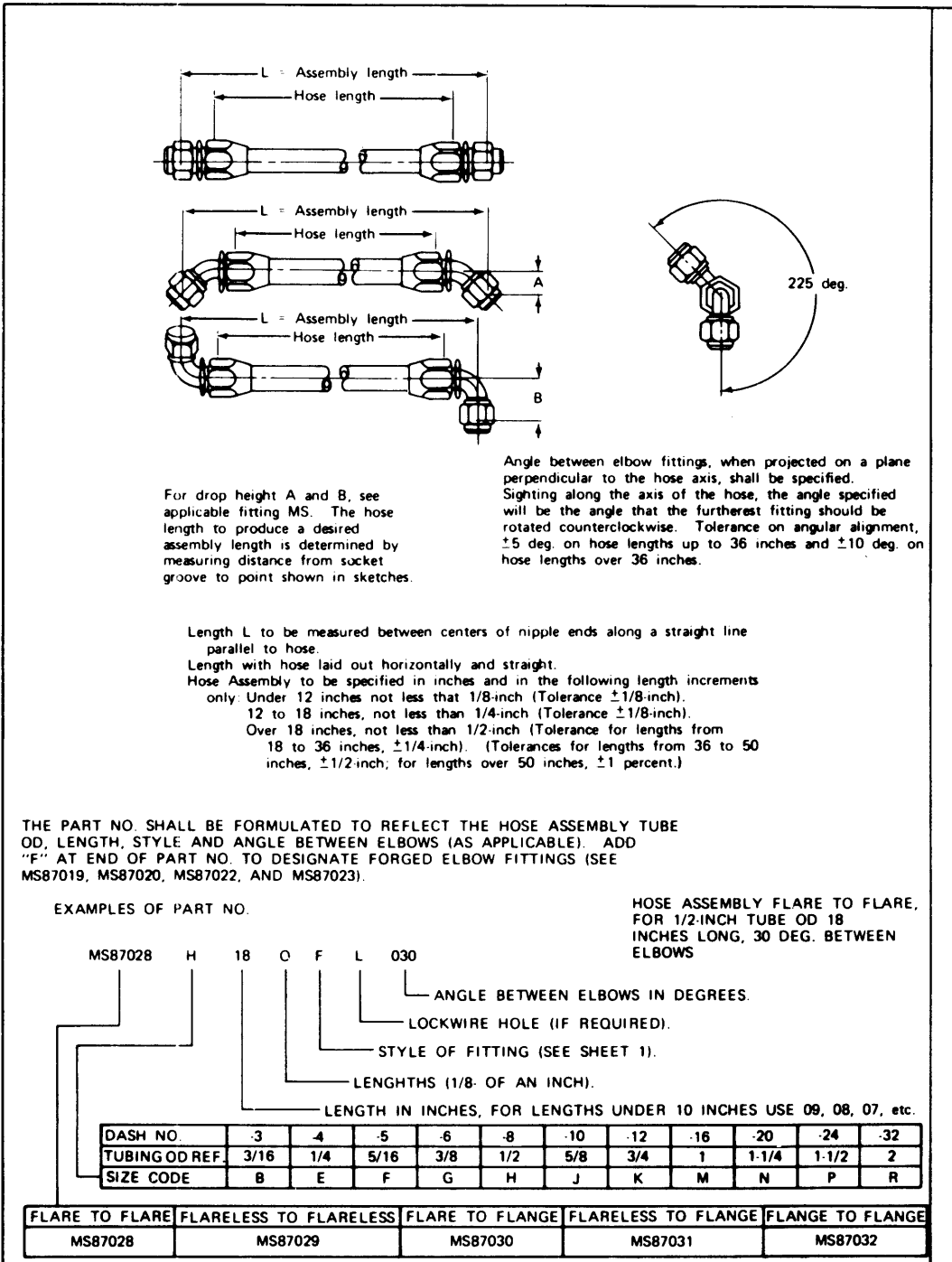
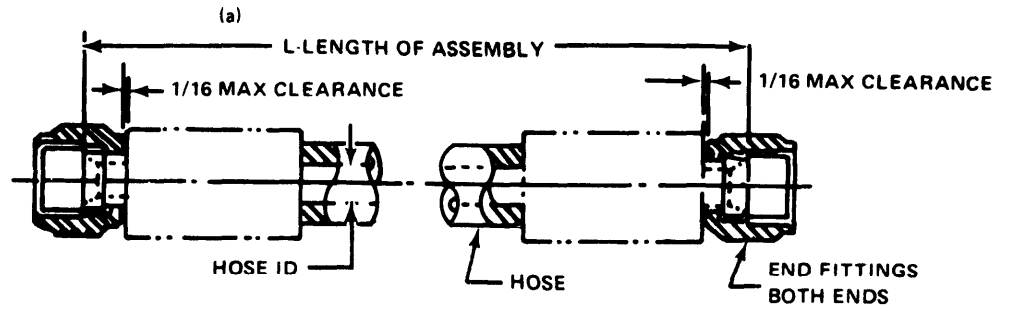


Figure D-41. Hose Assembly MS87028 thru MS87032 Series (Sheet 8 of 9)





MS ASSEMBLY NO.	TUBING OD REF	HOSE ID REF	END FITTING
(b) MS2871-3	3/16	1/8	MS24587-3
MS28741-4	1/4	3/16	MS24587-4
MS28741-3	3/16	1/4	MS24587-5
MS28741-6	3/8	5/16	MS24587-6
MS28741-8	1/2	13/32	MS24587-8
MS28741-10	3/8	1/2	MS24587-10
MS28741-12	3/4	5/8	MS24587-12
MS28741-16	1	7/8	MS24587-14
MS28741-20	1-1/4	1-1/8	MS24587-20
MS28741-24	1-1/2	1-3/8	MS24587-24
MS28741-32	2	1-13/16	MS24587-32

NOTES:

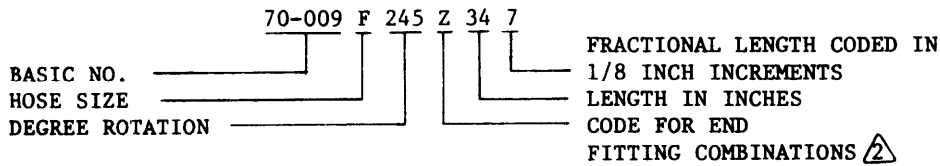
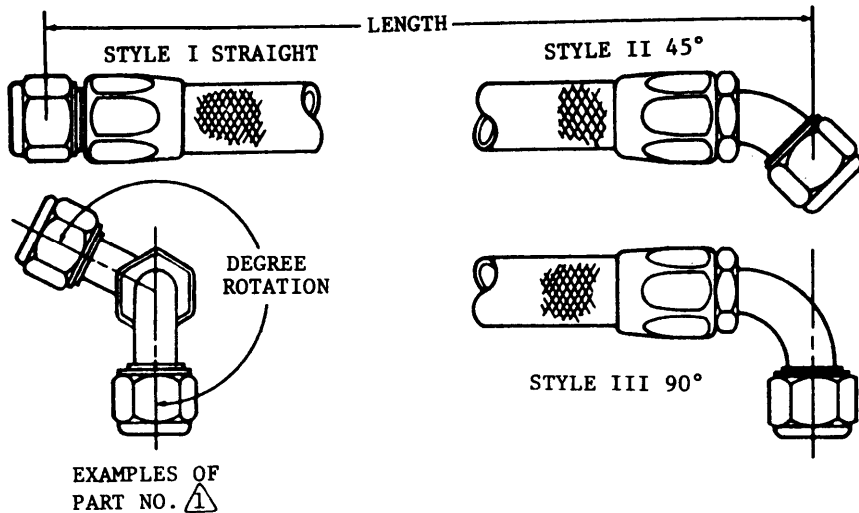
- (a) HOSE ASSEMBLIES TO BE SPECIFIED IN THE FOLLOWING LENGTH INCREMENTS ONLY
  - 12 INCHES LONG AND UNDER - NOT LESS THAN 1/8
  - 12 TO 18 INCHES LONG - NOT LESS THAN 1/4
  - OVER 18 INCHES LONG - NOT LESS THAN 1/2
- (b) ASSEMBLY NUMBER MS28741-3 INACTIVE FOR DESIGN FOR HYDRAULIC USE.
  - MS224587 END FITTINGS ARE DIMENSIONALLY AND FUNCTIONALLY INTERCHANGEABLE WITH MS28740. END FITTINGS SHALL CONFORM TO MIL-A-5070
  - ASSEMBLIES SHALL BE PROOF PRESSURE TESTED IN ACCORDANCE WITH SPECIFICATION MIL-M-8795.
  - SEE MIL-M-8796 FOR USE, OPERATING PRESSURE AND AGE CONTROL OF HOSE ASSEMBLY
  - MS ASSEMBLY NUMBERS FOR USE OF AIRCRAFT CONTRACTORS AND HOSE ASSEMBLIES ONLY
  - PROVISIONING PARTS BREAKDOWN MUST LIST COMPONENT PARTS SPARE AND MAINTENANCE PARTS
  - ARE NOT TO BE ORDERED BY SERVICES UNDER THE ASSEMBLY NUMBER SERVICES TO ORDER END FITTINGS BY THEIR INDIVIDUAL PART NUMBER AND HOSE CONFORMING TO MIL-M-8794.
- © EACH HOSE ASSEMBLY SHALL BE IDENTIFIED WITH A DURABLE PERMANENTLY ATTACHED TAG PLAINLY MARKED WITH THE MILITARY STANDARD (MS) HOSE ASSEMBLY NUMBER, DATE OF ASSEMBLY, CURE DATE OF THE HOSE, AND THE MANUFACTURER'S NAME AND PART NUMBER. THE NAME, TRADEMARK OR SYMBOL OF THE HOSE ASSEMBLER SHALL BE IMPRESSION STAMPED OR VIBRATOR ETCHED ON A BLANK SURFACE OF BOTH END ADAPTERS.
  - EXAMPLE OF PART NUMBER: MS28741-8-0184 - HOSE ASSEMBLY FOR 1/2 OD TUBING - LENGTH - 18-1/2 INCHES
  - FRACTIONS IN EIGHTHS OF AN INCH
    - INCHES
    - SIZE

LENGTH L SHALL ALWAYS BE SPECIFIED BY FOUR DIGITS, THE LAST DIGIT SHALL ALWAYS INDICATE FRACTIONS BY EIGHTHS OF AN INCH

DIMENSIONS IN INCHES UNLESS OTHERWISE SPECIFIED, TOLERANCE LENGTH L

- 1/8 (L UNDER 18)
- 1/4 (L FROM 18 TO 36)
- 1/2 (L OVER 36 TO 50)
- 1 PERCENT (L OVER 50)

Figure D-41. Hose Assembly MS28741 Series (Sheet 9 of 9)

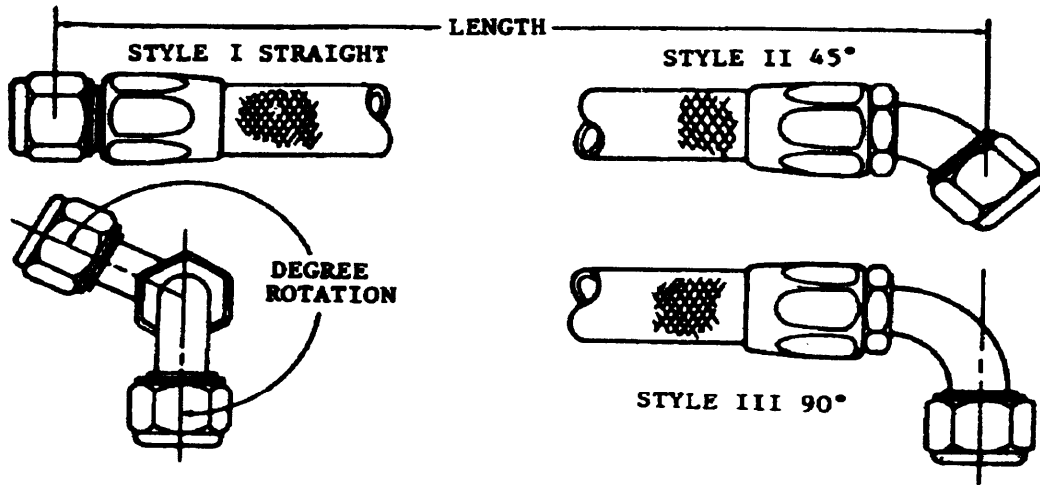


HOSE SIZE	3	4	5	6	8	10	12	16	20	24	32	= TUBING O.D. IN 1/16 IN.
CODE LETTER	E	F	G	H	J	K	L	M	N	P	R	INCREMENTS

STYLES AND MATERIALS OF END FITTINGS (FLARED)				
Combinations Code 2	Material	Fitting Style	Material	Fitting Style
A	Alum.	I	Alum.	I
B	Alum.	II	Alum.	II
C	Alum.	III	Alum.	III
D	Steel	I	Steel	I
E	Steel	II	Steel	II
F	Steel	III	Steel	III
G	Alum.	I	Steel	III
H	Alum.	I	Steel	II
T	Alum.	I	Alum.	II
V	Alum.	I	Alum.	III
W	Alum.	II	Alum.	III
X	Steel	I	Steel	II
Y	Steel	I	Steel	III
Z	Steel	II	Steel	III

1 P/N 70-009 HOSE ASSEMBLIES SHALL BE FABRICATED SO THAT THE FIRE SLEEVE WILL COVER THE SOCKET FOR THE FITTING. ON AL ALY SOCKETS, THE FIRE SLEEVE COVERING THE FULL LENGTH OF THE SOCKET SHALL BE PROTECTED WITH SILICONE RUBBER AND SHALL BE BONDED, USING END DIP COMPOUND, TO THE SOCKET AT THE END TO PREVENT MOISTURE ENTRAPMENT.

Figure D-41.1. Hose Assembly, Fire Resistant (70-009 Series)



PART NO. CODE: 70-010 J 240 C 48 4 FRACTIONAL LENGTH CODED IN 1/8 INCH INCREMENTS  $\Delta$   
 BASIC NO. HOSE SIZE DEGREE ROTATION LENGTH IN INCHES  $\Delta$   
 CODE FOR END FITTING COMBINATIONS  $\Delta$

HOSE SIZE WITHOUT CHAFE GUARD  $\Delta$  WITH CHAFE GUARD

3	4	5	6	8	10	12	16	20	24	32	= TUBING O.D.
E	F	G	H	J	K	L	M	N	P	R	IN 1/16 IN.
S	T	U	V	W	X	Y	Z	A	B	C	INCREMENTS

STYLES AND MATERIALS OF END FITTINGS (FLARED)				
Combinations Code $\Delta$	Material	Fitting Style	Material	Fitting Style
A	Alum.	I	Alum.	I
B	Alum.	II	Alum.	II
C	Alum.	III	Alum.	III
D	Steel	I	Steel	I
E	Steel	II	Steel	II
F	Steel	III	Steel	III
G	Alum.	I	Steel	III
H	Alum.	I	Steel	II
T	Alum.	I	Alum.	II
V	Alum.	I	Alum.	III
W	Alum.	II	Alum.	III
X	Steel	I	Steel	II
Y	Steel	I	Steel	III
Z	Steel	II	Steel	III

**E** PROVISIONS MADE TO CALLOUT HOSE WITH CHAFE GUARD

Figure D-41.2. Hose Assembly, Non-Fire Resistant (Sheet 1 of 2)

EXAMPLE OF CALLOUT:

70-010J240C484 = HOSE ASSEMBLY-NON FIRE RESISTANT, .5 INCH O.D., 240° ROTATION, 90° ALUMINUM FITTINGS BOTH ENDS, 48.5 INCHES LONG, WITHOUT CHAFE GUARD.

70-010W000C480 = HOSE ASSEMBLY-NON FIRE RESISTANT, .5 INCH O.D., 0° ROTATION, 90° ALUMINUM FITTINGS BOTH ENDS, 48.0 INCHES LONG, WITH CHAFE GUARD.

**NOTES: I. SIMILAR TO MS87028 THRU MS87032 EXCEPT HOSE ASSEMBLY SHALL CONFORM TO BELL PROCUREMENT SPECIFICATION 299-947-045, CLASS "A".**

2. ON HOSE SIZES 3, 4, AND 5; ALUMINUM FORGED BODY IS INACTIVE FOR FUTURE INSTALLATION AND DESIGN.

3. FOR NEW DESIGN, FRACTIONAL LENGTH HOSES SHALL BE SPECIFIED IN THE FOLLOWING INCREMENTS ONLY:

(a) UNDER 18 INCHES LONG = 1/4 INCH INCREMENTS ONLY. (2, 4, OR 6 ONLY)

(b) OVER 18 INCHES LONG = 1/2 INCH ONLY (4 ONLY)

4. HOSE ASSEMBLY SHALL BE CERTIFIED TO THE FOLLOWING BY TSO TAG ATTACHED:

FAA TSO-C53a TYPE A

5. IDENTIFY WITH BELL STANDARD PART NUMBER.

6. MAXIMUM LENGTH OF HOSE ASSEMBLY IS 99.5 INCHES LONG

7. CHAFE GUARD TO BE TRANSLUCENT VINYL PLASTIC PER MIL-I-7444 TYPE I, AND SHALL COME WITHIN .19 OF FITTING EACH END.

(E)

**Figure D-41.2. Hose Assenbly, Non-Fire Resistant (Sheet 2 of 2)**

D-1. TUBE BENDING DATA. The information contained in this section discloses, as applicable, quantities of material and fittings, bend radii, angles, dimension, and all other data required for fabrication of tube assemblies.

- a. Table D-3 gives the material, NSN's, and quantities of the stock required to fabricate each tube assembly. The stock dimension column will indicate a length of 2 to 3 inches longer than is actually required for the finished tube. The last column includes the applicable system for each tube assembly, such as Fuel, Lubrication, etc.
- b. Figure D-42 illustrates the type of dial marking, end references ("X" and "Y"), and dimensional references ("A" and "B"), to coincide with the data on Table D-4, The Type of Ends (I thru VI) are defined, and the "Notes" are provided for additional information.
- c. Table D-4 includes all the dimensions (inches), angles (degrees), and other information required to fabricate the tube assemblies. The use of Table D-4 is described in the following example. The columns are numbered for reference only.

EXAMPLE

1	2	3	4	5	6	7
PART NUMBER	BEND NO.	DIMENSION "A" FROM "Y" END	BEND RADIUS	DIAL SETTING	BEND ANGLE	END FITTING AND NOTES
		DIMENSION "B"	TYPE END "Y"	TYPE END "X"	PRESSURE TEST	
205-061-619-1	1	1-1/16	9/16	0	45	Y - AN818-4D MS20819-4D
	2	9/8	9/16	185	68	
			11 3/8	III	V	N/A

Column 1. PART NUMBER – Tube Part Number in alpha numerical order.

Column 2. BEND NO. – Bend Number 1, 2, etc., numbering from "Y" end of tube. The last block in Column 2 will be blank.

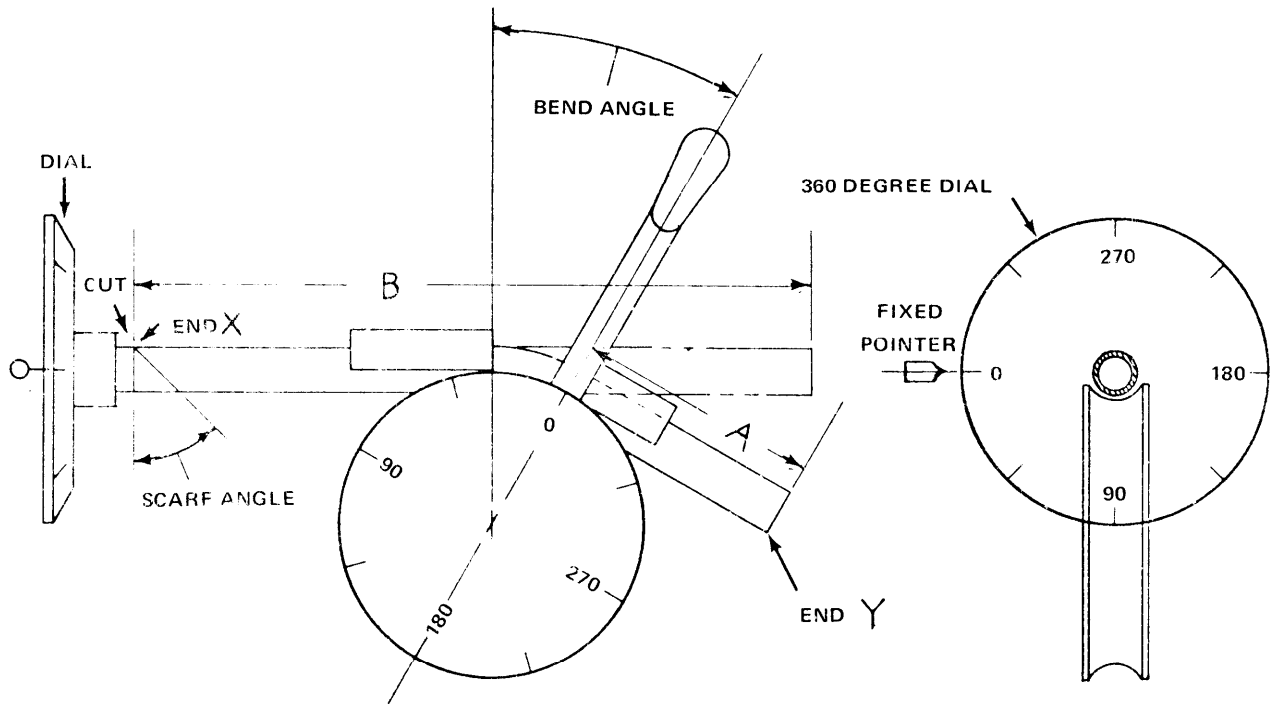
Column 3. DIMENSION "A" FROM "Y" END – Refer to Figure D-42. Dimension "A" is the distance from "Y" End before bending, to the beginning point of each bend to be performed. (See Example.) "A" dimension for No. 1 bend is 1-1/16 inch. "A" dimension for No. 2 bend is 9/8 inch,

DIMENSION "B" – Dimension "B" is the exact tube length before tube is bent, including allowances for flaring or beading ends. (See Example.) "B" Dimension is 1 1 3/8 inches.

Column 4. BEND RADIUS – Specifies the radius of each bend. (See Example.) Bend Radius for Nos. 1 and 2 bends is 9/16 inch.

TYPE END "Y" – Refers to type of end(I thru VI). See Figure D-42, "Type of Ends", for definition. (See Example.) Type of End "Y" is III, indicating a Double Flare.





NOTES:

1. SELECT MATERIAL AND END FITTINGS FROM TABLE D-3.
2. REFER TO TUBE BENDING DATA, TABLE D-4, FOR ALL DIMENSIONS, ANGLES, AND DIAL SETTINGS.
3. MARK DIMENSION "A" FOR EACH BEND, AND DIMENSION "B" PRIOR TO BENDING.
4. MAKE FIRST BEND WITH DIAL SET AT 0 DEG AND ROTATE DIAL TO "RIGHT" (CLOCKWISE) AND MAKE REMAINING BENDS AT SPECIFIED DIAL SETTINGS.
5. CUT "X" END AFTER BENDING. IF SCARF IS REQUIRED SET DIAL AND CUT TO SPECIFIED ANGLE.
6. TRIM AND BURR ENDS "X" AND "Y" AS NECESSARY.
7. BEND RADI SHALL CONFORM TO MS33611.
8. NUTS AND SLEEVES INSTALLED PER MS33566.
9. PRESSURE TEST TO PSI CALLED OUT IN TUBE BENDING DATA, TABLE D-4, IF APPLICABLE.
10. IDENTIFY TUBE ASSEMBLY BY MARKING PART NUMBER WITH RUBBER INK STAMP OR FELT PEN.

TYPE OF ENDS

- I SINGLE FLARE - MS33584
- II BEAD - MS33660 TYPE "A" UNLESS NOTED.
- III DOUBLE FLARE - MS33583
- IV PLAIN SQUARE
- V ANGLE - 45° SCARF UNLESS NOTED.
- VI OTHER - AS DESIGNATED

Figure D-42.

Column 5. DIAL SETTING — The dial setting is the degree of tube rotation from plane of first bend. The dial setting (degree of tube rotation) will depend on the type of dial marking used. The dial settings referenced in Table D-4 correspond to the type of dial marking illustrated in Figure D-42.

TYPE OF END ‘X’ — Refers to type End (I thru VI). See Figure D-42 “Type of Ends”, for definition. (See Example.) Type of End “X” is V, indicating “Angle 45 degrees scarf.”

Column 6. BEND ANGLE — Specifies the degree of bend through which the tube is bent, as shown in Figure D-42. (See Example.) The bend angle (degree of bend) for 1st bend is 45 degrees, 2nd bend is 68 degrees.

#### NOTE

This is the actual number of degrees required in the bend. When pressure is released from the tube bender, a small amount of “spring back” varying in proportion to hardness and elongation characteristics of the tubing will necessitate a certain amount of over-run to accomplish the exact bend angle.

PRESSURE TEST — The pressure test, if applicable, is indicated in psi (pounds per square inch). (See Example. ) Pressure test is indicated as N/A, meaning “Not Applicable”.

Column 7. END FITTINGS AND NOTES — The Part Number of End Fitting, if required, and their identity to the correct End (“X” and “Y”) are referenced. Additional notes will be included in this column, as required. (See Example.) The End Fittings for “Y” End are AN818-4D and MS20819-4D. For “X” End, no fittings are required. A scarf is cut on End “X”, with dial setting at 320 degrees.



<u>ITEM NUMBER</u>	<u>PART NUMBER</u>	<u>NSN</u>	<u>NOMENCLATURE</u>
1.	MIL-H-27267-10	4720-00-857-1730	Hose
2.	MIL-H-27267-12	4720-00-857-1734	Hose
3.	MIL-H-27267-16Z	4720-00-857-1729	Hose
4.	MIL-H-27267-4	4720-00-857-1732	Hose
5.	MIL-H-27267-5	4720-00-857-1736	Hose
6.	MIL-H-27267-6	4720-00-857-1731	Hose
7.	MIL-H-27267-8	4720-00-815-6354	Hose
8.	MIL-H-8794-4	4720-00-639-9907	Hose
9.	601-10	4720-00-541-8328	Hose
10.	M83797/1-KR	4720-00-555-3499	Hose
11.	MS87027-16R	4720-00-540-6434	Hose
12.	MS87027-4	4720-00-541-9281	Hose
13.	MS87027-6	4720-00-611-2548	Hose
14.	MS87027-8	4720-00-580-6618	Hose
15.	MS24587-4	4730-00-842-2200	Fitting Assembly
16.	MS27053-10	4730-00-125-2640	Fitting Assembly
17.	MS27053-10C	4730-00-889-2477	Fitting Assembly
18.	MS27053-12	4730-00-935-9382	Fitting Assembly
19.	MS27053-12C	4730-00-889-2478	Fitting Assembly
20.	MS27053-16	4730-00-889-2473	Fitting Assembly
21.	MS27053-4C	4730-00-889-2474	Fitting Assembly
22.	MS27053-6C	4730-00-982-9736	Fitting Assembly
23.	MS27053-8C	4730-00-889-2476	Fitting Assembly
24.	MS27055-10C	4730-00-884-1232	Fitting Assembly
25.	MS27055-12	4730-00-935-9383	Fitting Assembly
26.	MS27055-12C	4730-00-884-1234	Fitting Assembly
27.	MS27055-16	4730-00-884-1231	Fitting Assembly
28.	MS27057-10C	4730-00-132-3162	Fitting Assembly
29.	MS27057-12	4730-00-130-4269	Fitting Assembly
30.	MS27057-12C	4730-00-132-3163	Fitting Assembly
31.	MS27057-16	4730-00-135-8851	Fitting Assembly
32.	MS27059-4C	4730-00-889-2465	Fitting Assembly
33.	MS27059-6C	4730-00-889-2468	Fitting Assembly
34.	MS27060-4C	4730-00-013-6970	Fitting Assembly
35.	MS27060-6C	4730-00-013-6969	Fitting Assembly
36.	MS27060-8C	4730-00-228-1106	Fitting Assembly
37.	MS27381-12	4730-00-054-7661	Fitting Assembly
38.	MS27381-4C	4730-00-054-7650	Fitting Assembly
39.	MS27381-5C	4730-00-877-9876	Fitting Assembly
40.	MS273831-6C	4730-00-053-0379	Fitting Assembly
41.	MS27381-8	4730-00-053-0389	Fitting Assembly
42.	MS27381-8C	4730-00-929-5705	Fitting Assembly
43.	MS27382-12	4730-00-053-0411	Fitting Assembly
44.	MS27384-4C	4730-00-057-0665	Fitting Assembly
45.	MS27384-5C	4730-00-007-2197	Fitting Assembly
46.	MS27384-6C	4730-00-128-9819	Fitting Assembly
47.	MS27384-8	4730-00-054-7635	Fitting Assembly
48.	MS27385-4C	4730-00-057-0664	Fitting Assembly
49.	MS27385-6C	4730-00-053-0380	Fitting Assembly

Table D-1. (Sheet 1 of 2)

50.	MS27385-8C	4730-00-119-9854	Fitting Assembly
51.	MS87018-10	4730-00-541-9105	Fitting Assembly
52.	MS87018-12	4730-00-541-1957	Fitting Assembly
53.	MS87018-16	4730-00-585-6212	Fitting Assembly
54.	MS87018-4	4730-00-618-7378	Fitting Assembly
55.	MS87018-6	4730-00-613-1859	Fitting Assembly
56.	MS87018-8	4730-00-632-2002	Fitting Assembly
57.	MS87019-12	4730-00-618-7382	Fitting Assembly
58.	MS87019-4	4730-00-709-3887	Fitting Assembly
59.	MS87019-8	4730-00-684-6394	Fitting Assembly
60.	MS87020-10	4730-00-919-6785	Fitting Assembly
61.	MS87020-12	4730-00-238-5338	Fitting Assembly
62.	MS87020-4	4730-00-618-8862	Fitting Assembly
63.	MS87020-6	4730-00-720-1166	Fitting Assembly
64.	MS87020-8	4730-00-795-0945	Fitting Assembly
65.	MS87021-16	4730-00-936-2364	Fitting Assembly
66.	MS87022-16	4730-00-087-1016	Fitting Assembly
67.	MS87023-16	4730-00-403-0886	Fitting Assembly
68.	624-7	5640-00-684-4153	Fire Sleeving
69.	AE102-8	5640-00-568-4687	Fire Sleeving
70.	900902-4	4730-00-675-2450	Clamp
71.	AE10187-001	8030-00-907-0879	Adhesive
72.	QQ-V-423	9505-00-804-3814	Safety Wire .042 Dia.
73.	MS87021- 12	4730-00-936-2365	Fitting Assembly
74.	MS87023-12	4730-00-087-1008	Fitting Assembly
75.	MS87019-10	473-00-813-6923	Fitting Assembly

Table D-1. (Sheet 2 of 2)

Hose Assembly Part Number	Items Required for Fabrication (Refer to Table D-1 for Items Listed)
MS8000E072A	4, 21
MS8000E150B	4, 21, 32
MS8000E160A	4, 21
MS8000E160B	4, 21, 32
MS8000E165A	4, 21
MS8000E180B	4, 21, 32
MS8000E200A	4, 21
MS8000E210C	4, 21, 34
MS8000E250C	4, 21, 34
MS8000E300A	4, 21
MS8000E320E170	32, 4
MS8000E324C	4, 21, 34
MS8000E340C	4, 21, 34
MS8000G070C	6, 22, 35
MS8000G090C	6, 22, 35
MS8000G110B	6, 22, 33
MS8000G130A	6, 22
MS8000G130B	6, 22, 35
MS8000G180C	6, 22, 35
MS8000G520F	6, 35
MS8000H210A	7, 23
MS8000J190F	1, 28
MS8000J220C	1, 17, 28
MS8000J260F	1, 28
MS8000K130B	2, 19, 26
MS8000K130C	2, 19, 30
MS8000K150E180	2, 26, 30
MS8000K160F180	2, 30
MS8000K700C	2, 19, 30
MS8000M210G	3, 20
MS8001E140B	4, 38, 44
MS8001E150B	4, 38, 44
MS8001E200A	4, 38

MS8001E210A	4, 38
MS8001E440A	4, 38
MS8001F150B	5, 39, 45
MS8001F200A	5, 39
MS8001F210A	5, 39
MS8001G130B	6, 40, 46
MS8001G146A	6, 40
MS8001G400A	6, 40
MS8001G440A	6, 40
MS8001H094C	69, 70, 71
MS8001H136H	7, 41, 47
MS87028E123A	12, 54
MS87028E216A	4, 54
MS87028E220C	12, 54, 62
MS87028G082C00	13, 55, 63
MS87028G210A	13, 55
MS87028H090A	14, 56
MS87028H106A000	14, 56
MS87028H110C	14, 56, 64
MS87028H150A	14, 56
MS87028H175A	14, 56
MS87028H280C	14, 56, 64
MS87028H283C000	14, 56, 64
MS87028H700C	14, 56, 64
MS87028J136A	9, 51
MS87028J166F	9, 60
MS87028J185F000	9, 60
MS87028J336C	9, 51, 60
MS87028K116C	10, 73, 74
MS87028K146A	10, 52
MS87028K171B	10, 52, 57
MS87028K214A	10, 52
MS87028K219A	10, 52
MS87028K322E140	10, 57, 61
MS87028K360C	10, 52, 61
MS87028M284E220	11, 66, 67
70-009F245Z347	12, 58, 62, 69, 70, 71

Table D-2.



TUBE ASSY PART NO.	FABRICATE FROM NSN	STOCK DIM.			END FITTING				SYSTEM
		O.D.	W.T.	L	NUTNSN	QTY	SLEEVE NSN	QTY	
204-040-215-27	4710-00-278-8726	3/8	.035	13	4730-00-142-2167	2	4730-00-595-3102	2	Lub.
204-040-722-1	4710-00-278-3291	1/4	.035	16	4730-00-222-1912	2	4730-00-278-0678	2	Lub.
204-040-723-1	4710-00-278-3291	1/4	.035	16	4730-00-222-1912	2	4730-00-278-0678	2	Lub.
204-060-082-1	4710-00-278-3291	1/4	.020	13	4730-w222-1912	2	4730-00-278-0678	2	Lub.
204-060-098-1	4710-00-278-3291	1/4	.035	7	4730-00-222-1912	2	4730-00-278-0678	2	Lub.
204-070-110-153	4710-00-278-6398	1/4	.035	6	4730-00-287-0289	2	4730-00-302-8641	2	Inst. Air
204-070-110-155	4710-00-278-6398	1/4	.035	7	4730-w-287-0289	2	4730-00-302-8641	2	Inst. Air
204-070-110-3	4710-00-278-6398	1/4	.035	18	4730-00-287-0289	2	4730-00-302-8641	2	Inst. Air
204-070-110-65	4710-00-278-6398	1/4	.035	38	4730-00-287-0289	2	4730-00-302-8641	2	Inst. Air
204-070-110-67	4710-00-278-6398	1/4	.035	38	4730-00-287-0289	2	4730-00-302-8641	2	Inst. Air
204-070-110-7	4710-00-278-6398	1/4	.035	24	4730-00-287-0289	2	4730-00-302-8641	2	Inst. Air
204-070-110-71	4710-00-278-6398	1/4	.055	12	4730-00-287-0289	2	4730-00-302-8641	2	Inst. Air
204-070-134-11	4710-00-278-6398	1/4	.035	30	4730-00-287-0289	2	4730-00-302-8641	2	Inst. Air
204-072-265-1	4710-00-278-6398	1/4	.035	60	4730-00-287-0289	2	4730-00-302-8641	2	Inst. Air
204-072-267-1	4710-00-278-6398	1/4	.035	33	4730-00-287-0289	2	4730-00-302-8641	2	Inst. Air
204-072-268-1	4710-00-278-6398	1/4	.035	49	4730-00-287-0289	2	4730-00-302-8641	2	Inst. Air
204-072-355-1	4710-00-278-6398	1/4	.035	14	4730-00-278-0289	2	4730-00-302-8641	2	Inst. Air
204-072-364-1	4710-00-278-6398	1/4	.035	20	4730-00-278-0289	2	4730-00-302-8641	2	Inst. Air
205-040-142-1	4710-00-278-8742	5/8	.035	16.5	4730-00-287-0290	2	4730-W-277-5358	2	
205-040-143-1	4710-00-278-8742	5/8	.035	22.0	4730-00-287-0290	2	4730-00-277-5358	2	
205-040-144-1	4710-00-278-8742	5/8	.035	58.0	4730-00-287-0290	2	4730-00-277-5358	2	
205-040-145-1	4710-00-278-8742	5/8	.035	3.5	4730-00-287-0290	2	4730-00-277-5358	2	
205-040-146-1	4710-00-278-8742	5/8	.035	40.5	4730-00-287-0290	2	4730-00-277-5358	2	
205-040-147-1	4710-00-278-8742	5/8	.035	21.5	4730-00-287-0290	2	4730-00-277-5358	2	
205-040-148-1	4710-00-278-8742	5/8	.035	16.0	4730-00-287-0290	2	4730-00-277-5358	2	

Table D-3. (Sheet 1 of 6)

TUBE ASSY PART NO.	FABRICATE FROM NSN	STOCK DIM.			END FITTING				SYSTEM
		O.D.	W.T.	L	NUT NSN	QTY	SLEEVE NSN	QTY	
205-040-150-1	4710-00-279-0955	3/8	.035	9.8	4730-00-142-2167	2	4730-00-595-3102	2	
205-040-151-1	4710-00-279-0955	3/8	.035	3.5	4730-00-142-2167	2	4730-00-595-3102	2	
205-040-159-1	4710-00-278-8742	5/8	.035	23.5	4730-00-287-0290	2	4730-00-277-5358	2	
205-060-424-1	4710-00-278-2908	3/4	.035	3 7/8	4730-00-287-0296	2	4730-00-433-3377	2	Pneu.
205-060-440-1	4710-00-541-8624	1/2	.035	14	4730-00-287-0297	2	4730-00-433-3376	2	Pneu.
205-060-580-1	4710-00-278-2908	3/8	.035	38	4730-00-142-2167	1	4730-00-595-3102	1	Drain
205-060-581-1	4710-00-278-8726	3/8	.035	69	4730-00-142-2167	1	4730-00-595-3102	1	Drain
205-060-582-1	4710-00-278-8745	3/4	.035	73	4730-00-287-0285	1	4730-00-287-0067	1	Drain
205-060-583-1	4710-00-278-6398	1/4	.035	49	4730-00-287-0289	1	4730-00-302-8641	1	Drain
205-040-203-1	4710-00-277-3627	3/4	.035	36	4730-00-287-0285	2	4730-00-237-0067	2	
UH-1-L0001-1	4710-00-278-8745	3/4	.035	42	4730-00-287-0285	1	4710-00-287-0067	1	Drain
UH-1-L0001-2	4710-00-278-8745	3/4	.035	36	4730-00-287-0285	1	4710-00-287-0067	1	Drain
204-040-215-19	4710-00-278-8726	3/8	.035	10.5	4730-00-142-2167	2	4730-00-595-3102	2	Lube

D-68.2 Change 8

TUBE ASSY PART NO.	FABRICATE FROM NSN	STOCK DIM.			END FITTING				SYSTEM
		O.D.	W.T.	L	NUT NSN	QTY	SLEEVE NSN	QTY	
205-060-584-1	4710-00-278-8745	3/4	.035	43	4730-00-287-0285	2	4730-00-287-0067	2	Lub.
205-060-585-1	4710-00-278-8745	3/4	.035	16	4730-00-287-0285	2	4730-00-287-0067	2	Lub.
205-060-586-1	4710-00-278-8742	5/8	.035	46	4730-00-287-0295	2	4730-00-277-5358	2	Lub.
205-060-587-1	4710-00-278-8742	5/8	.035	40	4730-00-287-0295	2	4730-00-277-5358	2	Lub.
205-060-589-1	4710-00-278-8726	3/8	.035	14	4730-00-142-2167	1	4730-00-278-6070	1	Drain
205-060-590-1	4710-00-278-8726	3/8	.035	50	4730-00-142-2167	1	4730-00-278-6070	1	Drain
205-060-591-1	4710-00-278-3282	3/8	.035	9	4730-00-203-3831	2	4730-00-595-3102	2	Lub.
205-060-592-1	4710-00-278-3282	3/8	.035	17	4730-00-203-3831	2	4730-00-595-3102	2	Lub.
205-060-593-1	4710-00-278-3282	3/8	.035	33	4730-00-203-3831	2	4730-00-595-3102	2	Lub.
205-060-594-1	4710-00-278-3314	3/4	.035	39	4730-00-287-0296	2	4730-00-433-3377	2	Lub.
205-060-648-1	4710-00-278-8742	5/8	.035	36	4710-00-287-0290	2	4730-00-277-5358	2	Fuel
205-060-649-1	4710-00-278-8742	5/8	.035	36	4710-00-287-0290	2	4730-00-277-5358	2	Fuel
205-060-690-1	4710-00-278-8726	3/8	.035	46	4730-00-142-2167	1	4730-00-278-6070	1	Drain
205-060-691-1	4710-00-278-8745	3/4	.035	21	4730-00-287-0285	2	4730-00-287-0067	2	Fuel
205-060-692-1	4710-00-278-8745	3/4	.035	11	4730-00-287-0285	2	4730-00-287-0067	2	Fuel
205-060-693-1	4710-00-278-8745	3/4	.035	33	4730-00-287-0285	2	4730-00-287-0067	2	Fuel
205-060-694-1	4710-00-278-8745	3/4	.035	17	4730-00-287-0285	2	4730-00-287-0067	2	Fuel
205-060-695-1	4710-00-278-8723	1	.035	36	4730-00-222-1915	2	4730-00-287-0065	2	Fuel
205-060-696-1	4710-00-278-8723	1	.035	33	4730-00-222-1915	1	4730-00-287-0065	1	Drain
205-060-697-1	4710-00-278-8726	3/8	.035	49	4730-00-142-2167	1	4730-00-278-6070	1	Fuel
205-061-213-1	4710-00-278-8723	1	.035	19	4730-00-222-1915	2	4730-00-287-0065	2	Drain
205-061-214-1	4710-00-278-8723	1	.035	51	4730-00-222-1915	1	4730-00-287-0065	1	Drain
IPS-1	4710-00-278-8723	1	.035	10.5	4730-00-222-1915	2	4730-00-287-0065	2	Drain
IPS-2	4710-00-278-8723	1	.035	3.625	4730-00-222-1915	2	4730-00-287-0065	2	Drain
205-061-600-1	4710-00-278-8742	5/8	.035	20	4730-00-287-0290	2	4730-00-277-5358	2	Fuel
205-061-601-1	4710-00-278-8742	5/8	.035	19	4730-00-287-0290	2	4730-00-277-5358	2	Fuel
205-061-604-1	4710-00-278-6398	1/4	.035	9	4720-00-287-0289	2	4730-00-302-8641	2	Fuel
205-061-606-1	4710-00-279-0950	1/2	.035	20	4730-00-287-0288	2	4730-00-540-6719	2	Fuel
205-061-607-1	4710-00-279-0950	1/2	.035	20	4730-00-287-0288	2	4730-00-540-6719	2	Fuel
205-061-608-1	4710-00-279-0950	1/2	.035	6	4730-00-287-0288	2	4730-00-540-6719	2	Fuel
205-061-609-1	4710-00-279-0950	1/2	.035	5	4730-00-287-0288	2	4730-00-540-6719	2	Fuel
205-061-610-1	4710-00-278-8726	3/8	.035	33	4730-00-142-2167	2	4730-00-278-6070	2	Fuel

Table D-3. (Sheet 2 of 6)

TUBE ASSY PART NO.	FABRICATE FROM NSN	STOCK DIM.			END FITTING				SYSTEM
		O.D.	W.T.	L	NUT NSN	QTY	SLEEVE NSN	QTY	
205-061-611-1	4710-00-278-8726	3/8	.035	33	4730-00-142-2167	2	4730-00-278-6070	2	Fuel
205-061-612-1	4710-00-278-8726	3/8	.035	26	4730-00-142-2167	2	4730-00-278-6070	2	Fuel
205-061-614-1	4710-00-279-0950	1/2	.035	18	4730-00-287-0288	1	4730-00-277-5373	1	Fuel
205-061-615-1	4710-00-279-0950	1/2	.035	17	4730-00-287-0288	1	4730-00-277-5373	1	Drain
205-061-616-1	4710-00-279-0950	1/2	.035	18	4730-00-287-0288	1	4730-00-277-5373	1	Drain
205-061-617-1	4710-00-279-0590	1/2	.035	17	4730-00-287-0288	1	4730-00-277-5373	1	Drain
205-061-618-1	4710-00-278-6398	1/4	.035	13	4730-00-287-0289	1	4730-00-302-8641	1	Drain
205-061-619-1	4710-00-278-6398	1/4	.035	14	4730-00-287-0289	1	4730-00-302-8641	1	Drain
205-061-624-1	4710-00-278-8726	3/8	.035	20	4730-00-142-2167	2	4730-00-278-6070	2	Fuel
205-061-645-1	4710-00-279-0950	1/2	.035	11	4730-00-287-0288	2	4730-00-277-5373	2	Fuel
205-061-647-1	4710-00-278-8742	5/8	.035	21	4730-00-287-0290	2	4730-00-277-5358	2	Fuel
205-061-649-1	4710-00-278-8742	5/8	.035	22	4730-00-287-0290	2	4730-00-277-5358	2	Fuel
205-061-650-1	4710-00-278-8742	5/8	.035	21	4730-00-287-0290	2	4730-00-277-5358	2	Fuel
205-061-651-1	4710-00-279-0950	1/2	.035	23	4730-00-287-0288	1	4730-00-277-5373	1	Drain
205-061-652-1	4710-00-279-0950	1/2	.035	23	4730-00-287-0288	1	4730-00-277-5373	1	Drain
205-061-653-1	4710-00-278-6398	1/4	.035	24	4730-00-287-0289	1	4730-00-302-8641	1	Drain
205-061-654-1	4710-00-278-6398	1/4	.035	23	4730-00-287-0289	1	4730-00-302-8641	1	Drain
205-061-655-1	4710-00-278-8726	3/8	.035	28	4730-00-142-2167	2	4730-00-278-6070	2	Fuel
205-061-659-1	4710-00-279-0950	1/2	.035	14	4730-00-287-0288	2	4730-00-277-5373	2	Fuel
205-061-661-1	4710-00-278-8726	3/8	.035	25	4730-00-142-2167	2	4730-00-278-6070	2	Fuel
205-061-662-1	4710-00-278-8726	3/8	.035	13	4730-00-142-2167	2	4730-00-278-6070	2	Fuel
205-061-663-1	4710-00-279-0950	1/2	.035	30	4730-00-287-0288	2	4730-00-277-5373	2	Fuel
205-061-664-1	4710-00-279-0950	1/2	.035	16	4730-00-287-0288	2	4730-00-277-5373	2	Fuel
205-061-668-1	4710-00-279-0950	1/2	.035	13	4730-00-287-0288	2	4730-00-277-5373	2	Pneu.
205-061-669-1	4710-00-279-0950	1/2	.035	16	4730-00-287-0288	2	4730-00-277-5373	2	Pneu.
205-061-670-1	4710-00-279-0950	1/2	.035	36	4730-00-287-0288	2	4730-00-277-5373	2	Pneu.
205-061-671-1	4710-00-279-0950	1/2	.035	32	4730-00-287-0288	2	4730-00-277-5373	2	Pneu.
205-061-674-1	4710-00-278-3305	5/8	.035	12	4730-00-287-0295	2	4730-00-277-5357	2	Fuel
205-061-675-1	4710-00-278-3282	3/8	.035	12	4730-00-203-3831	2	4730-00-595-3102	2	Fuel
205-061-685-1	4710-00-278-6398	1/4	.035	24	4730-00-287-0289	2	4730-00-302-8641	2	Fuel

Table D-3. (Sheet 3 of 6)



TUBE ASSY PART NO.	FABRICATE FROM NSN	STOCK DIM.			END FITTING			QTY	SYSTEM
		O.D.	W.T.	L.	NUT NSN	QTY	SLEEVE NSN		
205-062-614-1	4710-00-279-0950	1/2	.035	26	4730-00-287-0288	2	4730-00-277-5373	2	Fuel
205-062-662-1	4710-00-278-8726	3/8	.035	9	4730-00-142-2167	2	4730-00-278-6078	2	Fuel
205-062-663-1	4710-00-278-8726	3/8	.035	30	4730-00-142-2167	2	4730-00-278-6078	2	Fuel
205-062-680-1	4710-00-279-0950	1/2	.035	20	4730-00-278-0288	2	4730-00-277-5373	2	Fuel
205-062-681-1	4710-00-279-0950	1/2	.035	25	4730-00-278-0288	2	4730-00-277-5373	2	Fuel
205-070-365-1	4730-00-278-6398	1/4	.035	33	<b>4730-00-287-0289</b>	2	4730-00-302-8641	2	Pneu.
205-070-366-1	4730-00-278-6398	1/4	.035	13	<b>4730-00-287-0289</b>	2	4730-00-302-8641		Pneu.
205-070-436-1	4710-00-278-6398	1/4	.035	24	4730-00-287-0289	2	4730-00-302-8641	2	Pneu.
205-070-439-1	4710-00-278-6398	1/4	.035	14	4730-00-287-0289	2	4730-00-302-8641	2	Fuel
205-070-440-1	4710-00-278-6398	1/4	.035	33	4730-00-287-0289	2	4730-00-302-8641	2	Fuel
205-070-441-1	4710-00-278-6398	1/4	.035	12	4730-00-287-0289	2	4730-00-302-8641	2	Fuel
205-070-448-1	4710-00-278-6398	1/4	.035	10	4730-00-287-0289	2	4730-00-302-8641	2	Fuel
205-070-475-1	4710-00-278-6398	1/4	.035	36	4730-00-287-0289	2	4730-00-302-8641	2	Fuel
205-070-476-1	4710-00-278-6398	1/4	.035	12	4730-00-287-0289	2	4730-00-302-8641	2	Fuel
205-070-484-1	4710-00-278-6398	1/4	.035	18	4730-00-287-0289	2	4730-00-302-8641	2	Pneu
205-070-485-1	4710-00-278-6398	1/4	.035	10	4730-00-287-0289	2	4730-00-302-8641	2	Inst. Air
205-070-486-1	4710-00-278-6398	1/4	.035	23	4730-00-287-0289	2	4730-00-302-8641	2	Pneu.
205-070-487-1	4710-00-278-6398	1/4	.035	36	4730-00-287-0289	2	4730-00-302-8641	2	Pneu.
205-070-488-1	4710-00-278-6398	1/4	.035	12	4730-00-287-0289	2	4730-00-302-8641	2	Pneu.
205-070-490-1	4710-00-278-6398	1/4	.035	34	4730-00-287-0289	2	4730-00-302-8641	2	Pneu.
205-070-491-1	4710-00-278-6398	1/4	.035	39	4730-00-287-0289	2	4730-00-302-8641	2	Pneu.
205-072-208-1	4730-00-278-6398	1/4	.035	46	<b>4730-00-287-0289</b>	2	4730-00-302-8641	2	Pneu.
205-072-278-1	4710-00-278-6398	1/4	.035	32	4730-00-287-0289	2	4730-00-302-8641	2	Pneu.
205-072-304-1	4730-00-278-6398	1/4	.035	13	<b>4730-00-287-0289</b>	2	4730-00-302-8641	2	Pneu.
205-072-305-1	4730-00-278-6398	1/4	.035	15	<b>4730-00-287-0289</b>	2	4730-00-302-8641	2	Pneu.
205-072-410-1	4710-00-278-8723	1	.035	28	4730-00-222-1915	2	4730-00-287-0065	2	Pneu.
205-072-424-1	4710-00-278-8723	1	.035	66	4730-00-222-1915	2	4730-00-287-0065	2	Pneu.
205-075-134-1	4710-00-278-8726	3/8	.035	7	N/A	N/A	N/A	N/A	Drain
205-076-033-1	4710-00-278-6398	1/4	.035	16	4730-00-555-8203	2	4730-00-289-8619	2	Hyd.
205-076-131-1	4710-00-278-8726	3/8	.035	32	4730-00-554-7397	2	4730-00-554-7398	2	Hyd.

Table D-3. (Sheet 4 of 6)

**TM 55-1520-210-23-3**

TUBE ASSY PART NO.	FABRICATE FROM NSN	STOCK DIM.			END FITTING			QTY	SYSTEM
		O.D.	W.T.	L	NUT NSN	QTY	SLEEVE NSN		
205-076-136-1	4710-00-278-6398	¼	.035	30	4730-00-555-8203	2	4730-00-289-8619	2	Hyd.
205-076-138-1	4710-00-279-0950	½	.035	16	4730-00-555-0595	2	4730-00-580-2120	2	Hyd.
205-076-140-1	4710-00-278-8726	3/8	.035	33	4730-00-554-7397	2	4730-00-554-7398	2	Hyd.
205-076-141-1	4710-00-278-3282	3/8	.035	26	4730-00-810-449	2	4730-00-554-7398	2	Hyd.
205-076-156-1	4710-00-278-6398	¼	.035	33	4730-00-555-8203	2	4730-00-289-8619	2	Hyd.
205-076-137-1	4710-00-278-8726	3/8	.035	17	4730-00-554-7397	2	4730-00-554-7398	2	Hyd.
205-076-158-1	4710-00-278-8726	3/8	.035	24	4730-00-554-7397	2	4730-00-554-7398	2	Hyd.
205-076-159-1	4710-00-279-0950	1/2	.035	28	4730-00-555-0595	2	4730-00-580-2120	2	Hyd.
205-076-160-1	4710-00-278-6398	1/4	.035	29	4730-00-555-8203	2	4730-00-289-8619	2	Hyd.
205-076-161-1	4710-00-278-6398	1/4	.035	13	4730-00-555-8203	2	4730-00-289-8619	2	Hyd.
205-076-200-1	4710-00-278-6398	1/4	.035	9.0	4730-00-555-8203	2	4730-00-289-8619	2	Hyd.
205-076-201-1	4710-00-278-8726	3/8	.035	15	4730-00-554-7397	2	4730-00-554-7398	2	Hyd.
205-076-202-1	4710-00-278-8726	3/8	.035	15	4730-00-554-7397	2	4730-00-554-7398	2	Hyd.
205-076-203-1	4710-00-278-8726	3/8	.035	12	4730-00-554-7397	2	4730-00-554-7398	2	Hyd.
205-076-204-1	4710-00-278-8726	3/8	.035	24	4730-00-554-7397	2	4730-00-554-7398	2	Hyd.
205-076-205-1	4710-00-278-6398	1/4	.035	15.0	4730-00-555-8203	2	4730-00-289-8619	2	Hyd.
205-076-206-1	4710-00-278-6398	1/4	.035	19	4730-00-555-8203	2	4730-00-289-8619	2	Hyd.
205-076-207-1	4710-00-278-3291	¼	.035	16	4730-00-554-8015	2	4730-00-289-8619	2	Hyd.
205-076-208-1	4710-00-278-6398	¼	.035	40.0	4730-00555-8203	2	4730-00-289-8619	2	Hyd.
205-076-209-1	4710-00-278-6398	¼	.035	35	4730-00-555-8203	2	4730-00-289-8619	2	Hyd.
205-076-210-1	4710-00-278-3291	¼	.035	14	4730-00-554-8015	2	4730-00-289-8619	2	Hyd.
205-076-212-1	4710-00-278-3282	3/8	.035	26	4730-00-810-4499	2	4730-00-554-7398	2	Hyd.
205-076-213-1	4710-00-278-8726	3/8	.035	34	4730-00-554-7397	2	4730-00-554-7398	2	Hyd.
205-076-214-1	4710-00-278-8726	3/8	.035	18	4730-00-554-7397	2	4730-00-554-7398	2	Hyd.
205-076-215-1	4710-00-278-8726	¼	.035	30.0	4730-00554-7397	2	4730-00-554-7398	2	Hyd.
205-076-216-1	4710-00-278-8726	3/8	.035	20	4730-00-554-7397	2	4730-00-554-7398	2	Hyd.
205-076-217-1	4710-00-278-8726	3/8	.035	24	4730-00-554-7397	2	4730-00-554-7398	2	Hyd.
205-076-221-1	4710-00-278-6398	¼	.035	52.0	4730-00-565-8203	2	4730-00-289-8619	2	Hyd.
205-076-223-1	4710-00-278-6398	¼	.035	12	4730-00-555-8203	2	4730-00-289-8619	2	Hyd.

Table D-3. (Sheet 5 of 6)

TUBE ASSY PART NO.	FABRICATE FROM NSN	STOCK DIM.			END FITTING			QTY	SYSTEM
		O.D.	W.T.	L	NUT NSN	QTY	SLEEVE NSN		
205-076-227-1	4710-00-278-8726	3/8	.035	33.0	4730-00-554-7397	2	4730-00-554-7398	2	Hyd.
205-076-231-1	4710-00-279-0950	1/2	.035	25.0	4730-00-555-0595	2	4730-00-580-2120	2	Hyd.
205-076-232-1	4710-00-278-8726	3/8	.035	18.0	4730-00-554-7397	2	4730-00-554-7398	2	Hyd.
205-076-233-1	4710-00-278-6398	1/4	.035	43	4730-00-555-8203	1	4730-00-289-8619	1	Drain
205-076-235-1	4710-00-684-5074	3/8	.035	34	4730-00-554-7397	2	4730-00-554-7398	2	Hyd.
205-076-236-1	4710-00-278-8726	3/8	.035	12	4730-00-554-7397	2	4730-00-554-7398	2	Hyd.
205-076-237-1	4710-00-278-8726	3/8	.035	12	4730-00-554-7397	2	4730-00-554-7398	2	Hyd.
205-076-238-1	4710-00-278-8726	3/8	.035	22	4730-00-554-7397	2	4730-00-554-7398	2	Hyd.
205-076-240-1	4710-00-278-8726	3/8	.035	40	4730-00-554-7397	2	4730-00-554-7398	2	Hyd.
205-076-241-1	4710-00-278-8726	3/8	.035	31	4730-00-554-7397	2	4730-00-554-7398	2	Hyd.
205-076-242-1	4710-00-278-8726	3/8	.035	33	4730-00-554-7397	2	4730-00-554-7398	2	Hyd.
205-076-244-1	4710-00-278-8726	3/8	.035	25	4730-00-554-7397	2	4730-00-554-7398	2	Hyd.
205-076-245-1	4710-00-278-8726	3/8	.035	25	4730-00-554-7397	2	4730-00-554-7398	2	Hyd.
205-076-246-1	4710-00-278-8726	3/8	.035	23	4730-00-554-7397	2	4730-00-554-7398	2	Hyd.
205-076-247-1	4710-00-278-8726	3/8	.035	23	4730-00-554-7397	2	4730-00-554-7398	2	Hyd.
205-076-248-1	4710-00-278-8726	3/8	.035	33	4730-00-554-7397	2	4730-00-554-7398	2	Hyd.
205-076-249-1	4710-00-278-8726	3/8	.035	33	4730-00-554-7397	2	4730-00-554-7398	2	Hyd.
205-076-250-1	4710-00-278-8726	3/8	.035	27	4730-00-554-7397	2	4730-00-554-7398	2	Hyd.
205-076-251-1	4710-00-278-8726	3/8	.035	21	4730-00-554-7397	2	4730-00-554-7398	2	Hyd.
205-076-252-1	4710-00-278-8726	3/8	.035	21	4730-00-554-7397	2	4730-00-554-7398	2	Hyd.
205-076-253-1	4710-00-278-8726	3/8	.035	27	4730-00-554-7397	2	4730-00-554-7398	2	Hyd.
205-076-254-1	4710-00-278-6398	1/4	.035	8	4730-00-555-8203	2	4730-00-289-8619	2	Hyd.
205-076-255-1	4710-00-278-6398	1/4	.035	8	4730-00-555-8203	2	4730-00-289-8619	2	Hyd.
205-076-257-1	4710-00-278-8726	3/8	.035	17	4730-00-554-7397	2	4730-00-554-7398	2	Hyd.
205-076-258-1	4710-00-684-7029	1/2	.035	22	4730-00-554-8018	2	4730-00-580-2120	2	Hyd.
205-076-259-1	4710-00-279-0950	1/2	.035	36	4730-00-555-0595	2	4730-00-580-2120	2	Hyd.
99C29	4710-00-278-6398	1/4	.035	11	4730-00-287-0289	2	4730-00-302-8641	2	Pneu.
99C30	4710-00-278-6398	1/4	.035	17	4730-00-287-0289	2	4730-00-302-8641	2	Pneu.

Table D-3. (Sheet 6 of 6)

PART NUMBER	BEND NO.	DIMENSION "A" FROM "Y" END	BEND RADIUS	DIAL SETTING	BEND ANGLE	END FITTING AND NOTES
		DIMENSION "B"	TYPE END "Y"	TYPE END "X"	PRESSURE TEST	
205-040-159-1	1	1.19	1.5	0	80	Y - AN318-10D MS20819-10D X - AN818-10D MS20819-10D
	2	16.12	1.5	273	73	
		23.50	I	I	N/A	
204-040-215-19	1	8.88	1.00	0	90	Y - AN818-6D AN819-6Z X - AN818-6D AN819-6Z
	2	5.62	1.00	0	90	
204-040-215-27	1	2 7/8	15/16	0	90	Y - AN818-6D MS20819-6D X - AN818-6D MS20819-6D
	2	7	15/16	90	22	
		10 3/8	III	III	N/A	
205-040-722-1	1	1	9/16	0	21	Y - AN818-4 MS20819-4 X - AN818-4 MS20819-4
	2	2 3/8	9/16	190	22	
	3	6 3/4	9/16	210	30	
	4	11 1/2	9/16	210	27	
		14	I	I	125 psi	
204-040-723-1	1	2 1/4	9/16	0	34	Y - AN818-4 MS20819-4 X - AN818-4 MS20819-4
	2	5	9/16	348	22	
	3	8 7/8	9/16	340	16	
		14	I	I	125 psi	
204-060-082-1	1	1 1/8	9/16	0	90	Y - AN818-4 MS20819-4 X - AN818-4 MS20819-4
	2	6 13/16	9/16	90	60	
		13	I	I	N/A	
204-060-098-1	1	1	9/16	90	0	Y - AN818-4 MS20819-4 X - AN818-4 MS20819-4
	2	3	9/16	45	270	
		7	I	I	I	
					N/A	
204-070-110-153	1	1	9/16	0	110	Y - AN818-4D MS20819-4D X - AN818-4D MS20819-4D
		3 3/4	III	III	35 psi	
204-070-110-155	1	1 5/8	9/16	0	45	Y - AN818-4D MS20819-4D X - AN818-4D MS20819-4D
		4 13/16	III	III	N/A	
204-070-110-3	1	2 3/16	9/16	0	79	Y - AN818-4D MS20819-4D X - AN818-4D MS20819-4D
	2	3 7/8	9/16	180	79	
	3	13 1/16	9/16	280	90	
		15 3/8	III	III	N/A	
204-070-110-7	1	1 5/8	9/16	0	55	Y - AN818-4D MS20819-4D X - AN818-4D MS20819-4D
	2	4 1/4	9/16	180	60	
	3	16 3/4	9/16	180	60	
	4	19 1/2	9/16	0	55	
		21 1/2	III	III	N/A	
204-070-110-65	1	1 9/16	9/16	0	70	Y - AN818-4D MS20819-4D X - AN818-4D MS20819-4D
	2	3 3/8	9/16	180	70	
	3	6 1/8	9/16	0	45	
	4	7 1/2	9/16	180	45	
	5	30 1/8	9/16	0	45	
	6	33 3/4	9/16	265	60	
		35 5/8	III	III	N/A	
204-070-110-67	1	1 9/16	9/16	0	70	Y - AN818-4D MS20819-4D X - AN818-4D
	2	3 3/8	9/16	180	70	
	3	6 1/8	9/16	0	45	

Table D-4. (Sheet 1 of 20)

PART NUMBER	BEND NO.	DIMENSION "A" FROM "Y" END	BEND RADIUS	DIAL SETTING	BEND ANGLE	END FITTING AND NOTES
		DIMENSION "B"	TYPE END "Y"	TYPE END "X"	PRESSURE TEST	
	4	7½	9/16	180	45	MS20819-4D
	5	30%	9/16	0	45	
	6	33%	9/16	95	60	
		35%	III	III	N/A	
204-070-110-71	1	1 11/16	9/16	0	125	Y - AN818-4D MS20819-4D X - AN818-4D MS20819-4D
	2	3 15/16	9/16	160	35	
		9 11/16	III	III	N/A	
204-070-134-11	1	1 11/16	9/16	0	86	Y - AN818-4D MS20819-4D X - AN818-4D MS20819-4D
	2	4 5/16	9/16	102	79	
	3	19 1/16	9/16	235	70	
	4	22 13/16	9/16	55	72	
		27 5/16	III	III	N/A	
204-072-265-1	1	55.1	.56	0	88	Y - AN818-4D MS20819-4D X - AN818-4D MS20819-4D
	2	52.6	.56	183	92	
	3	44.5	.56	57	88	
	4	41.8	.56	327	33	
	5	10.1	.56	292	53	
	6	8.5	.56	71	29	
	7	2.7	.56	219	24	
	8	1.5	.56	45	18	
204-072-267-1	1	2 3/16	9/16	0	102	Y - AN818-4D MS20819-4D X - AN818-4D MS20819-4D
	2	13%	9/16	270	25	
	3	28%	9/16	24	33	
		30 15/16	III	III	N/A	
204-072-268-1	1	43.6	.56	0	85	Y - AN818-4D MS20819-4D X - AN818-4D MS20819-4D
	2	40.83	.56	91	37	
	3	9.0	.56	82	41	
		46%	III	III	35 psi	
204-072-355-1	1	11%	9/16	0	77	Y - AN818-4D NAS20819-4D X - AN818-4D NAS20819-4D
	2	10%	9/16	180	74	
	3	8 3/16	9/16	270	56	
	4	5%	9/16	200	67	
		14	II		35 psi	
204-072-364-1	1	16 1/16	9/16	0	140	Y - AN818-4D NAS20819-4D X - AN818-4D MS20819-4D
	2	13 7/16	9/16	0	35	
	3	1 5/16	9/16	260	24	
		20	I	I	N/A	
205-060-424-1	N/A	(STRAIGHT TUBE)				Y - AN818-12 MS20819-12 X - AN818-12 MS20819-12
		3%	I	I	100 psi	
205-060-440-1	1	1 5/16	1¼	0	97	Y - AN818-8 MS20819-8 X - AN818-8 MS20819-8
	2	9 5/16	1¼	125	11	
		11 29/32	I	I	100 psi	
205-060-580-1	1	1%	1	0	83	Y - AN818-6D MS20819-6D X - Scarf Dial
	2	4%	1	90	5	
	3	18 3/16	1	20	46	

Table d-4. (Sheet 2 of 20)

PART NUMBER	BEND NO.	DIMENSION "A" FROM "Y" END	BEND RADIUS	DIAL SETTING	BEND ANGLE	END FITTING AND NOTES
		DIMENSION "B"	TYPE END "Y"	TYPE END "X"	PRESSURE TEST	
	4	21 1/4	1	205	46	Setting 220
		35 7/8	V	III	N/A	
205-060-581-1	1	2	1	0	6	Y - AN818-6D MS20819-6D X - Scarf Dial Setting 320
	2	5	1	300	80	
	3	10 3/4	1	40	55	
	4	17 3/4	1	62	40	
	5	20 3/4	1	255	27	
	6	26 1/6	1	100	81	
	7	53	1	350	52	
	8	61 11/16	1	140	74	
		66 11/16	V	III	N/A	
205-060-582-1	1	3 3/4	1 3/4	0	83	Y - AN818-12D MS20819-12D X - Scarf Dial Setting 60
	2	11 3/4	1 3/4	90	56	
	3	21 3/4	1 3/4	90	39	
	4	29	1 3/4	165	73	
	5	55 3/4	1 3/4	60	54	
	6	65 1/4	1 3/4	240	76	
		71	V	I	N/A	
205-060-583-1	1	1 1/2	9/16	0	55	Y - AN818-4D MS20819-4D X - Scarf Dial Setting 110
	2	4	9/16	180	55	
	3	9 3/4	9/16	90	50	
	4	13 1/4	9/16	90	34	
	5	15 1/4	9/16	270	54	
	6	34 7/8	9/16	110	26	
	7	42 1/4	9/16	290	47	
		46 1/2	V	III	N/A	
205-060-584-1	1	2 3/4	1 3/4	0	87	Y - AN818-12D MS20819-12D X - AN818-12D MS20819-12D
	2	12	1 3/4	265	34	
	3	26 15/16	1 3/4	262	94	
	4	36 1/4	1 3/4	345	8	
		40	I	I	100 psi	
205-060-585-1	1	2 5/16	1 3/4	0	90	Y - AN818-12D MS20819-12D X - AN818-12D MS20819-12D
	2	9 3/16	1 3/4	270	15	
		13 3/16	I	I	100 psi	
205-060-586-1	1	3 1/4	1 1/2	0	90	Y - AN818-10D MS20819-10D X - AN818-10D MS20819-10D
	2	18 3/4	1 1/2	90	90	
	3	25 3/4	1 1/2	180	88	
	4	36 3/4	1 1/2	0	61	
	5	40 3/4	1 1/2	0	26	
		43 3/4	I	I	100 psi	
205-060-587-1	1	2 3/4	1 1/2	0	88	Y - AN818-10D MS20819-10D X - AN818-10D MS20819-10D
	2	14 1/4	1 1/2	180	87	
	3	23 3/4	1 1/2	270	88	
	4	33 13/16	1 1/2	0	90	
		37 9/16	I	I	N/A	
205-060-589-1	1	2 7/16	1	0	83	Y - AN818-6D MS20819-6D X - Scarf Dial Setting 81
	2	5 15/16	1	90	67	
	3	8 3/4	1	171	90	
		11 3/4	V	III	N/A	
UH-1-L0001-1	Use as alternate for 205-060-582-1					
UH-1-L0001-2	1	15 1/8	1 3/4	0	54	Y - AN818-12D MS20819-12 X - NONE END X: SCARF 45° 60° from 0°
	2	24 5/8	1 3/4	180	76	
		30 1/2	I	V	NONE	

Table D-4. (Sheet 3 of 20)

PART NUMBER	BEND NO.	DIMENSION "A" FROM "Y" END	BEND RADIUS TYPE END "Y"	DIAL SETTING TYPE END -X-	BEND ANGLE PRESSURE TEST	END FITTING AND NOTES
		DIMENSION B				
205-060-590-1	1	1 1/2	I	0	83	Y - AN818-6D MS20819-6D X - Scarf Dial Setting 235
	2	9 5/8	I	165	85	
	3	14 5/16	I	50	85	
	4	17 1/4	I	230	90	
	5	21 1/4	I	230	25	
	6	24 5/8	I	50	22	
	7	31 1/4	I	155	15	
	8	40 1/2	I	50	37	
	9	42 3/4	I	235	45	
		47 3/8	V	III	N/A	
205-060-591-1	1	1	I	0	80	Y - AN818-6 MS20819-6 X - AN818-6 MS20819-6
		6 5/16	I	I	N/A	
205-060-592-1	1	15/16	I	0	70	Y - AN818-6 MS20819-6 X - AN818-6 MS20819-6
	2	12 7/16	I	75	50	
		14 1/4	I	I	N/A	
205-060-593-1	1	11 1/4	I	0	15	Y - AN818-6 MS20819-6 X - AN818-6 MS20819-6
	2	13 1/4	I	180	15	
	3	15 1/4	I	270	76	
		30 9/16	I	I	N/A	
205-060-594-1	1	2 3/4	1 3/4	0	82	Y - AN818-12 MS20819-12 X - AN818-12 MS20819-12
	2	16. 3/8	1 3/4	210	78	
	3	22 1/2	1 3/4	280	67	
	4	31 3/4	1 3/4	357	52	
		36 1/4	I	I	100 psi	
205-060648-1	1	8 7/16	1 1/2	0	28	Y - AN818-10D MS20819-10D X - AN818-10D MS20819-10D
	2	11 7/16	1 1/2	180	28	
	3	20 1/16	1 1/2	270	8	
	4	28 1/16	1 1/2	180	8	
	5	30 5/16	1 1/2	0	8	
		33 1/16	I	I	35 psi	
205-060649-1	1	8 1/8	1 1/2	0	28	Y - AN818- 10D MS20819-10D x - AN818-10D MS20819-10D
	2	11 1/8	1 1/2	180	28	
	3	19 5/8	1 1/2	290	12	
	4	28 1/8	1 1/2	200	8	
	5	30 5/16	1 1/2	20	8	
		33 7/16	I	I	35 psi	
205-060-690-1	1	2 11/16	I	0	25	Y - AN818-6D MS20819-6D X - Scarf Dial Setting 210
	2	4 3/16	I	180	62	
	3	7 7/16	I	0	32	
	4	26 11/16	I	30	46	
	5	29 7/16	I	210	46	
		43 13/16	III	V	N/A	
205-060-691-1	1	2	1 3/4	0	61	Y - AN818-12D MS20819-12D X- AN818-12D MS20819-12D
	2	6	1 3/4	180	60	
	3	13 5/8	1 3/4	270	12	
	4	16 3/16	1 3/4	90	12	
		18 3/8	I	I	N/A	

Table D-4. (Sheet 4 of 20)

PART NUMBER	BEND NO	DIMENSION -A- FROM "Y" END	BEND RADIUS	DIAL SETTING	BEND ANGLE PRESSURE TEST	END FITTING AND NOTES
		DIMENSION "B"	TYPE END	TYPE EN "X"		
205-070-436-1	1	2 5/16	9/16	0	49	Y - AN818-4D MS20819-1D X - AN818-4D MS20819-4D
	2	4 7/16	9/16	180	49	
	3	15 7/16	9/16	180	90	
	4	18	9/16	330	90	
	5	19 3/8	9/16	60	25	
		21 3/4	III	III	N/A	
205-070-439-1	1	3 1/2	9/16	0	45	Y - AN818-4D MS20819-4D X - AN818-4D MS20819-4D
	2	7 3/16	9/16	180	43	
		11 1/14	III	III	35 psi	
205-070-440-1	1	2 9/16	9/16	0	9	Y - AN818-4D MS20819-4D X - AN818-4D MS20819-4D
	2	17 11/16	9/16	180	8	
		30 15/16	III	III	N/A	
205-070-441-1	1	1 1/16	9/16	0	90	Y - AN818-4D MS20819-4D x - AN818-4D MS20819-4D
	2	3	9/16	0	40	
	3	5 5/16	9/16	180	40	
	4	8	9/16	90	45	
		9 7/8	III	III	35 psi	
205-070-448-1	1	2 3/8	9/16	0	180	Y - AN818-4D MS20819-4D X - AN818-4D MS20819-4D
	2	5 1/8	9/16	180	90	
		7 1/2	III	III	35 psi	
205-070-475-1	1	3 1/2	9/16	0	20	Y - AN818-4D MS20819-4D X - AN818-4D MS20819-4D
	2	7 3/8	9/16	105	83	
	3	9 1/8	9/16	260	62	
	4	11 5/16	9/16	240	88	
	5	13 7/8	9/16	55	86	
	6	17	9/16	328	14	
	7	20 1/8	9/16	148	15	
	8	26 13/16	9/16	53	13	
	9	28 3/8	9/16	233	13	
	33 5/8	III	III	35 psi		
205-070-476-1	1	1 1/8	9/16	0	20	Y - AN818-4D MS20819-4D X - AN818-4D MS20819-4D
	2	2 9/16	9/16	180	25	
		9 3/8	III	III	35 psi	
205-070-484-1	1	1 1/8	9/16	0	52	Y - AN818-4D MS20819-4D X - AN818-4D MS20819-4D
	2	2 3/4	9/16	180	78	
	3	14 1/4	9/16	315	24	
		15 7/8	III	III	150 psi	
205-070-435-1	1	2 3/8	9/16	0	180	Y - AN818-4D MS20819-4D X - AN818-4D MS20819-4D
	2	4 15/16	9/16	180	90	
		7 7/16	III	III	N/A	
205-070-486-1	1	1 3/4	9/16	0	50	Y - AN818-4D MS20819-4D X - AN818-4D
	2	4 1/2	9/16	180	50	
	3	16 3/16	9/16	160	38	

Table D-4. (Sheet 5 of 20)



PART NUMBER	BEND NO.	DIMENSION "A" FROM "Y" END	BEND RADIUS	DIAL SETTING	BEND ANGLE	END FITTING AND NOTES
		DIMENSION "B"	TYPE END "Y"	TYPE END "X"	PRESSURE TEST	
205-060-692-1	1	2 7/16	1 3/4	0	35	Y - AN818-12D MS20819-12D X - AN818-12D MS20819-12D
	2	5 5/8	1 3/4	335	55	
		8 7/8	I	I	N/A	
205-060-693-1	1	7	1 3/4	0	54	Y - AN818-12D MS20819-12D X - AN818-12D MS20819-12D
	2	12 9/16	1 3/4	180	54	
	3	25 7/16	1 3/4	90	12	
	4	27 15/16	1 3/4	270	12	
		30 11/16	I	I	N/A	
205-060-694-1	1	1 3/4	1 3/4	0	30	Y - AN818-12D MS20819-12D X - AN818-12D MS20819-12D
	2	9	1 3/4	90	5	
	3	11 13/16	1 3/4	270	5	
		14	I	I	35 psi	
205-060-695-1	1	1 3/4	3	0	90	Y - AN818-16D MS20819-16D X - AN818-16D MS20819-16D
	2	24 1/16	3	270	41	
	3	29 3/4	3	90	41	
		33 3/4	I	I	35 psi	
205-060-696-1	1	2 3/4	3	0	27	Y - AN818-16D MS20819-16D X - Scarf Dial Setting 96
	2	8 3/16	3	180	24	
	3	18 7/16	3	343	36	
	4	25	3	151	46	
		31	I	V	N/A	
205-060-697-1	1	1 9/16	1	0	50	Y - AN818-6D MS20819-6D X - Scarf Dial Setting 85
	2	4 3/4	1	180	50	
	3	9 1/16	1	90	55	
	4	11 7/16	1	90	26	
	5	13 1/16	1	270	53	
	6	33 9/16	1	100	28	
	7	40 9/16	1	10	9	
	8	44 1/4	1	265	52	
205-061-213-1	1	1 9/16	3	0	85	Y - AN818-16D MS20819-16D X - AN818-16D MS20819-16D
	2	11 1/8	3	90	82	
		16 7/8	I	I	N/A	
205-061-214-1	1	21	3	0	40	Y - AN818-16D MS20819-16D X - Scarf Dial Setting 140
	2	25 1/4	3	180	40	
		49	I	V	N/A	
IPS-1	1	1.75	3	0	110	Y - AN818-16D MS20819-16D X - Scarf Dial Setting 140
IPS-2	N/A	Straight Tube				
205-061-600-1	1	2 1/2	1 1/2	0	90	Y - AN818-10D MS20819-10D X - AN818-10D MS20819-10D
	2	10	1 1/2	90	36	
		17 1/2	I	I	35 psi	
205-061-601-1	1	2 1/4	1 1/2	0	90	Y - AN818-10D MS20819-10D X - AN818-10D MS20819-10D
	2	9 7/8	1 1/2	90	18	
		16 5/16	I	I	35 psi	
205-061-604-1	1	7/16	9/16	0	135	Y - AN818-4D MS20819-4D X - AN818-4D MS20819-4D
	2	3	9/16	180	45	
	3	4 1/4	9/16	270	25	
	4	5 1/2	9/16	90	36	
		6 13/16	III	III	35psi	

Table D-4. (Sheet 6 of 20)

PART NUMBER	BEND NO.	DIMENSION "A" FROM "Y" END	BEND RADIUS	DIAL SETTING	BEND ANGLE	END FITTING AND NOTES
		DIMENSION "B"	TYPE END "Y"	TYPE END "X"	PRESSURE TEST	
205-061-604-101	1	25.78	1.12	0	28.1	A - AN818-6D TYPE MS20819-6 2 B - AN318-6D MS20819-6 2
	2	22.14	1.12	177.0	26.5	
	3	14.37	1.12	174.2	92.8	
	4	10.57	1.12	350.9	88.1	
	5	5.76	1.12	349.9	93.7	
	6	27.15	I	I	35 psi	
205-061-606-1	1	2 7/16	1 1/4	0	24	Y - AN818-8D MS20819-8D X - AN818-8D MS20819-8D
	2	5 11/16	1 1/4	180	24	
		17 1/2	I	I	35 psi	
205-061-607-1	1	3 11/16	1 1/2	0	15	Y - AN818-8D MS20819-8D X - AN818-8D MS20819-8D
	2	11 7/16	1 1/2	180	15	
		17 1/16	I	I	35 psi	
205-061-608-1	N/A	(STRAIGHT TUBE)				Y - AN818-8D MS20819-8D X - AN818-8D MS20819-8D
		3 7/16	I	I	35 psi	
205-061-609-1	N/A	(STRAIGHT TUBE)				Y - AN818-8D MS20819-8D X - AN818-8D MS20819-8D
		2 7/32	I	I	35 psi	
205-061-610-1	1	1 9/16	15/16	0	77	Y - AN818-6D MS20819-6D X - AN818-6D MS20819-6D
	2	8 1/16	15/16	180	77	
		30 3/4	III	III	35 psi	
205-061-611-1	1	3 1/4	1	0	14	Y - AN818-6D MS20819-6D X - AN818-6D MS20819-6D
	2	4 7/8	1	180	105	
	3	14 7/8	1	270	35	
	4	26 11/16	1	90	27	
		30 1/8	III	III	35 psi	
205-061-612-1	1	3 5/8	1	0	8	Y - AN818-6D MS20819-6D X - AN818-6D MS20819-6D
	2	6 11/16	1	90	25	
	3	20 1/8	1	254	23	
		23 9/16	III	III	30 psi	
205-061-614-1	1	1 3/16	1 1/4	0	66	Y - AN818-8D MS20819-8D X - Scarf Dial Setting 210
	2	12	1 1/4	165	81	
		15 1/4	I	V	N/A	
205-061-615-1	1	1 1/16	1 1/4	0	63	Y - AN818-8D MS20819-8D X - Scarf Dial Setting 225
	2	11 3/16	1 1/4	165	78	
		14 1/16	I	V	N/A	
205-061-616-1	1	1 3/16	1 1/4	0	70	Y - AN818-8D MS20819-8D X - Scarf Dial Setting 151
	2	12 3/16	1 1/4	192	85	
		15 1/4	I	V	N/A	
205-061-617-1	1	1 3/8	1 1/4	0	55	Y - AN818-8D MS20819-8D X - Scarf Dial Setting 150
	2	11 3/16	1 1/4	195	76	
		14 1/16	I	V	N/A	

Table D-4. (Sheet 7 of 20)

PART NUMBER	BEND NO.	DIMENSION "A" FROM "Y" END	BEND RADIUS	DIAL SETTING	BEND ANGLE	END FITTING AND NOTES
		DIMENSION "B"	TYPE END "Y"	TYPE END "X"	PRESSURE TEST	
205-061-618-1	1	1 1/16	9/16	0	38	Y - AN818-4D MS20819-4D X - Scarf Dial Setting 220
	2	9 11/32	9/16	180	51	
		10 15/16	III	V	N/A	
205-061-619-1	1	1 1/16	9/16	0	45	Y - AN818-4D MS20819-4D X - Scarf Dial Setting 140
	2	9%	9/16	185	68	
		11%	III	V	N/A	
205-061-624-1	1	1 9/16	I	0	61	Y - AN818-6D MS20819-6D X - AN818-6D MS20819-6D
	2	6%	I	180	18	
		17%	III	III	35 psi	
205-061-645-1	1	1%	1%	0	102	Y - AN818-8D MS20819-8D X - AN818-8D MS20819-81
	2	5%	1%	180	61	
		8%	I	I	35 psi	
205-061-647-1	1	1 5/16	1 1/2	0	25	Y - AN818-10D MS20819-10D X - AN818-10-D MS20819-10D
	2	3%	1 1/2	180	25	
	3	10%	1 1/2	180	23	
	4	14%	1 1/2	0	21	
		18 3/16	I	I	35 psi	
205-061-649-1	1	1%	1 1/2	0	64	Y - AN818-10D MS20819-10D X - AN818-10D MS20819-10D
	2	7%	1 1/2	92	90	
		19 5/16	I	I	35 psi	
205-061-650-1	1	1 3/16	1 1/2	0	63	Y - AN818-10D MS20819-10D X - AN818-10D MS20819-10D
	2	6 7/16	1 1/2	268	90	
		18 9/16	I	I	35 psi	
205-061-651-1	1	1 1/2	1%	0	55	Y - AN818-8D MS20819-8D X - Scarf Dial Setting 19%
	2	7	1%	95	92	
	3	17 1/16	1%	198	94	
		20 5/16	I	V	N/A	
205-061-652-1	1	1%	1%	0	54	Y - AN818-8D MS20819-8D X - Scarf Dial Setting 17%
	2	7	1%	268	88	
	3	17	1%	178	88	
		20%	I	V	N/A	
205-061-653-1	1	2%	9/16	0	28	Y - AN818-4D MS20819-4D X - Scarf Dial Setting 185
	2	8%	9/16	90	84	
	3	18%	9/16	185	87	
		21%	III	V	N/A	
205-061-654-1	1	2 1/2	9/16	0	45	Y - AN828-4D MS20819-4D X - Scarf Dial Setting 180
	2	8%	9/16	270	90	
	3	18 1/2	9/16	180	90	
		21	III	V	N/A	
205-061-655-1	1	2 1/16	I	0	71	Y - AN818-6D MS20819-6D
	2	7 1/16	I	178	70	

Table D-4. (Sheet 8 of 20)

PART NUMBER	BEND NO.	DIMENSION "A" FROM "Y" END	BEND RADIUS	DIAL SETTING	BEND ANGLE	END FITTING AND NOTES
		DIMENSION "H"	TYPE END "Y"	TYPE END "X"	PRESSURE TEST	
	3	14 13/16	I	178	91	X - AN818-6D MS20819-6D
	4	23 3/4	I	90	92	
		26		III	III	
205-061-659-1	1	3 5/8	1 1/4	0	26	Y - AN818-8D MS20819-8D X - AN818-8D MS20819-8D
	2	6 9/16	1 1/4	180	26	
		11 13/16	I	I	60 psi	
205-061-661-1	1	5 1/2	I	0	33	Y - AN818-6D MS20819-6D X - AN818-6D MS20819-6D
	2	7 3/4	I	180	33	
	3	15 1/4	I	197	89	
		22 3/4	III	III	60 psi	
205-061-662-1	1	4 3/4	I	0	90	Y - AN818-6D MS20819-6D X - AN818-6D MS20819-6D
		10 3/4	III	III	60 psi	
205-061-663-1	1	I	1 1/4	0	90	Y - AN818-8D MS20819-8D X - AN818-8D MS20819-8D
	2	11 1/16	1 1/4	0	37	
	3	14 3/4	1 1/4	180	37	
	4	22 3/4	1 1/4	230	62	
	5	25 1/8	1 1/4	50	67	
		27 1/4	I	I	35 psi	
205-061-664-1	N/A	(STRAIGHT TUBE)				Y - AN818-8D MS20819-8D X - AN818-8D MS20819-8D
		13 1/2	I	I	60 psi	
205-061-668-1		1/2				
	1	2 3/4	1 1/4	0	90	Y - AN818-8D MS20819-8D X - AN818-8D MS20819-8D
	2	8 3/4	1 1/4	265	10	
	10 7/8	I	I	80 psi		
205-061-669-1	1	1 7/16	1 1/4	0	83	Y - AN818-8D MS20819-8D X - AN818-8D MS20819-8D
	2	7 11/16	1 1/4	164	79	
	3	11 3/4	1 1/4	254	15	
		13 15/16	I	I	100 psi	
205-061-670-1	1	1 3/4	1 1/4	0	36	Y - AN818-8D MS20819-8D X - AN818-8D MS20819-8D
	2	3 1/2	1 1/4	175	38	
	3	9 1/2	1 1/4	265	19	
	4	13 11/16	1 1/4	175	26	
	5	16 1/4	1 1/4	352	26	
	6	24 9/16	1 1/4	10	30	
	7	27	1 1/4	155	26	
	8	3 17/16	1 1/4	340	12	
	9	32 3/4	1 1/4	160	14	
		33 15/16	I	I	100 psi	
205-061-671-1	1	2	1 1/4	0	135	Y - AN818-8D MS20819-8D X - AN818-8D MS20819-8D
	2	8 11/16	1 1/4	185	88	
	3	13 1/2	1 1/4	275	35	
	4	15 3/8	1 1/4	25	48	
		29 15/16	I	I	100 psi	

Table D-4. (Sheet 9 of 20)

PART NUMBER	BEND NO.	DIMENSION "A" FROM "Y" END	BEND RADIUS	DIAL SETTING	BEND ANGLE	END FITTING AND NOTES
		DIMENSION "B"	TYPE END "Y"	TYPE END "X"	PRESSURE TEST	
205-061-674-1	1	3%	1½	0	90	Y - AN818-10 MS20819-10 X - AN818-10 MS20819-10
		9%	I	I	60 psi	
205-061-675-1	1	2	1	0	27	Y - AN818-6 MS20819-6 X - AN818-6 MS20819-6
	2	8	1	79	22	
		9 11/16	I	I	60 psi	
205-061-685-1	1	1 1/16	9/16	0	114	Y - AN818-4D MS20819-4D X - AN818-4D MS20819-4D
	2	9 1/16	9/16	117	34	
	3	16 15/16	9/16	156	56	
	4	19%	9/16	343	56	
		21%	III	III	N/A	
205-062-614-1	1	1	1¼	0	3	Y - AN818-8D MS20819-8D X - AN818-8D MS20819-8D
		23%	I	I	35 psi	
205-062-662-1	1	5 9/16	15/16	0	95	Y - AN818-6D MS20819-6D X - AN818-6D MS20819-6D
		7%	I	I	35 psi	
205-062-663-1	1	24%	15/16	0	14	Y - AN818-6D MS20819-6D X - AN818-6D MS20819-6D
	2	22 1/16	15/16	180	99	
	3	12%	15/16	159	56	
	4	8%	15/16	339	59	
	5	4 11/16	15/16	0	20	
	6	1%	15/16	170	30	
		26 5/16	I	I	35 psi	
205-062-680-1	1	18	1¼	0	32	Y - AN 818-8D MS20819-8D X - AN818-8D MS20819-8D
	2	14 15/16	1¼	296	18	
	3	4%	1¼	259	8	
	4	2%	1¼	79	7	
		19%	I	I	35 psi	
205-062-681-1	1	21%	1¼	0	96	Y - AN818-8D MS20818-8D X - AN818-8D MS20819-8D
	2	17 3/16	1¼	90	9	
	3	5 13/16	1¼	90	6	
	4	2 11/16	1¼	270	6	
		22 9/16	I	I	35 psi	
205-070-365-1	1	27%	9/16	0	39.5	Y - AN818-4D MS20819-4D X - AN819-4D MS20819-4D
	2	25 13/16	9/16	188.5	39	
	3	17%	9/16	105	93.5	
	4	5 5/16	9/16	281	90	
	5	1%	9/16	190	20	
		30 13/16	I	I		
205-070-366-1	1	8%	9/16	0	41	Y - AN818-4D MS20819-4D X - AN818-4D MS20819-4D
	2	6 13/16	9/16	172	38	
	3	2 13/16	9/16	21.5	85	
	4	1%	9/16	108.5	20	
		10 5/16	I	I		

Table D-4. (Sheet 10 of 20)

PART NUMBER	BEND NO	DIMENSION "A" FROM "Y" END	BEND RADIUS	DIAL SETTING	BEND ANGLE	END FITTING AND NOTES
		DIMENSION "B"	TYPE END "Y"	TYPE END "X"	PRESSURE TEST	
	4	17 1/2	9/16	0	38	MS20819-4D
		20 3/4	III	III	150 psi	
205-070-487-1	1	3 1/2	9/16	0	20	Y - AN818-4D MS20819-4D X - AN818-4D MS20819-4D
	2	7 3/4	9/16	105	63	
	3	9 1/4	9/16	260	62	
	4	11 5/16	9/16	258	85	
	5	14	9/16	74	81	
	6	17 1/4	9/16	347	14	
	7	19 3/16	9/16	167	15	
	8	26 15/16	9/16	62	13	
	9	28 1/2	9/16	242	13	
		33 11/16	III	III	35 psi	
205-070-488-1	1	1 1/4	9/16	0	20	Y - AN818-4D MS20819-4D X - AN818-4D MS20819-4D
	2	2 9/16	9/16	180	25	
		9 1/4	III	III	150 psi	
205-070-490-1	1	2 1/4	9/16	0	9	Y - AN818-4D MS20819-4D X - AN818-4D MS20819-4D
	2	18 3/4	9/16	180	7	
		31 1/4	III	III	150 psi	
205-070-491-1	1	1 5/16	9/16	0	115	Y - AN818-4D MS20819-4D X - AN818-4D MS20819-4D
	2	4 7/16	9/16	90	56	
	3	10 3/4	9/16	252	40	
	4	32 1/16	9/16	85	35	
	5	33 1/2	9/16	250	35	
		36 7/16	III	III	N/A	
205-072-208-1	1	42 11/16	9/16	0	39	Y - AN818-4D MS20819-4D X - AN818-4D MS20819-4D
	2	41	9/16	169	39	
	3	33	9/16	90	90	
	4	20 3/4	9/16	180	90	
	5	12 3/16	9/16	90	37	
	6	9 15/16	9/16	176	35	
	7	8 11/16	9/16	275	90	
	8	4 3/16	9/16	144	48	
	9	2 1/4	9/16	182	47	
		44 3/16	I	I		
205-072-278-1	1	1 1/4	9/16	0	150	Y - AN818-4D MS20819-4D X - AN818-4D MS20819-4D
	2	6 3/4	9/16	70	21	
	3	13 3/4	9/16	167	42	
	4	21	9/16	254	23	
	5	22 1/16	9/16	76	23	
	6	23 9/16	9/16	355	51	
	7	25 3/4	9/16	172	52	
	8	28 7/16	9/16	180	24	
		29 1/2	III	III	150 psi	
205-072-304-1	1	9 7/16	9/16	0	163	Y - AN818-4D MS20819-4D X - AN818-4D MS20819-4D
	2	6 9/16	9/16	0	12	
		10 1/2	I	I		

Table D-4. (Sheet 11 of 20)

PART NUMBER	BEND NO.	DIMENSION "A" FROM "Y" END	BEND RADIUS	DIAL SETTING	BEND ANGLE	END FITTING AND NOTES
		DIMENSION "B"	TYPE END "Y"	TYPE END "X"	PRESSURE TEST	
205-072-305-1			9/16	0	43	Y - AN818-4D MS20819-4D X - AN818-4D MS20819-4D
	1	11 7/8	9/16	0	93	
	2	8 3/16	9/16	0	90	
		12.9	I	I		
205-072-410-1	1	2 5/8	3	0	116	Y - AN818-16D MS20819-16D X - AN818-16D MS20819-16D
	2	16 3/4	3	180	25	
		25 3/8	I	I	150 psi	
205-072-424-1	1	1 7/8	3	0	13	Y - AN818-16D MS20819-16D X - AN818-16D MS20819-16D
	2	11 9/16	3	97	23	
	3	17 1/8	3	235	19	
	4	23 3/8	3	212	97	
	5	31 1/2	3	116	71	
	6	46 3/4	3	125	73	
	7	53 1/4	3	245	106	
	8	61 1/2	3	155	5	
		63 1/4	I	I	150 psi	
205-075-134-1	1	2 3/4	3/4	0	120	Y - N/A X - Scarf Dial Setting 90
		5	V	IV	N/A	
205-076-033-1	1	2 3/16	9/16	0	28	Y - MS21921-4D MS21922-4 X - MS21921-4D MS21922-4
	2	5 9/16	9/16	190	47	
		13 5/16	IV	IV	1500 psi	
205-076-131-1	1	1 1/4	1	0	117	Y - MS21921-6D MS21922-6 X - MS21921-6D MS21922-6
	2	11 7/16	1	194	26	
	3	18 13/16	1	267	103	
	4	22 13/16	1	90	14	
		29 9/16	IV	IV	1500 psi	
205-076-136-1	1	3 1/8	9/16	0	86	Y - MS21921-4D MS21922-4 Y - MS21921-4D MS21922-4
	2	7	9/16	96	43	
	3	14	9/16	186	83	
	4	20 3/4	9/16	226	12	
	5	25 1/4	9/16	321	85	
		27 7/8	IV	IV	N/A	
205-076-138-1	1	1 3/8	1 1/4	0	86	Y - MS21921-8D MS21922-8 Y - MS21921-8D MS21922-8
	2	5 1/8	1 1/4	180	86	
		13 15/16	IV	IV	1500 psi	
205-076-140-1	1	1	15/16	0	96	Y - MS21921-6D MS21922-6 Y - MS21921-6D MS21922-6
	2	4 9/16	15/16	183	94	
	3	17 5/8	15/16	290	87	
	4	21	15/16	20	13	
	5	24 3/4	15/16	290	21	
	6	27 1/2	15/16	200	90	
		30 1/2	IV	IV	1500 psi	
205-076-141-1	1	3 13/16	1	0	33	Y - MS21921-6 MS21922-6
	2	6 3/16	1	180	33	

Table D-4. (Sheet 12 of 20)  
[ALL DATA ON SHEET 13 OF 20 (PAGE D-86) HAS BEEN DELETED]

PART NUMBER	BEND NO.	DIMENSION "A" FROM "Y" END	BEND RADIUS	DIAL SETTING	BEND ANGLE	END FITTING AND NOTES
		DIMENSION "B"	TYPE END "Y"	TYPE END "X"	PRESSURE TEST	
	3	18	1	180	17	X - MS21921-6 MS21922-6
	4	19 $\frac{3}{4}$	1	0	17	
		23 $\frac{3}{4}$	IV	IV	3000 psi	
205-076-156-1	1	1	9/16	0	63	Y - MS21921-4D MS21922-4
	2	8	9/16	172	67	
	3	13 $\frac{1}{4}$	9/16	352	13	X - MS21921-4D MS21922-4
	4	21 15/16	9/16	172	19	
		30 7/16	IV	IV	N/A	
205-076-157-1	1	1 $\frac{1}{4}$	1	0	180	Y - MS21921-6D MS21922-6
	2	7 $\frac{1}{4}$	1	340	27	
	3	11 $\frac{3}{4}$	1	240	92	X - MS21921-6D MS21922-6
		14 3/16	IV	IV	1500 psi	
205-076-158-1	1	20 $\frac{1}{4}$	.94	0	174	Y - MS21921-6D MS21922-6
	2	13 $\frac{3}{4}$	.94	238	90	
	3	10.00	.94	202	64	X - MS21921-6D MS21922-6
	4	8 $\frac{1}{4}$	.94	180	64	
	5	3 $1\frac{1}{16}$	.94	62	50	
	6	1 $1\frac{1}{16}$	.94	259	19	
		21 $\frac{1}{2}$	IV	IV	1500 psi	
205-076-159-1	1	6 15/16	1 $\frac{1}{4}$	0	41	Y - MS21921-8D MS21922-8
	2	14 $\frac{3}{4}$	1 $\frac{1}{4}$	192	36	
	3	17 $\frac{3}{4}$	1 $\frac{1}{4}$	144	33	X - MS21921-8D MS21922-8
	4	21 5/16	1 $\frac{1}{4}$	219	86	
		25 3/16	IV	IV	1500 psi	
205-076-160-1	1	6 $\frac{3}{4}$	9/16	0	37	Y - MS21921-4D MS21922-4
	2	20 $\frac{1}{4}$	9/16	265	35	
	3	23 $\frac{3}{4}$	9/16	175	77	X - MS21921-4D
		26 $\frac{3}{4}$	IV	IV	1500 psi	
205-076-161-1	1	1 7/16	9/16	0	86	Y - MS21921-4D MS21922-4
	2	6 $\frac{3}{4}$	9/16	140	91	
		10 $\frac{1}{4}$	IV	IV	1500 psi	
205-076-200-1	1	1.88	9/16	0	141	Y - MS21921D4 MS21922-4
	2	4 3/4	9/16	135	65	
		6.75	IV	IV	3000	X - MS21921D4 MS21922-4
205-076-201-1	1	1 5/16	1	0	20	Y - MS21921-6D MS21922-6
	2	2 $\frac{3}{4}$	1	270	90	
	3	8 $\frac{1}{4}$	1	200	20	X - MS21921-6D MS21922-6
	4	9 $\frac{3}{4}$	1	100	90	
		12 $\frac{3}{4}$	IV	IV	1500 psi	
205-076-202-1	1	2 $\frac{1}{4}$	15/16	0	92	Y - MS21922-6 MS21921-6D
	2	8	15/16	251	120	
		11 7/16	IV	IV	1500 psi	X - MS21922-6 MS21921-6D

Table D-4. (Sheet 14 of 20)



PART NUMBER	BEND NO.	DIMENSION "A" FROM "Y" END	BEND RADIUS	DIAL SETTING	BEND ANGLE	END FITTING AND NOTES
		DIMENSION "B"	TYPE END "Y"	TYPE END "X"	PRESSURE TEST	
205-076-203-1	1	2%	1	0	10	Y - MS21921-6D MS21922-6
	2	8	1	180	10	
			9%	IV	IV	1500 psi
205-076-204-1	1	2 13/16	1	0	75	Y - MS21921-6D MS21922-6
	2	8 9/16	1	180	75	
	3	16	1	180	90	X - MS21921-6D MS21922-6
	4	18 13/16	1	270	23	
		21%	IV	IV	1500 psi	
205-076-205-1	1	12 1/4	9/16	0	36	Y - MS21921D4 MS21922-4
	2	9 7/8	9/16	180	43	
	3	6 1/16	9/16	2	29	X - MS21921D4 MS21922-4
	4	2 5/16	9/16	182	23	
		13 5/8	IV	IV	3000	
205-076-206-1	1	2%	9/16	0	89	Y - MS21921-4D MS21922-4
	2	5	9/16	150	89	
	3	11%	9/16	140	89	X - MS21921-4D MS21922-4
	4	14 1/16	9/16	300	89	
		16 3/16	IV	IV	1500 psi	
205-076-207-1	1	2 7/16	9/16	0	50	Y - MS21921-4 MS21922-4
	2	4 9/16	9/16	180	50	
	3	11 1/2	9/16	95	12	X - MS21921-4 MS21922-4
		13%	IV	IV	3000 psi	
205-076-208-1	1	2 7/16	9/16	0	81	Y - MS21921D4 MS21922-4
	2	5 9/16	9/16	275	36	
	3	19	9/16	195	41	X - MS21921D4 MS21922-4
	4	31 1/4	9/16	295	89	
	5	35	9/16	75	82	
		36 1/4	IV	IV	3000	
205-076-209-1	1	1 5/16	9/16	0	45	Y - MS21921-4D MS21922-4
	2	13%	9/16	180	48	
	3	27 5/16	9/16	96	22	X - MS21921-4D MS21922-4
	4	30 5/16	9/16	4	87	
		32%	IV	IV	1500 psi	
205-076-210-1	1	1	9/16	0	41	Y - MS21921-4 MS21922-4
	2	3 7/16	9/16	180	41	
	3	9%	9/16	180	20	X - MS21921-4 MS21922-4
	4	9 15/16	9/16	0	25	
		11 13/16	IV	IV	3000 psi	
205-076-212-1	1	2 1/16	1	0	35	Y - MS21921-6 MS21922-6
	2	4%	1	180	35	
	3	17 3/16	1	175	48	X - MS21921-6 MS21922-6
	4	20 13/16	1	355	44	
		23 13/16	IV	IV	3000 psi	

Table D-4. (Sheet 15 of 20)

PART NUMBER	BEND NO.	DIMENSION "A" FROM "Y" END	BEND RADIUS	DIAL SETTING	BEND ANGLE	END FITTING AND NOTES
		DIMENSION "B"	TYPE END "Y"	TYPE END "X"	PRESSURE TEST	
205-076-213-1	1	2 1/2	1	0	23	Y - MS21921-6D MS21922-6 X - MS21921-6D MS21922-6
	2	4	1	180	23	
	3	11 1/2	1	100	67	
	4	14 3/4	1	280	67	
	5	21 3/16	1	180	10	
	6	29 1/2	1	353	8	
		31 1/4	IV	IV	1500 psi	
205-076-214-1	1	1 3/4	15/16	0	91	Y - MS21921-6D MS21922-6 X - MS21921-6D MS21922-6
	2	4 1/4	15/16	150	89	
	3	10 13/16	15/16	150	93	
	4	13 5/16	15/16	310	90	
			15 13/16	IV	IV	
205-076-215-1	1	1 3/4	15/16	0	90	Y - MS21921D6 MS21922-6 X - MS21921D6 MS21922-6
	2	5 7/8	15/16	270	21	
	3	10 3/4	15/16	20	72	
	4	23	15/16	315	25	
			26 1/2	IV	IV	
205-076-216-1	1	2	1	0	29	Y - MS21921-6D MS21922-6 X - MS21921-6D MS21922-6
	2	11 3/4	1	320	45	
	3	13 3/4	1	245	95	
			17 3/4	IV	IV	
205-076-217-1	1	2 7/16	1	0	8	Y - MS21921-6D MS21922-6 X - MS21921-6D MS21922-6
	2	7 13/16	1	200	95	
	3	13 3/4	1	208	90	
			22	IV	IV	
205-076-221-1	1	1 1/8	9/16	0	90	Y - MS21921D4 MS21922-4 X - None
	2	4 1/2	9/16	90	37	
	3	10 1/8	9/16	15	84	
	4	16 1/2	9/16	85	65	
	5	28 3/8	9/16	90	12	
	6	30 3/4	9/16	180	12	
	7	40 3/4	9/16	85	55	
	8	44 3/8	9/16	270	14	
	9	45 1/2	9/16	270	64	
		46 7/8	IV	V	None	
205-076-223-1	1	2 3/4	9/16	0	90	Y - MS21921-4D MS21922-4 X - MS21921-4D MS21922-1
	2	7	9/16	0	90	
			9	IV	IV	
205-076-227-1	1	1 3/4	15/16	0	90	Y - MS21921D6 MS21922-6 Y - MS21921D6 MS21922-6
	2	6 1/4	15/16	265	135	
	3	9 1/2	15/16	180	35	
	4	14 1/2	15/16	270	10	
	5	17 1/2	15/16	180	85	
	6	20 7/8	15/16	265	85	
	7	27 1/4	15/16	225	85	
			28 1/4	IV	IV	

Table D-4. (Sheet 16 of 20)

PART NUMBER	BEND No.	DIMENSION "A" FROM "Y" END	BEND RADIUS	DIAL SETTING	BEND ANGLE	END FITTING AND NOTES
		DIMENSION "B"	TYPE END "Y"	TYPE END "X"	PRESSURE TEST	
205-076-231-1	1	17 1/2	1 1/2	0	33	Y - MS21921D8 MS21922-8 X - MS21921D8 MS21922-8
	2	11 1/2	1 1/2	90	90	
	3	6	1 1/2	145	90	
	4	3	1 1/2	45	33	
		21 1/2	IV	IV	3000	
205-076-232-1	1	13 3/4	15/16	0	128	Y - MS21921D6 MS21922-6 X - MS21921D6 MS21922-6
	2	8 1/2	15/16	280	72	
	3	5 5/8	15/16	38	47	
	4	3 1/4	15/16	270	89	
			IV	IV	3000	
205-076-233-1	1	2 3/16	9/16	0	43	Y - MS21921-4D MS21922-4 X - Scarf Dial Setting 151
	2	5 11/16	9/16	180	43	
	3	9 1/4	9/16	183	37	
	4	15 1/4	9/16	3	36	
	5	24 3/4	9/16	241	12	
	6	27 1/4	9/16	61	13	
	7	36 13/16	9/16	61	61	
	8	38 1/2	9/16	241	63	
		40 3/4	IV	V	N/A	
205-076-235-1	1	29 3/4	1.0	0	26	Y - MS21919-6D MS21922-6 X - MS21919-6D MS21922-6
	2	28 3/4	1.0	179	24	
	3	20 7/8	1.0	225	59	
	4	19	1.0	321	37	
	5	17 3/4	1.0	76	59	
	6	11 3/4	1.0	151	31	
	7	9 7/16	1.0	332	35	
	8	3 15/16	1.0	359°30'	23°30'	
	9	2 3/16	1.0	177°30'	22	
		34.0	I		3000 psi	
205-076-236-1	1	1	15/16	0	15	Y - MS21921-6D MS21922-6 X - MS21921-6D MS21922-6
	2	4 1/4	15/16	270	90	
	3	7 1/4	15/16	355	25	
		9 1/4	IV	IV	1500 psi	
205-076-237-1	1	3 1/16	1	0	37	Y - MS21921-6D MS21922-6 X - MS21921-6D MS21922-6
	2	7 1/2	1	12	54	
		9 3/4	IV	IV	1500 psi	
205-076-238-1	1	5 3/16	1	0	90	Y - MS21921-6D MS21922-6 X - MS21921-6D MS21922-6
	2	10 3/4	1	7	90	
	3	17 3/4	1	240	8	
		19 3/4	IV	IV	1500 psi	
205-076-240-1	1	1 1/4	1	0	5	Y - MS21921-6D MS21922-6 X - MS21921-6D MS21922-6
	2	9 3/4	1	270	88	
	3	13 7/16	1	358	52	
	4	17	1	178	52	
	5	19 1/2	1	146	90	
	6	22 3/4	1	236	35	
	7	25 11/16	1	322	86	
	8	33 3/4	1	218	30	
	9	34 3/4	1	38	30	
	37 3/4	IV	IV	1500 psi		

Table D-4. (Sheet 17 of 20)

PART NUMBER	BEND NO.	DIMENSION "A" FROM "Y" END	BEND RADIUS	DIAL SETTING	BEND ANGLE	END FITTING AND NOTES
		DIMENSION "H"	TYPE END "Y"	TYPE END "X"	PRESSURE TEST	
205-076-241-1	1	5 3/4	1	0	35	Y - MS21921-6D MS21922-6 X - MS21921-6D MS21922-6
	2	7 3/8	1	180	35	
	3	15 3/16	1	100	85	
	4	25 1/2	1	10	10	
		29	IV	IV	1500 psi	
205-076-242-1	1	1	1	0	55	Y - MS21921-6D MS21922-6 X - MS21921-6D MS21922-6
	2	3 3/4	1	180	55	
	3	5 1/4	1	90	40	
	4	13 15/16	1	180	92	
	5	20 1/2	1	310	40	
	6	27 1/2	1	53	95	
		30 1/2	IV	IV	1500 psi	
205-076-244-1	1	2 1/4	1	0	57	Y - MS21921-6D MS21922-6 X - MS21921-6D MS21922-6
	2	6 9/16	1	180	60	
	3	17 11/16	1	180	53	
	4	20 3/8	1	0	53	
		22 7/8	IV	IV	1500 psi	
205-076-245-1	1	2	1	0	60	Y - MS21921-6D MS21922-6 X - MS21921-6D MS21922-6
	2	5 3/4	1	180	60	
	3	17 3/8	1	180	50	
	4	20 1/8	1	0	55	
		22 11/16	IV	IV	1500 psi	
205-076-246-1	1	1 1/16	1	0	83	Y - MS21921-6D MS21922-6 X - MS21921-6D MS21922-6
	2	3 7/16	1	180	80	
	3	15 3/8	1	130	74	
	4	18 3/8	1	310	68	
		20 15/16	IV	IV	1500 psi	
205-076-247-1	1	1 7/8	1	0	58	Y - MS21921-6D MS21922-6 X - MS21921-6D MS21922-6
	2	3 3/8	1	180	48	
	3	13 3/8	1	110	88	
	4	16 3/8	1	290	88	
		20 9/16	IV	IV	1500 psi	
205-076-248-1	1	2 1/4	1	0	30	Y - MS21921-6D MS21922-6 X - MS21921-6D
	2	12 1/2	1	190	30	
	3	21 3/8	1	165	60	
	4	27 1/8	1	345	60	
		30 3/8	IV	IV	1500 psi	
205-076-249-1	1	1 1/2	1	0	60	Y - MS21921-6D MS21922-6 X - MS21921-6D MS21922-6
	2	8	1	180	60	
	3	17 1/2	1	180	30	
	4	28 3/8	1	0	30	
		30 3/8	IV	IV	1500 psi	
205-076-250-1	1	1 15/16	1	0	69	Y - MS21921-6D MS21922-6 X - MS21921-6D MS21922-6
	2	4 1/2	1	105	45	
	3	9 3/8	1	141	70	
	4	12 3/16	1	330	70	
	5	20 1/2	1	321	34	
	6	22 9/16	1	140	34	
		24 3/8	IV	IV	1500 psi	

Table D-4. (Sheet 18 of 20)

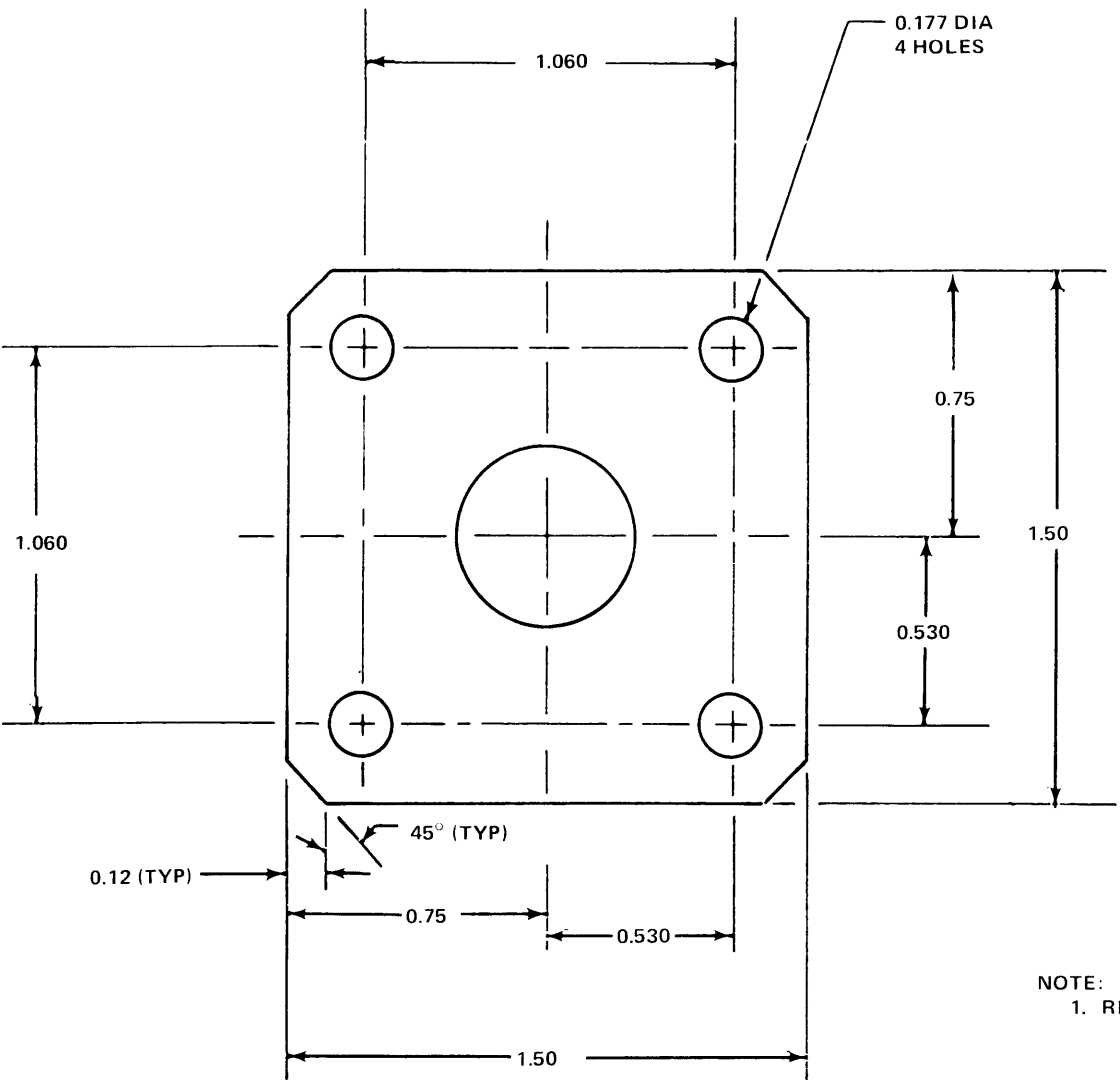
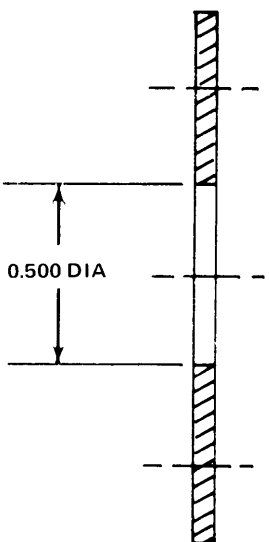
PART NUMBER	BEND NO.	DIMENSION "A" FROM "Y" END DIMENSION "B"	BEND RADIUS TYPE END "Y"	DIAL SETTING TYPE END "X"	BEND ANGLE PRESSURE TEST	END FITTING AND NOTES
205-076-251-1	1	1%	1	0	27	Y - MS21921-6D MS21922-6 X - MS21921-6D MS21922-6
	2	2%	1	183	30	
	3	10%	1	156	74	
	4	14%	1	340	74	
		18%	IV	IV	1500 psi	
205-076-252-1	1	3%	1	0	75	Y - MS21921-6D MS21922-6 X - MS21921-6D MS21922-6
	2	7 3/16	1	173	79	
	3	15	1	193	27	
	4	16 9/16	1	14	27	
		18 1/2	IV	IV	1500 psi	
205-076-253-1	1	2	1	0	62	Y - MS21921-6D MS21922-6 X - MS21921-6D MS21922-6
	2	4%	1	250	42	
	3	9%	1	222	67	
	4	12	1	32	68	
	5	19%	1	44	35	
	6	21%	1	215	32	
		24 3/16	IV	IV	1500 psi	
205-076-254-1	1	3 5/16	1/4	0	65	Y - MS21921-4D MS21922-4 X - MS21921-4D MS21922-4
		6	IV	IV	1500 psi	
205-076-255-1	1	1%	9/16	0	55	Y - MS21921-4D MS21922-4 X - MS21921-4D MS21922-4
		5%	IV	IV	1500 psi	
205-076-257-1	1	1%	1	0	128	Y - MS21921-6D MS21922-6 X - MS21921-6D MS21922-6
	2	6	1	240	65	
	3	9%	1	300	8	
		14%	IV	IV	1500 psi	
205-076-258-1	1	1%	1 1/4	0	90	Y - MS21921-8 MS21922-8 X - MS21921-8 MS21922-8
	2	13 1/2	1 1/4	255	23	
		19 15/16	IV	IV	3000 psi	
205-076-259-1	1	1 1/2	1 1/4	0	93	Y - MS21921-8D MS21922-8 X - MS21921-8D MS21922-8
	2	14 5/16	1 1/4	272	19	
	3	22%	1 1/4	92	10	
	4	26	1 1/4	206	58	
	5	31	1 1/4	116	10	
		33 1/2	IV	IV	1500 psi	
99C29	1	2 7/16	9/16	0	60	Y - AN818-4D MS20819-4D X - AN818-4D MS20819-4D
	2	4%	9/16	188	63	
		8%	III	III	150 psi	
99C30	1	15/16	1	0	90	Y - AN818-4D MS20819-4D X - AN818-4D MS20819-4D
	2	3 1/2	1	270	26	
	3	6 13/16	1	225	16	
	4	13 1/16	1	45	16	
		15	III	III	150 psi	

Table D-4. (Sheet 19 of 20)

PART NUMBER	BEND NO.	DIMENSION "A" FROM "Y" END	BEND RADIUS	DIAL SETTING	BEND ANGLE	END FITTING AND NOTES
		DIMENSION "B"	TYPE END "Y"	TYPE END "X"	PRESSURE TEST	
205-040-142-1	1	4.00	1.50		23	X - AN818-10D MS20819-10D Y - AN818-10D MS20819-10D
	2	7.19	1.50	135	20	
205-040-143-1	1	2.06	1.50		90	X - AN818-10D MS20819-10D Y - AN818-10D MS20819-10D
	2	8.88	1.50	180	90	
205-040-144-1	1	54.25	1.50		32	X - AN818-10D MS20819-10D Y - AN818-10D MS20819-10D Pressure Test 120 PSI
	2	49.81	1.50	174	27	
	3	44.93	1.50	134	27	
	4	29.43	1.50	317	21	
	5	16.37	1.50	4	17	
	6	13.12	1.50	190	17	
205-040-145-1	No Bends					X - AN818-10D MS20819-10D Y - AN818-10D MS20819-10D
205-040-146-1	1	1.00	1.50		49	X - AN818-10D MS20819-10D Y - AN818-10D MS20819-10D
	2	6.25	1.50	185	50	
	3	11.25	1.50	252	25	
	4	26.50	1.50	67	25	
	5	34.06	1.50	22	11	
	6	36.12	1.50	202	10	
205-040-147-1	1	3.44	1.50		90	X - AN818-10D MS20819-10D Y - AN818-10D MS20819-10D
	2	10.25	1.50	180	90	
205-040-148-1	1	3.38	1.50		20	X - AN818-10D MS20819-10D Y - AN818-10D MS20819-10D
	2	6.69	1.50	135	19	
205-040-150-1	1	2.12	.94		172	X - AN818-10D MS20819-10D Y - AN818-10D MS20819-10D
	2	5.75	.94	180	86	
205-040-151-1	No Bends					X - AN818-10D MS20819-10D
205-040-203-1	1	11.69	1.75	49		X - AN818-12D MS20819-12D Y - AN818-12D MS20819-12D
	2	3.38	1.75	43		
UH-1-L0001-1	1	3 7/8	1 3/4	0	83	X - AN819-12D MS20819-12 Y - AN819-12D MS20819-12
	2	11 3/4	1 3/4	90	56	
	3	21 3/8	1 3/4	90	39	
	4	29	1 3/4	165	73	
	5	38 3/4	1	1	0	
UH-1-L0001-2	1	15 1/8	1 3/4	0	59	X - None End X: Scarf 45°, 60° from 0° Y - AN818-12D MS20819-12
	2	24 5/8	1 3/4	180	76	
	3	30 1/2	1	V	0	

Table D4.(Sheet 19 of 20)

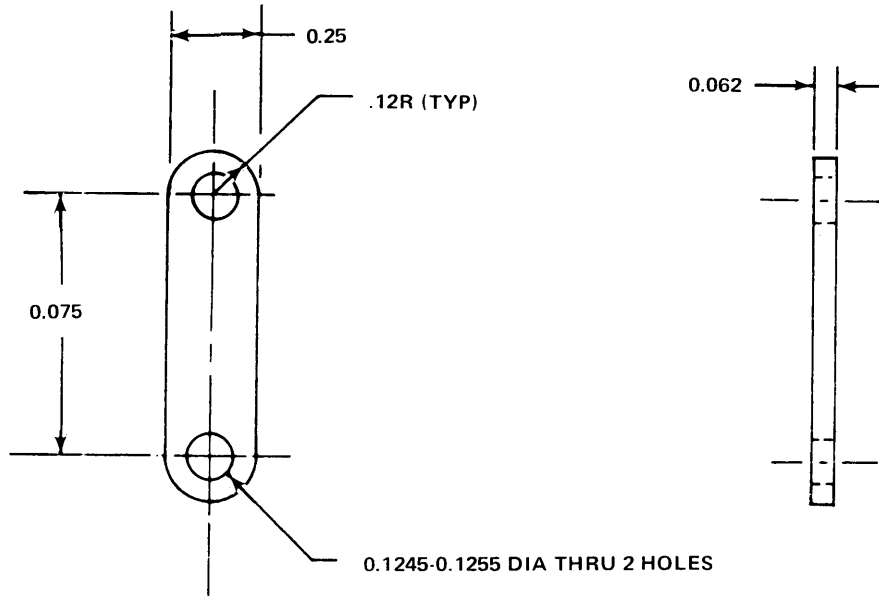




NOTE:  
1. REMOVE ALL BURRS

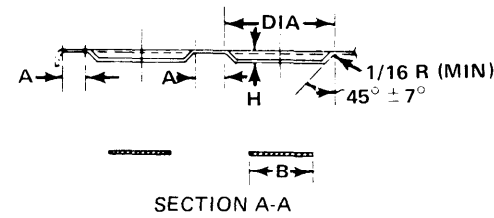
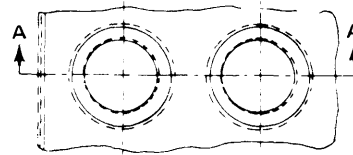
**Figure D-43.** Part Number 28D00 PLATE, RETAINER  
Fabricate from: NSN 9535-00-640-2311  
Material: 2024 AL AL Y Sheet, Federal Specification QQ-A-250/5, 0.063 Inch Thick





NOTE:  
1. PASSIVATED FINISH

**Figure D-44.** Part Number 49C16 LINK, VALVE ASSEMBLY  
Fabricate from: NSN 9515-00-234-7953  
Material: Metal Sheet - Steel, Corrosion Resistant Cold Roll,  
Federal Sepcification MIL-S-5059A, 0.063 Inch Thick

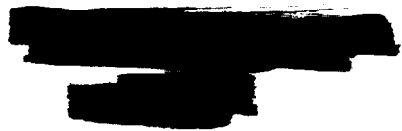
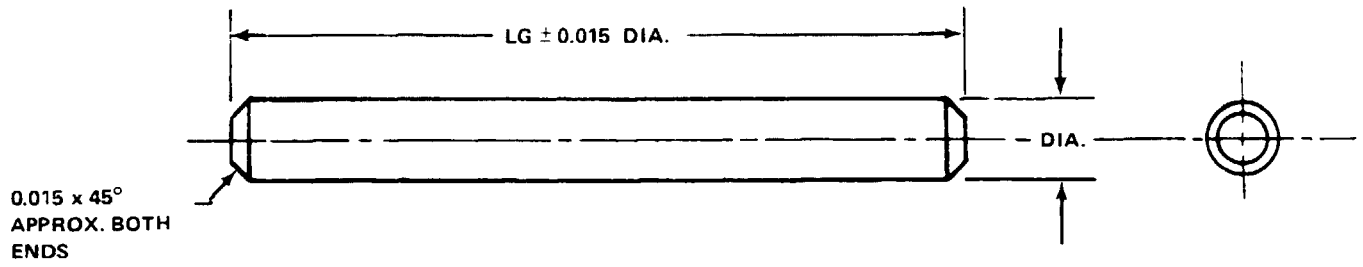


DASH NO.	DIA. OF HOLE D	BLANK DIA. B	AREA OF BLANK SQ. IN.	H ±1/32	A MIN
4	1	.6895	.37	1/8	5/16
5	1-1/4	.9375	.69	1/8	5/16
6	1-1/2	1.000	.78	3/16	11/32
7	1-3/4	1.250	1.23	3/16	11/32
8	2	1.500	1.77	3/16	11/32
9	2-1/4	1.750	2.41	3/16	11/32
10	2-1/2	2.000	3.14	3/16	11/32
11	2-3/4	2.250	3.98	3/16	11/32
12	3	2.500	4.91	3/16	11/32
13	3-1/4	2.625	5.41	1/4	3/8
14	3-1/2	2.875	6.49	1/4	3/8
15	3-3/4	3.125	7.67	1/4	3/8
16	4	3.375	8.94	1/4	3/8
17	4-1/4	3.625	10.32	1/4	3/8
18	4-1/2	3.875	11.79	1/4	3/8
19	4-3/4	4.125	13.36	1/4	3/8
20	5	4.375	15.00	1/4	3/8
CONTINUE IN 1/4 INCH INCREMENTS					

NOTES:

1. THE MINIMUM HOLE SHALL BE 1" IN DIAMETER (D).  
 COVE: DASH NUMBER INDICATED DIAMETER OF HOLE (D) IN 1/4 INCH INCREMENTS  
 EXAMPLE: 50H1-8 = HOLE - CIRCULAR LIGHTENING -45° FLANGE, 2" DIAMETER

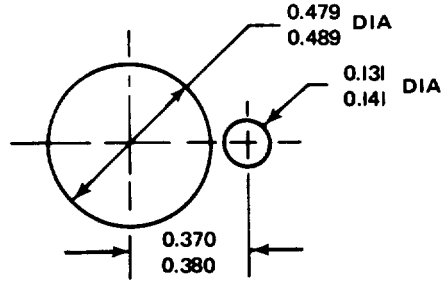
Figure D-45. Part Number 50H1 Lightning Hole Pattern



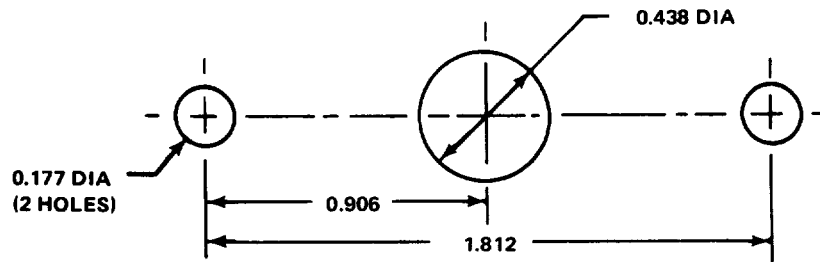
PART NUMBER	FABRICATE FROM NSN	DIA.	LENGTH
MS20253-2-225	5340-00-068-4378	0.089	2.250
MS20253-2-275	5340-00-573-0780	0.089	2.750
MS20253-2-600	5340-00-573-0780	0.089	6.000
MS20253-2-2450	5340-00-068-4378	0.089	24.50
MS20253-2-7950	9505-00-596-1662	0.089	79.500
MS20253-2-10350	9505-00-596-1662	0.089	103.500
MS20253P2-275	5340-00-043-3723	0.089	2.750
MS20253P2-387	5340-00-043-3723	0.089	3.870
MS20253P2-2372	5340-00-043-3723	0.089	23.720

PIN, Straight Headless

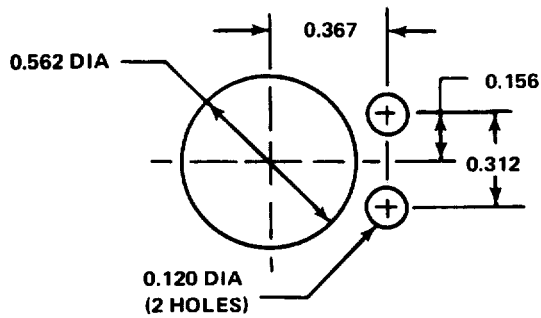
Figure D-46



59H21-1  
SUPERSEDED BY 160-005-1



59H21-2



59H21-3

DIMENSIONS IN INCHES: UNLESS OTHERWISE SPECIFIED  
TOLERANCES: THREE  
PLACE DECIMALS  $\pm 0.005$

Figure D-47. Part Number 59H21 HOLE PATTERNS

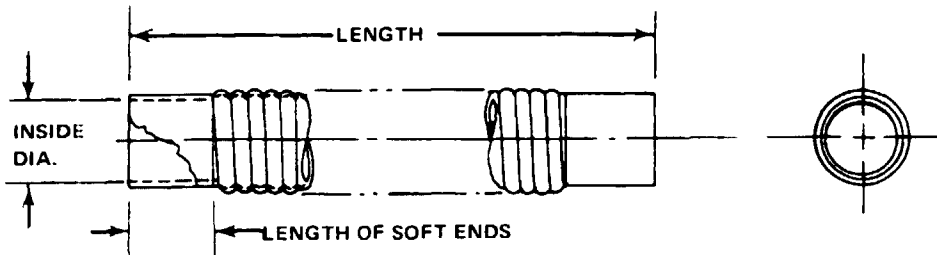


Figure D-48.

HOSE PART NUMBER	FABRICATE FROM NSN	ID.	LG.	SOFT END L.G.
70-00188F18Z3	4720-00-707-6900	2.000 IN.	9.000 IN.	1.500 IN.
70-00188F59Z3	4720-00-707-6900	2.000 IN.	29.500 IN.	1.500 IN.
70-001810F66Z2	4720-00-736-0985	2.500 IN.	2.900 IN.	1.000 IN.
70-001812F13Z3	4720-00-736-0986	3.000 IN.	6.500 IN.	1.500 IN.
70-001812F22Z2	4720-00-736-0986	3.000 IN.	11.99 IN.	1.000 IN.
70-001812F27Z2	4720-00-736-0986	3.000 IN.	13.500 IN.	1.000 IN.
70-001812F52Z3	4720-00-736-0986	3.000 IN.	26.000 IN.	1.500 IN.
70-001820F12Z3	4720-00-736-0986	5.000 IN.	6.000 IN.	1.500 IN.
70-004A10F23Z2	4720-00-736-0985	2.500 IN.	11.500 IN.	1.000 IN.
70-004A10F24Z2	4720-00-736-0985	2.500 IN.	12.00 IN.	1.000 IN.
70-004A10F25Z3	4720-00-736-0985	2.500 IN.	12.500 IN.	1.500 IN.
70-004A12F27Z2	4720-00-736-0986	3.000 IN.	13.500 IN.	1.000 IN.

HOSE, Air Duct

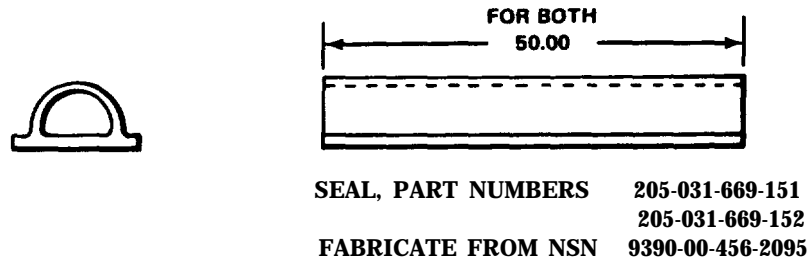


Figure D-49.

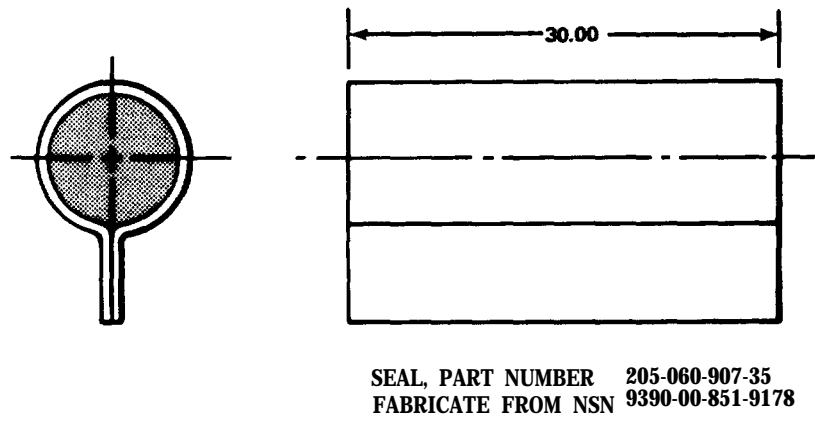


Figure D-50.

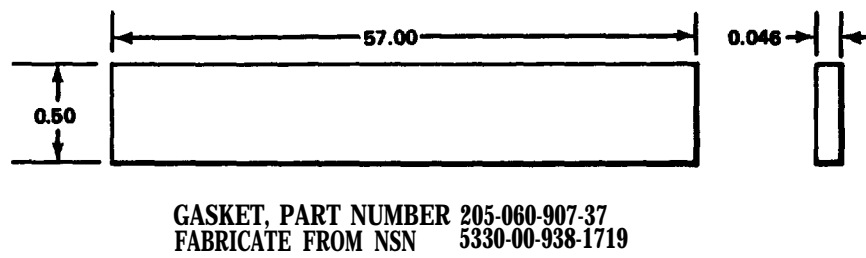
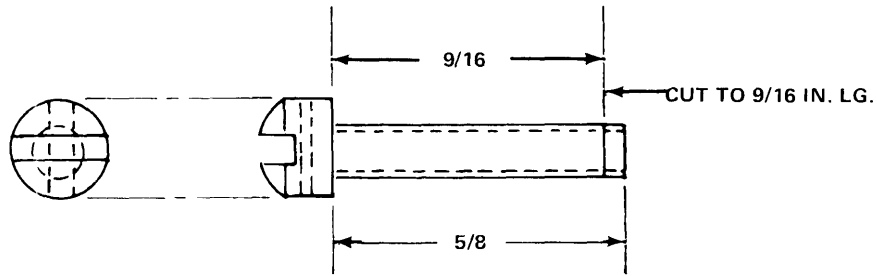
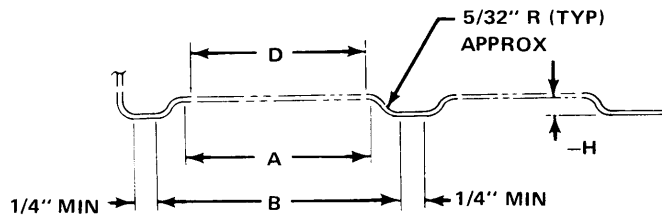


Figure D-51.



NO. 4-40 x  $\frac{9}{16}$ " DRILLED FILLISTER HEAD  
MACHINE SCREW WITH SLOTTED HEAD.

**Figure D-52.** Part Number BYRF572 SCREW, MACHINE  
Fabricate from: NSN 5305-00-579-4554



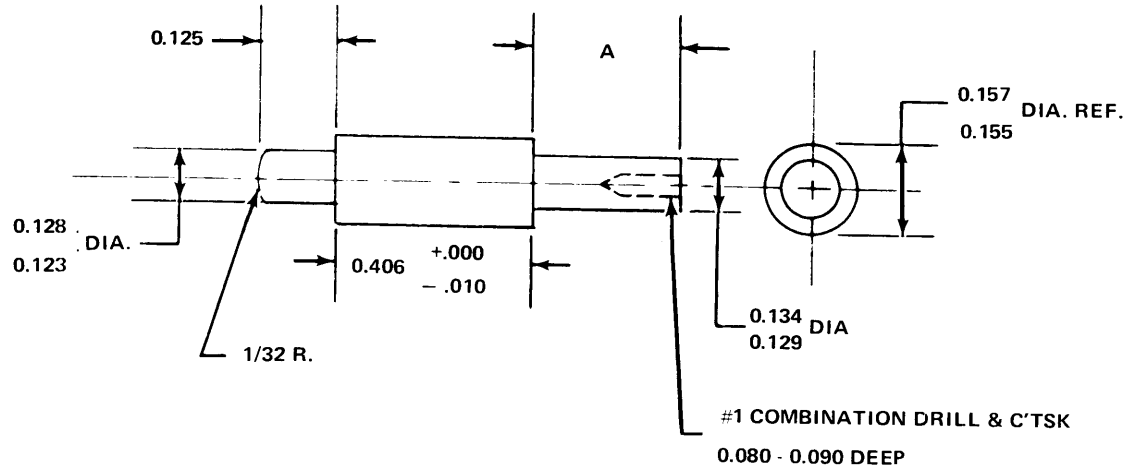
DASH NO.	D	H	A	B APPROX.	MATERIAL THICKNESS LIMITATIONS
-4	3/4	1/8	7/8	1-11/32	0.020 MAX
-5	1	1/8	1-1/8	1-19/32	0.025 MAX
-6	1-1/8	3/16	1-1/4	1-25/32	0.032 MAX
-7	1-3/8	3/16	1-1/2	2-1/32	0.040 MAX
-8	1-5/8	3/16	1-3/4	2-9/32	0.051 MAX
-9	1-7/8	3/16	2	2-17/32	
-10	2-1/8	3/16	2-1/4	2-25/32	
-11	2-3/8	3/16	2-1/2	3-1/32	
-12	2-5/8	3/16	2-3/4	3-9/32	
-13	2-3/4	1/4	2-7/8	3-7/16	
-14	3	1/4	3-1/8	3-11/16	
-15	3-1/4	1/4	3-3/8	3-15/16	
-16	3-1/2	1/4	3-5/8	4-3/16	
-17	3-3/4	1/4	3-7/8	4-7/16	
-18	4	1/4	4-1/8	4-11/16	
-19	4-1/4	1/4	4-3/8	4-15/16	
-20	4-1/2	1/4	4-5/8	5-3/16	
CONTINUE IN 1/4 INCH INCREMENTS					
-23 THRU -30					0.020 MIN 0.051 MAX

NOTE:

MAY BE USED AS AN ALTERNATE FOR BELL STANDARD 50H1 LIGHTENING HOLES DASH NUMBER FOR DASH NUMBER WITHIN MATERIAL LIMITS SHOWN. (MATERIAL SHOULD BE IN "0" INITIAL CONDITION. )

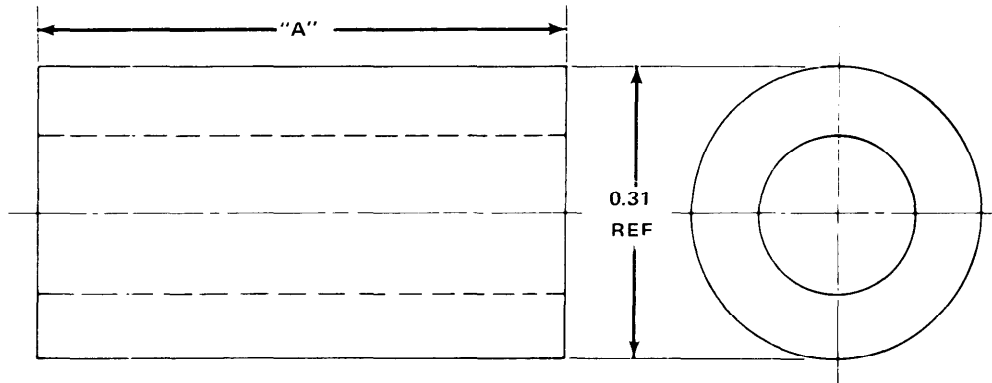
Figure D-53. Part Number 70-017 HOLE PATTERNS





PART NO.	A
-1	0.344
-2	0.218

**Figure D-54.** Part Number SP 401-1 PIN, Shoulder  
 SP 401-2  
 Fabricate from: NSN 9530-00-167-1817  
 Material: Wire Non-Electric Nickel Annealed Cold,  
 Federal Specification MIL-N-6710, Cond A, 0.250 Inch Dia.

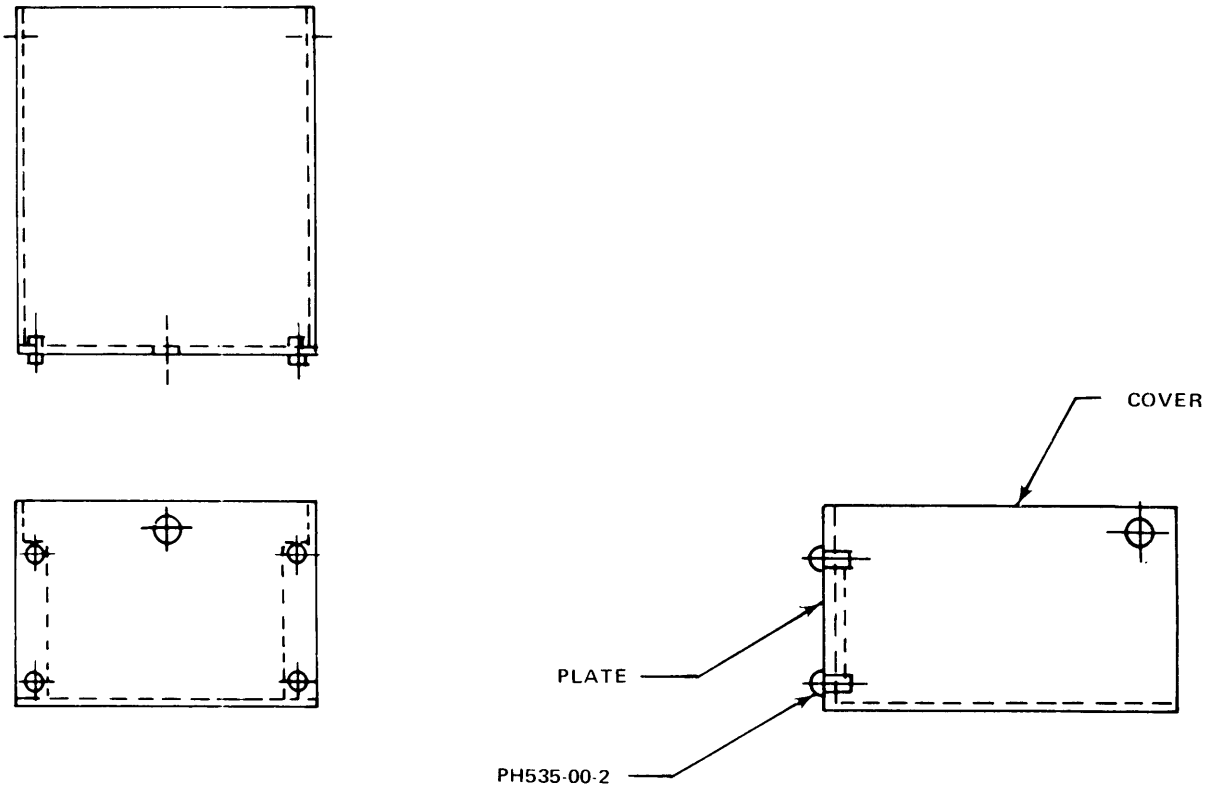


PART NUMBER	"A"	NEXT ASSY	APPLICATION QTY. REQ'D		
			USED ON	NEXT ASSY	USED ON
B79C65	0.61	A71C09	A71C09	1	1

MATERIAL: 5/16 O.D. x .058 WALL  
THICKNESS TYPE  
6061 AL. ALY. TUBING  
PER WW-T-789

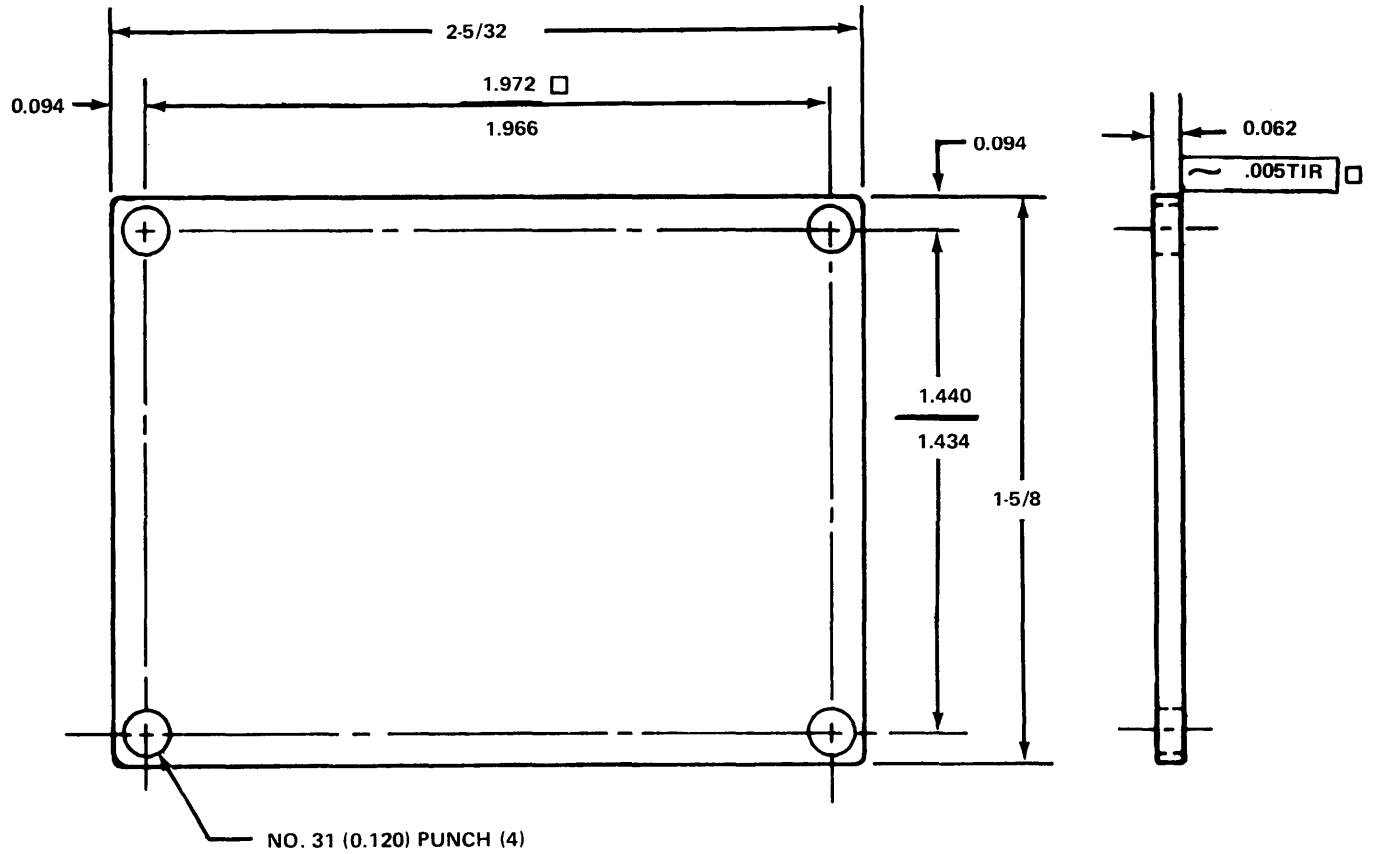
NOTE:  
1. REMOVE ALL BURRS

**Figure D-55.** Part Number B79C65 SPACER  
Fabricate from: NSN 5340-00-727-1891  
Material: Spacer, Sleeve Aluminum Alloy. 0.194 inch ID. 0.322 inch O.D. 20 inch long.



**Figure D-56.**

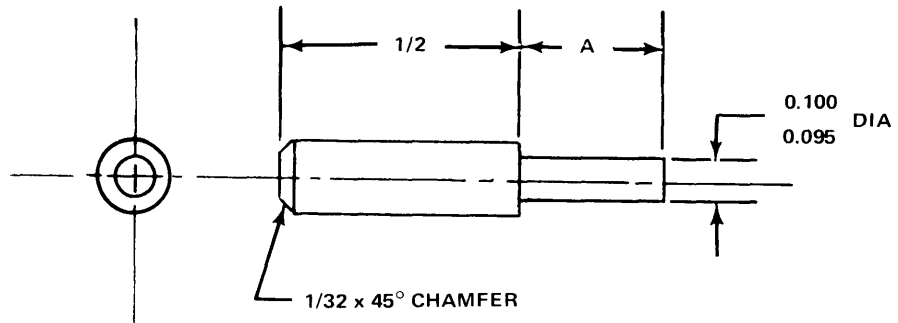
Part Number	B56C21 COVER ASSEMBLY
Fabricate from:	NSN 9535-00-167-2280 NSN 5305-00-253-5604
Material:	2024 AL ALY, Federal Specification QQ-A-250/5, 0.040 Inch Thick.



NOTES:

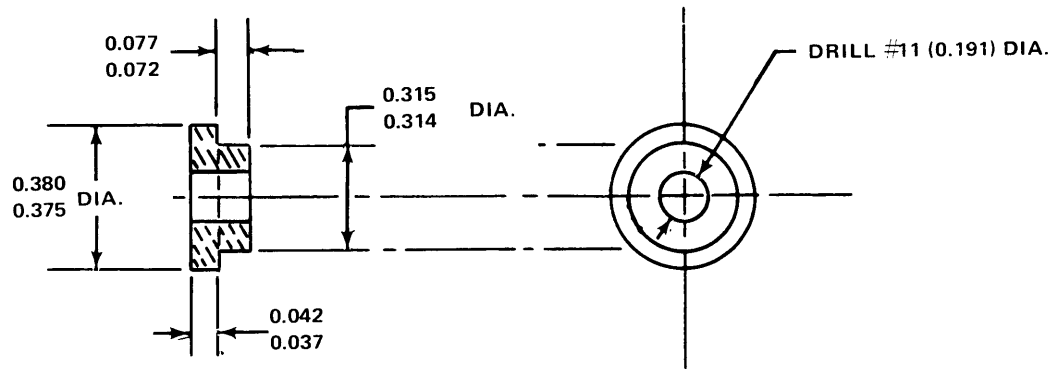
1. MUST BE FREE OF BURRS
2. ALODIZE MIL-C-5541 (1)

**Figure D-57.** Part Number NYLC3, COVER PLATE, Access  
 Fabricate from: NSN 9535-00-232-0378  
 Material: 2024 AL ALY Sheet, Federal Specification QQ-A-250/5, 0.063 Inch Thick



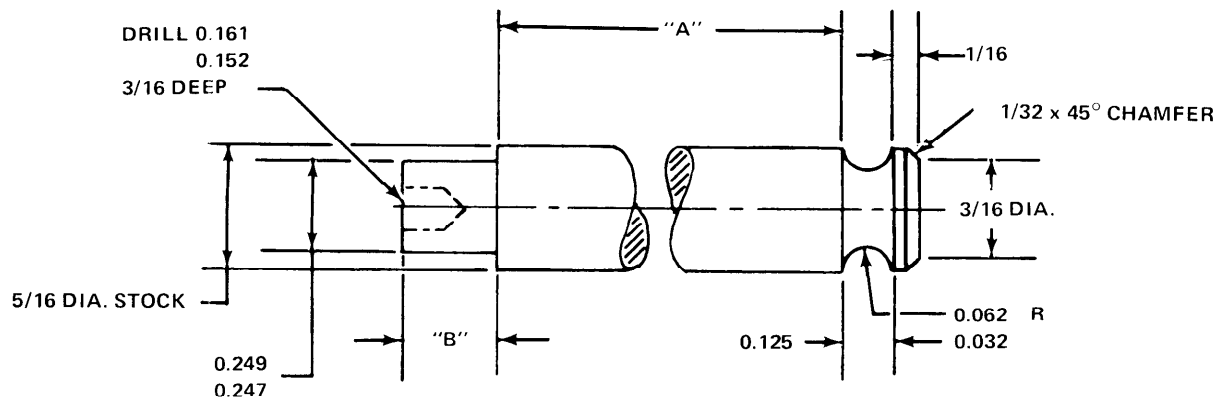
PART NO.	A
SP 469-1	5/16
SP 469-2	5/8

**Figure D-58.** Part Number SP 469-1 POST, Micro Switch  
 Fabricate from: -NSN 9530-00-167-1817  
 Material: Wire, Nonelectric Nickle Annealed, Federal Specification M16-N-6710, Cond A, 0.250 Inch Dia.



**Figure D-59.**

Part Number	SP 516 BUSHING, Solenoid
Fabricate from:	NSN 9530-00-167-1818
Material:	Metal Rod-Nickel, Cold Finish Annealed, Federal Specification MIL-N-6710, 0.375 Inch Dia.

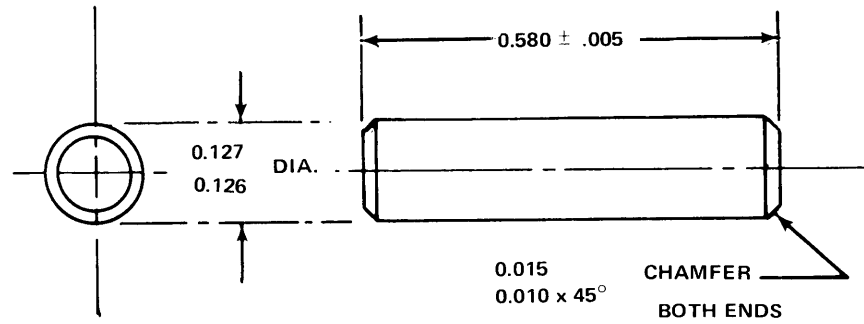


DASH. NO.	DIM "A"	DIM "B"
-2	1-1/32	0.250

NOTES:

1. BREAK ALL SHARP EDGES .005 TO 0.10
2. CAD. PLATE QQ-P-416 TYPE 1 CLASS A

**Figure D-60.** Part Number SP 1152-2 SUPPORT, Spring  
 Fabricate from: NSN 9510-00-294-9660  
 Material:

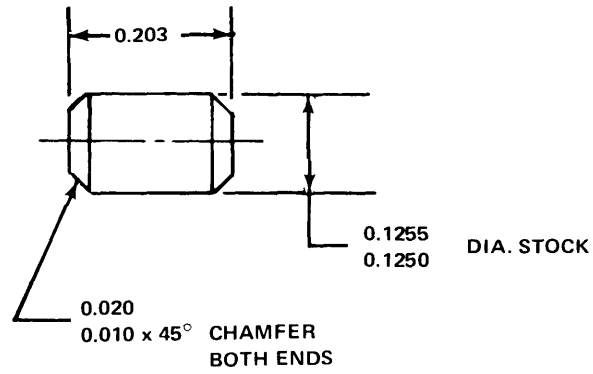


NOTES:

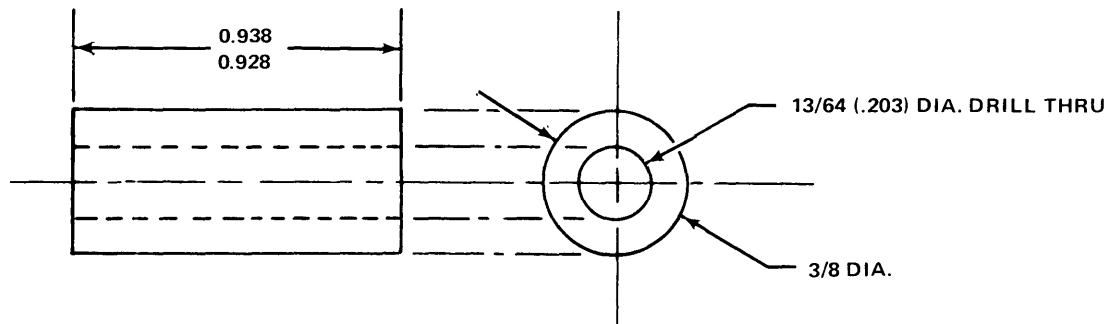
1. HEAT TREAT TO ROCKWELL C-34 TO C-38

**Figure D-61.** Part Number SP 1699-1 PIN, Solenoid Shaft  
 Fabricate from: NSN 9510-00-294-9666  
 Material: Metal Bar - Steel Cold. Federal Specification MIL-S-6758, 4130 Comp, 0.375 Inch Dia.



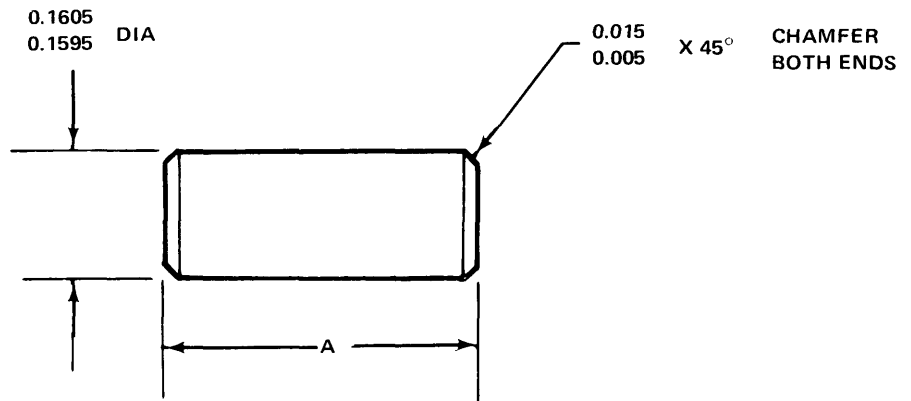


**Figure D-62.** Part Number SP 1705-1 PIN, Solenoid  
Fabricate from: NSN 9510-00-224-1675  
Material:



NOTE:  
1. BREAK SHARP EDGES

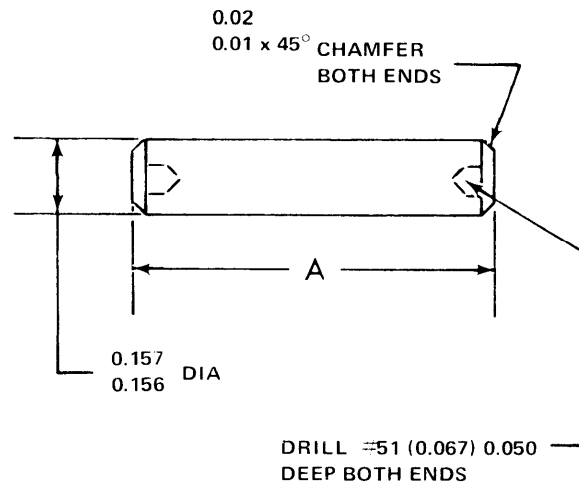
**Figure D-63.** Part Number SP 1706-1 SPACER  
Fabricate from: NSN 9530-00-167-2026  
Material:



DASH NO.	A DIM
.1	0.359
-2	0.390

PART NO.	NAME	STOCK SIZE	MATT.	SPEC.
SP-1707-1	PIN	3/16 DIA X 3/8	4130	COMM.
SP1707-2	PIN	3/16 DIA X 13/32	4130	COMM.

**Figure D-64.** Part Numbers SP 1707-1 AND -2, PIN, Solenoid Linkage  
 Fabricate from: NSN 9510-00-294-9666  
 Material: Metal Bar - Steel, Cold Finish. Federal Specification MIL-S-6758, Comp 4130, 0.375 Inch Dia.

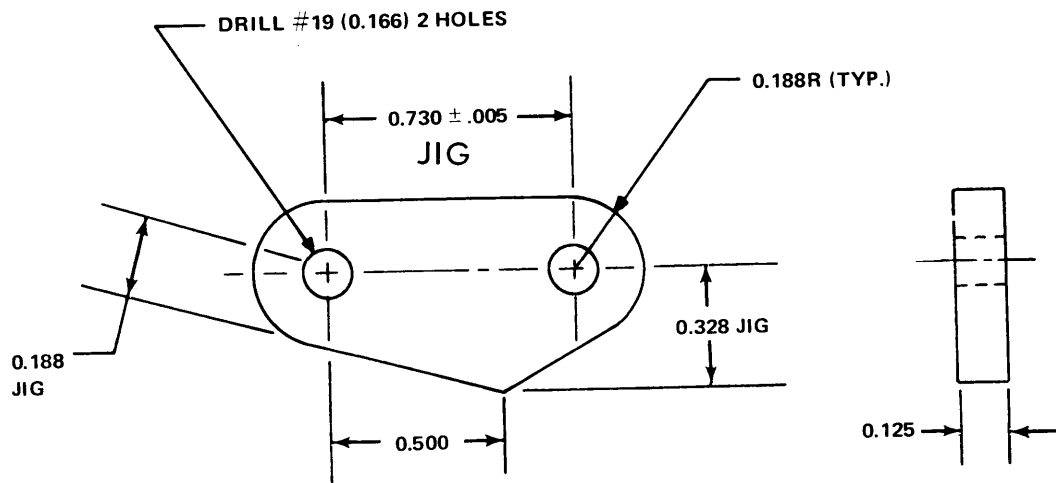


DASH NO.	A DIM.
.2	1.125 1.100

NOTES:

1. DIM'S ARE BEFORE PLATE
2. HEAT TREAT TO ROCKWELL C-25-29
3. CAD. PLATE QQ-P-416 CC. 2 TYPE II

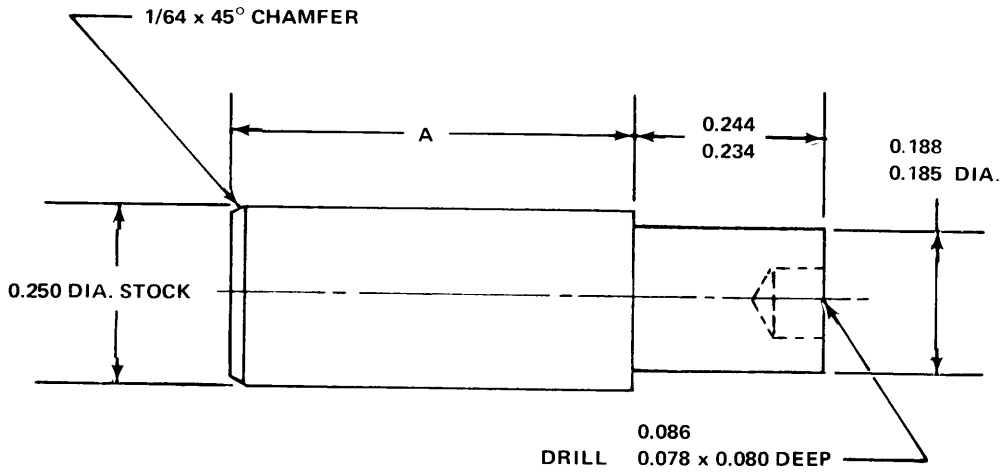
**Figure D-65.** Part Number SP 1709-2 PIN, Shaft & Arm  
 Fabricate from: NSN 9510-00-294-9666  
 Material: Metal-Bar Steel Cold Finished, Federal Specification MIL-S-6758,  
 Comp 4130, 0.375 Inch Dia.



NOTES:

1. BREAK ALL SHARP EDGES 0.005 TO 0.010
2. HEAT TREAT MATERIAL TO ROCKWELL C-25 TO 29
3. CAD. PLATE QQ-P-416 CLASS 2 TYPE II

**Figure D-66.** Part Number: SP 1710-1 LINK SOLENOID  
 Fabricate from: NSN 9515-00-184-8811  
 Material: Metal Strip Steel, Hot Rolled. Federal Specification MIL-S-18729  
 Comp 4130, 0.125 Inch Thick



DASH NO.	A DIM.
-1	0.469

NOTE:  
1. BREAK SHARP EDGES 0.005 TO 0.010

Figure D-67.

Part Number SP 1715-1 PIN, Stop  
Fabricate from: NSN 9510-00-618-8926  
Material:

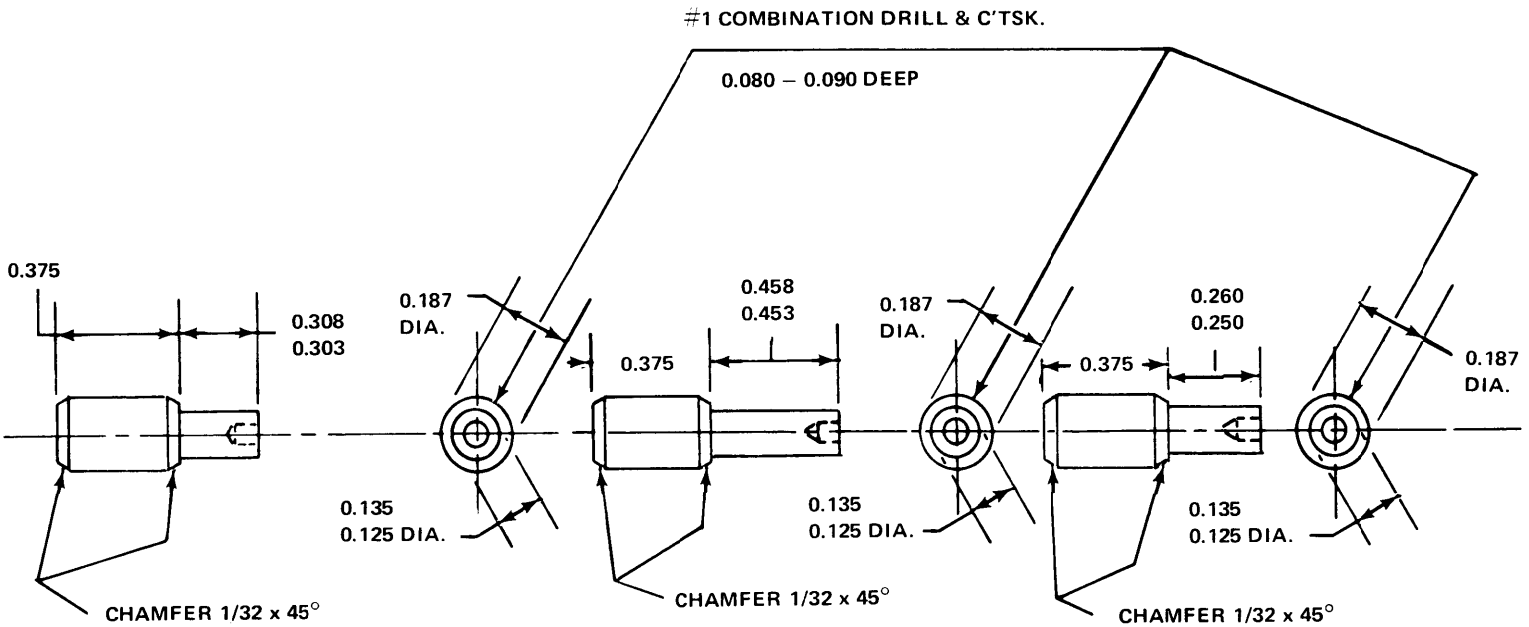


Figure D-68.

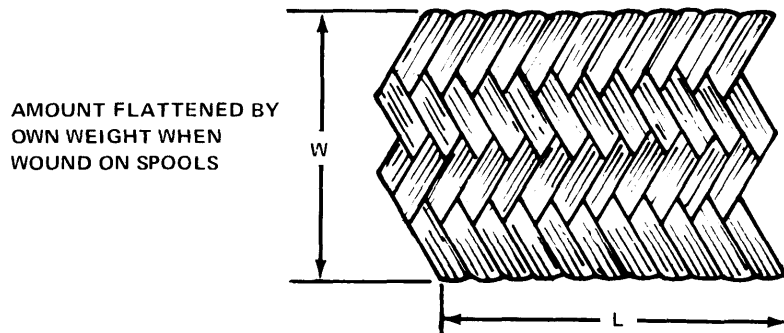
Part Number SP 3184-4 DOWEL PIN

SP 3184-5

SP 3184-6

Fabricate from: NSN 9510-00-596-2016  
Material:

D-113



ENGINEERING INFORMATION								
DASH NO.	4	7	8	11	13	24	32	50
SIZE DESIGNATION APPROX. INSIDE DIA.	1/16	7/64	1/8	11/64	13/64	3/8	1/2	25/32
NUMBER OF ENDS	48	96	120	168	312	384	528	864
SIZE OF INDIVIDUAL WIRES (A.W.G.)	36	36	36	36	36	36	36	36

NOTES: 1. BRAID MUST CONFORM TO SPEC. QQ-B-575  
 CODE: FIRST DASH NUMBER INDICATES NOMINAL I.D. OF BRAID IN 1/64 IN. INCREMENTS  
 SECOND DASH NUMBER INDICATES LENGTH IN 1/2 IN. INCREMENTS  
 EXAMPLE: 20-036-11-10= FLAT, NOMINAL SIZE 11/64 I.D. 5 INCHES LONG  
 MATERIAL: COPPER WIRE  
 FINISH: TIN PLATE

**Figure D-69.** Part Number 20-036-8-24, BRAID, Wire  
 Fabricate from: NSN 6145-00-628-7753  
 Material:

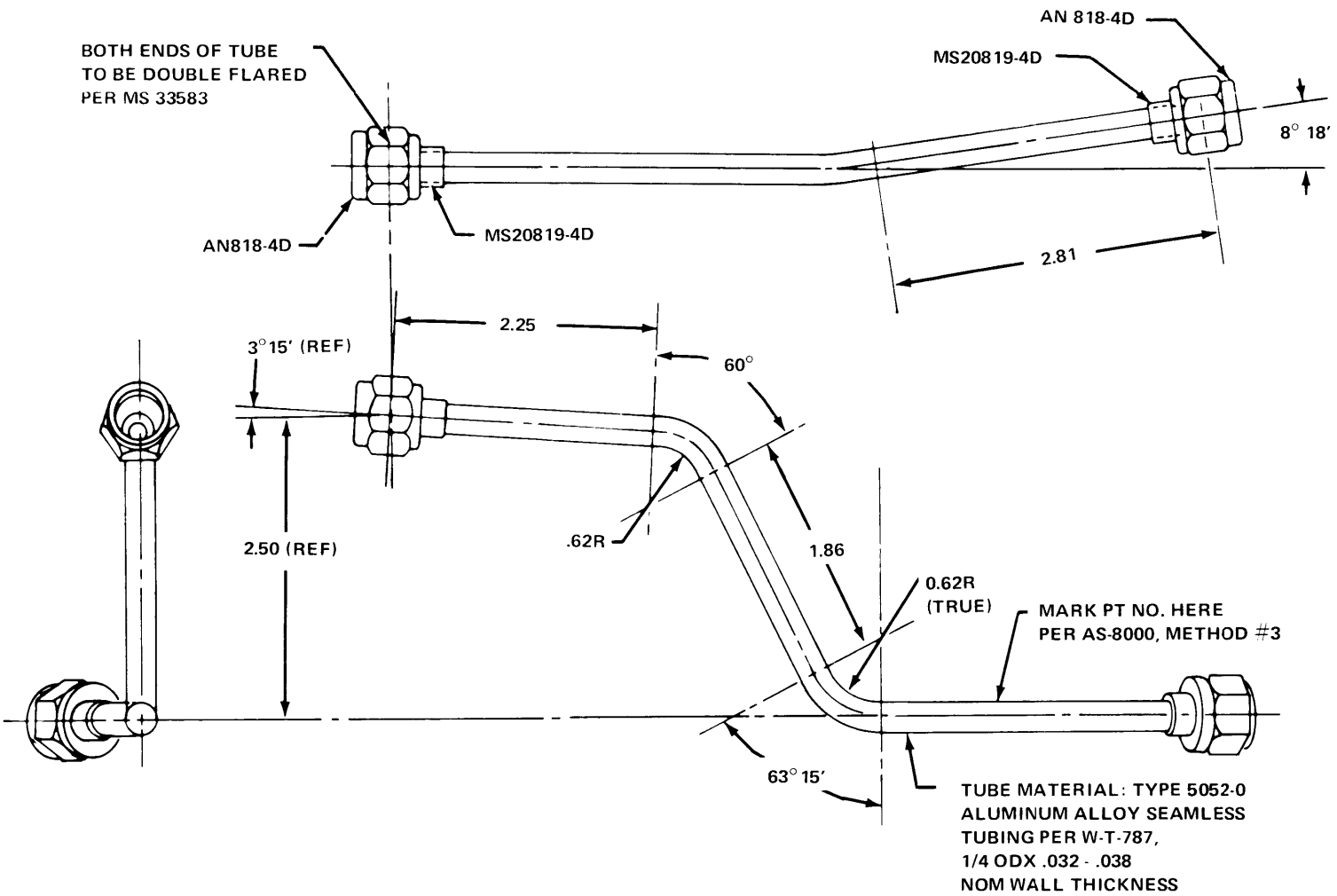
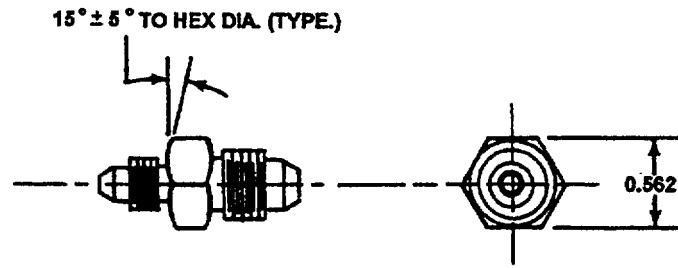


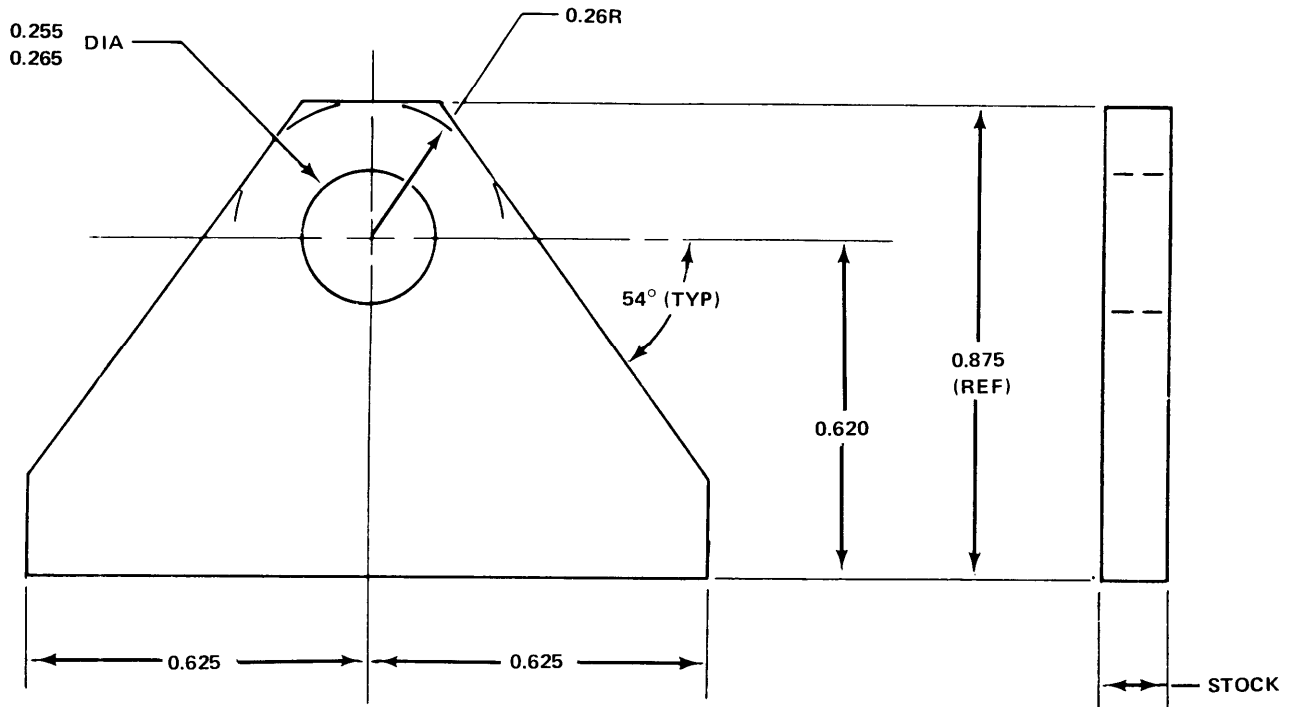
Figure D-70. Part Number 99C29, TUBE, Valve to Valve  
 Fabricate from: NSN 4710-00-278-6398  
 NSN 4730-00-287-0289  
 NSN 4730-00-302-8641  
 Tube Aluminum Alloy, Federal Specification WW-T-700/4, 1/4 inch Diameter OD, 0.035 inch Wall Thickness



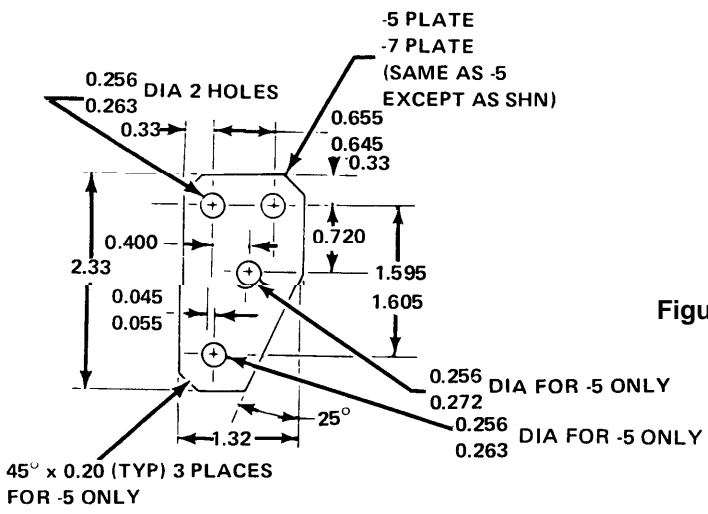
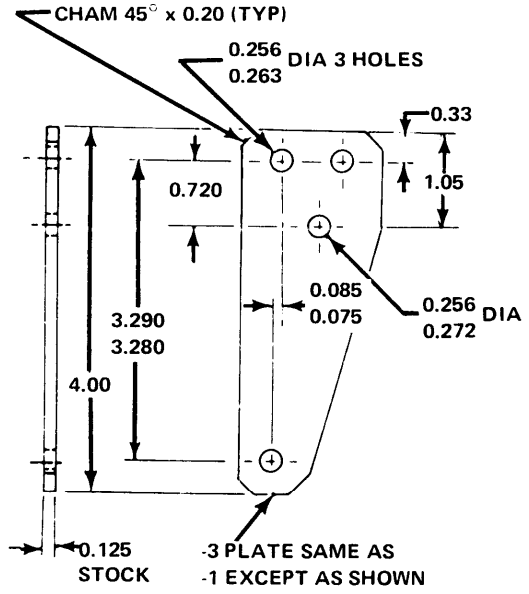
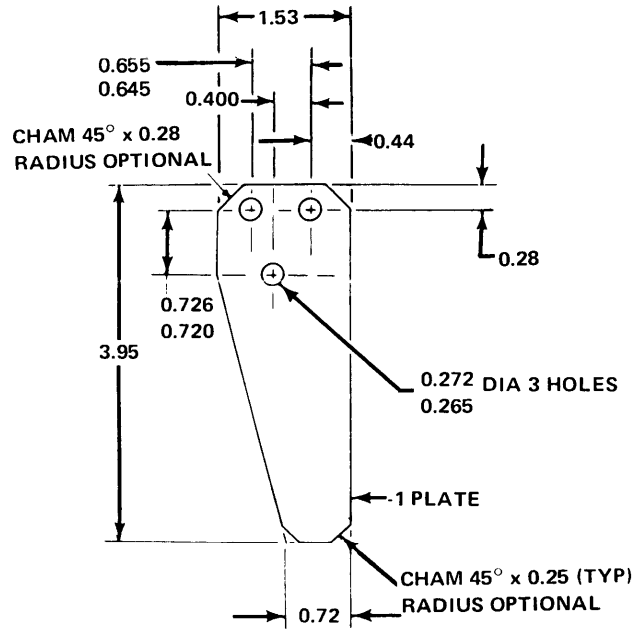


**BREAK ALL SHARP EDGES AND REMOVE ALL BURRS AND SILVERS WHICH MIGHT BECOME DISLODGED UNDER USAGE**

Figure D-71. Part Number AN919-1D (CAGE 88044) REDUCER TUBE  
Fabricate from: NSN 4730-00187-3575  
Finish: Hex Surface 25  
Anodize per MIL-A-8625 Or  
Chem Film Per MIL-C-55541  
(Light Blue Dye).  
Material:



**Figure D-72.** Part Number 204-011-149-1 CLAMP, Strap Retention Nut Main Rotor  
 Fabricate from: NSN 9515-00-204-0220  
 Material: Steel Sheet, Federal Specification MIL-S-18729, Condn, 0.125 Inch Thick



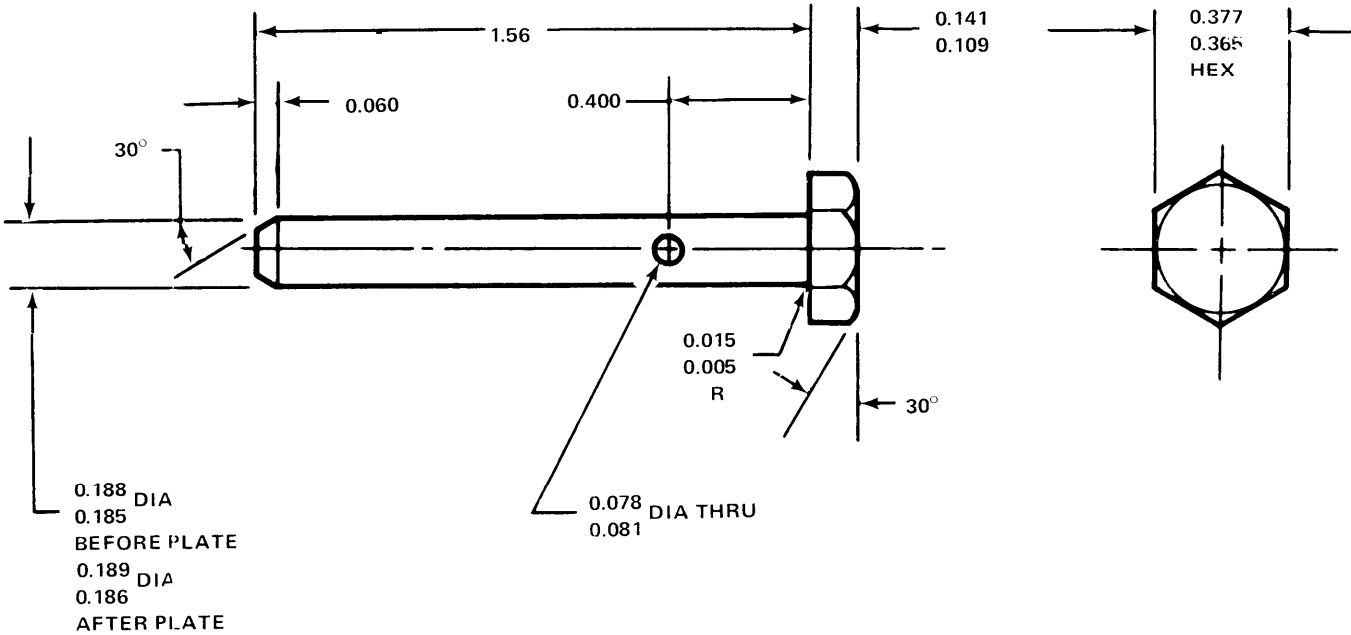
NOTES:  
1. BREAK EDGES 45° x 0.025 OR 0.025R  
EXCEPT AS SHOWN

Figure D-73. Part Number

- 024-011-458-1 SWASHPLATE
- 204-011-458-3
- 204-011-458-5
- 204-011-458-7

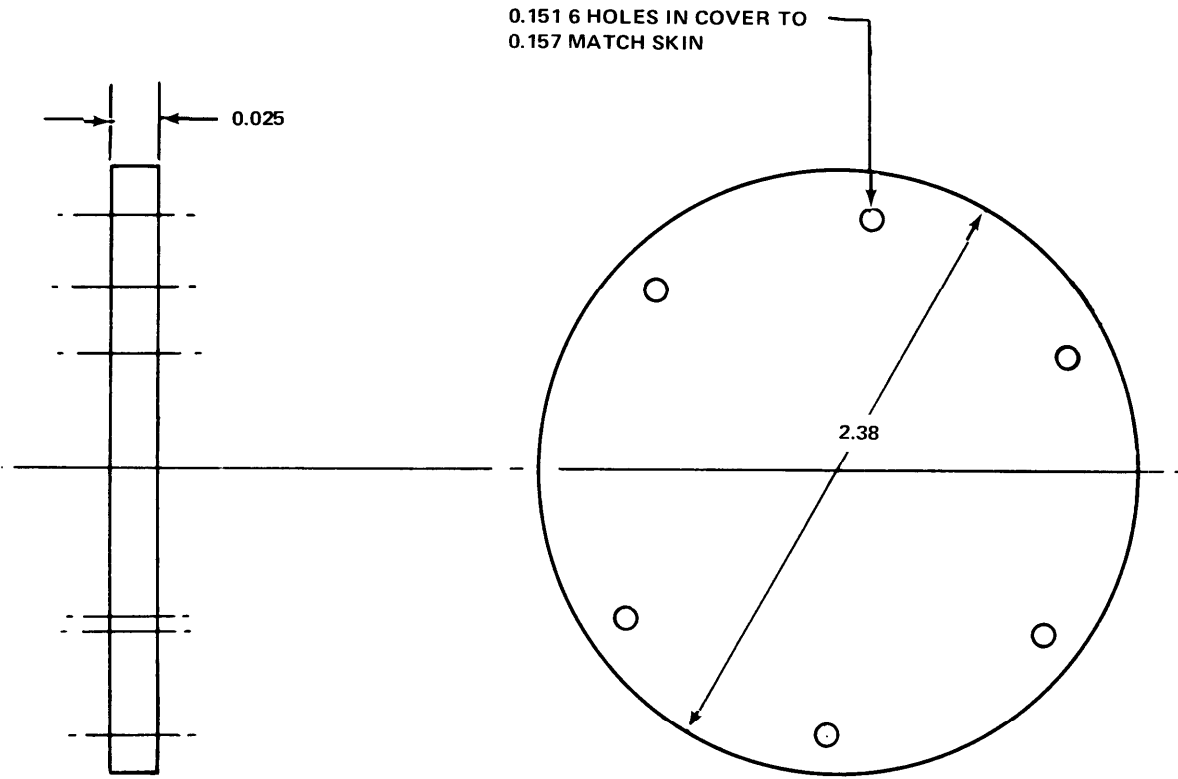
Fabricate from:  
Material:

NSN 9535-00-232-0418  
2024 AL ALY Sheet, Federal Specification  
QQ-A-250/5, T3, 0.125 Inch Thick



- NOTES:
- MARK PER BPS FW B 4050
  - 1. BREAK EDGES 0.015 X 45° OR 0.015R UNLESS OTHERWISE NOTED
  - 2. ALT. MATL: MAY BE MADE FROM AN3-21A (OR LONGER) BOLT. MARKINGS ON BOLT HEAD TO BE REMOVED

Figure D-74. Part Number 204-012-110-1 BOLT  
Fabricate from: NSN 5306-00-182-2010  
Material: 4130 STL/MIL-S-6758 HT-125-145KSI  
Cad Plate CB1



**Figure D-75.**

Part Number	204-030-800-443	Cover Tail Boom Assembly
Fabricate from:	NSN 9535-00-167-2278	
Material:	2024 AL ALY Federal Specification QQ-A-250/5, 0.0250 Inch Thick	

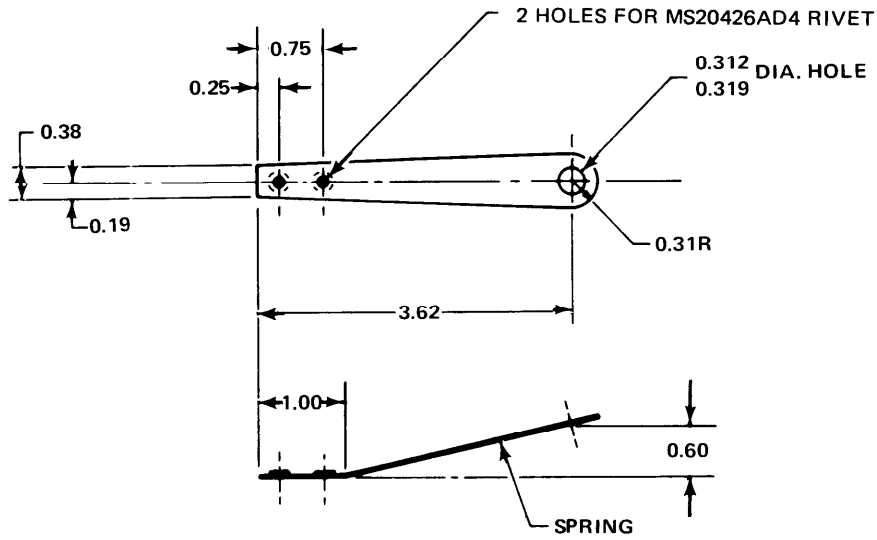
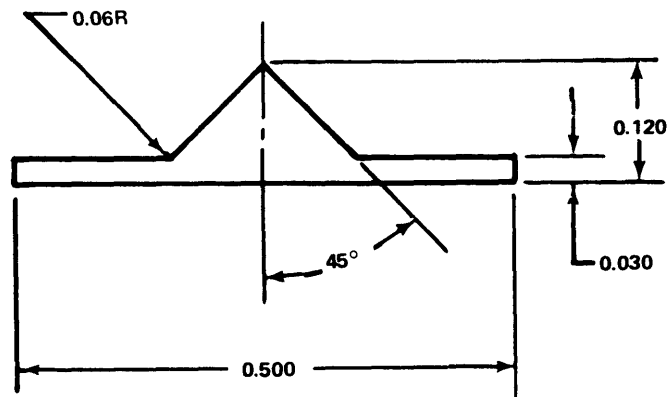
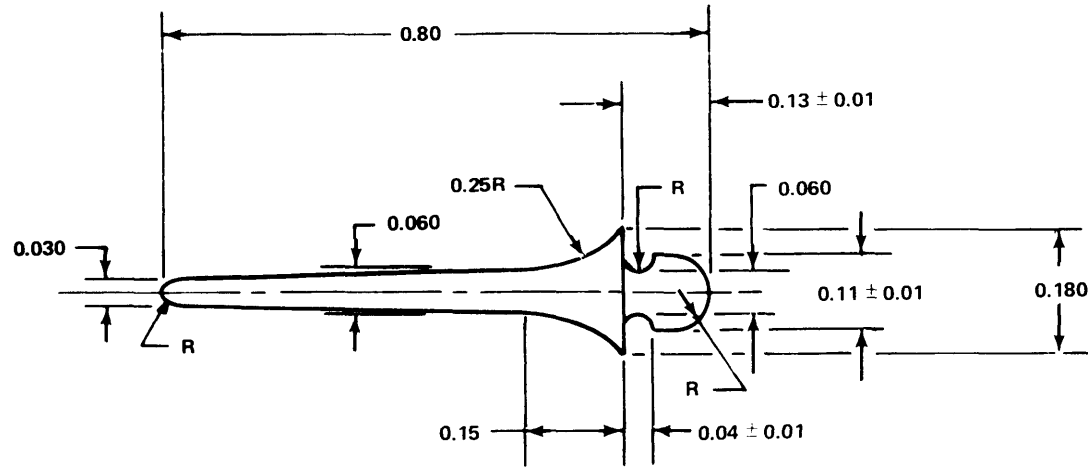


Figure D-76. Part Number 204-030-437-3 SPRING  
 Fabricate from: NSN 9515-00-684-6944  
 NSN 5325-00-141-4002  
 NSN 5325-00-721-5503  
 Material: Metal Strip Steel Hot Rolled, Federal Specification MIL-S-7947,  
 0.020 Inch Thick



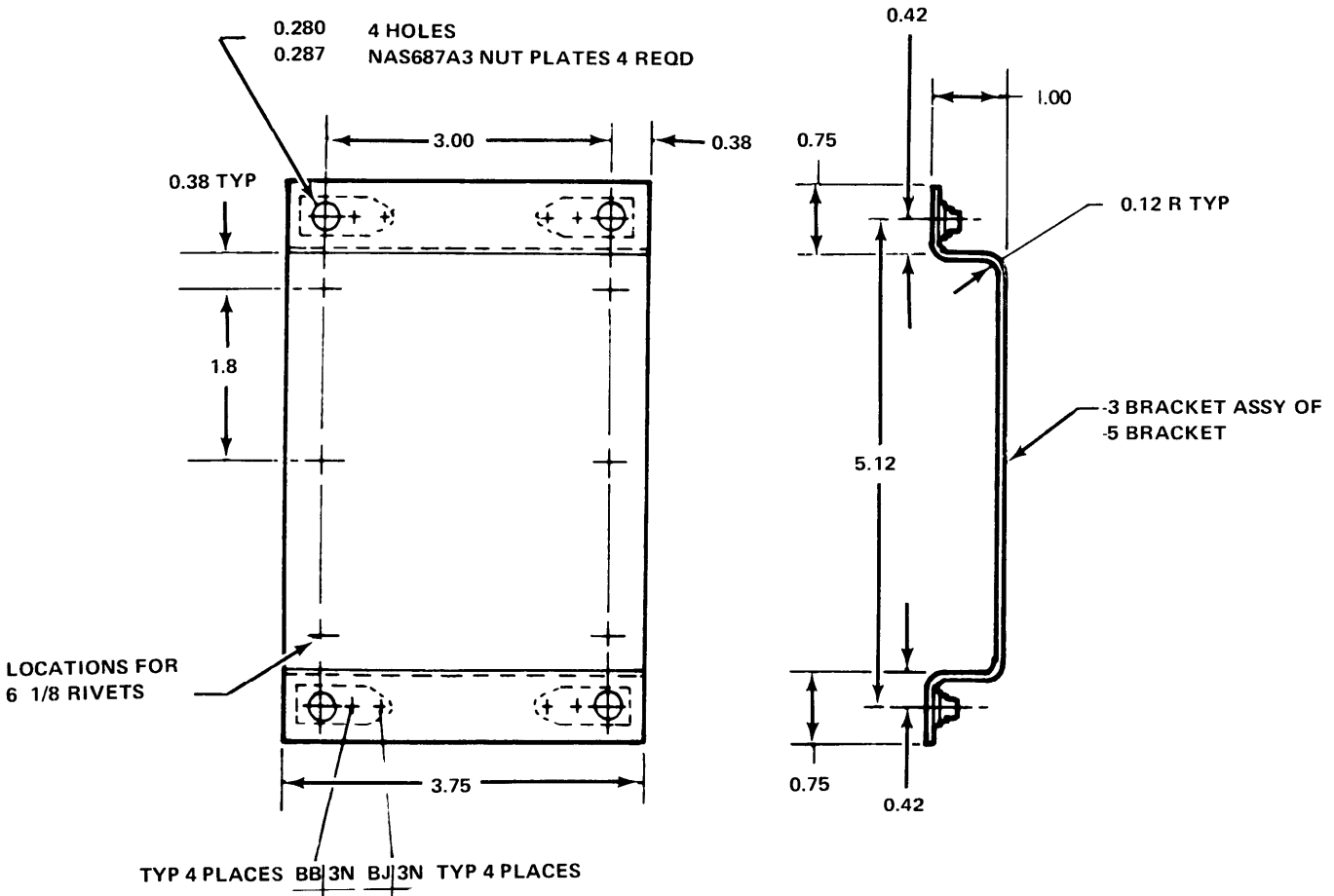
**Figure D-77.** Part Number 204-031-003-13,-14 Rubber Seal  
Fabricate from: NSN 9320-00-759-9758  
Material: LG. Rubber, 105.0 Inch Length



PART NUMBER	NOMENCLATURE	FABRICATE FROM NSN	LENGTH
204-031-003-23	SEAL	5340-00-949-8281	49 IN.

Figure D-78.





NOTE:  
1. ZINC CHROMATE FINISH

Figure D-79. Part Number 204-031-139-3 BRACKET ASSY  
Fabricate from: NSN 9535-00-085-9729, 4 EA 5310-00-778-9480  
Material: 2024 AL ALY Federal Specification QQ-A-250/5,  
0.032 Inch Thick

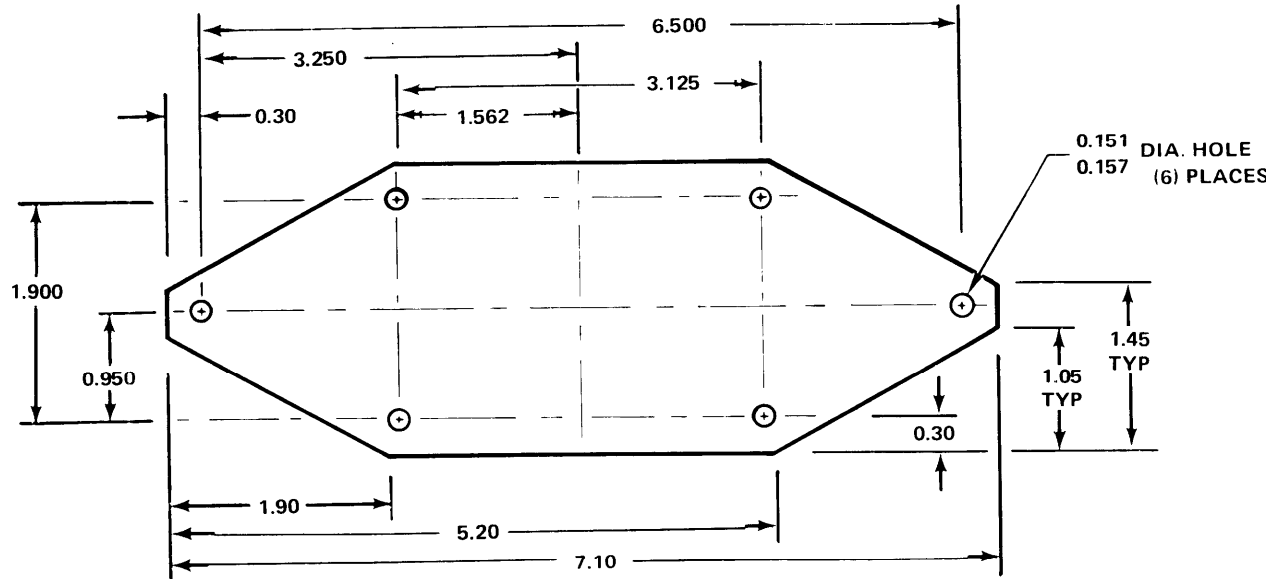


Figure D-80. Part Number 204-031-251-1 COVER PLATE, Antenna Cutout  
 Fabricate from: NSN 9535-00-086-9789  
 Material: 2024 AL ALY Federal Specification QQ-A-250/5,  
 0.032 Inch Thick

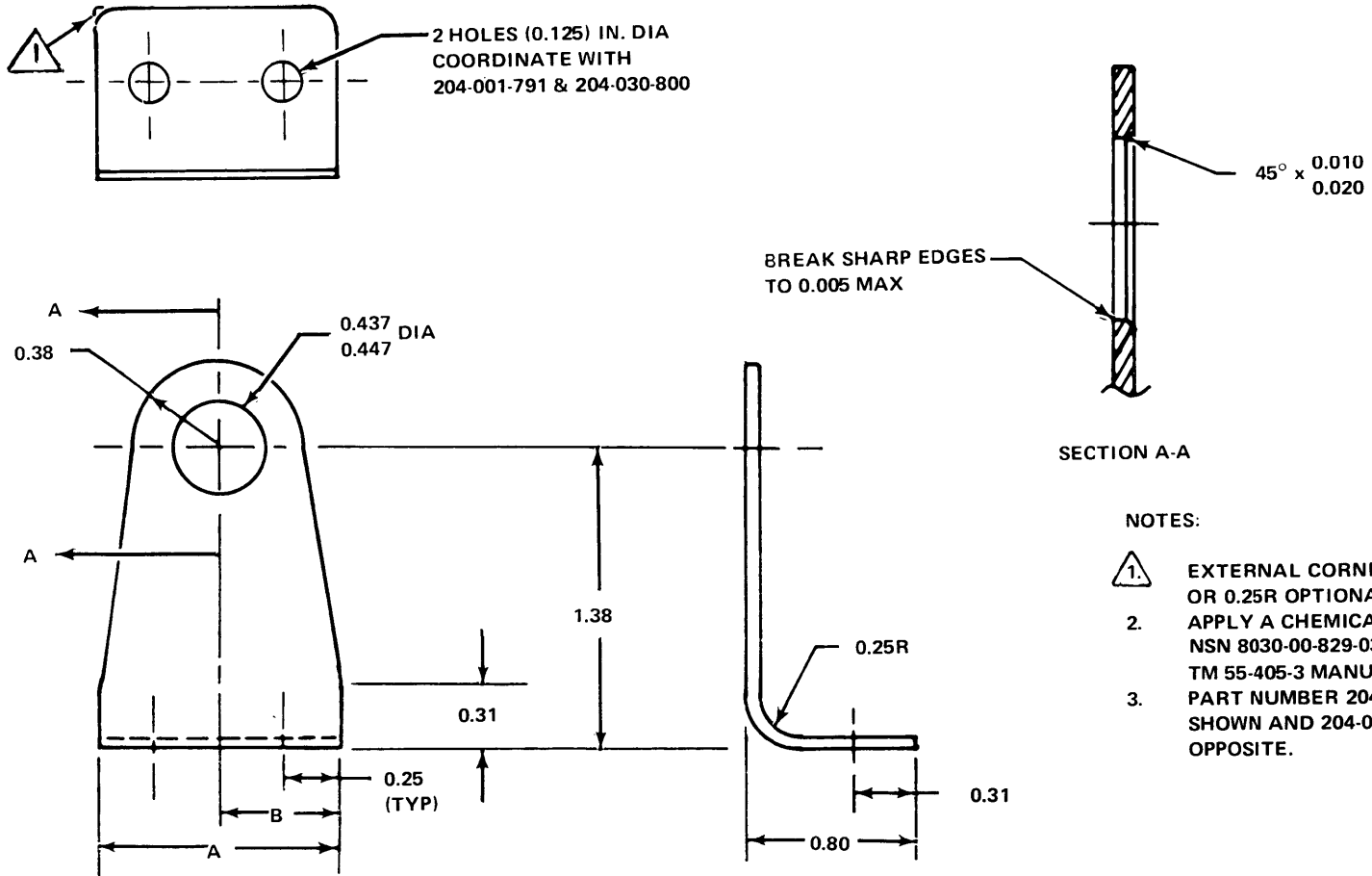


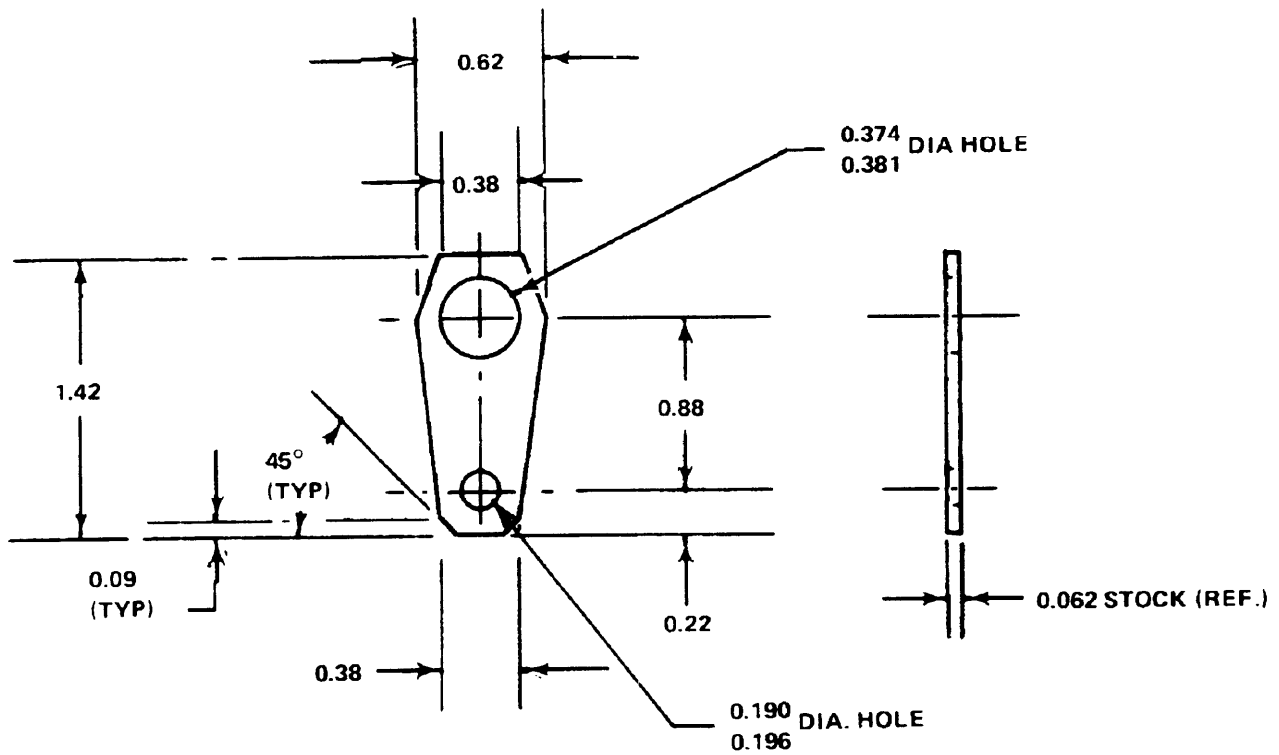
Figure D-81.

PART NUMBER	DIM A	DIM B
204-001-790-1	1.12	0.56
204-001-849-1	1.31	0.80
204-001-849-2	1.31	0.80

Figure D-81.

Part Numbers ~ 204-001-790-1 SUPPORT  
204-001-849-1  
204-001-849-2

Fabricate from: NSN 9535-00-232-0376  
Material: 2024 AL ALY, Federal Specification  
QQ-A-250/5, 0.063 Inch Thick

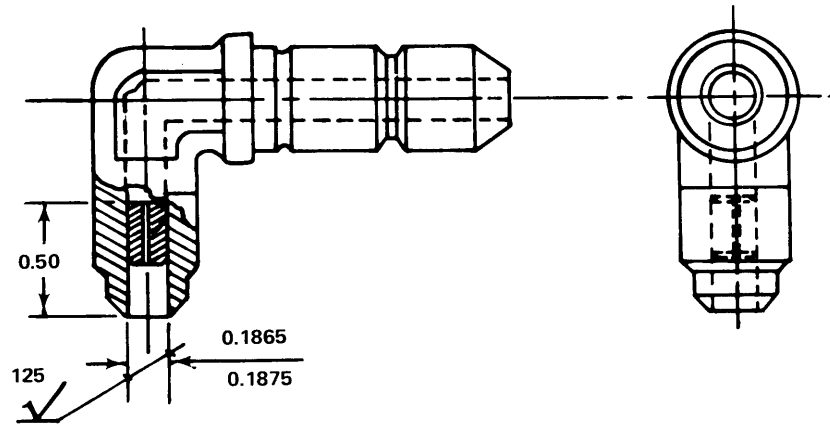


NOTES:  
 BREAK SHARP EDGES 0.015 x 45° CHAMFER

Figure D-82. Part Number 204-040-732-I Strap, Support  
 Fabricate from: NSN 9515-00-683-9294 on  
 P/N204-040-732-I Clip  
 Material: Metal Strip Steel, Federal Specification MIL-S-7947, 0.020 Inch Thick

Figure D-83. DELETED





**Figure D-84.** Part Number 204-060-031-15 RESTRICTOR, Fitting  
Fabricate from: NSN 9510-00-243-7626 and 4730-00-231-3026  
Material:

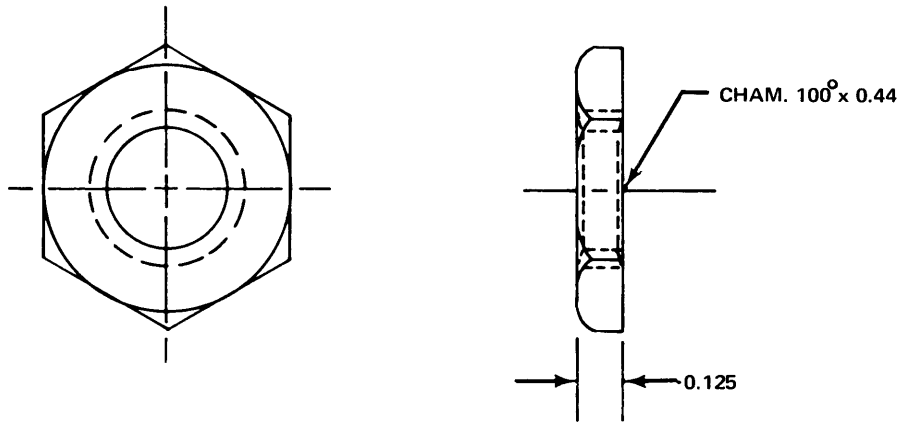
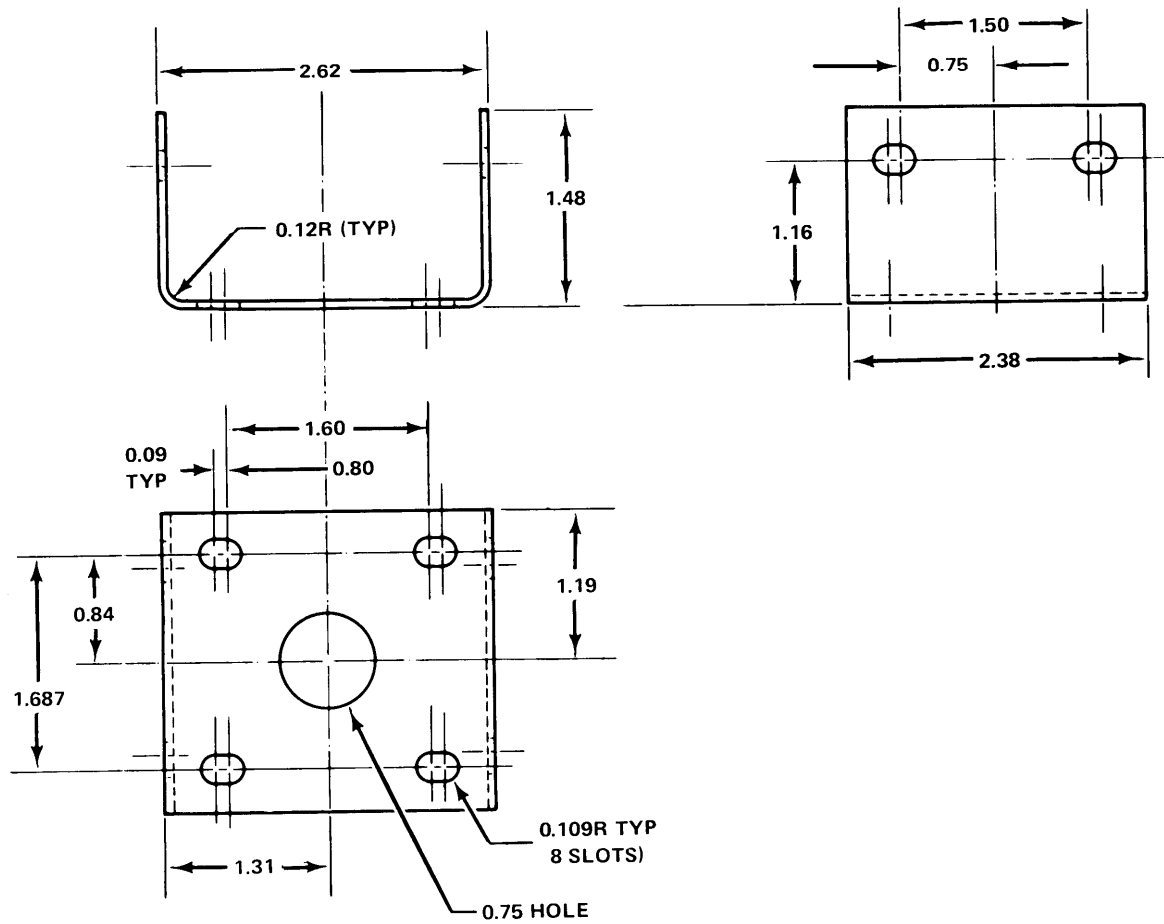
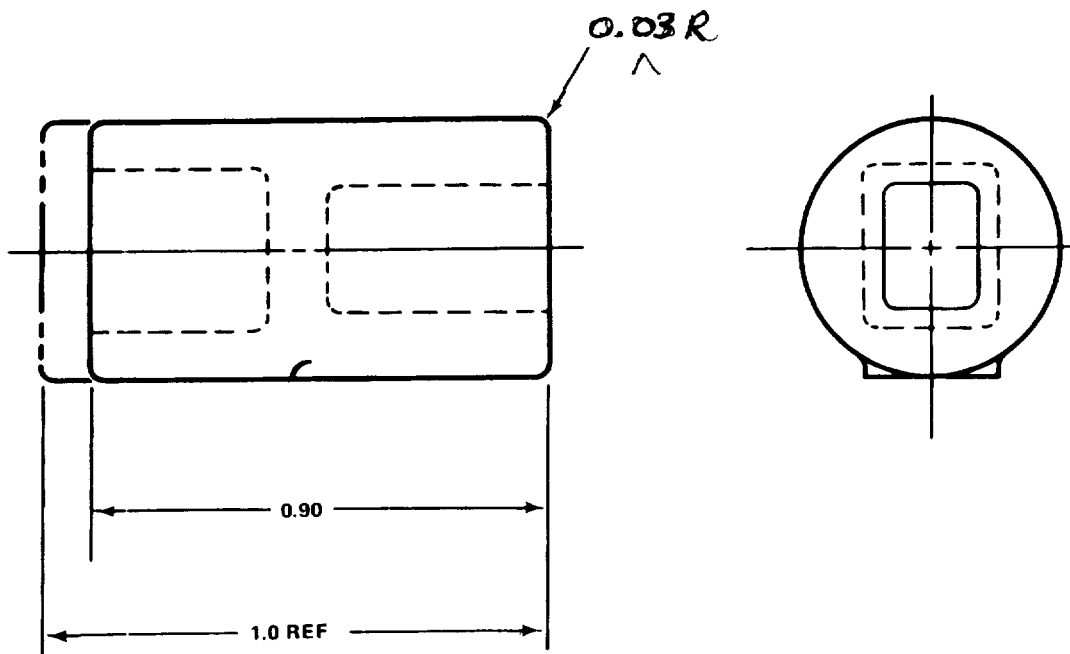


Figure D-85. Part Number 204-060-056-1 NUT, Pressure Switch Support  
Fabricate from: NSN 5310-00-208-5769  
Material: Steel, Cadmium Plated



**Figure D-86.** Part Number 204-070-175-1 MOUNT, Valve Control, Heating  
 Fabricate from: NSN 9535-00-232-0378  
 Material: 2024 AL ALY Sheet, Federal Specification QQ-A-250/5, 0.063 Inch Thick





**Figure D-87.** Part Number 204-070-185-1 CONNECTOR, Valve Selector, Bleed Air  
Fabricate from: NSN 1660-00-736-1007  
Material: Adapter, Aluminum Alloy Casting

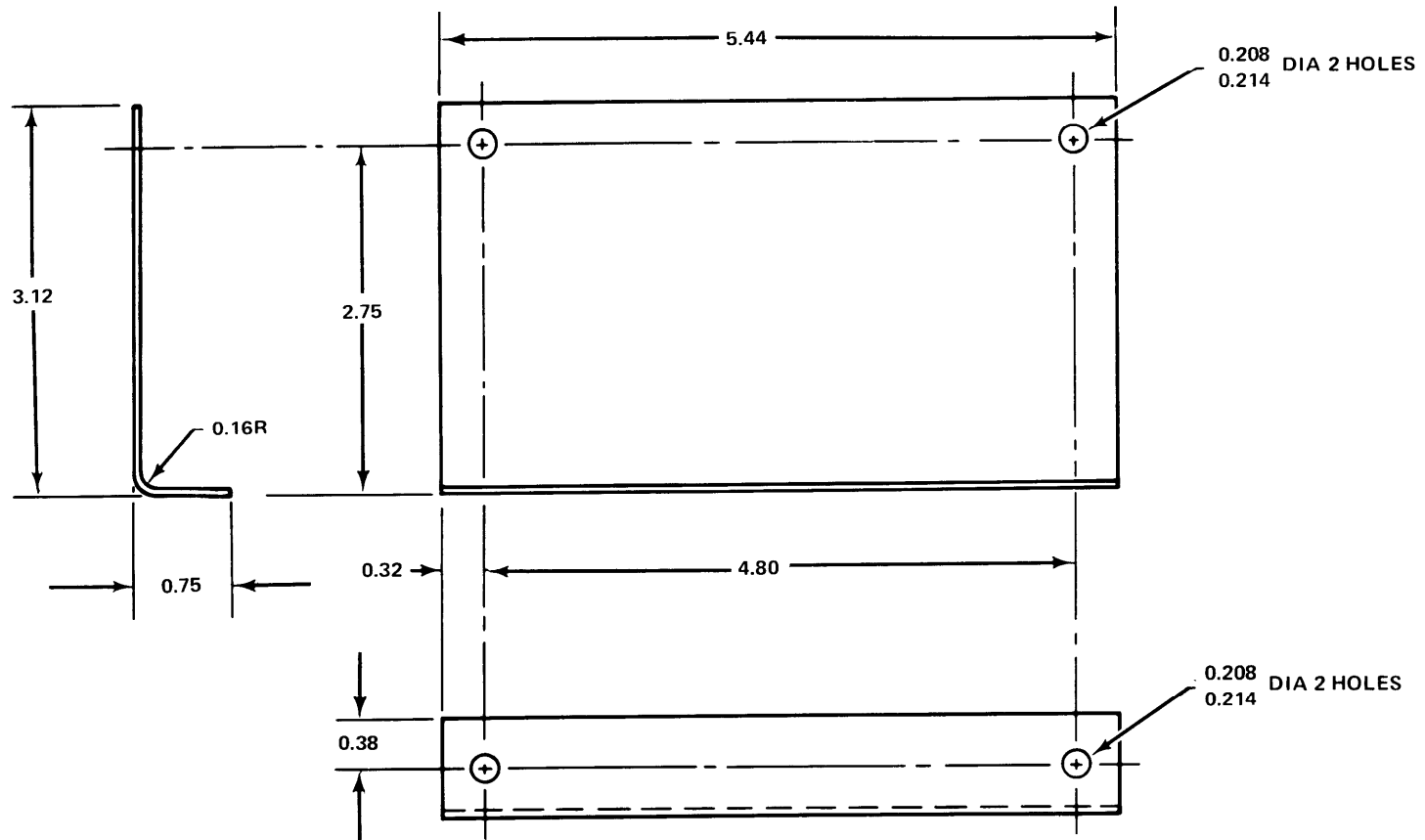
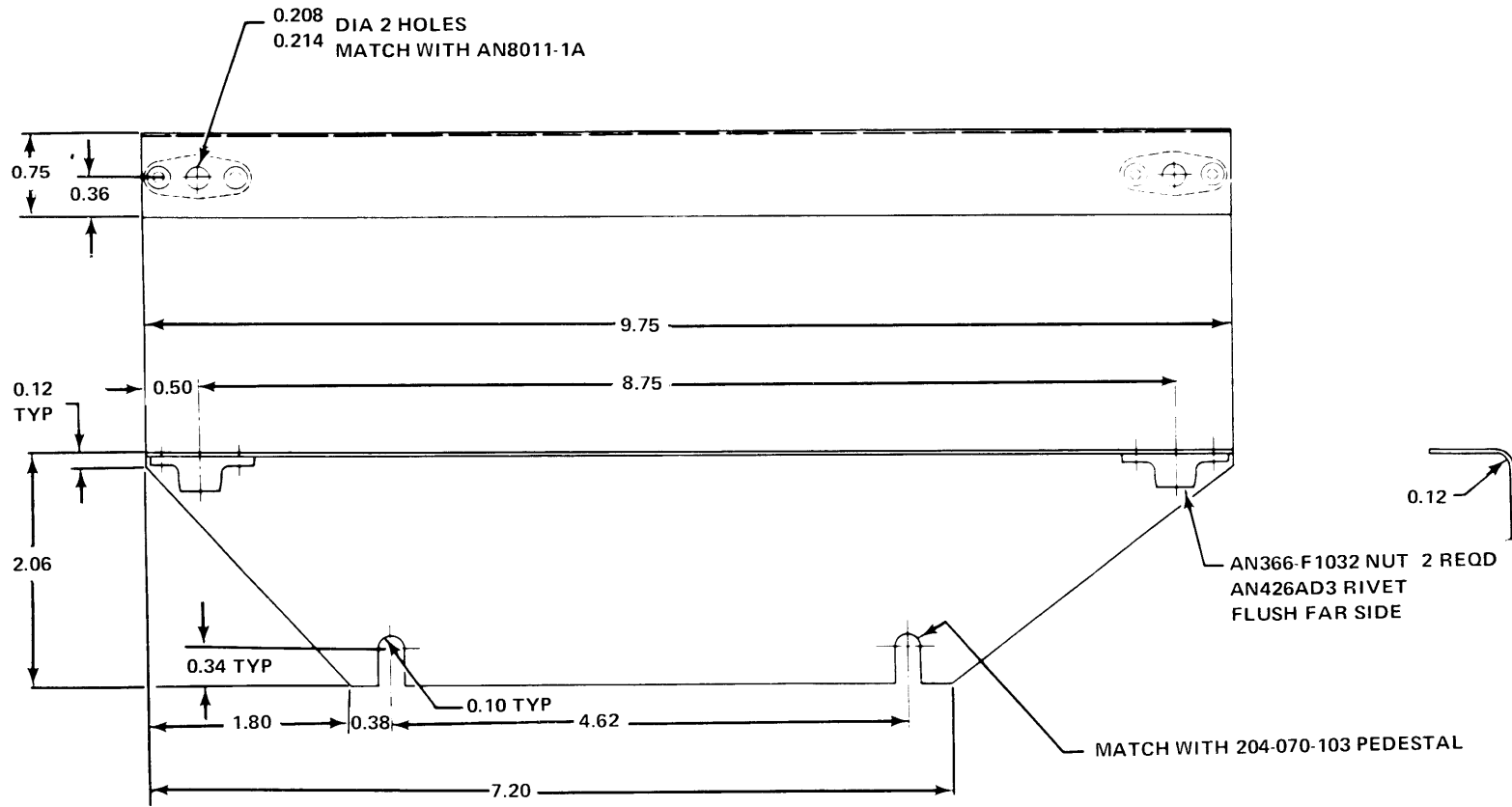


Figure D-88.

Part Number  
Fabricate from:  
Material:

204-070-230-1 BRACKET, Valve, Heating and Bleed Air  
NSN 9535-00-167-2280  
2024 AL ALY Sheet, Federal Specification QQ-A-250/5, 0.040 Inch Thick



PART NUMBER	NAME	FABRICATE FROM:
204-070-255-3	BRACKET	NSN 9535-00-167-2279
NAS697A3	NUT	NSN 5310-00-275-4364
MS20426AD3	RIVET	NSN 5320-00-117-6938

Figure D-89. Part Number 204-070 -255-1 & 2 BRACKET, Map & Data Case

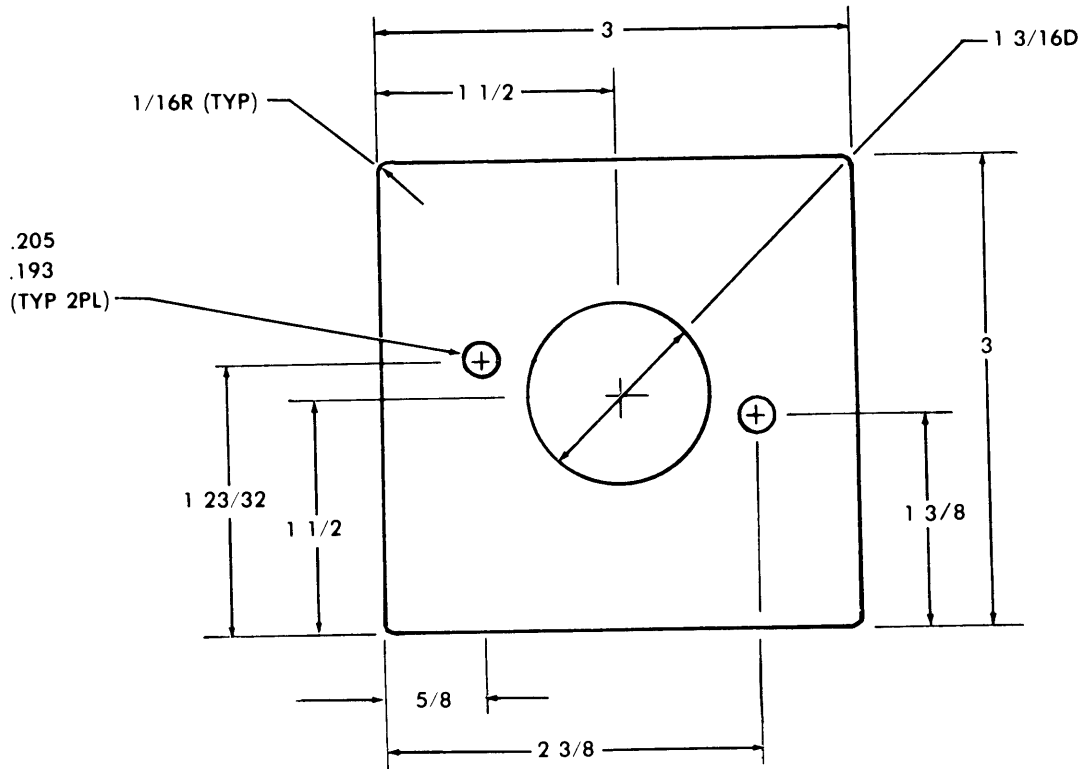
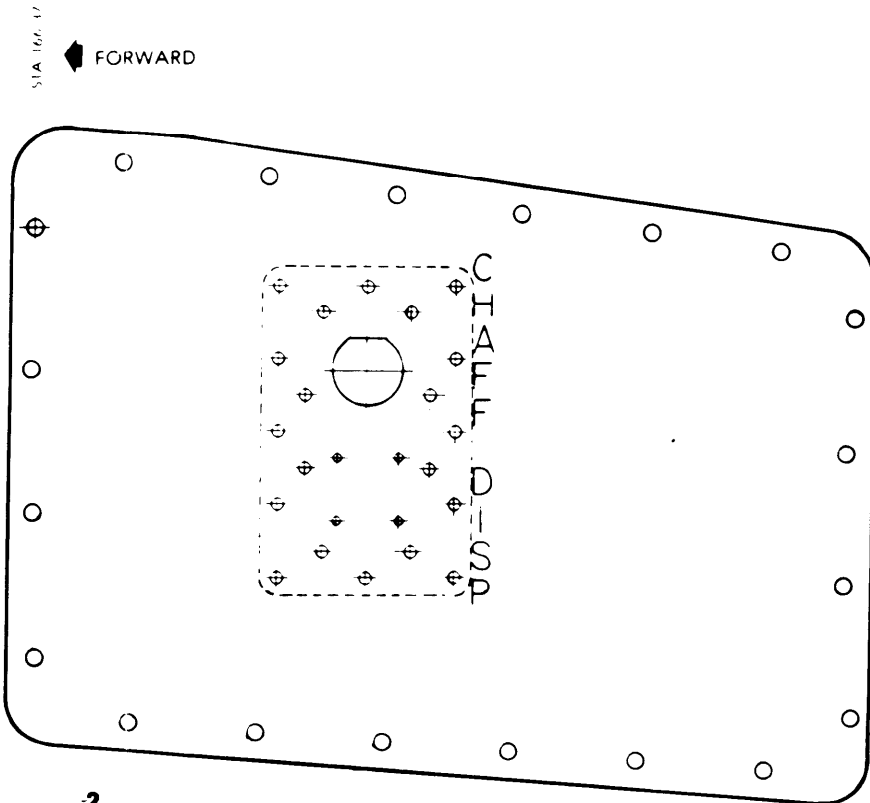
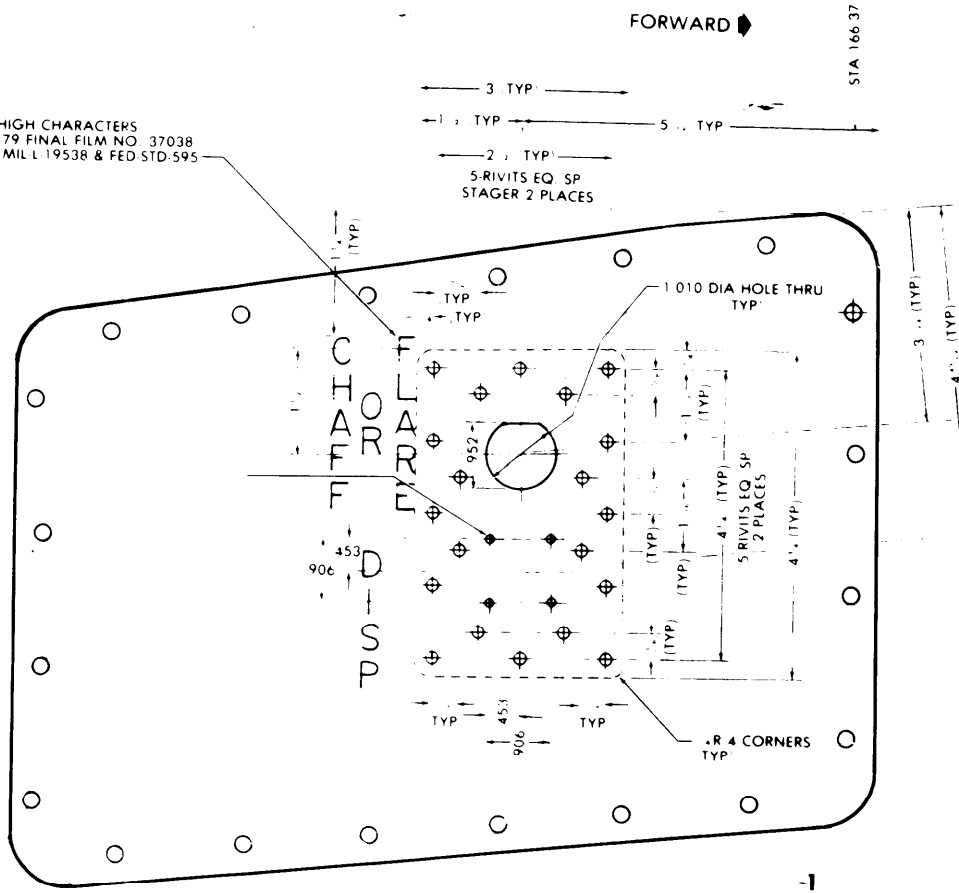


Figure D-90. Plate, Structural, Aircraft, PN ES-B-220316  
 Fabricate from: NSN 9535-00-232-0565  
 Material: .032 x 3 x 3 AL ALY, 2024-T3, QQ-A-250/5

STENCIL : HIGH CHARACTERS  
 PER MIL-F-7179 FINAL FILM NO. 37038  
 BLACK PER MIL-L-19538 & FED STD. 595



**-2** Figure D-91. Access Panel, Assy PN ES-D-221175  
 Fabricate from: NSN 9535-232-1882  
 Material: AL ALY, sheet, .063 THK., 6061-T6, QQ-A-250/11

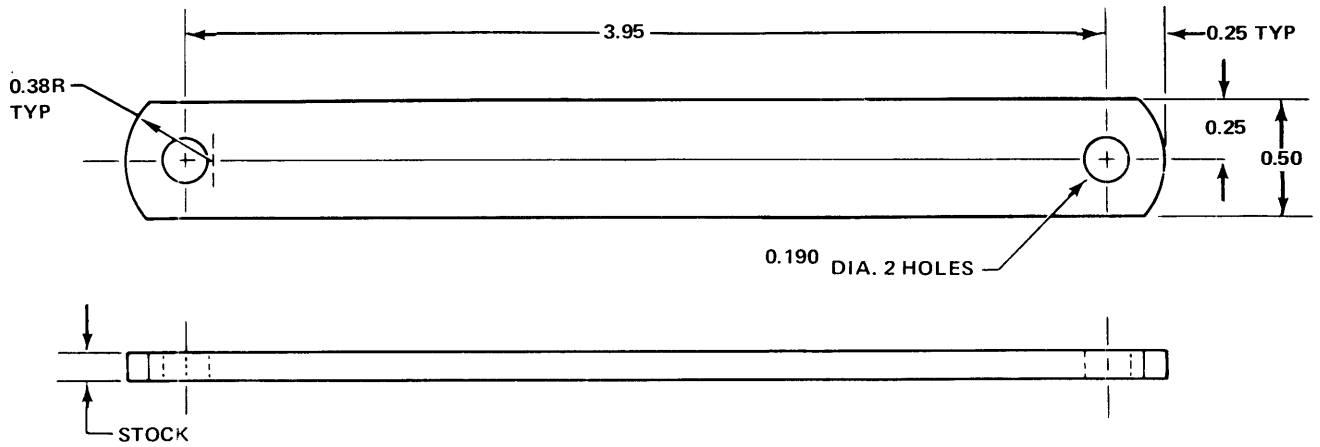
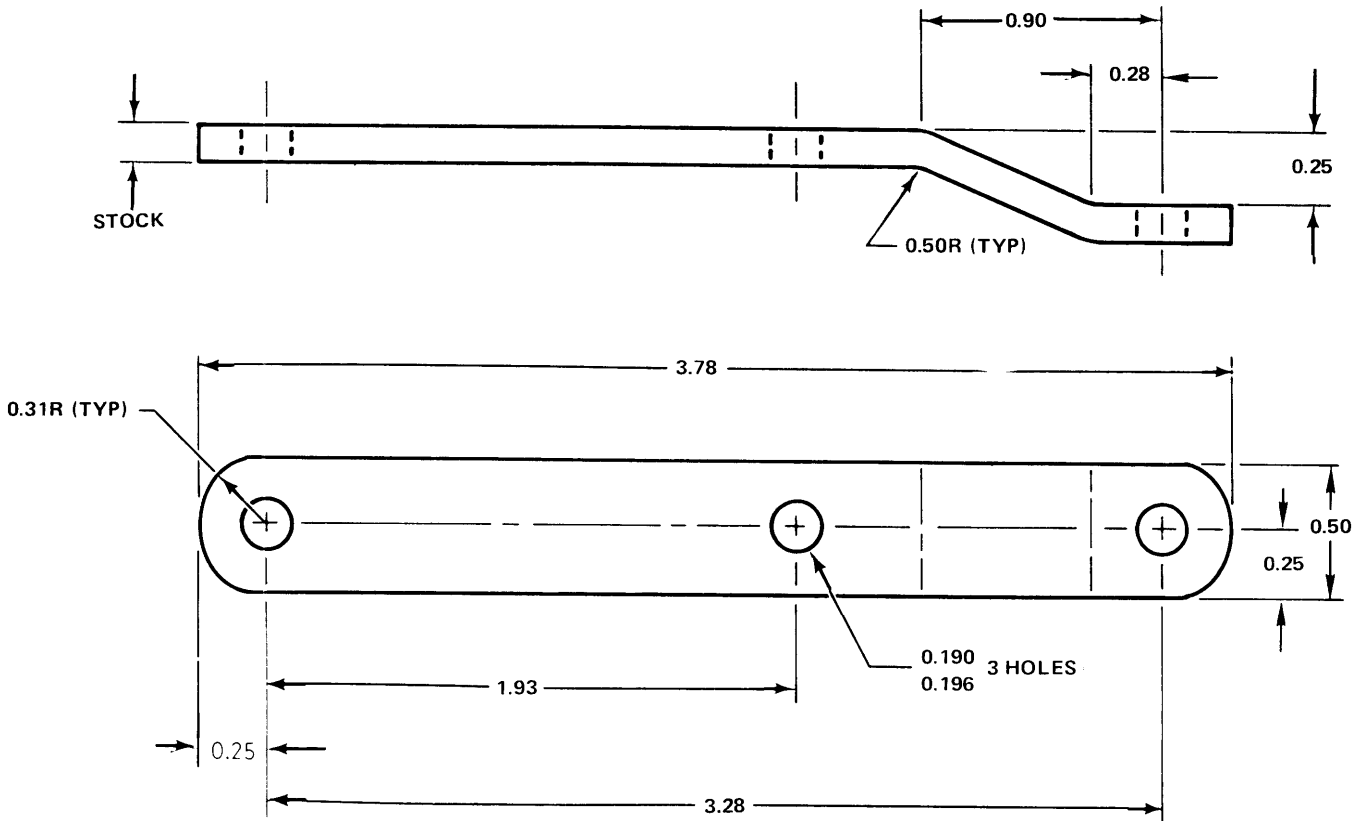
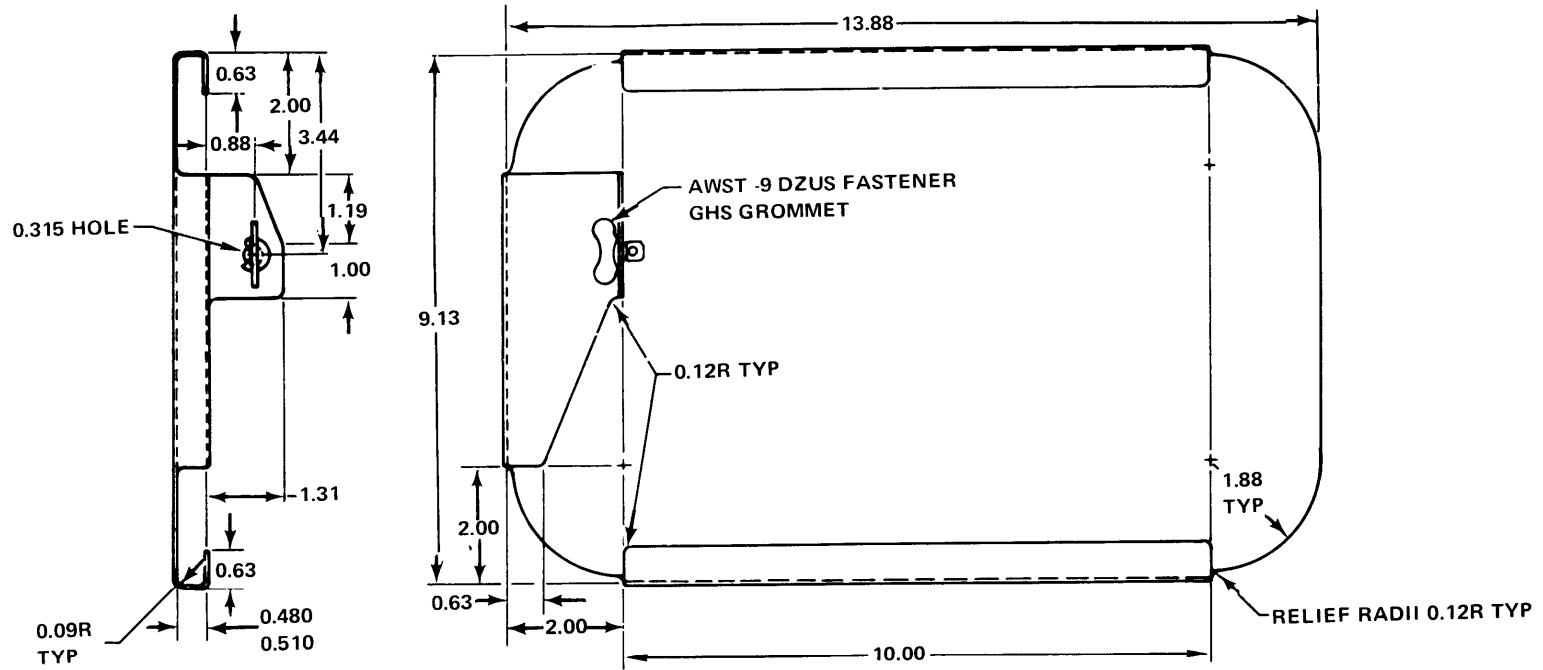


Figure D-92.

Part Number 204-070-274-1 LINK, Control to Bellcrank, Defrost  
Fabricate from: NSN 9535-00-232-0418  
Material: 2024 AL ALY Sheet, Federal Specification, QQ-A-250/5, 0.125 Inch Thick



**Figure D-93.** Part Number 204-070-275-1, BELLCRANK, Heating and Defrost Control  
 Fabricate from: NSN 9535-00-232-0418  
 Material: 2024 AL ALY Sheet, Federal Specification, QQ-A 250/5, 0.125 Inch Thick



PART NUMBER	NAME	FABRICATE FROM:
204-070-528-3	PLATE	NSN 9535-00-167-2278
AW5T9	FASTENER	NSN 5325-00-838-8804
GH5	GROMMET	NSN 5325-00-141-4002

Figure D-94. Part Number 204-070-528-1 COVER ASSEMBLY, Cargo Hook Mirror



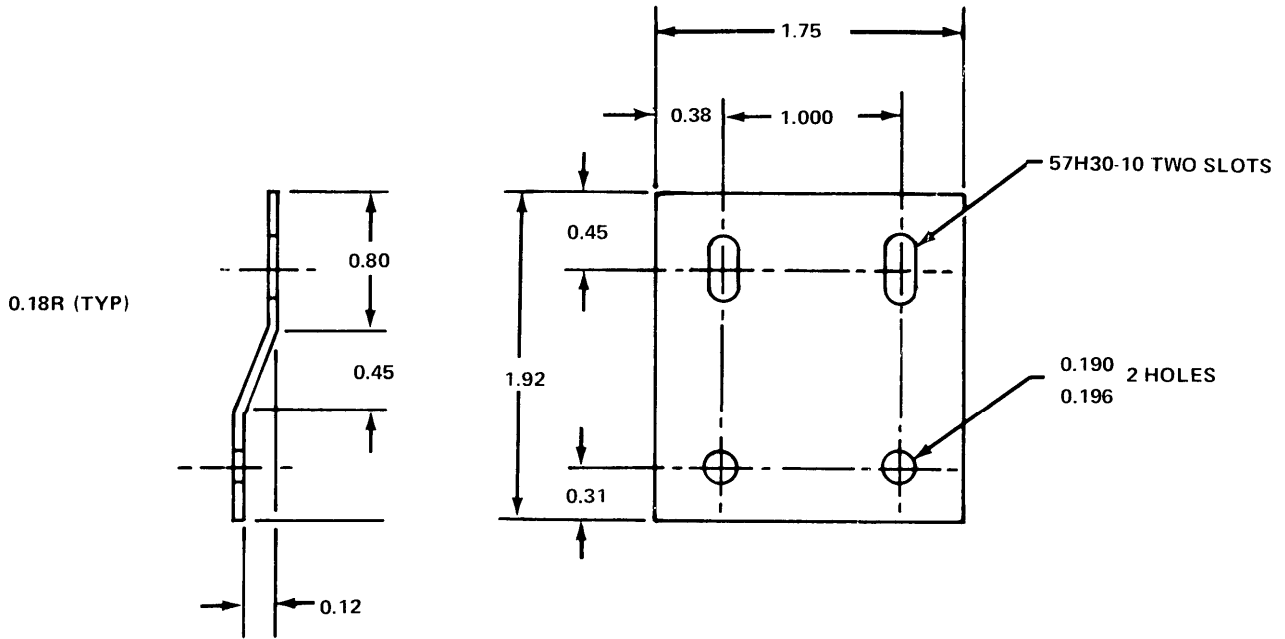
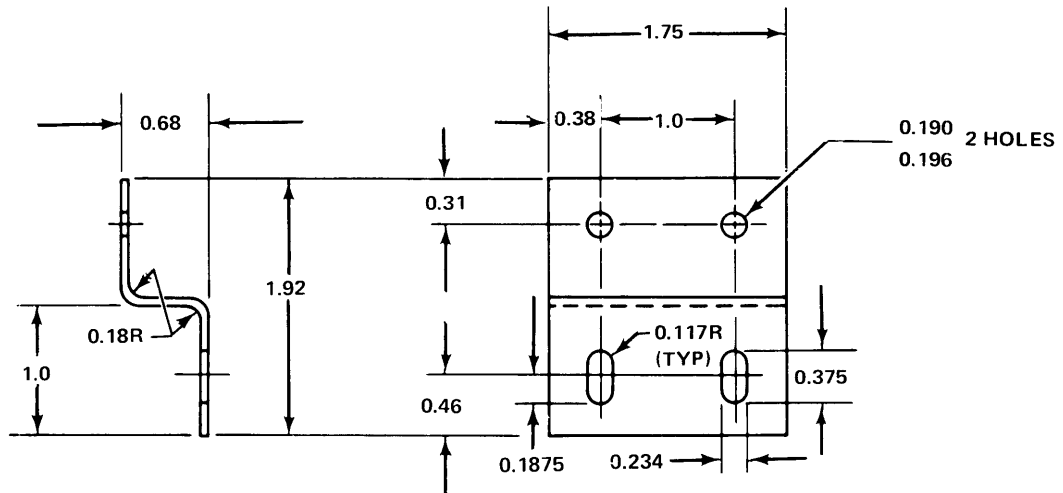


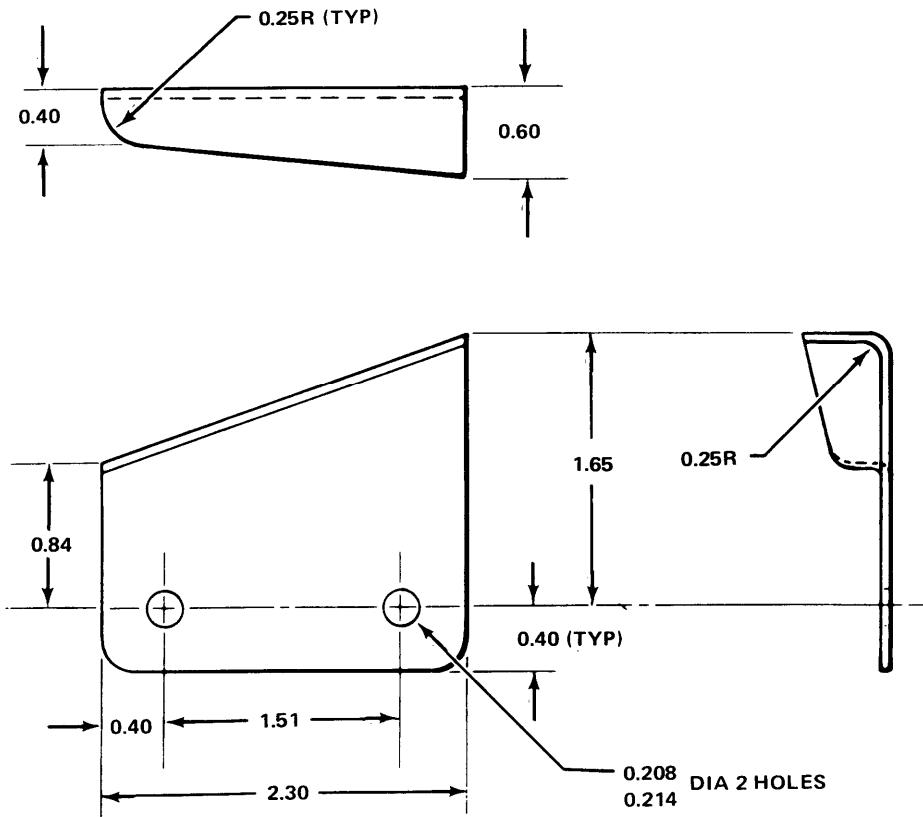
Figure D-95. Part Number  
Fabricate from:  
Material:

204-070-583-1 BRACKET, Upper Switch  
NSN 9535-00-640-2311  
2024 AL ALY Sheet, Federal Specification QQ-A-362,  
0.050 Inch Thick

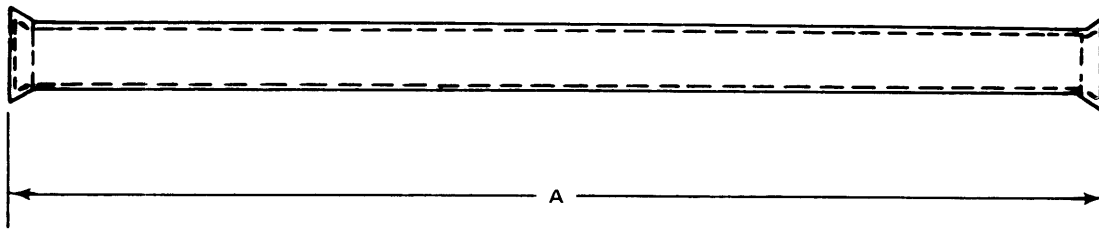


**Figure D-96.** Part Number 204-070.585-1 BRACKET, Lower Switch Bleed Air & Heating  
 Fabricate from: NSN 9535-00-640-2311  
 Material: 2024 AL ALY, Sheet Federal Specification, QQ-A-362.  
 0.050 Inch Thick





**Figure D-98.** Part Number 204-071-539-3 STOP, Emergency Jettison  
 Fabricate from: NSN 9535-00-232-0378  
 Material: 2024 AL ALY Sheet, Federal Specification QQ-A-250/5, 0.063 Inch Thick



PART NUMBER	FABRICATE FROM NSN	DIM A	OD	NOTES
204-071-577-1	4710-00-278-8727	8.50	5/16	2, 3, 4
205-072-222-1	4710-00-279-0910	15.25	5/8	2, 3, 4

NOTES:

1. DOUBLE FLARE ENDS OF TUBE PER TM 55-405-7 MANUAL.
2. SINGLE FLARE ENDS OF TUBE PER TM 55-405-7 MANUAL.
3. APPLY A CHEMICAL FILM NSN 8030-00-829-0376 PER TM 55-405-3 MANUAL.
4. APPLY ONE COAT ZINC CHROMATE PRIMER NSN 8010-00-899-8825 IMMEDIATELY FOLLOWING APPLICATION OF CHEMICAL FILM ALLOWING TIME FOR DRYING BETWEEN COATS.

Figure D-99.

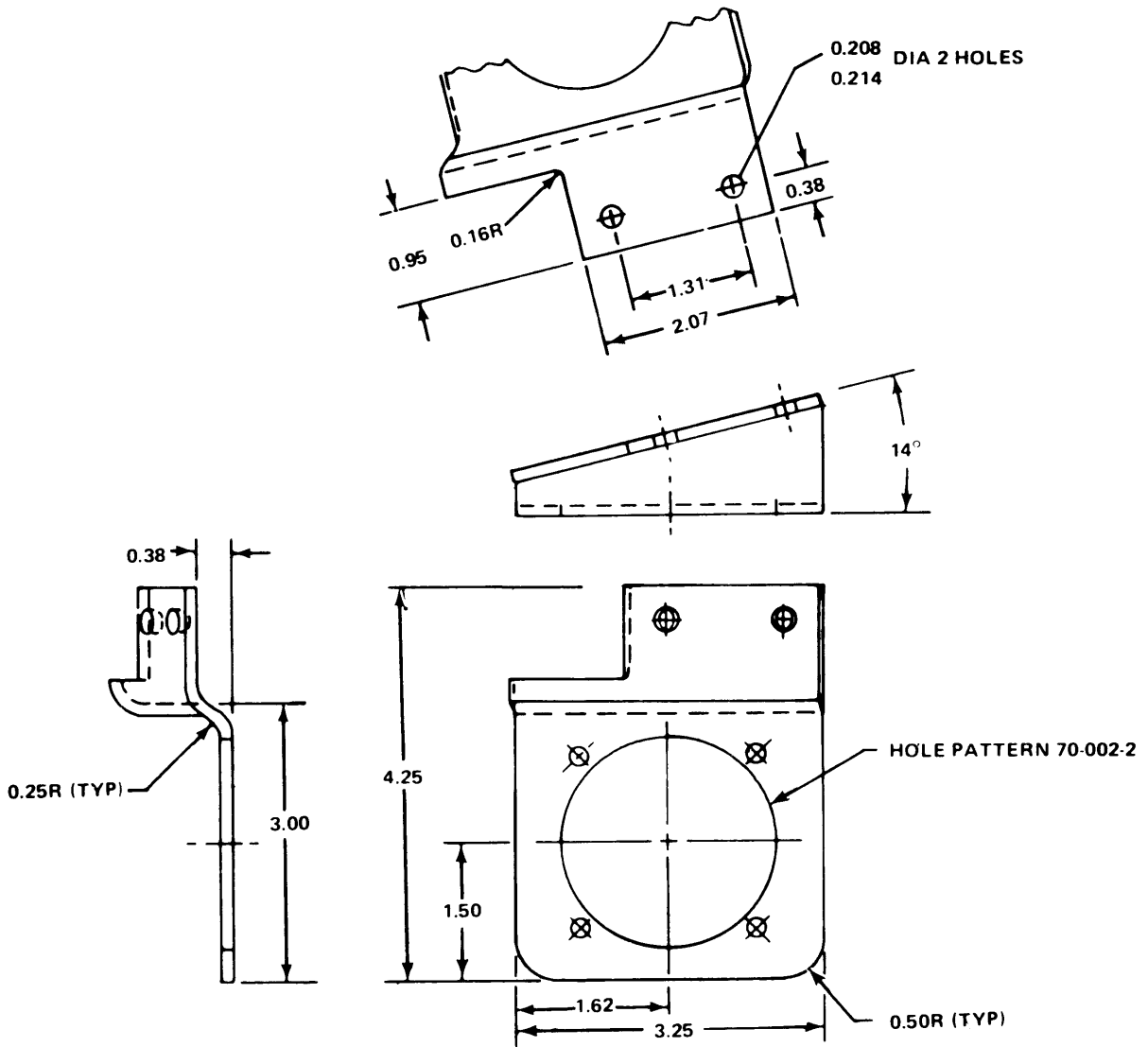
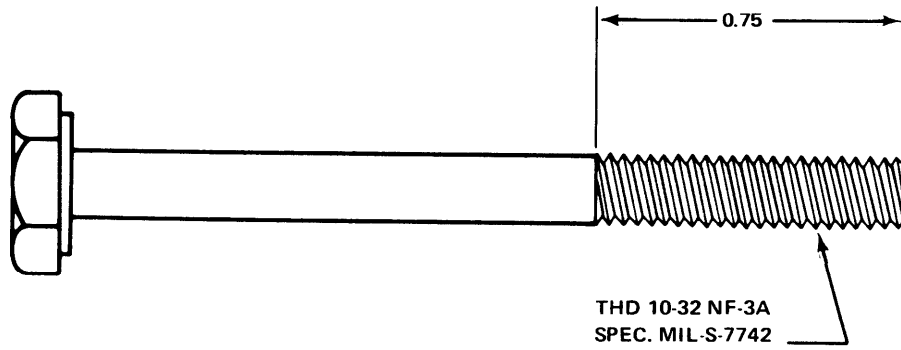


Figure D-100.

Part Number  
Fabricate from:  
Material:

204-072-054-1, BRACKET, Compass  
NSN 9535-00-232-0418  
2024 AL ALY Sheet, Federal Specification QQ-A-250/5, 0.125 Inch Thick



NOTE: MAKE FROM STD PART  
NO. AN3H20A

Figure D-101. Part Number 204-072-083-1 BOLT, Cargo Mirror  
Fabricate from: NSN 5306-00-182-2009  
Material:

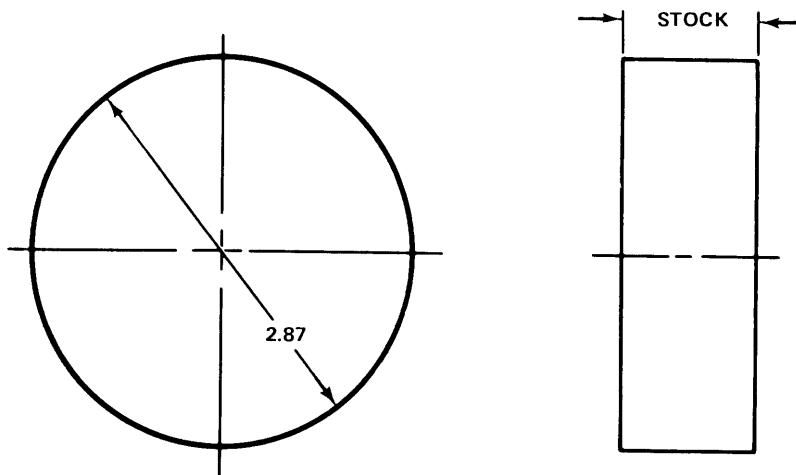
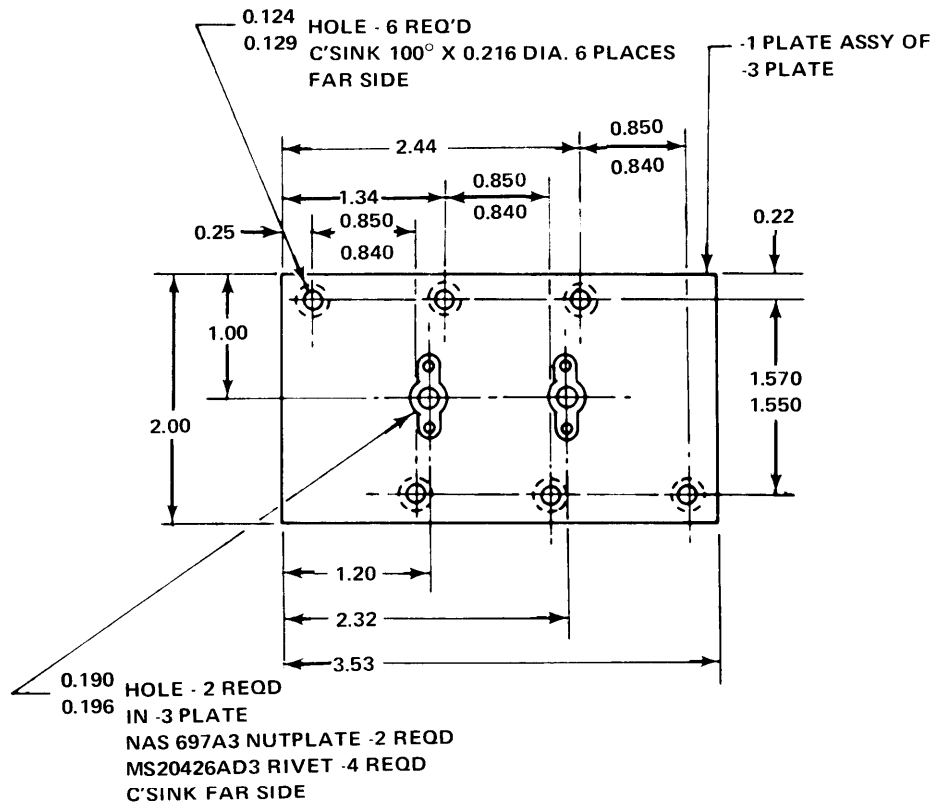


Figure D-102. Part Number 204-075-160-1 PAD, Battery Sump Jar  
Fabricate from: NSN 8305-00-191-1101  
Material: Felt Sheet, Grey Non-woven, Federal Specification C-F-2026  
Type 1, 0.50 Inch Thick, 1.0 Inch Wide



ZINC CHROMATE FINISH

**Figure D-103.** Part Number 204-075-520-1, PLATE, Assy Mounting  
 Fabricate from: NSN 9535-00-167-2280  
 Material: 2024 AL ALY Sheet, Federal Specification QQ-A-250/5, 0.040 Inch Thick



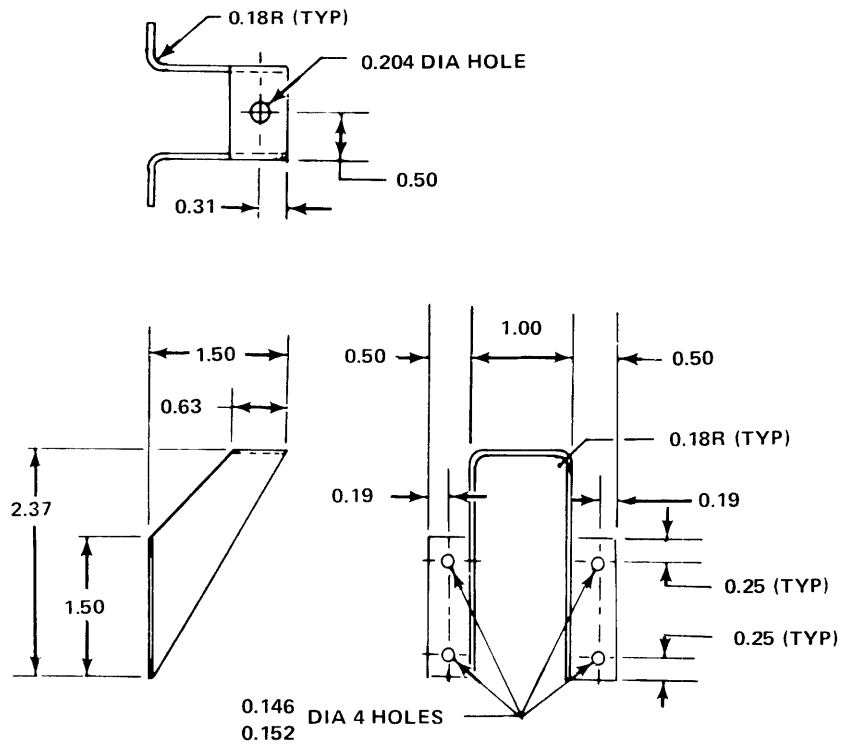
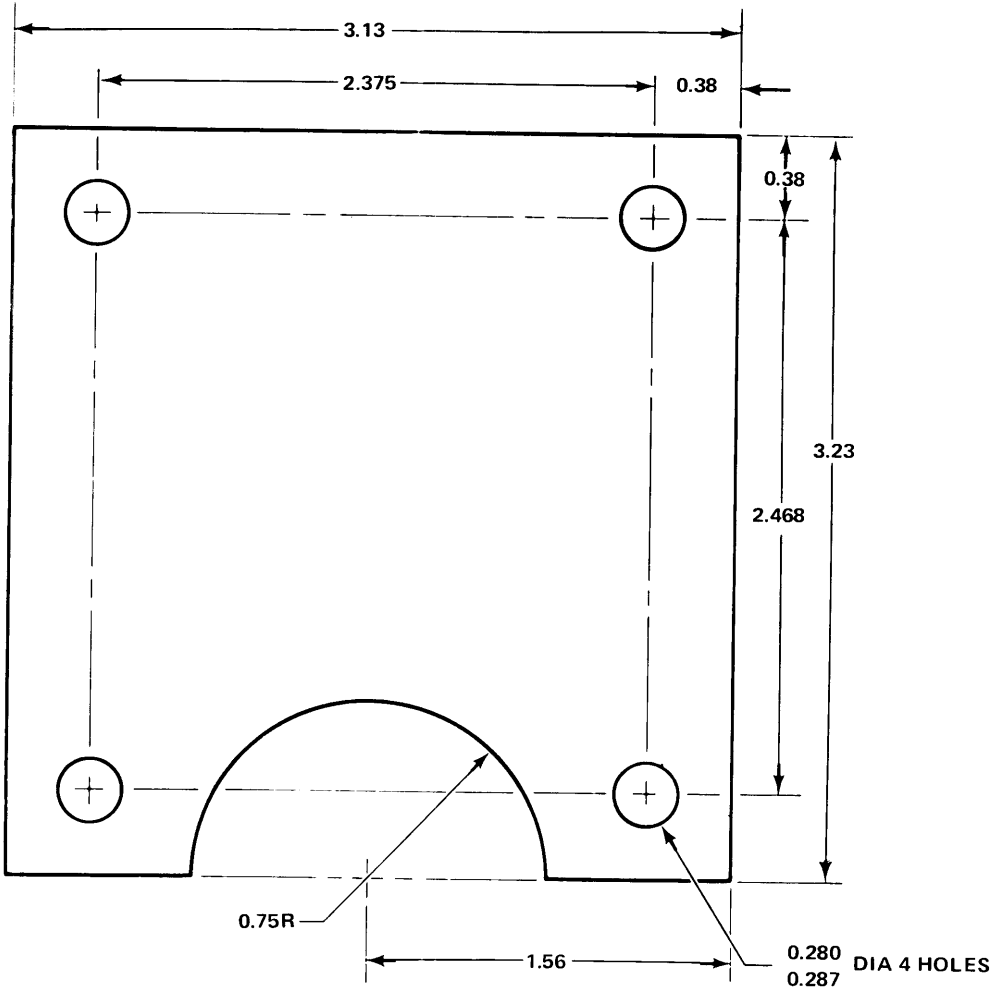


Figure D-104. Part Number 204-076-032-3 BRACKET  
 Fabricate from: NSN 9535-00-640-2311  
 Material: 2024 AL ALY Sheet, Federal Specification QQ-A-362,  
 0.050 Inch Thick



**Figure D-105.** Part Number 205-001-104-1, SHIM, Bellcrank Support Collective Controls  
Fabricate from: NSN 9535-00-167-2280  
Material: 2024 AL ALY Sheet, Federal Specification QQ-A-250/5, 0.040 Inch Thick

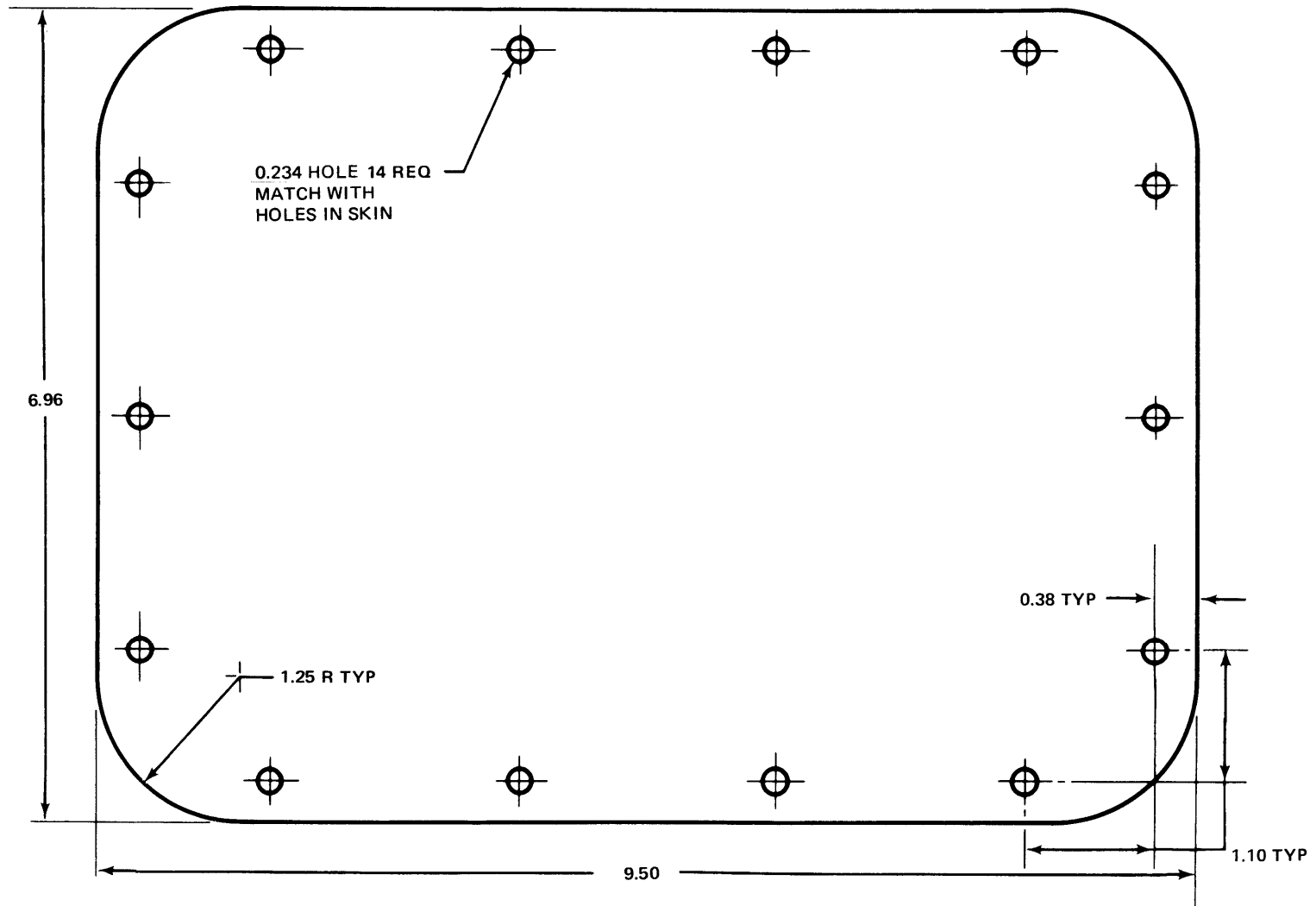
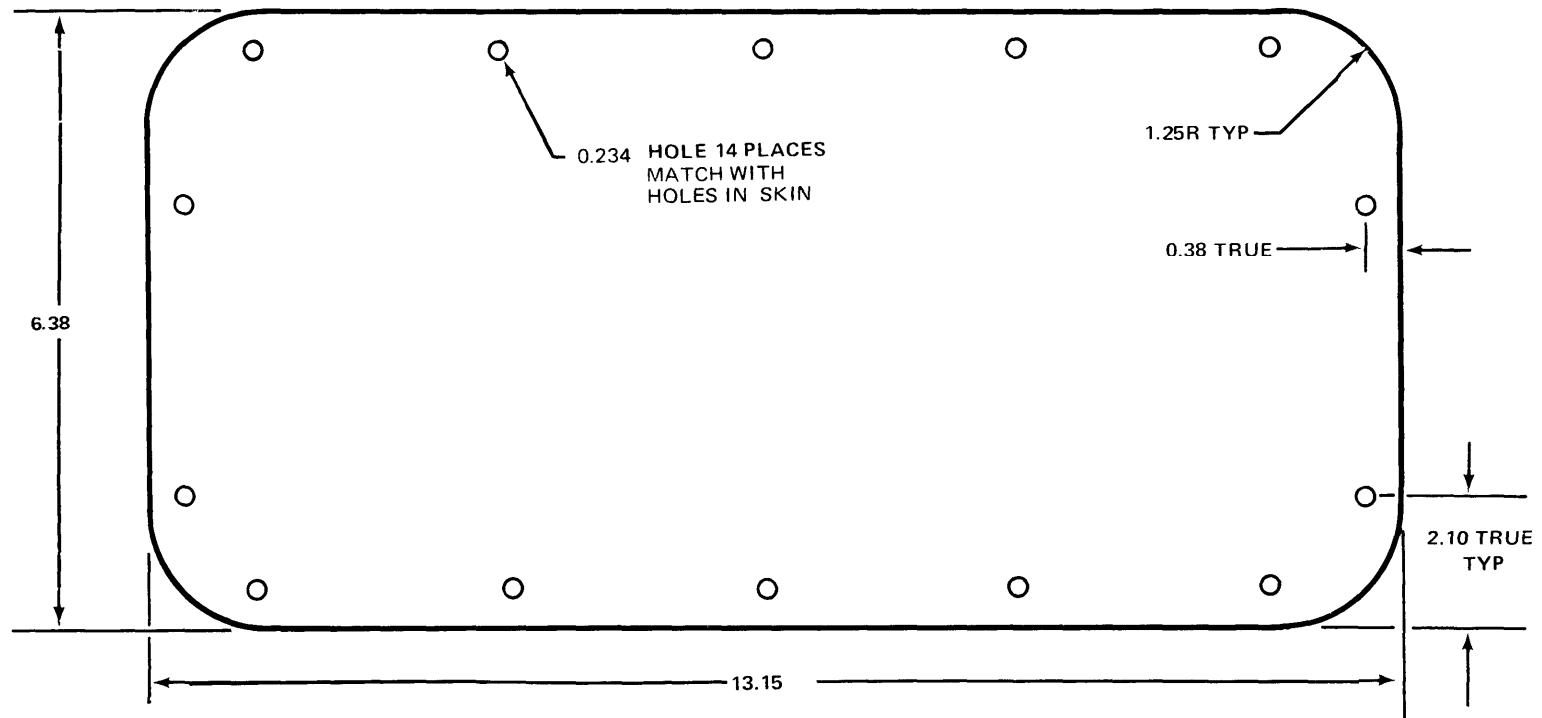
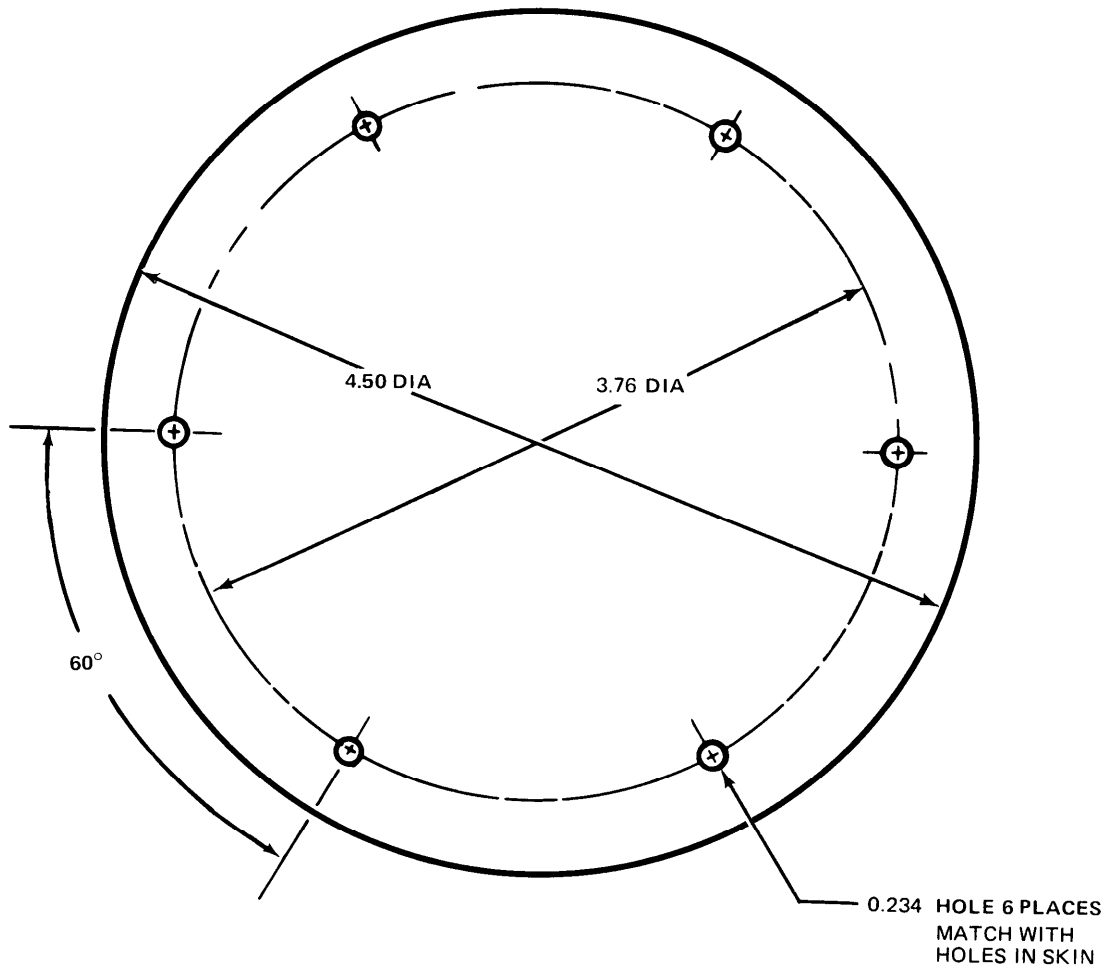


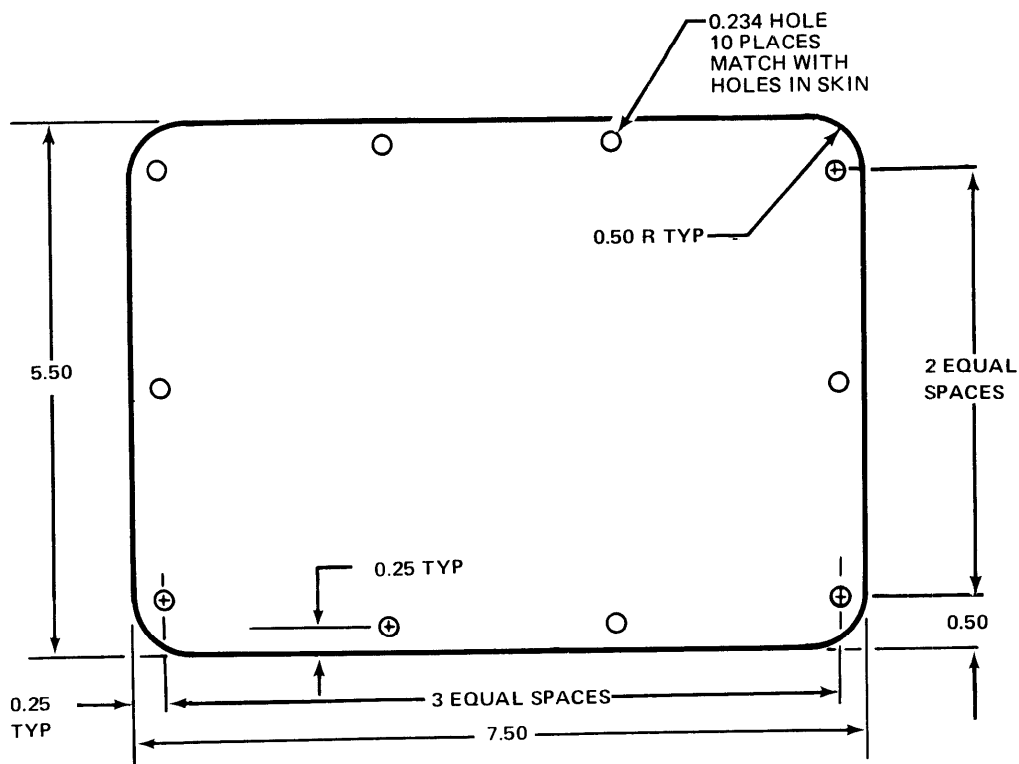
Figure D-106. Part Number 205-030-007-77 DOOR  
 Fabricate from: NSN 9535-00-167-2279  
 Material: 2024 AL ALY, Sheet, Federal Specification QQ-A-250/5 0.032 Inch Thick



**Figure D-107.** Part Number 205-030-007-97, DOOR, Left Hand (Shown)  
 205-030-007-98, DOOR, Right Hand, (Opp)  
 Fabricate from: NSN 9535-00-167-2279  
 Material: 2024 AL ALY Sheet, Federal Specification QQ-A-250/5, 0.032 Inch Thick



**Figure D-108.** Part Number 205-030-007-99, DOOR  
Fabricate from: NSN 9535-00-167-2278  
Material: 2024 AL ALY Sheet Federal Specification QQ-A-250/5, 0.025 Inch Thick



**Figure D-109**

Part Number	205-030-007-107, DOOR
Fabricate from:	NSN 9535-00-167-2279
Material:	2024 AL ALY Federal Specification QQ-A-250/5, 0.032 Inch Thick

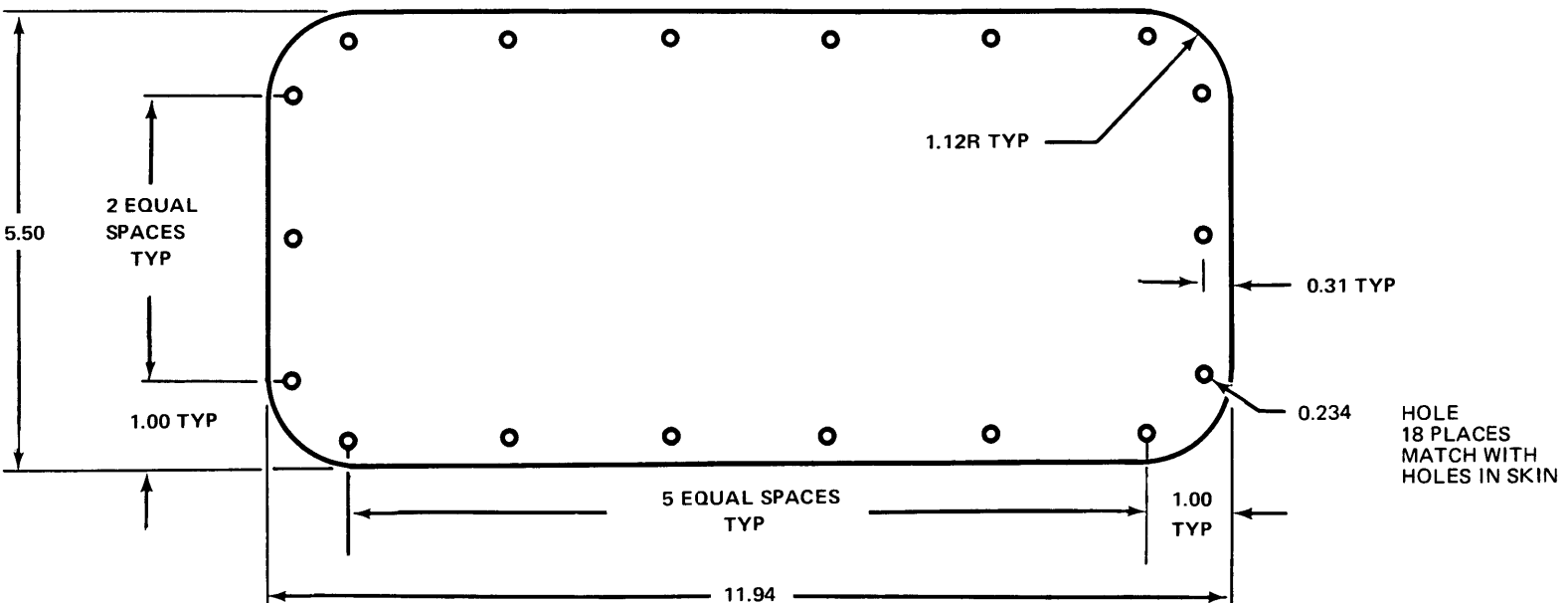


Figure D-110. Part Number 205-030-007-109, DOOR

Fabricate from: NSN 9535-00-167-2279

Material: 2024 AL ALY Sheet, Federal Specification QQ-A-250/5, 0.032 Inch Thick

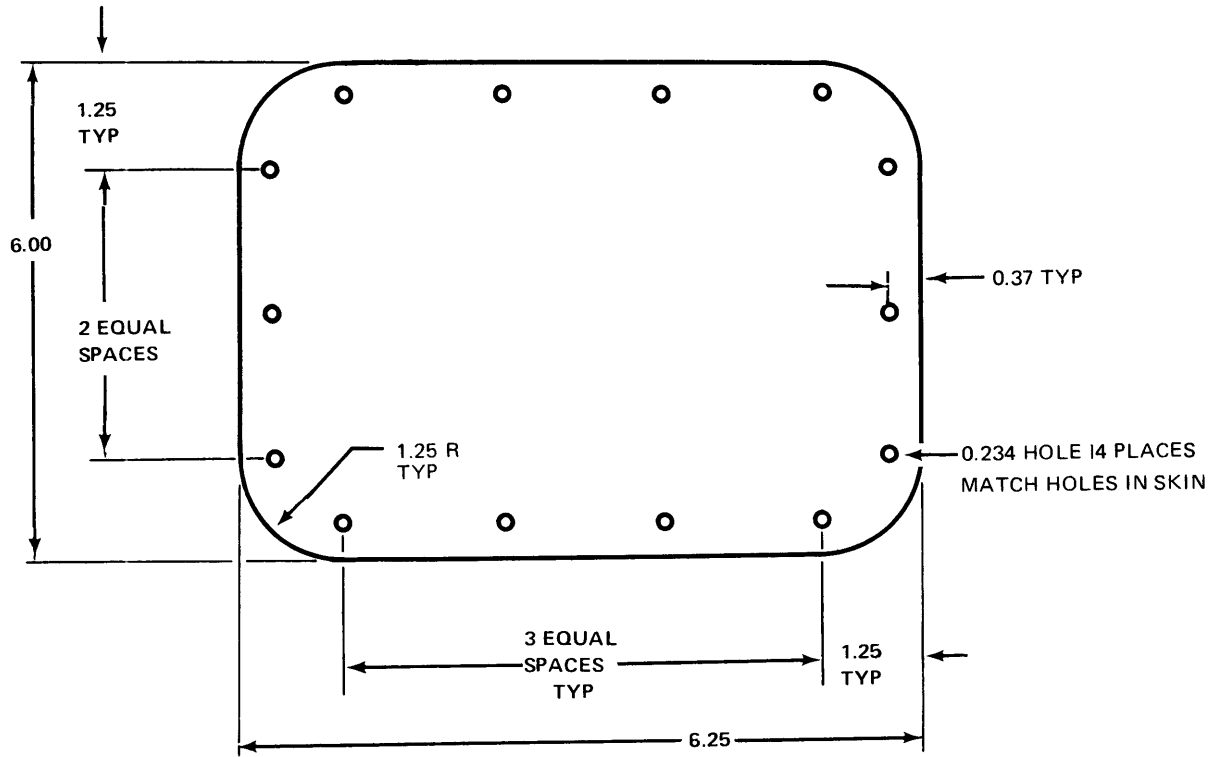
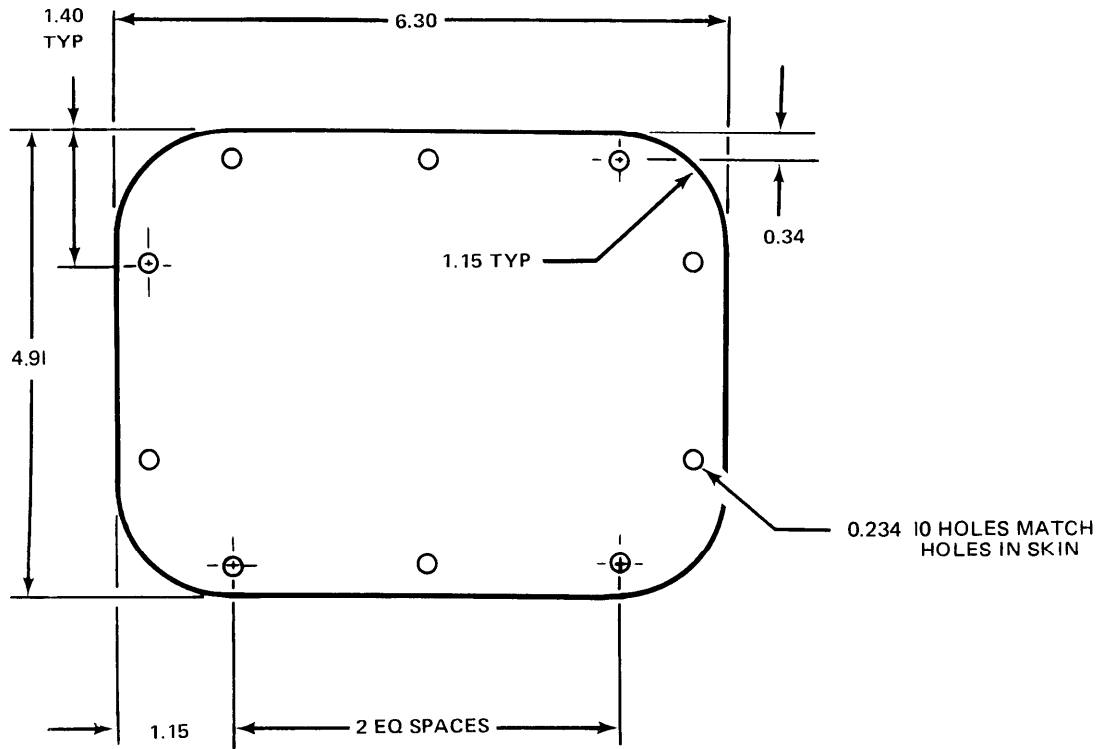
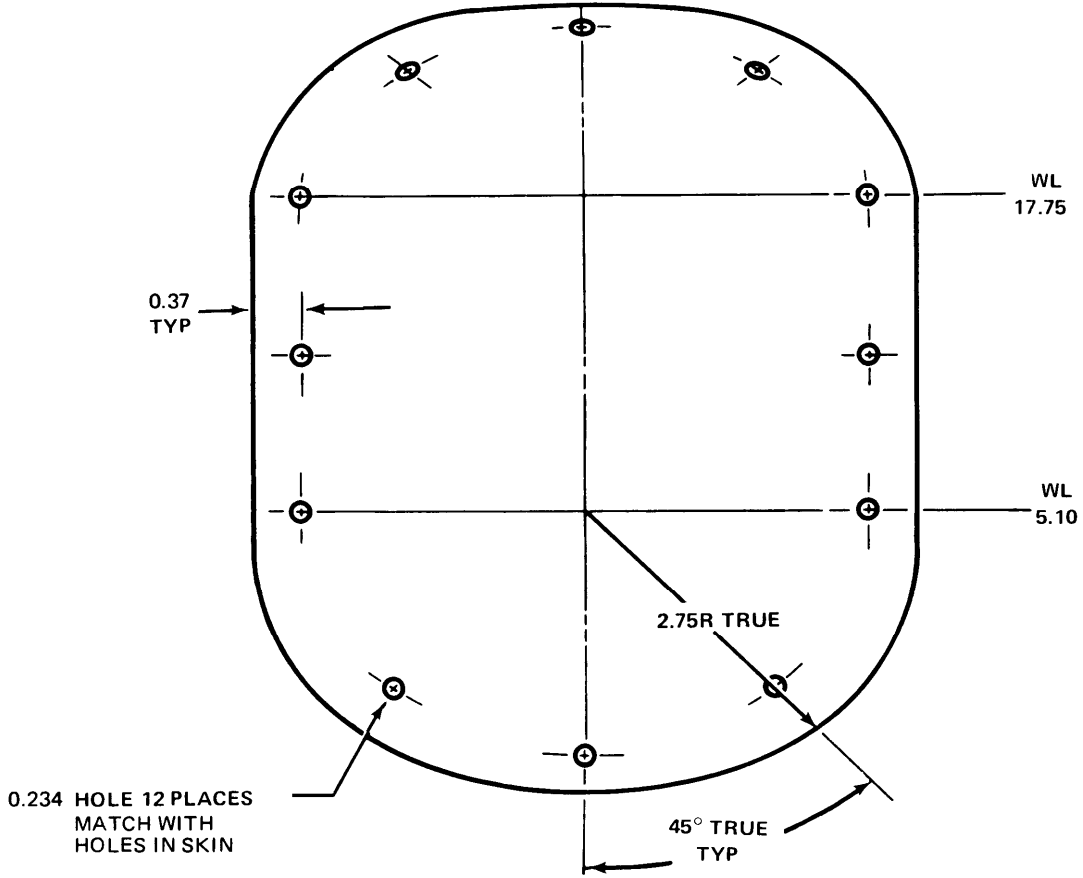


Figure D-111. Part Number 205-030-007-111 DOOR  
 Fabricate from: NSN 9535-00-167-2279  
 Material: 2024 AL ALY Sheet, Federal Specification  
 QQ-A-250/5, 0.032 Inch Thick

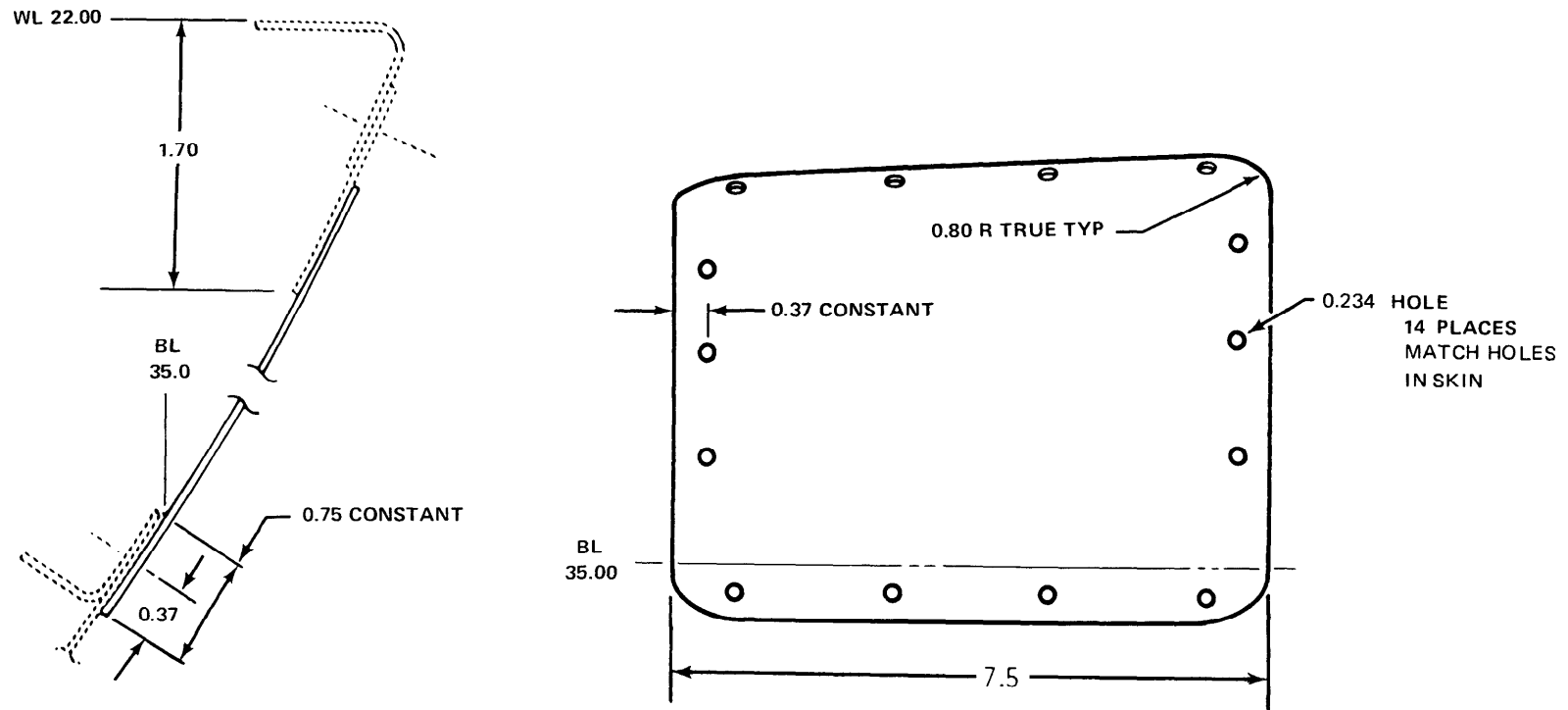




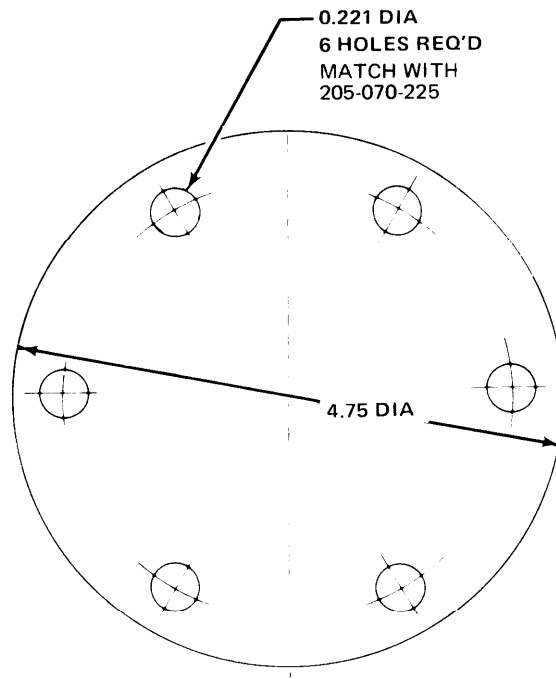
**Figure D-112.** Part Number 205-030-007-113, DOOR  
 Fabricate from: NSN 9535-00-167-2279  
 Material: 2024 AL ALY Sheet, Federal Specification QQ-A-250/5, 0.032 Inch Thick



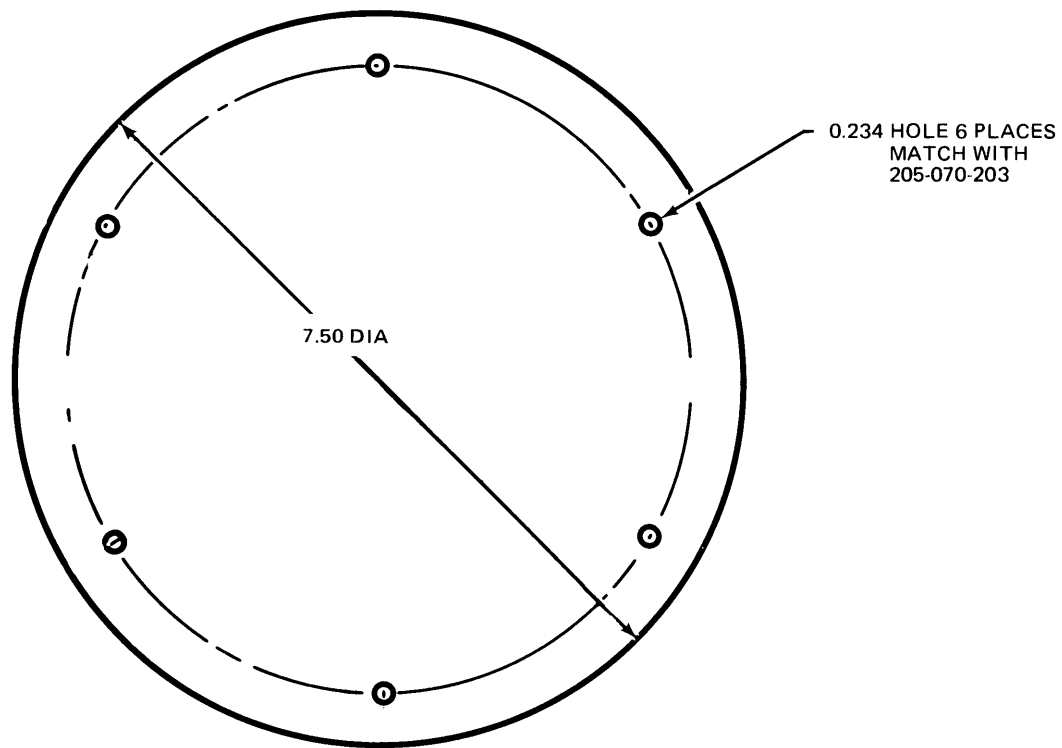
**Figure D-113.** Part Number 205-030-007-131, DOOR, Left Hand (Shown)  
DOOR, Right Hand (Opp)  
Fabricate from: NSN 9535-00-167-2278  
Material: 2024 AL ALY Sheet, Federal Specification QQ-A-250/5, 0.025 Inch Thick



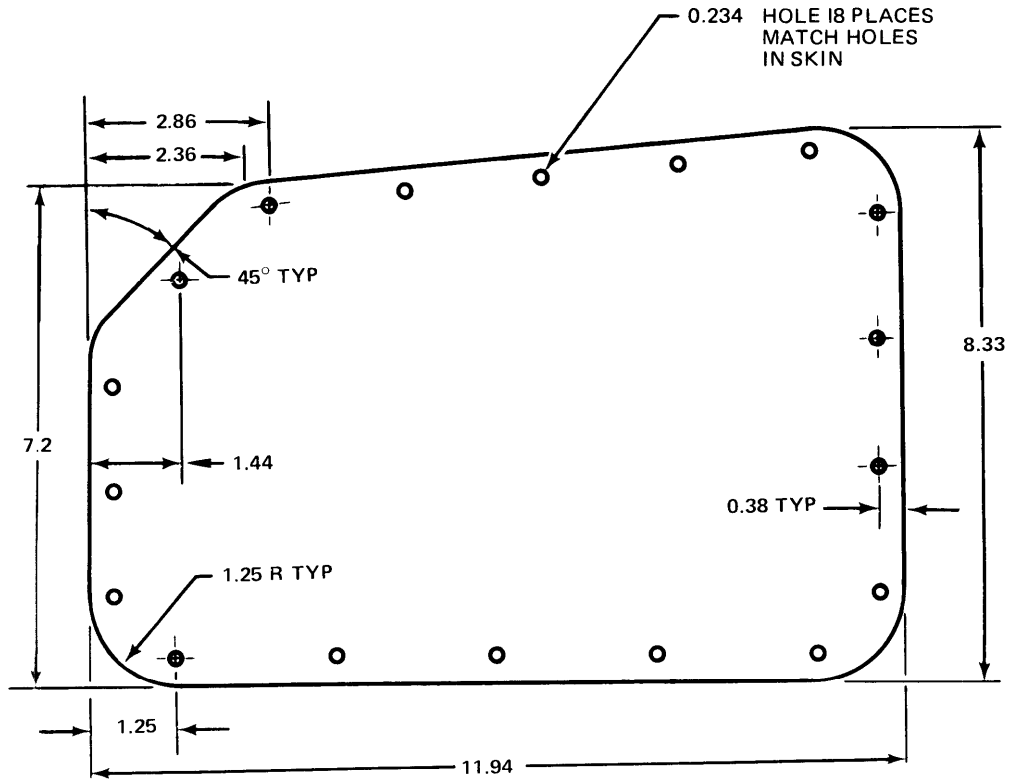
**Figure D-114.** Part Number 205-030-007-133 DOOR, Left Hand (Shown)  
 205-030-007-134 DOOR, Right Hand (Opp)  
 Fabricate from: NSN 9535-00-167-2278  
 Material: 2024 AL ALY Sheet, Federal Specification QQ-A-250/5, 0.025 Inch Thick



**Figure D-115.** Part Number 205-030-007-155 COVER  
Fabricate from: NSN 9535-00-167-2278  
Material: 2024 AL ALY Sheet, Federal Specification QQ-A-250/5, 0.025 Inch Thick



**Figure D-116.** Part Number 205-030-007-157, COVER  
Fabricate from: NSN 9535-00-167-2278  
Material: 2024 AL ALY Sheet, Federal Specification QQ-A-250/5, 0.025 Inch Thick



**Figure D-117.** Part Number 205-030-007-159, DOOR  
 Fabricate from: NSN 9535-00-167-2279  
 Material: 2024 AL ALY Sheet, Federal Specification QQ-A-250/5, 0.032 Inch Thick

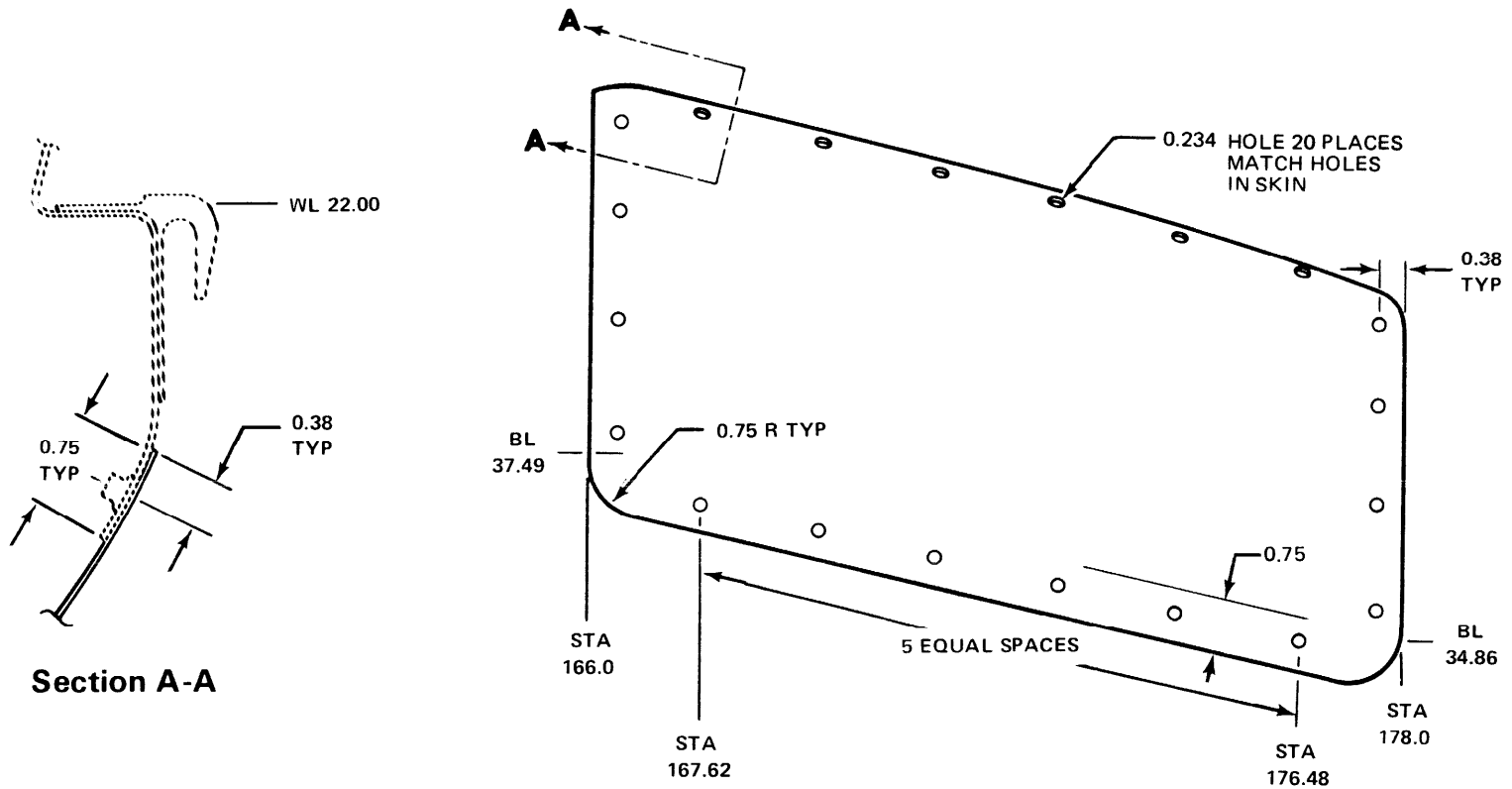


Figure D-118.

Part Number 205-030-007-179, DOOR, Left Hand Shown  
 205-030-007-180, DOOR, Right Hand Opp.  
 Fabricate from: NSN 9535-00-167-2278  
 Material: 2024 AL ALY Sheet, Federal Specification QQA-250/5, 0.025 Inch Thick

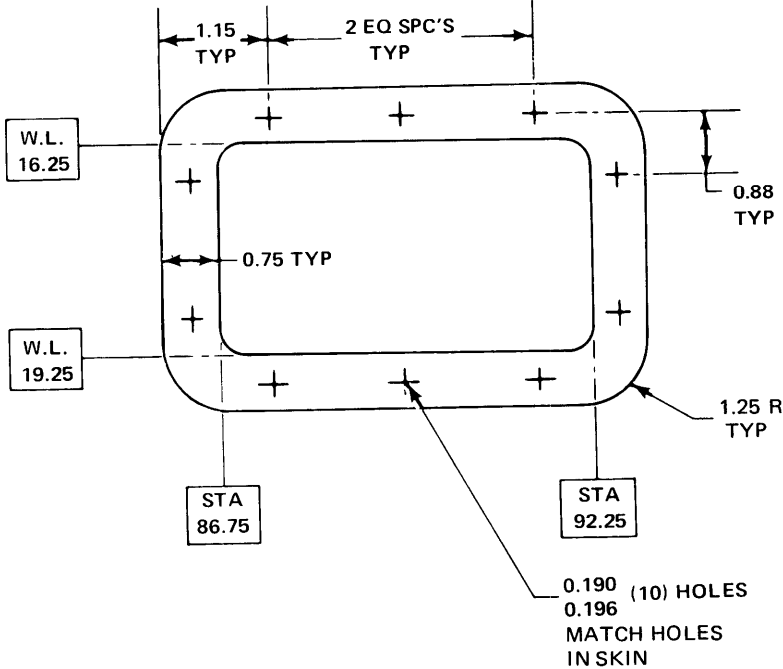
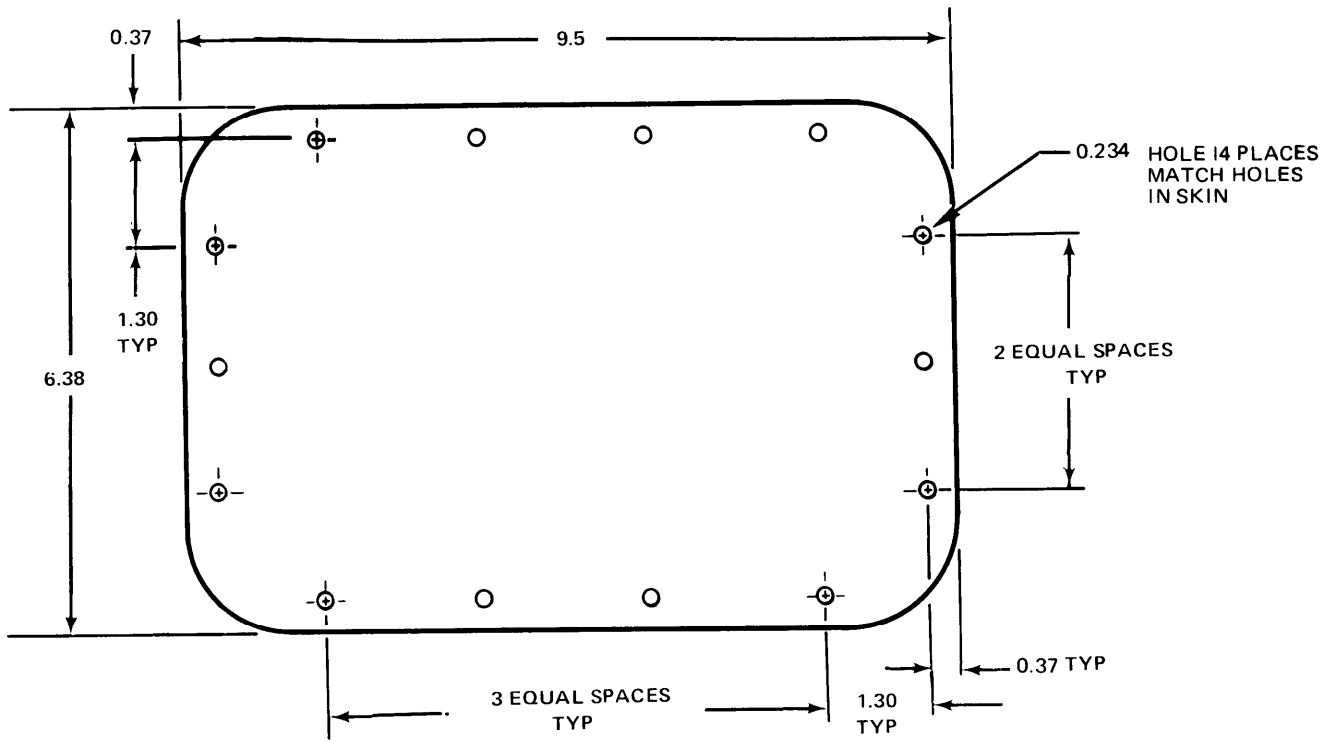


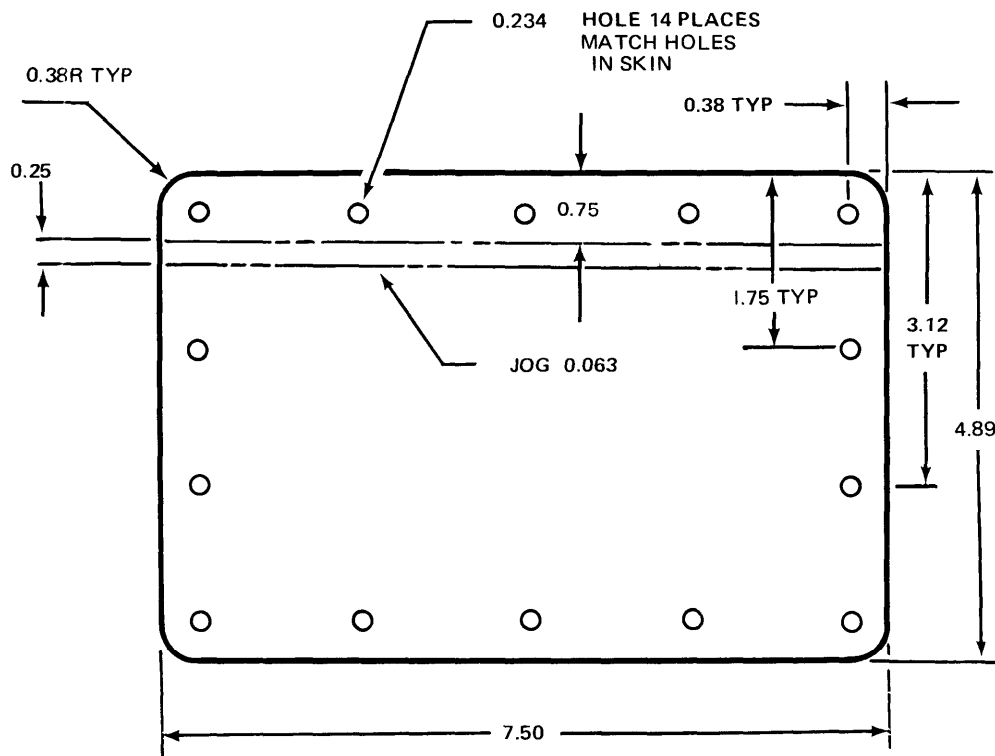
Figure D-119. Part Number  
Fabricate from:  
Material:

205-030-007-231 DOOR  
NSN 9535-00-167-2278  
2024 AL ALY Sheet, Federal Specification QQ-A-250/5,  
0.025 Inch Thick

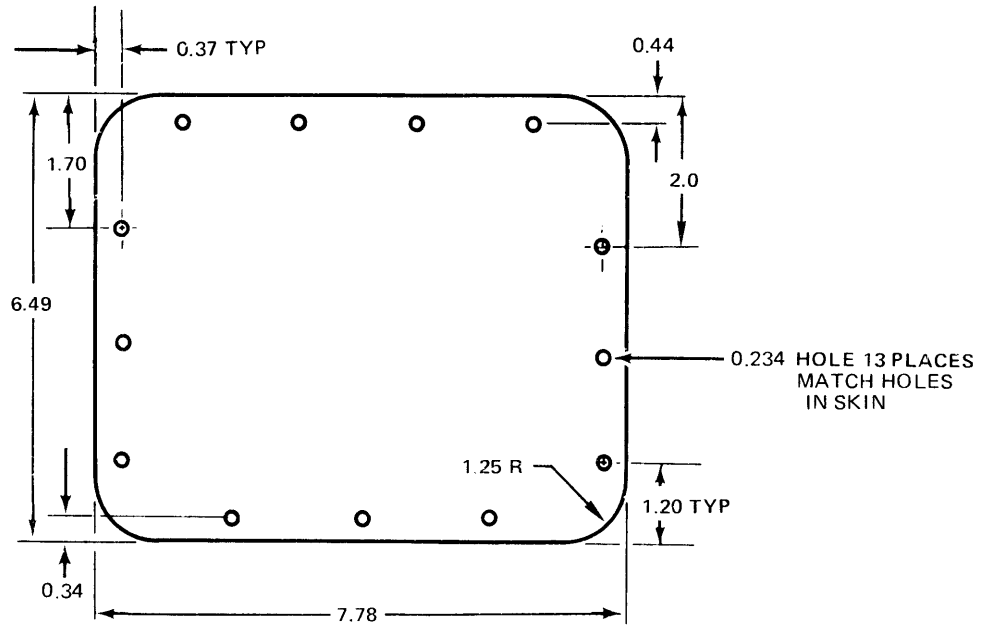




**Figure D-120.** Part Number 205-030-007-233, DOOR  
 Fabricate from: NSN 9535-00-167-2278  
 Material: 2024 AL ALY Sheet, Federal Specification, QQ-A-250/5, 0.025 Inch Thick



**Figure D-121.** Part Number 205-030-007-245, DOOR, Left Hand (Shown)  
 205-030-007-246, DOOR, Right Hand (OPP)  
 Fabricate from: NSN 9535-00-167-2279  
 Material: 2024 AL ALY Sheet, Federal Specification QQ-A-250/5, 0.032 Inch Thick



**Figure D-122.** Part Number 205-030-007-271, DOOR, Left Hand (Shn)  
 205-030-007-272, DOOR, Right Hand (Opp)  
 Fabricate from: NSN 9535-00-167-2279  
 Material: 2024 AL ALY Sheet, Federal Specification QQ-A-250/5, 0.032 Inch Thick

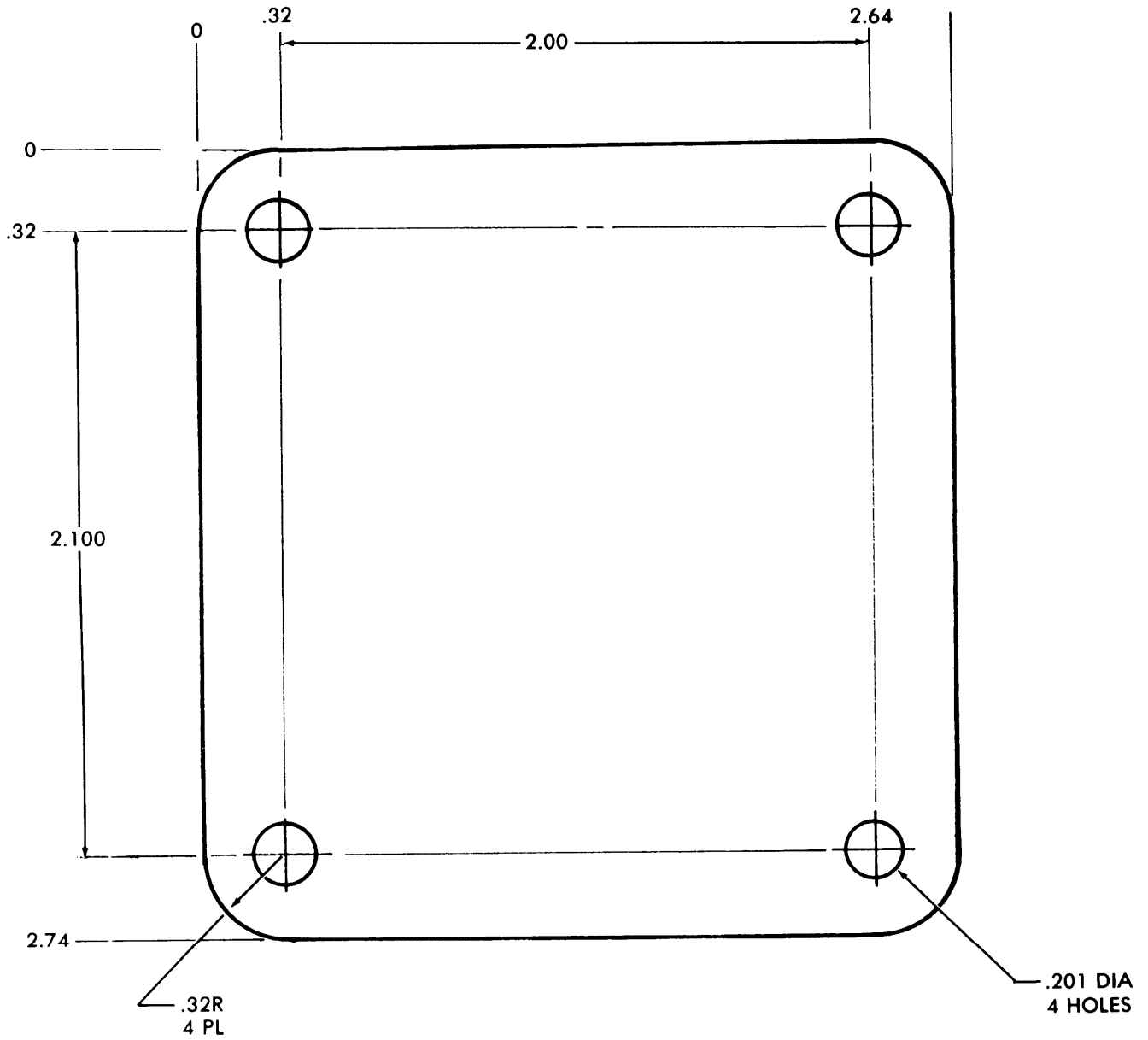
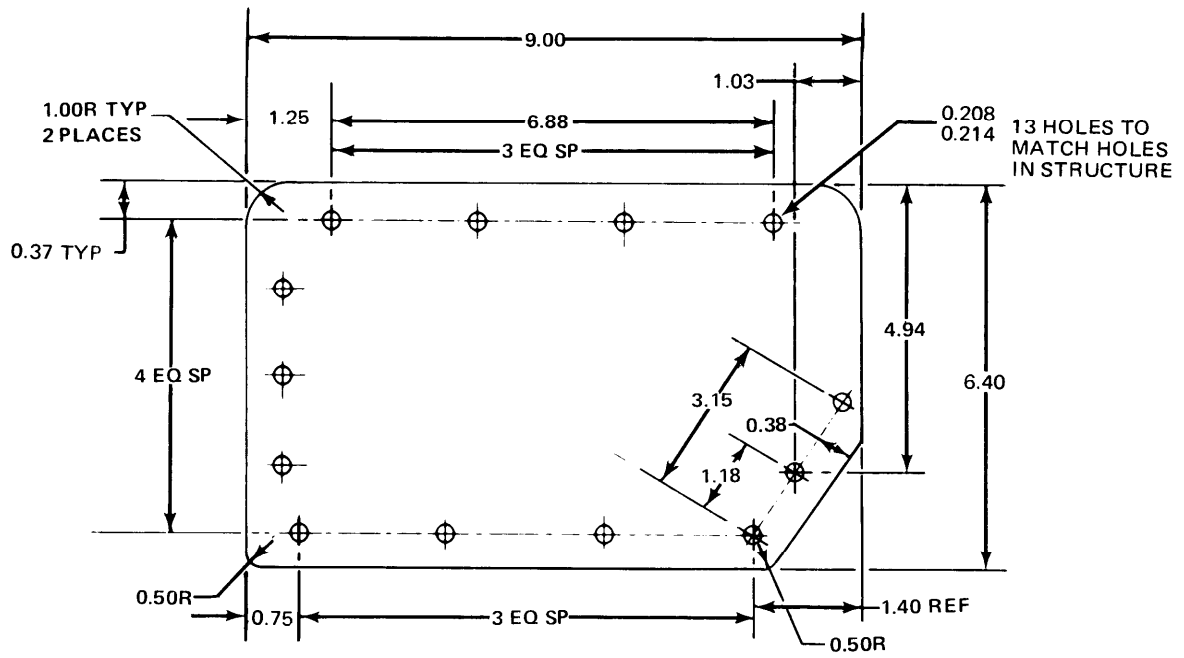
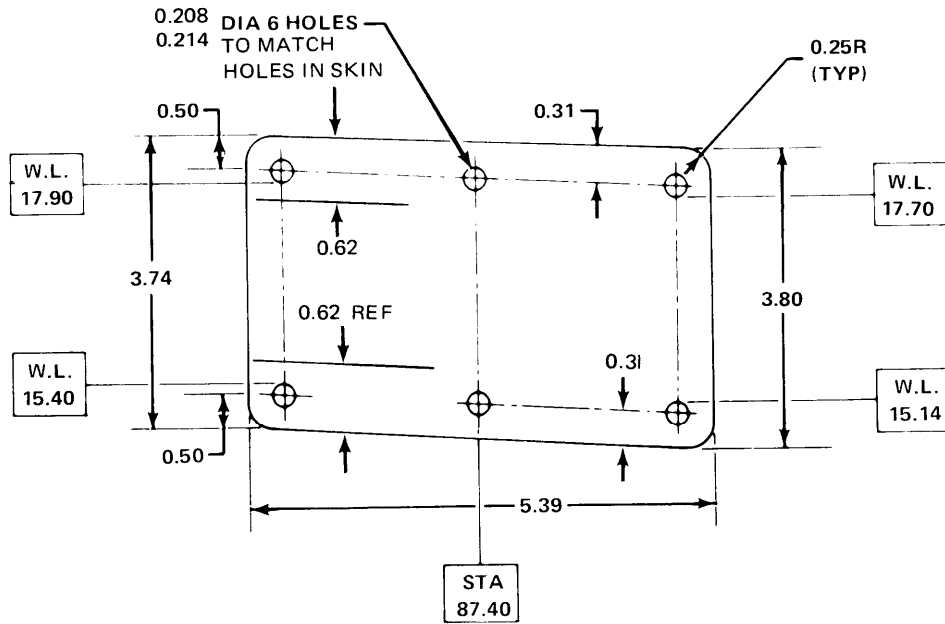


Figure D-123. Plate, Cover-Rearward PN 1951-1-3109  
 Fabricate from: NSN 9535-00-084-4448  
 Material: .063 THK AL ALY, SH6061-T6, QQ-A-250/11



**Figure D-124.** Part Number 205-030-007-341 DOOR  
 Fabricate from: NSN 9535-00-167-2279  
 Material: 2024 AL ALY Sheet, Federal Specification QQ-A-250/5, 0.032 Inch Thick



**Figure D-125.** Part Number 205-030-007-351 DOOR  
 Fabricate from: NSN 9535-00-167-2279  
 Material: 2024 AL ALY Sheet, Federal Specification QQ-A-250/5, 0.032 Inch Thick

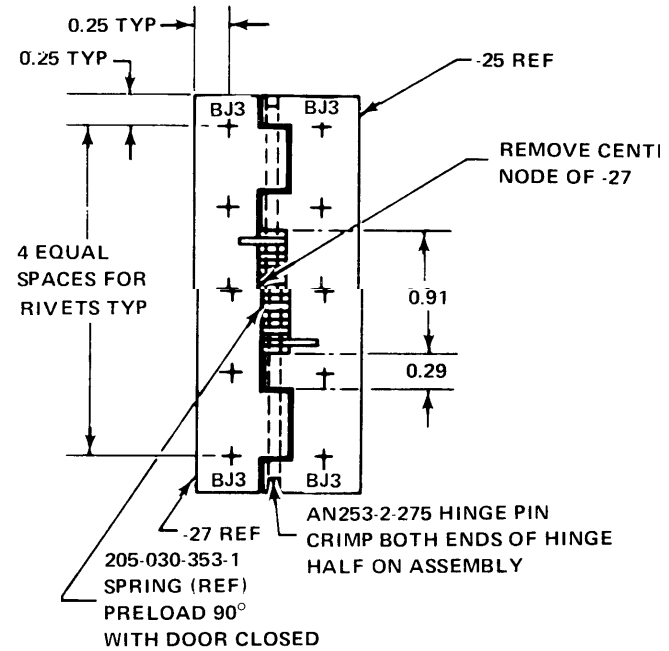
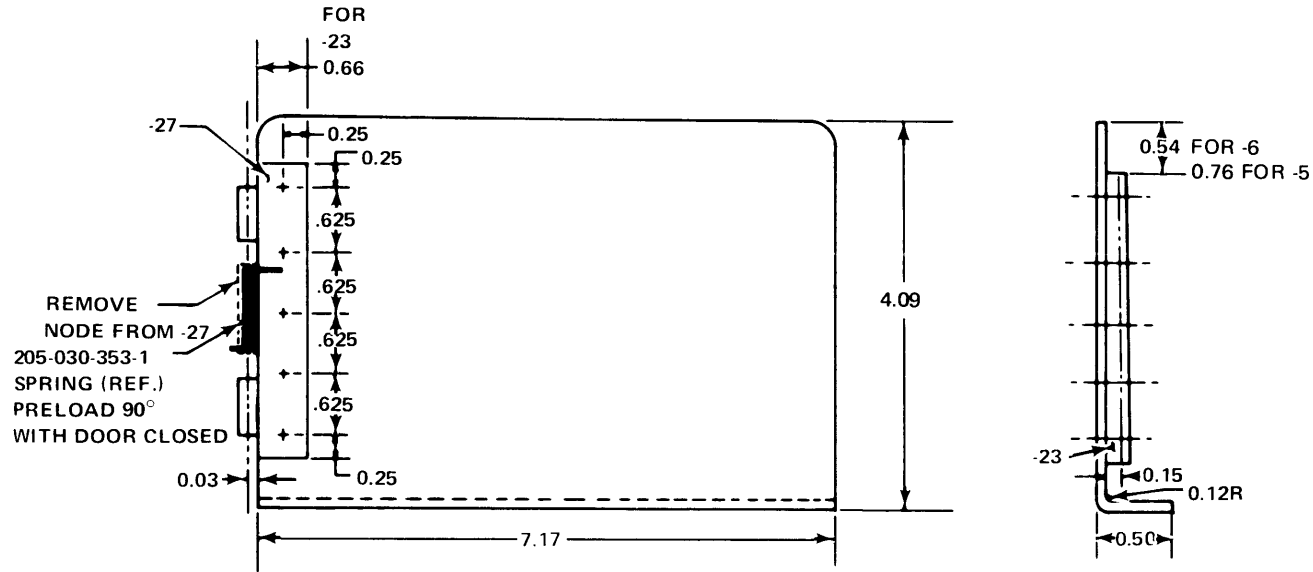


Figure D-126. Part Numbers 205-030-028-5 DOOR ASSEMBLY  
 205-030-028-6  
 206-030-028-25  
 205-030-028-27

Fabricate from: NSN 9535-00-167-2279  
 NSN 9330-00-576-3984  
 NSN 5340-00-661-8140

Material: 2024 AL ALY Sheet, Federal Specification QQ-A-250/5, 0.025 Inch Thick Hinge Butt, Aluminum Alloy Make From MS200001P3-7200 Material

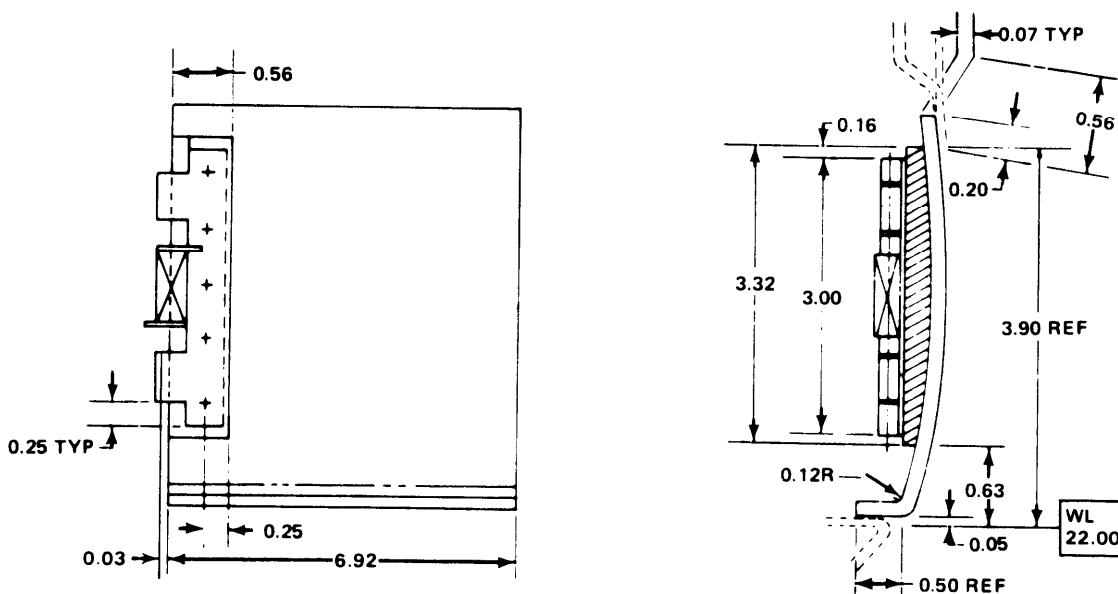


Figure D-127. Part Number: 205-030-031-7 DOOR ASSEMBLY  
 Fabricate from: NSN 9535-00-167-2279  
 NSN 9330-00-260-3806  
 NSN 5340-00-664-8140  
 Material: 2024 AL ALY Sheet, Federal Specification QQ-A-250/5, 0.032 Inch Thick  
 Plastic Sheet Phenolic, Federal Specification MIL-D-1503S, 0.250 Inch Thick

205030-2002

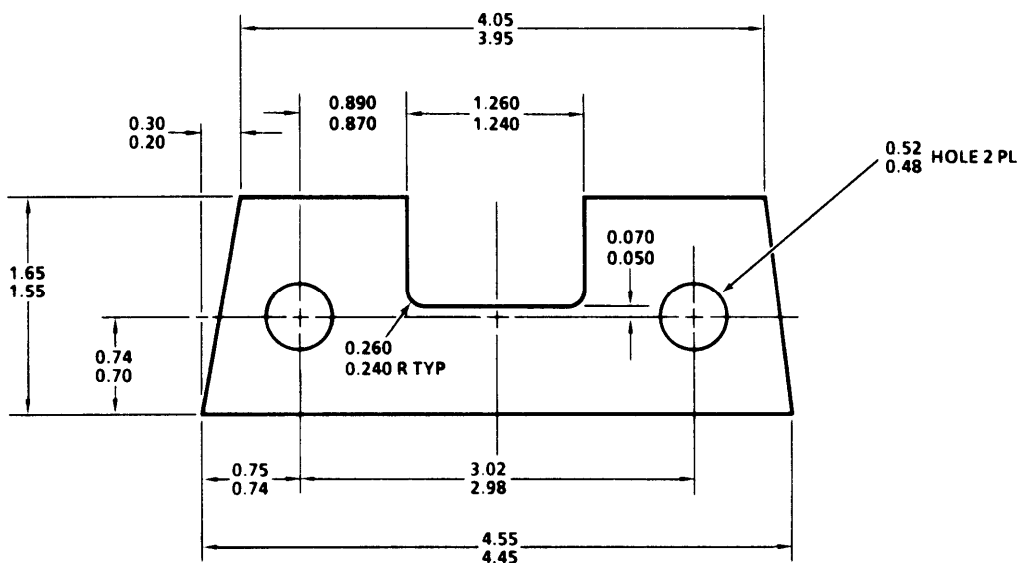
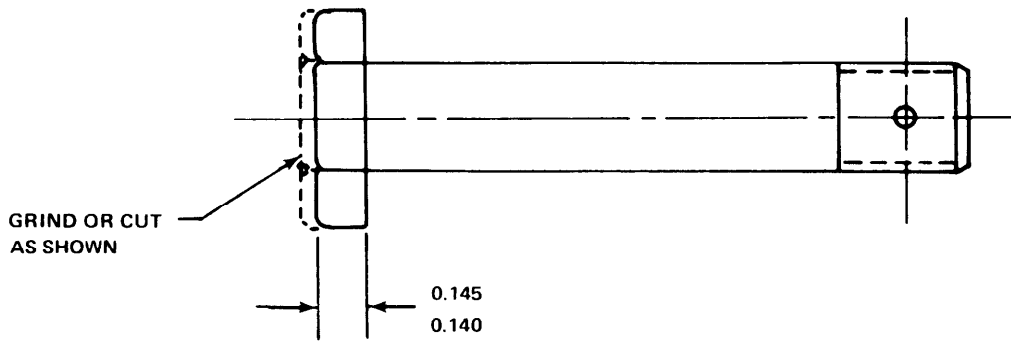


Figure D-127.1. Part Number: 204-011-213-101, Hub Spring Main Rotor Shim

Fabricate From:  
 Material: Cres shim, MIL-S-22499 Comp 3  
 TY1, CL2  
 Thickness 0.0900  
 Width 2.000  
 Length 5.0

204011-2053  
 204-011-213-101





NOTES:  
1. MACHINED AREA TO BE BRUSH CAD PLATED.

Figure D-128. Part Number 204-011-461-1 BOLT, SWASHPLATE  
Fabricate from: NSN 5306-00-639-2277  
Material: Bolt Shear Steel, Make from NAS 464-5-20

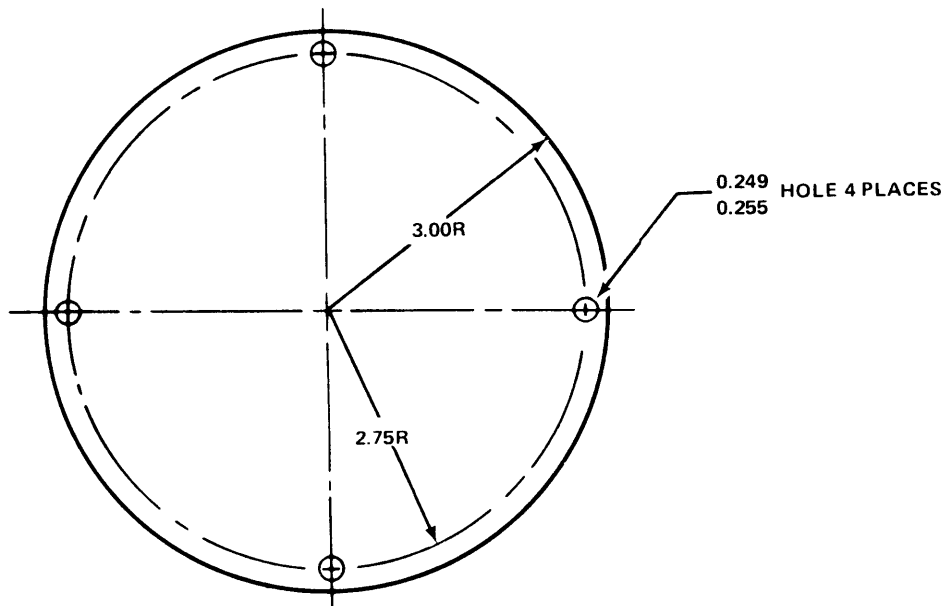
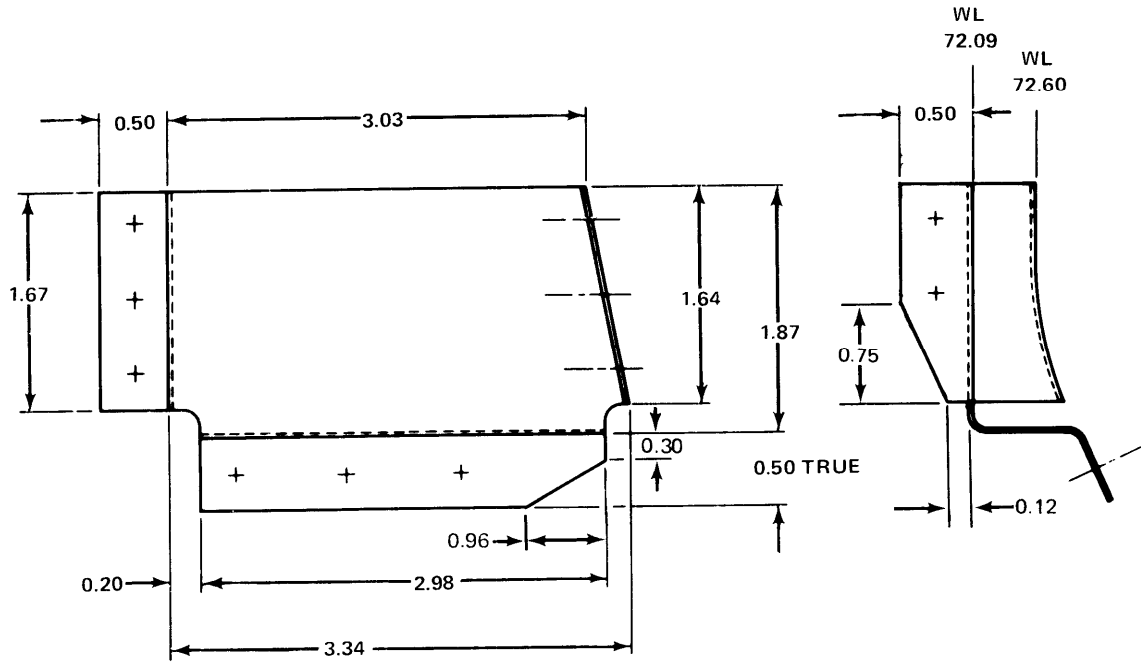
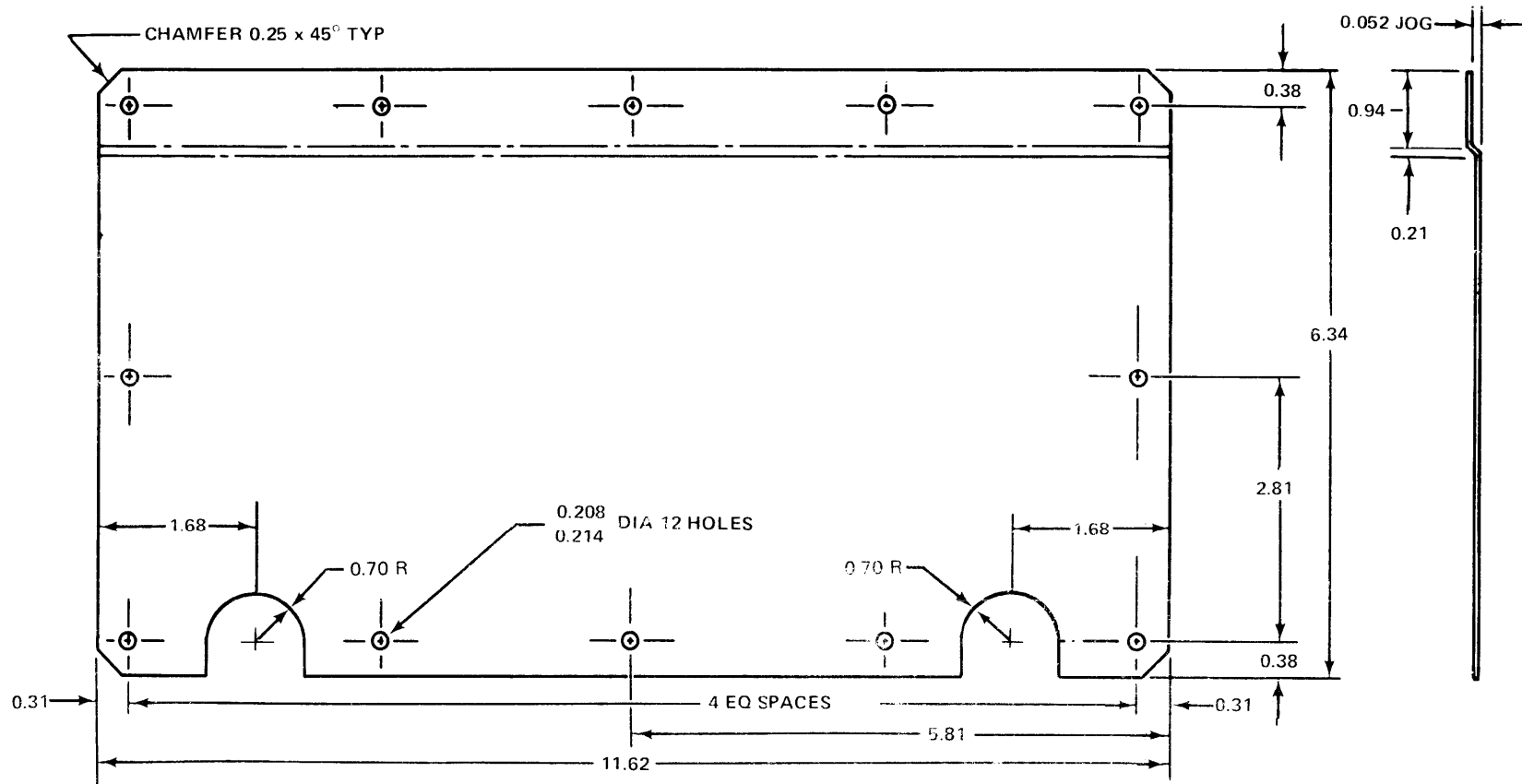


Figure D-129. Part Number 205-030-247-25 COVER PLATE  
Fabricate from: NSN 9533-00-167-2278  
Material: 2024 AL ALY Sheet, Federal Specification QQ-A-250/5, 0.025 Inch Thick

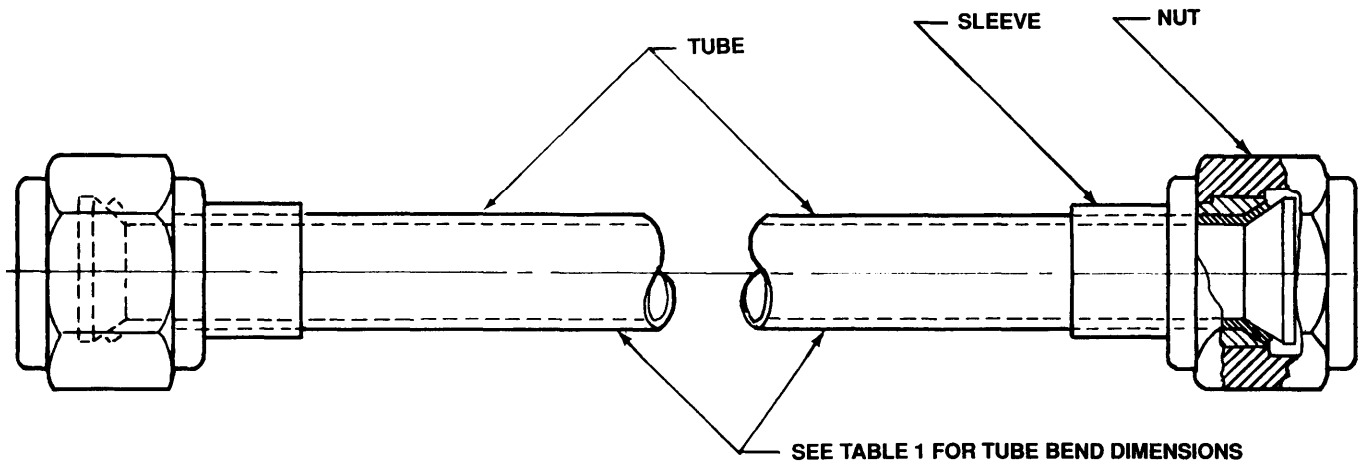


**Figure D-130.** Part Number 205-030-302-5 & -6, SUPPORT, Stop Cargo Door  
 Fabricate from: NSN 9535-00-167-2280  
 Material: 2024 AL ALY Sheet, Federal Specification QQ-A-25/5, 0.040 Inch Thick

TM 55-1520-210-23-3



**Figure D-131.** Part Number 205-030-309-13, COVER  
Fabricate from: NSN 9535-00-167-2279  
Material: 2024 AL ALY Sheet, Federal Specification QQ-A-250/5, 0.032 Inch Thick



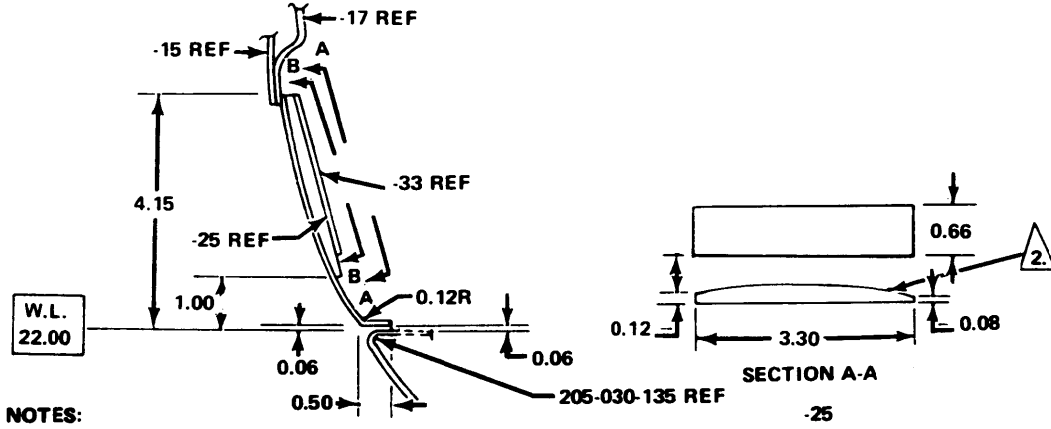
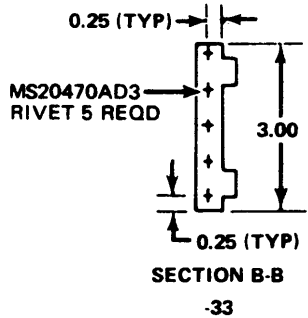
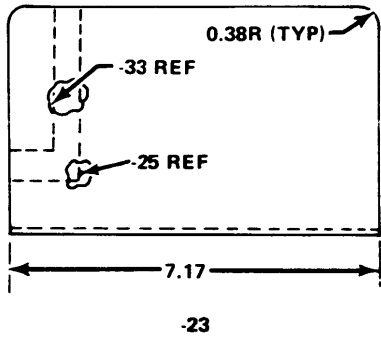
**TUBE ASSEMBLY**  
Fabricate from:

Figure D-132. Part Number	Tube NSN	Nut NSN	Sleeve NSN
205-030-431-1	4710-00-279-0955	4730-00-142-2167	4730-00-278-6070
205-030-432-1	4710-00-279-0955	4730-00-142-2167	4730-00-276-6070
205-040-130-1	4710-00-279-0955	4730-00-142-2167	4730-00-276-6070

**TABLE 1**

	BEND NO.	DISTANCE FROM THE END	RADIUS INCHES	DEGREE OF BEND	DIAL ROTATION CLOCKWISE REQ.
205-030-431-1	1ST	9	15/16	55°	0°
	2ND	14 3/8	15/16	55°	182°
	3RD	23 1/4	15/16	42°	328°
	4TH	31 3/4	15/16	42°	178°
	5TH	40 1/4	15/16	28°	276°
	6TH	42 1/4	15/16	28°	180°
205-030-432-1	1ST	1 7/8	15/16	57°	0°
	2ND	7 5/8	15/16	57°	180°
	3RD	31 1/8	15/16	70°	150°
	4TH	34	15/16	78°	0°
205-040-130-1	1ST	1.63	.93	83°	0°
	2ND	5.81	.93	76°	170°
	3RD	11.93	.93	84°	340°
	4TH	20.43	.93	73°	180°
	5TH	31.43	.93	40°	225°
	6TH	33.75	.93	77°	100°

205-030-431-1      **MINIMUM STOCK LENGTH 50.0 INCHES**  
 205-030-432-1      **MINIMUM STOCK LENGTH 44.5 INCHES**  
 205-040-130-1      **MINIMUM STOCK LENGTH 39.0 INCHES**



NOTES:

1. APPLY ONE COAT ZINC CHROMATE PRIMER NSN 8010-00-899-8825 PER TB 746-83-2 FOLLOWING APPLICATION OF CHEMICAL FILM.
- △ 2. CONTOUR TO MATCH -23 DOOR.

1	-33	HINGE HALF	1
1	-25	SPACER	2
1	-23	DOOR	1
QTY REQ'D		NOMENCLATURE OR DESCRIPTION	NOTES

Figure D-133. Part Number  
Fabricate from:

Material:

205-030-029-5 DOOR ASSEMBLY

NSN 9535-00-167-2174

NSN 5340-00-664-8140

NSN 9330-00-260-3807

2024 AL ALY Sheet, Federal Specification QQ-A-250/4,  
Temp T3, 0.025 Inch Thick

Hinge, Butt Aluminum Alloy, Make from Material MS20257-X93-400

Plastic Sheet Phenolic, Federal Specification MIL-P-15035,

0.1875 Inch Thick

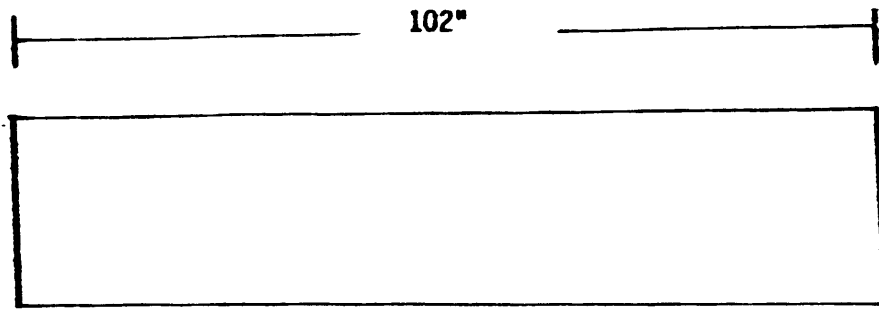
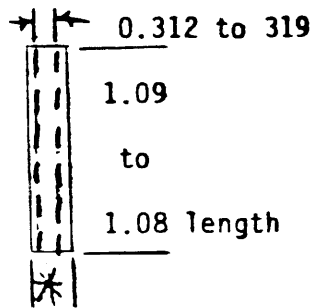


Figure D-134      Part Number:      110-119-1  
 Fabricate from:      NSN 9390-00-622-4420  
 Material:      Extrusion—Rubber

Figure D-135  
 Part Number: UH-1 S0054-1  
 Fabricate from: NSN 9510-00-056-1916  
 Material: Metal bar steel, QQ-S-763, class 310  
 Hot Rolled Annealed, 0.5 inch diameter



Grind O.D to provide an interference fit of 0.0001 to 0.0003 to fill existing reamed out hole with maximum diameter of 0.3594 plus 0.000 minus 0.001.

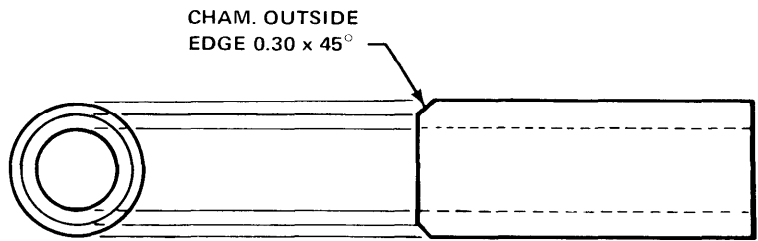


Figure D-136. Part Number 205-030-543-17 SPACER  
Fabricate from: NSN 5340-00-809-9379  
Material: Spacer, Sleeve, Aluminum Alloy, Make from NAS 43DD3-51 Spacer

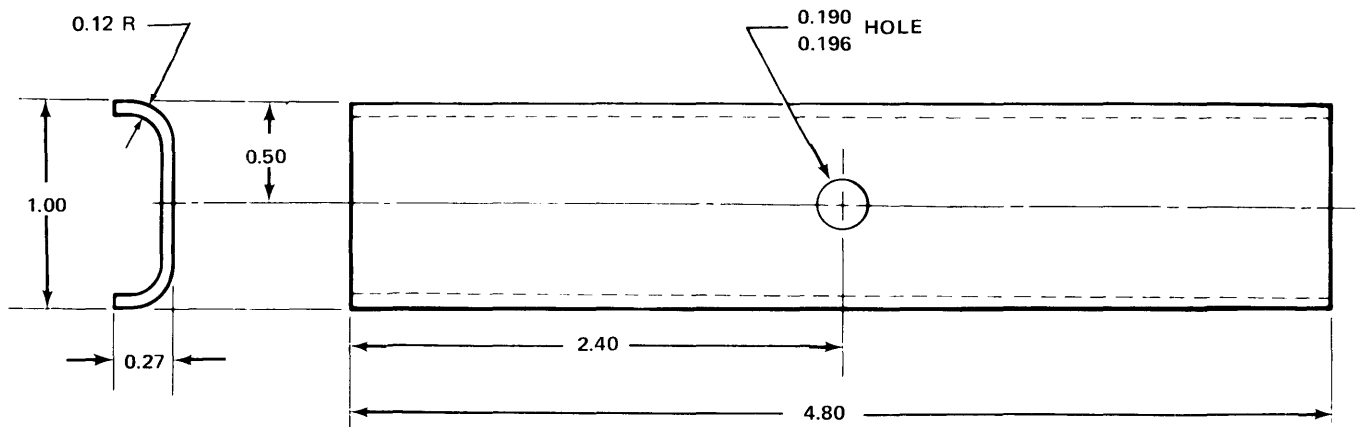
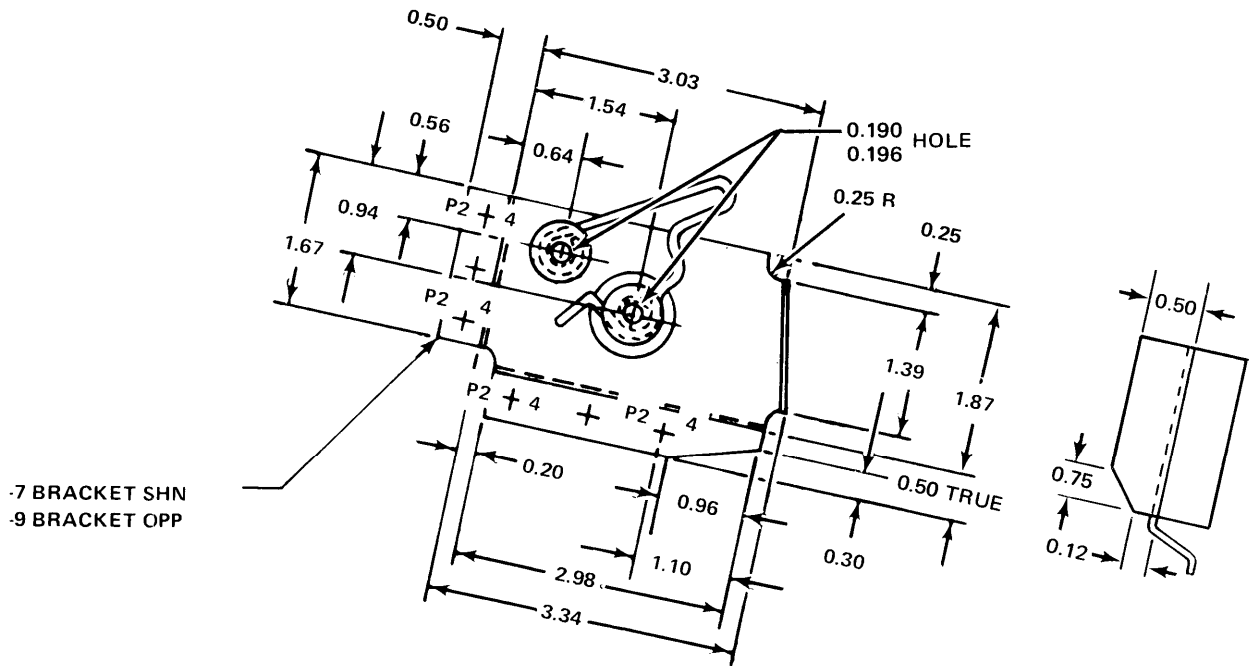


Figure D-137. Part Number 205-030-614-13 CHANNEL  
Fabricate from: NSN 9535-00-167-2279  
Material: 2024 AL ALY Sheet, Federal Specification QQ-A-250/5, TEMP T3, 0.032 Inch Thick



NOTES:

1. ALL BEND RADII 0.09
2. ALL BEND RELIEF 0.16R

Figure D-138. Part Number

205-030-671-7 BRACKET

205-030-671-9

Fabricate from:

NSN 9535-00-167-2280

Material:

2024 AL ALY Sheet, Federal Specification QQ-A-250/5,  
TEMP O H.T. T42, 0.040 Inch Thick



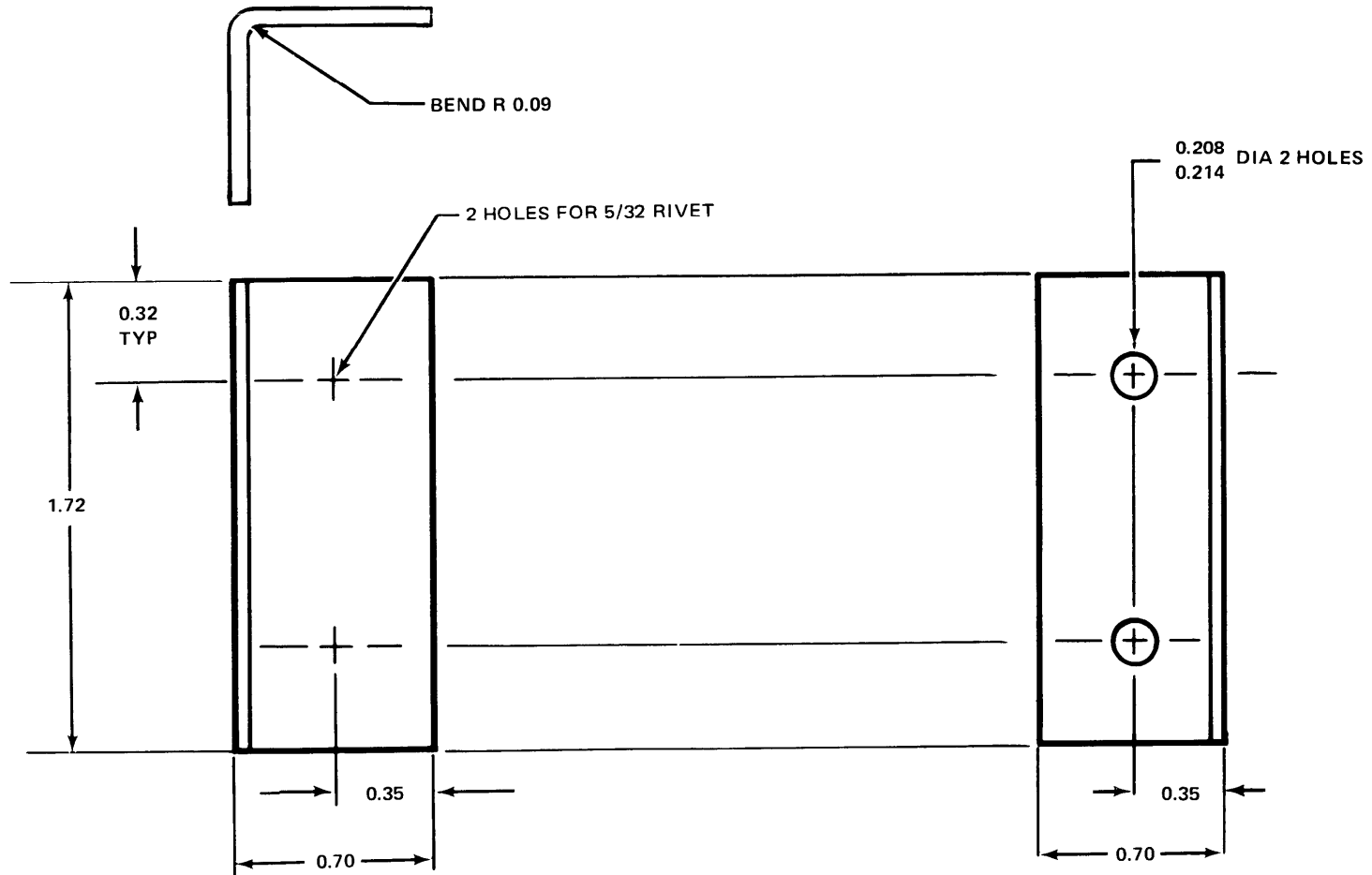


Figure D-139. Part Number  
 Fabricate from:  
 Material:

205-030-737-3 BRACKET  
 NSN 9535-00-167-2280  
 2024 AL ALY Sheet, Federal Specification QQ-A-250/5,  
 Temp 0 T42, 0.040 Inch Thick

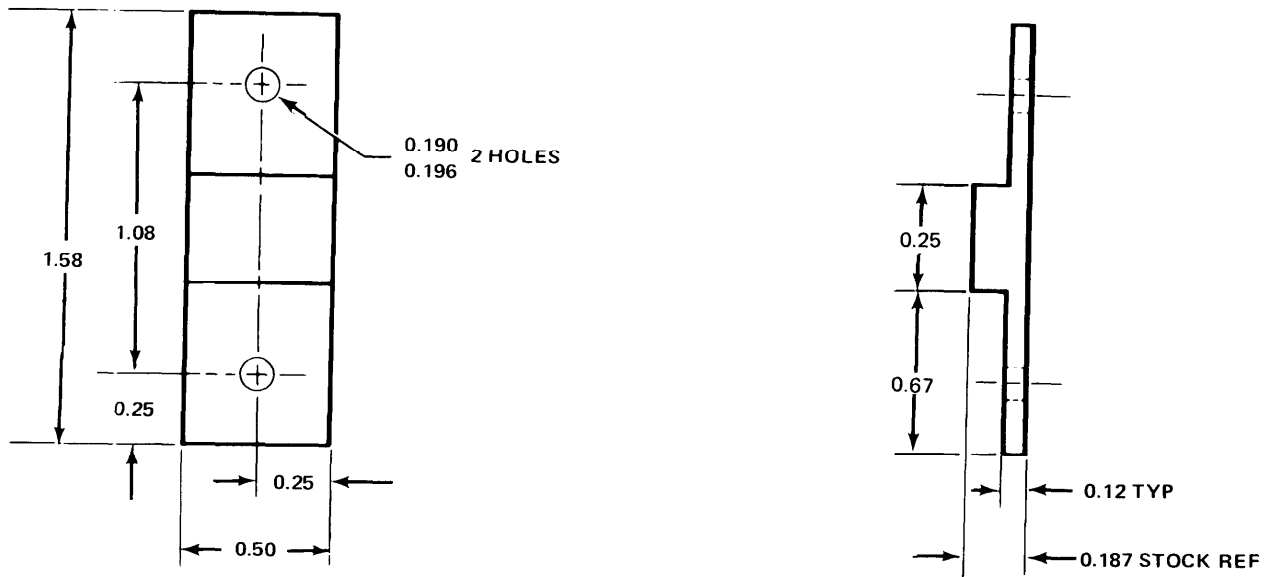


Figure D-140. Part Number  
Fabricate from:  
Material:

205-030-737-5 SPACER  
NSN 9330-00-290-3462  
Phenolic cotton fabric MIL-P-15035,  
Type FBM 0.1875 x 0.70 x 1.8

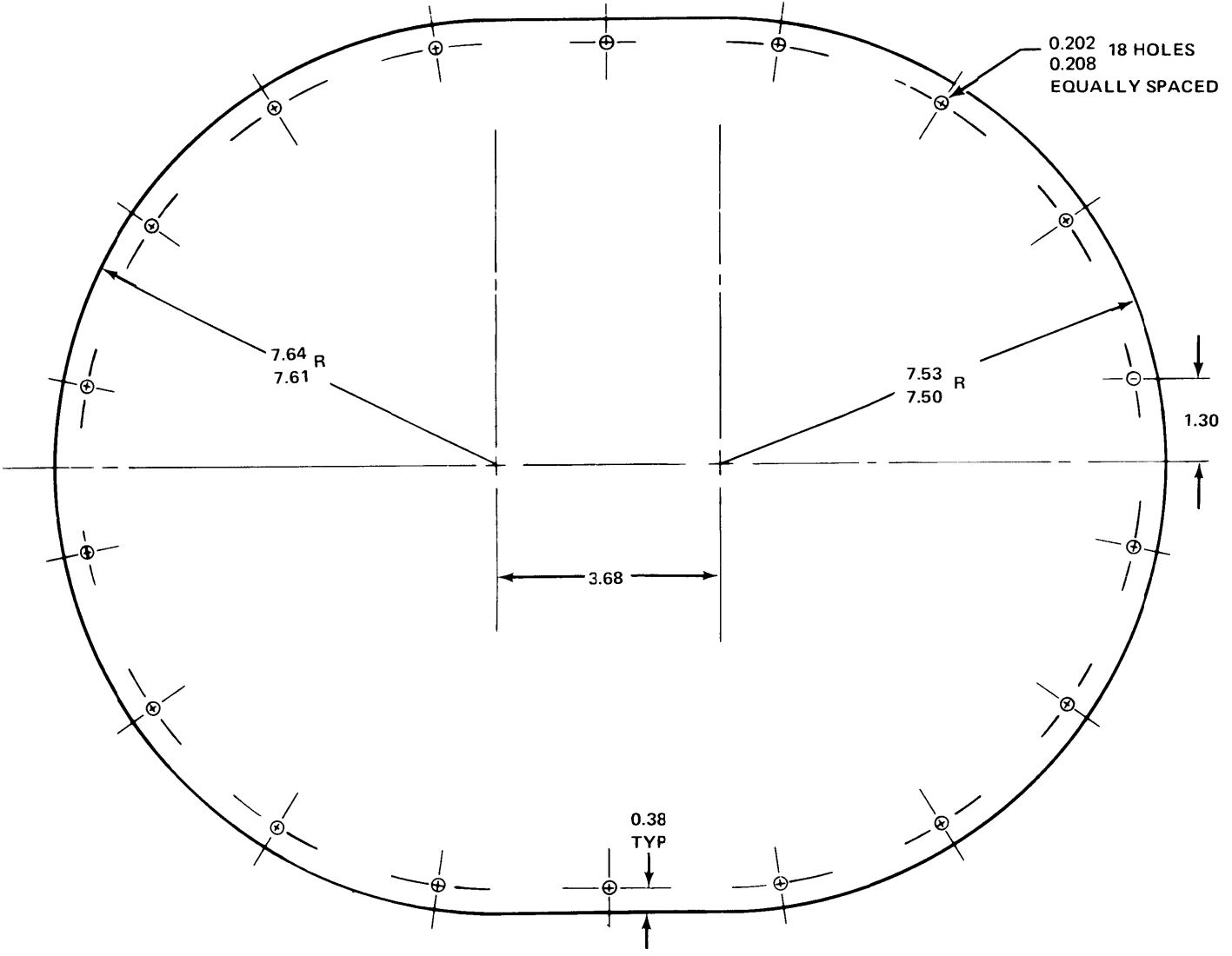


Figure D-141. Part Number 205-030-814-17 DOOR, Boom Access  
Fabricate from: NSN 9535-00-167-2279  
Material: 7075 AL ALY Sheet, Federal Specification QQ-A-250/13,  
Temp 0 to T6, 0.032 Inch Thick

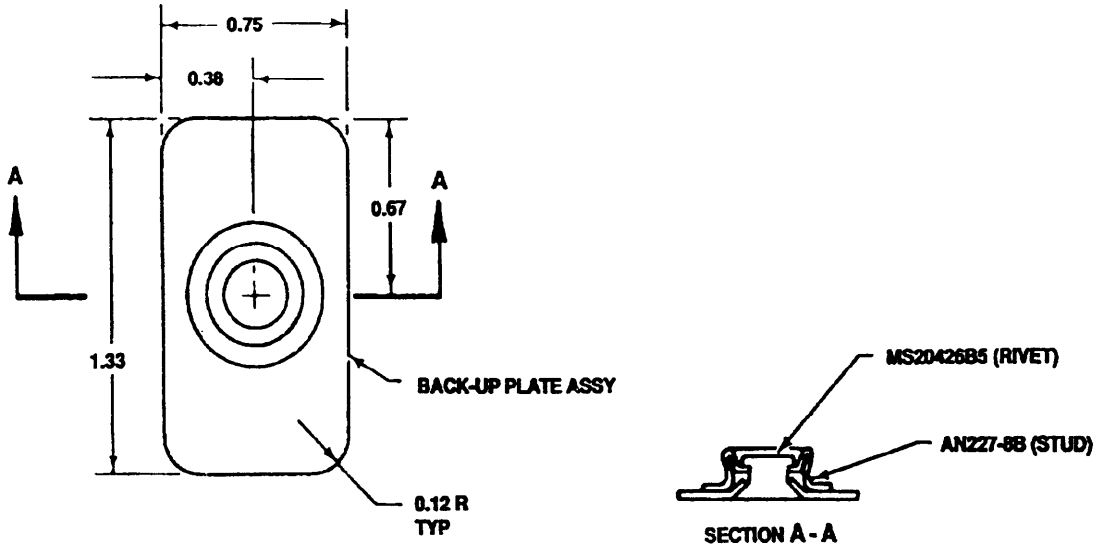
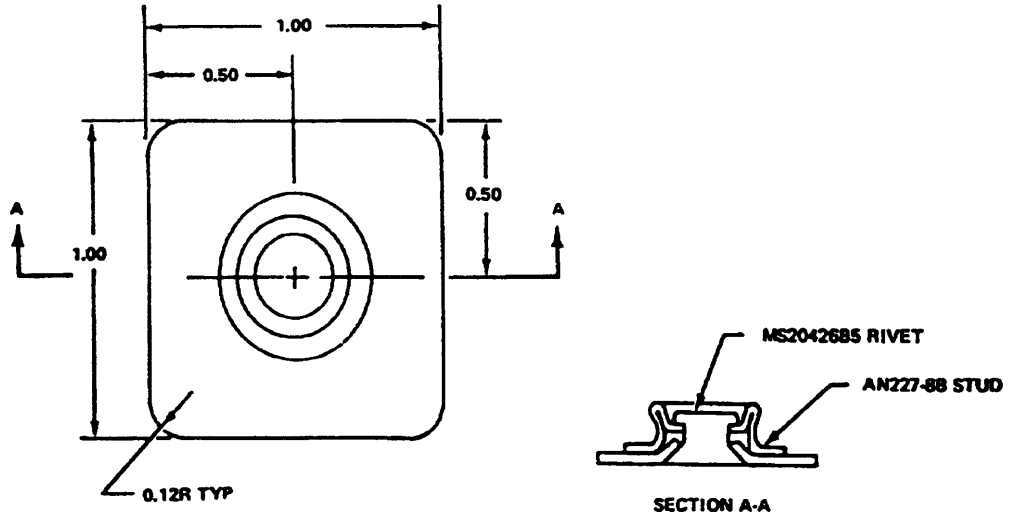


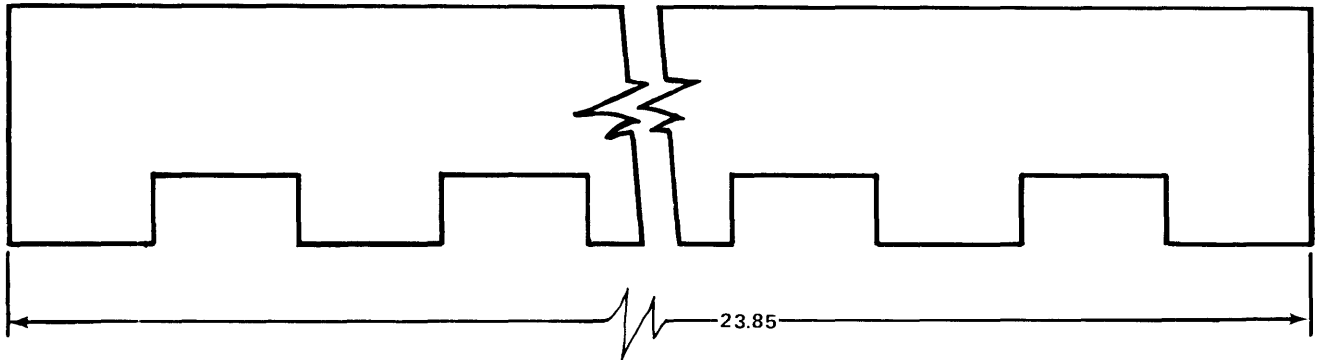
Figure D- 142. Part Number 100-057-I BACK-UP PLATE ASSY  
 Fabricate from: NSN 9535-00-167-2279  
 Material: 2024 AL ALY Sheet, Federal Specification QQ-A-250/5, T3, 0.032 Inch Thick  
 Stud-Snap Fastener, Metal (AN227-8B, Color Black)



**NOTE:**

- 1. INSTALL RIVETS PER BPS 4039**

Figure D- 143.	Part Number	100-057-5 BACK-UP PLATE ASSY
	Fabricate from:	NSN 9535-00-167-2279 NSN 5325-00-174-2923
	Material:	2024 AL ALY Sheet, Federal Specification QQ-A-250/5, T3, 0.032 Inch Thick Stud-Snap Fastener, Metal (AN227-8B, Color Black)



NOTE: ZINC CHROMATE FINISH

<b>Figure D-144. Part Number</b>	<b>205-030-849-7 HINGE, Half</b>
<b>Fabricate from:</b>	<b>NSN 5340-00-993-1461</b>
<b>Material:</b>	<b>Leaf Butt Hinge, Aluminum, 0.040 Inch Thick, Make from MS20257HP2-2400 Material</b>

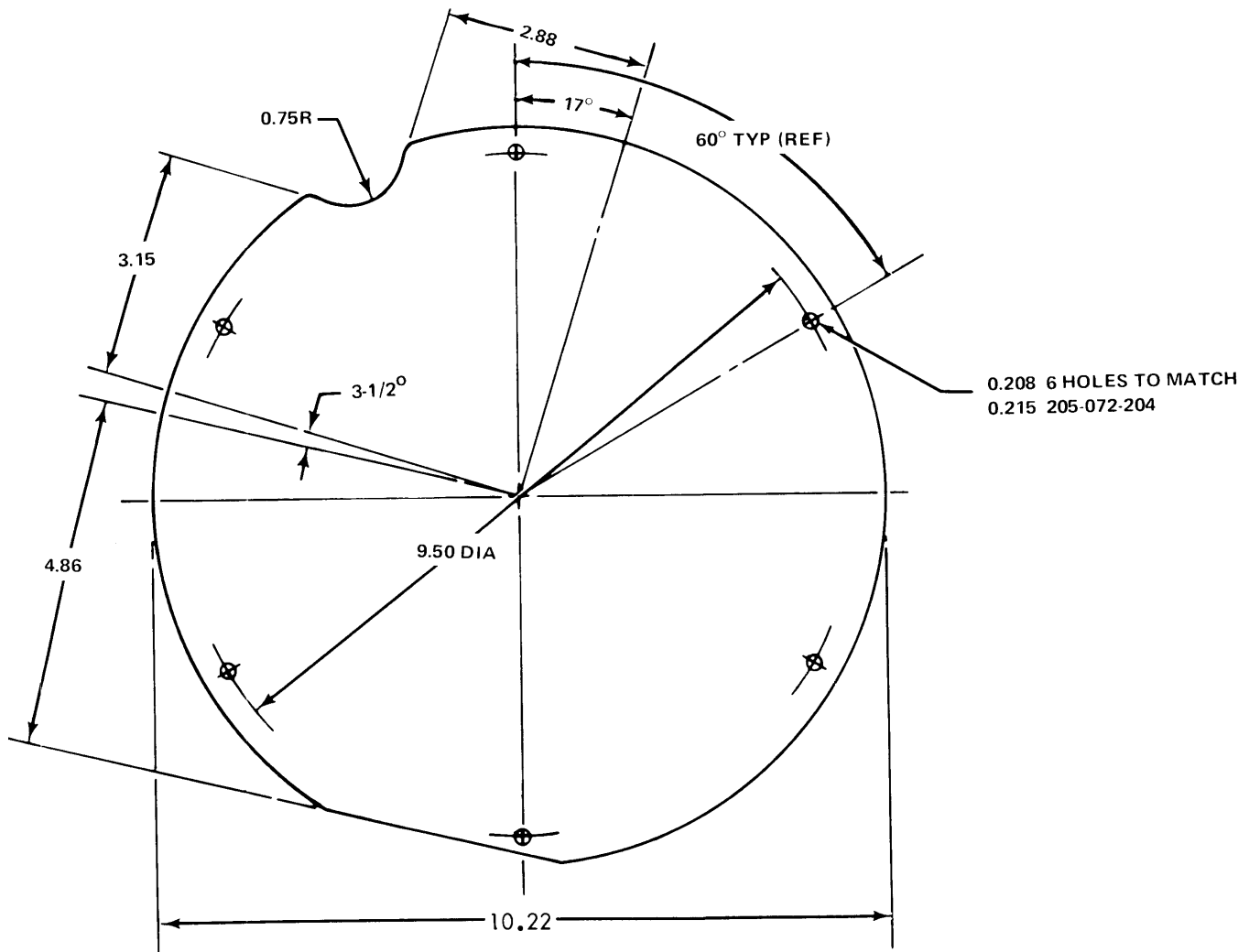


Figure D-145.

Part Number  
Fabricate from:  
Material:

205-031-137-1 COVER, Access Aircraft Components  
NSN 9535-00-086-9729  
2024 AL ALY Sheet, Federal Specification QQ-A-250/5,  
0.032 Inch Thick

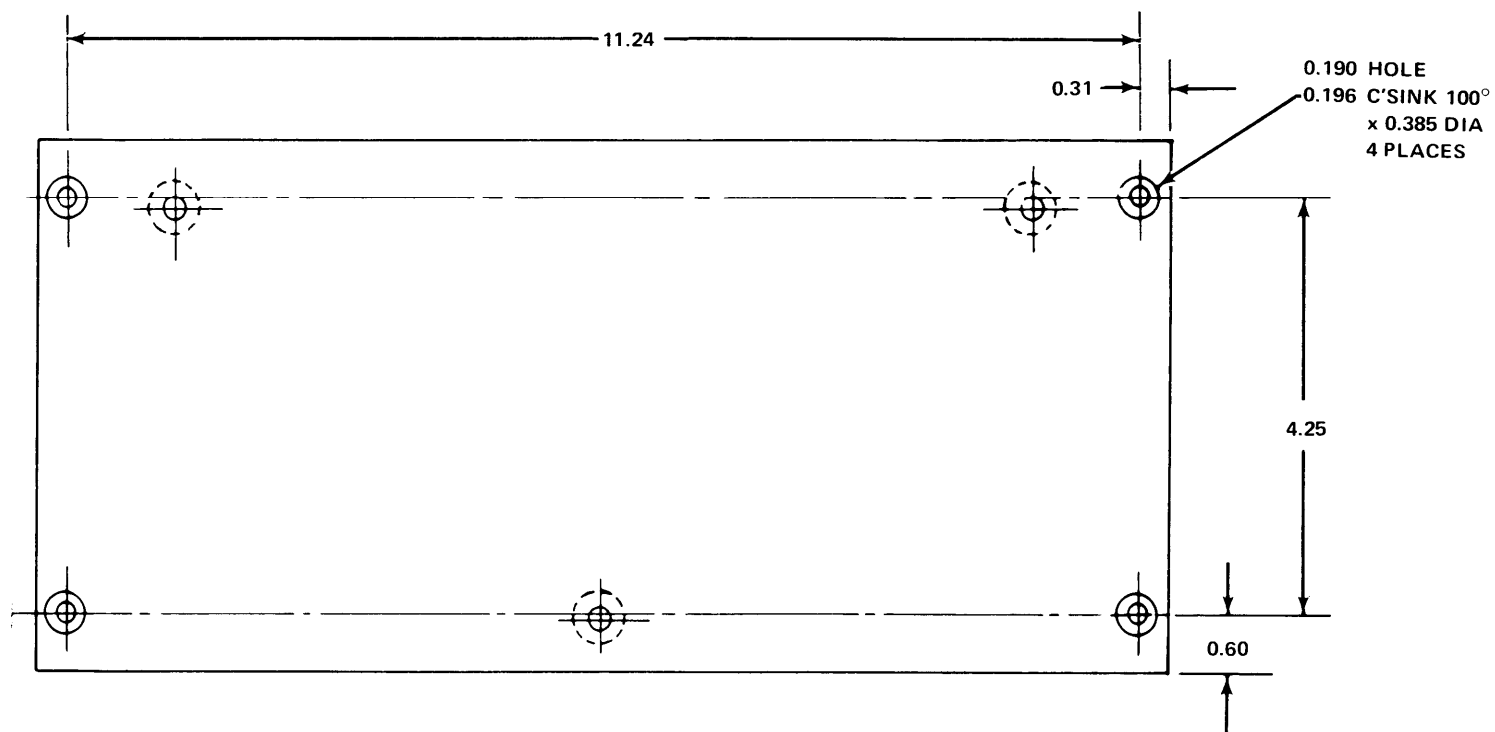


Figure D-146. Part Number  
Fabricate from:  
Material:

205-031-250-13 BASE PLATE  
NSN 1560-00-903-0798  
Fabricate From E9161-BP  
A Product of Laboratory  
For Electronics, Inc.,  
Boston, Mass  
Code Ident No. 82598



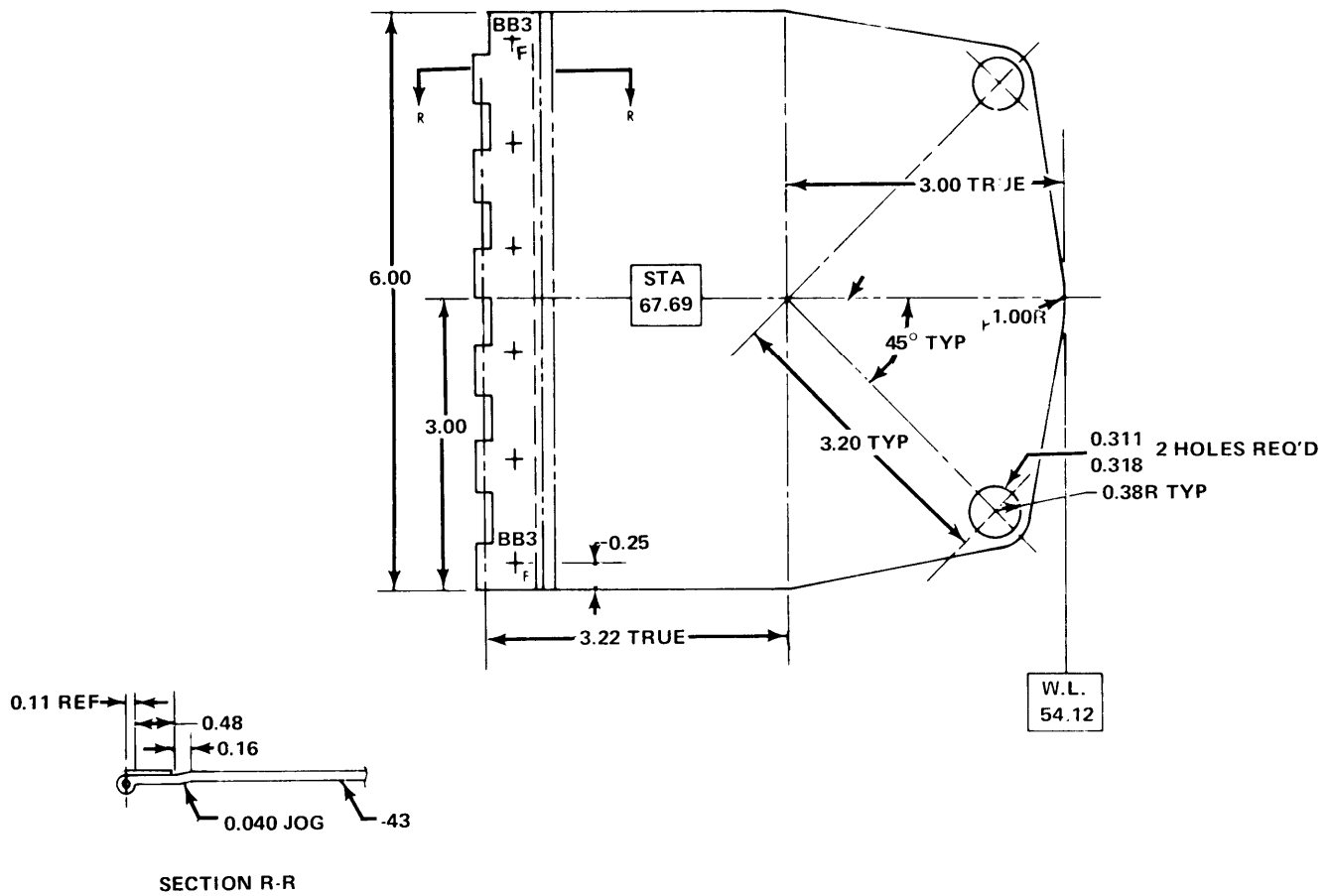


Figure D-147. Part Number  
Fabricate from:  
Material:

205-031-668-43 DOOR ASSEMBLY  
NSN 9535-00-167-2278  
2024 AL ALY Sheet, Federal Specification QQ-A-250/5,  
Temp T3, 0.025 Inch Thick

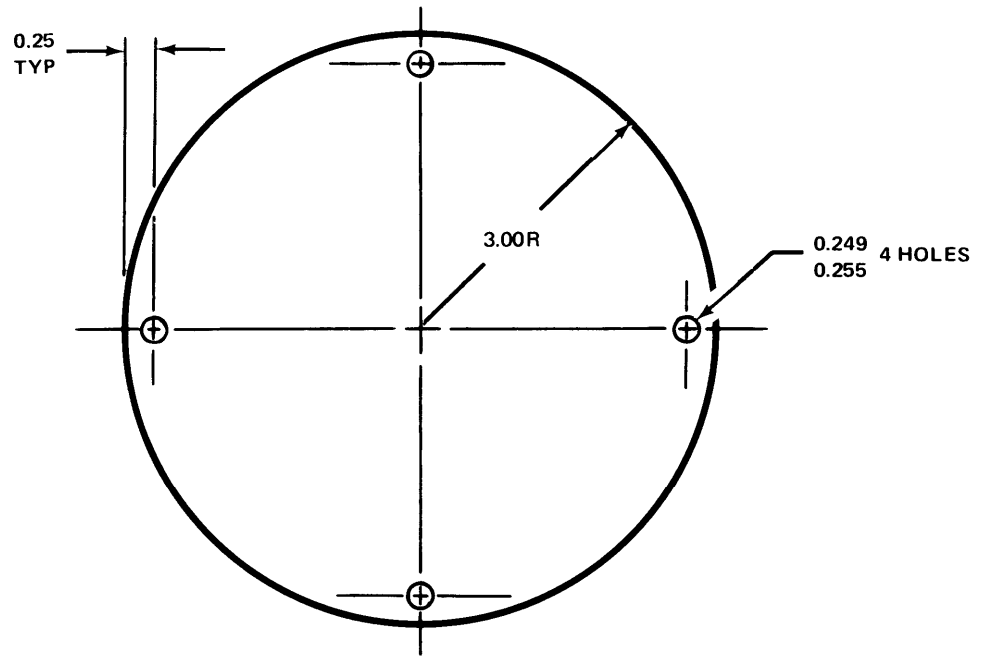


Figure D-148. Part Number 205-031-668-53, COVER PLATE  
Fabricate from: NSN 9535-00-167-2278  
Material: 2024 AL ALY Sheet, Federal Specification QQ-A-250/5, 0.025 Inch Thick

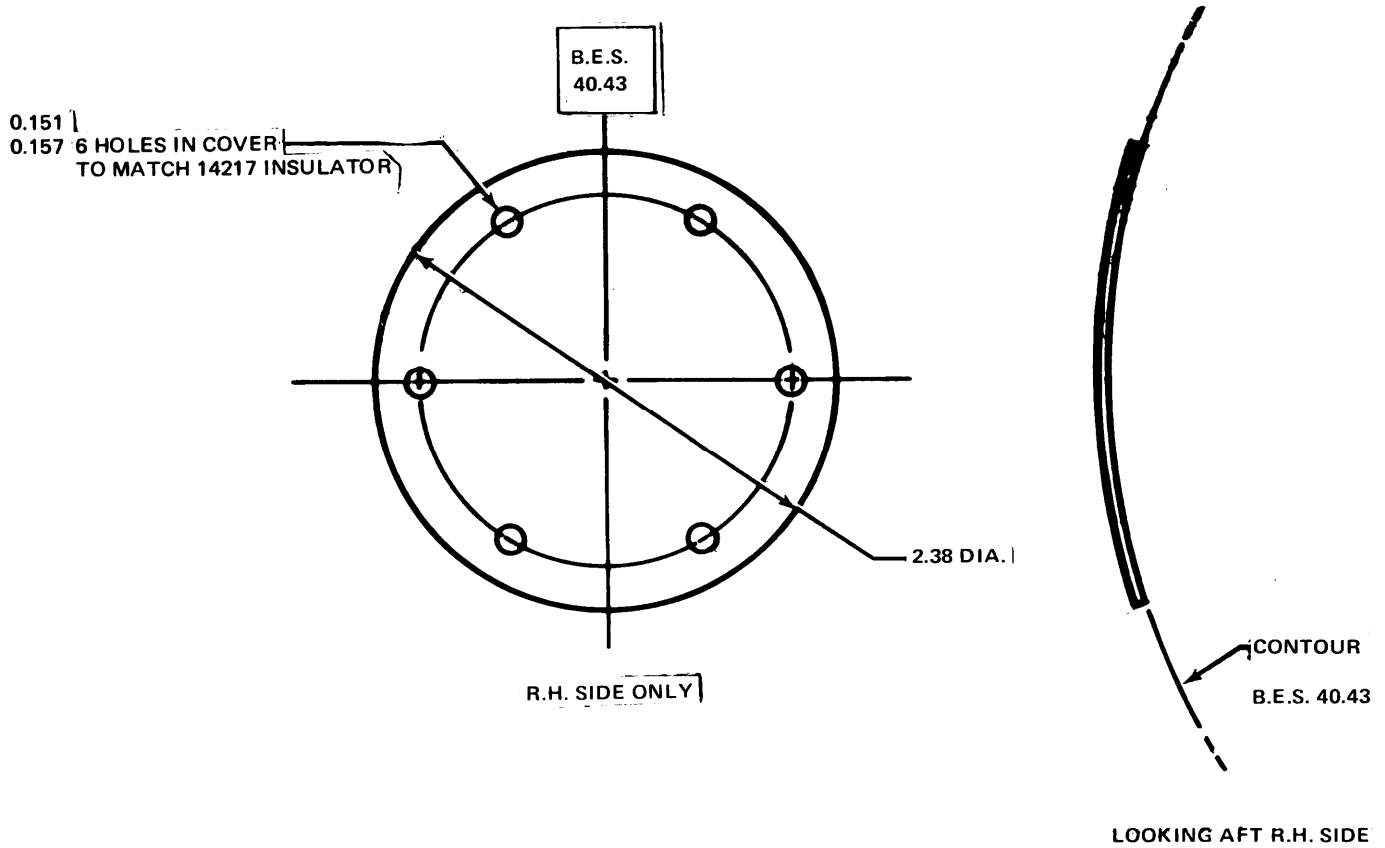
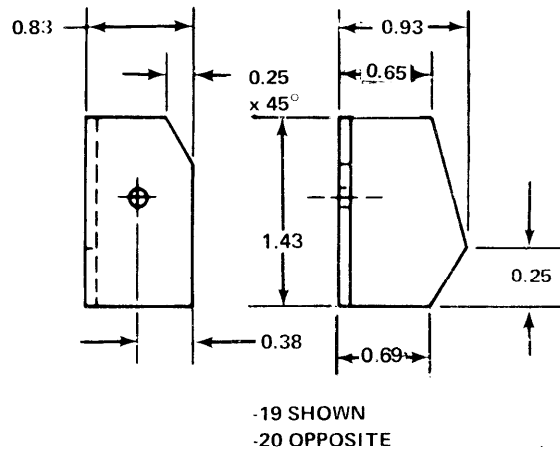
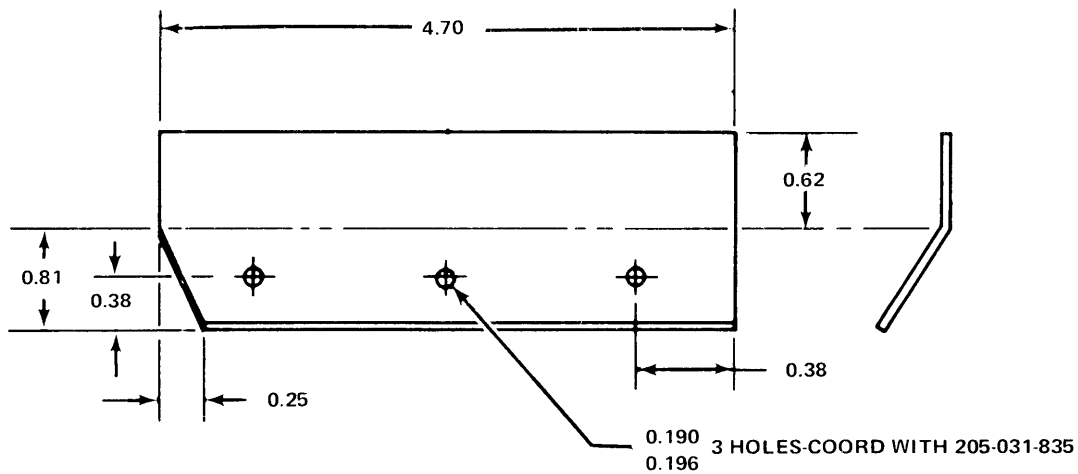


Figure D-149. Part Number 205-031-801-53 COVER, Tailboom  
Fabricate from: NSN 9535-00-167-2278  
Material: 2024 AL ALY Sheet, Federal Specification QQ-A-250/5,  
Temp T3, 0.025 Inch Thick



NOTES

1. 0.18 BEND RADII
2. BOND TO 205-031-837-9 WITH  
NSN 8040-00-788-2839 EC2216 CEMENT.  
(FOR -19 & -20 ONLY)



**Figure D-150.** Part Number 205-031-837-19, -20, -21 CLIP  
 Fabricate from: NSN 9535-00-640-2311  
 Material: 2024 AL ALY Sheet, Federal Specification QQ-A-362,  
 Temp T3, 0.050 Inch Thick

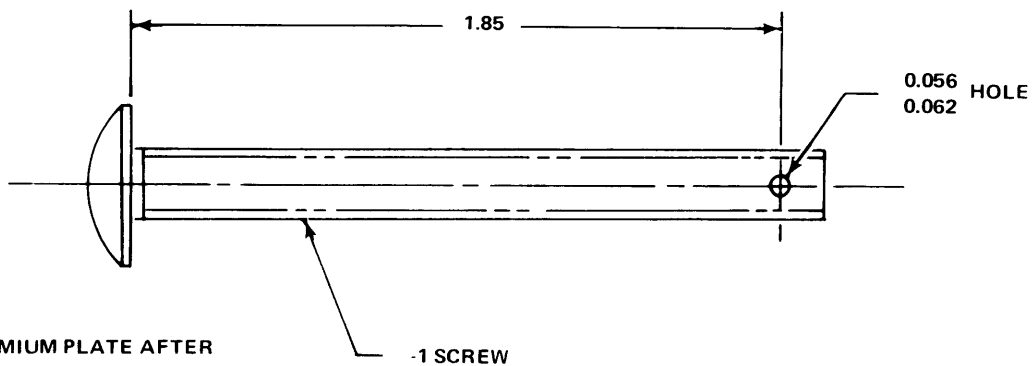


Figure D-151. Part Number 205-031-898-1 SCREW  
 Fabricate from: NSN 5305-00-995-6311  
 Material:

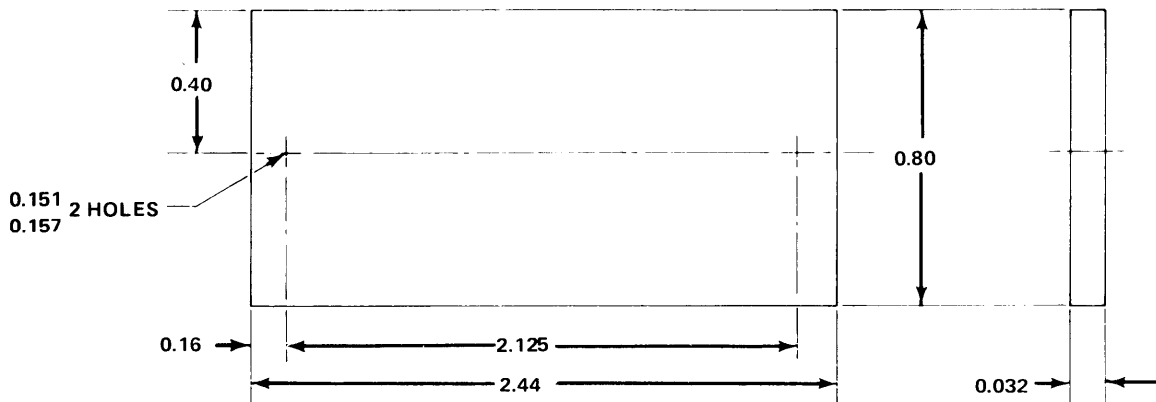
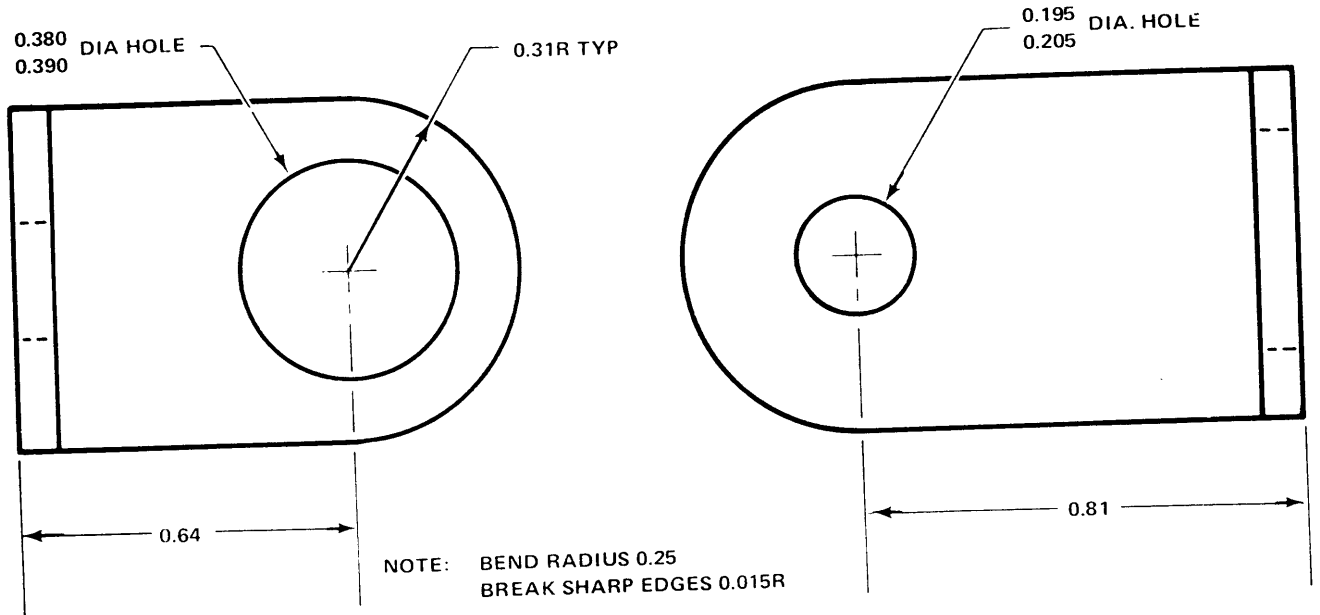


Figure D-152. Part Number 204-031-136-17 COVER  
 Fabricate from: NSN 9535-00-167-2279  
 Material: AL ALY Sheet, Federal Specification QQ-A-250/5,  
 Temp T3, 0.032 Inch Thick



**Figure D-153.**

Part Number  
Fabricate from:  
Material:

205-040-131-1, BRACKET, Support, Oil Line, Transmission  
NSN 9535-00-232-0378  
2024 AL ALY Sheet, Federal Specification QQ-A-250/5, 0.063 Inch Thick

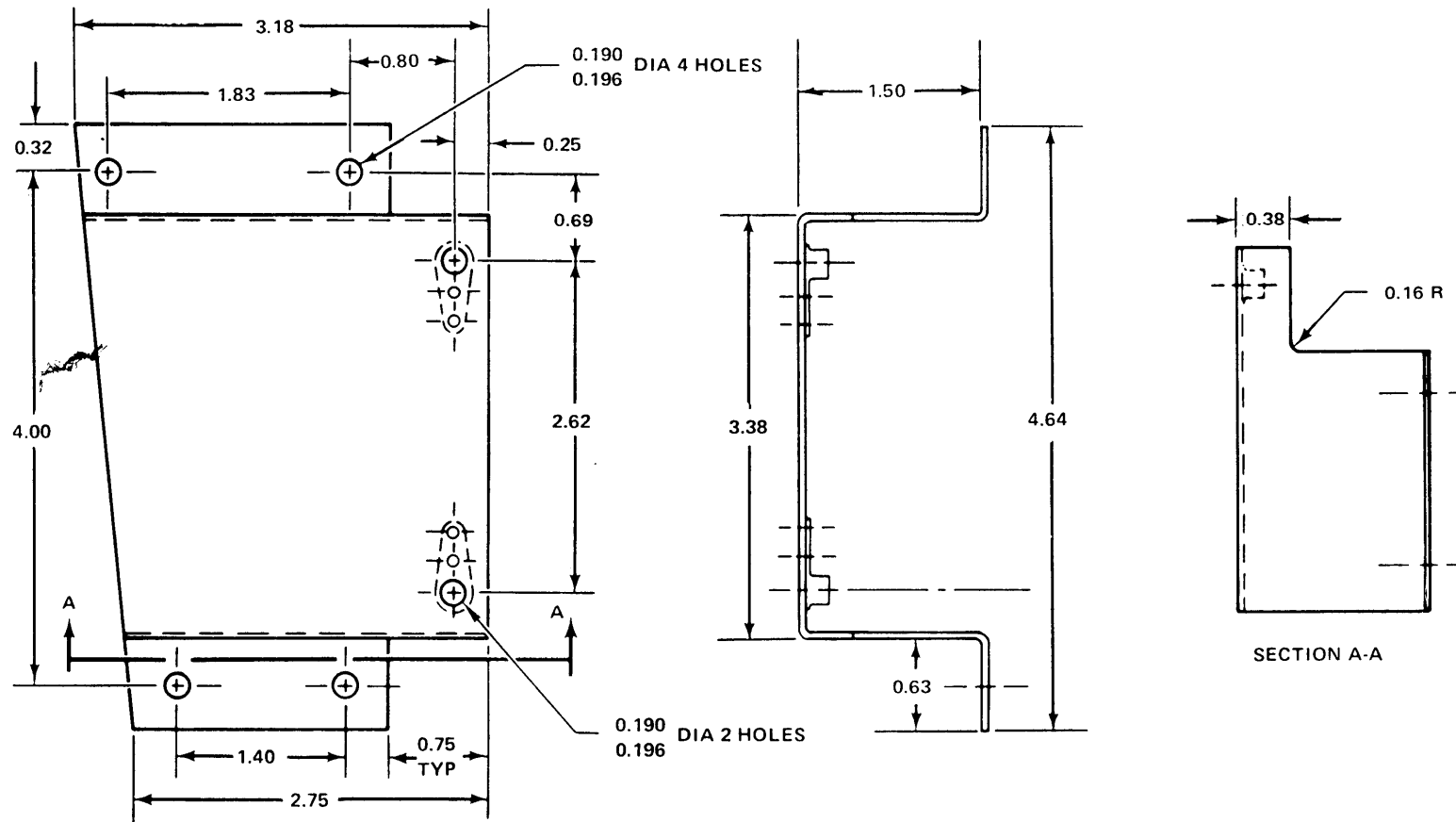
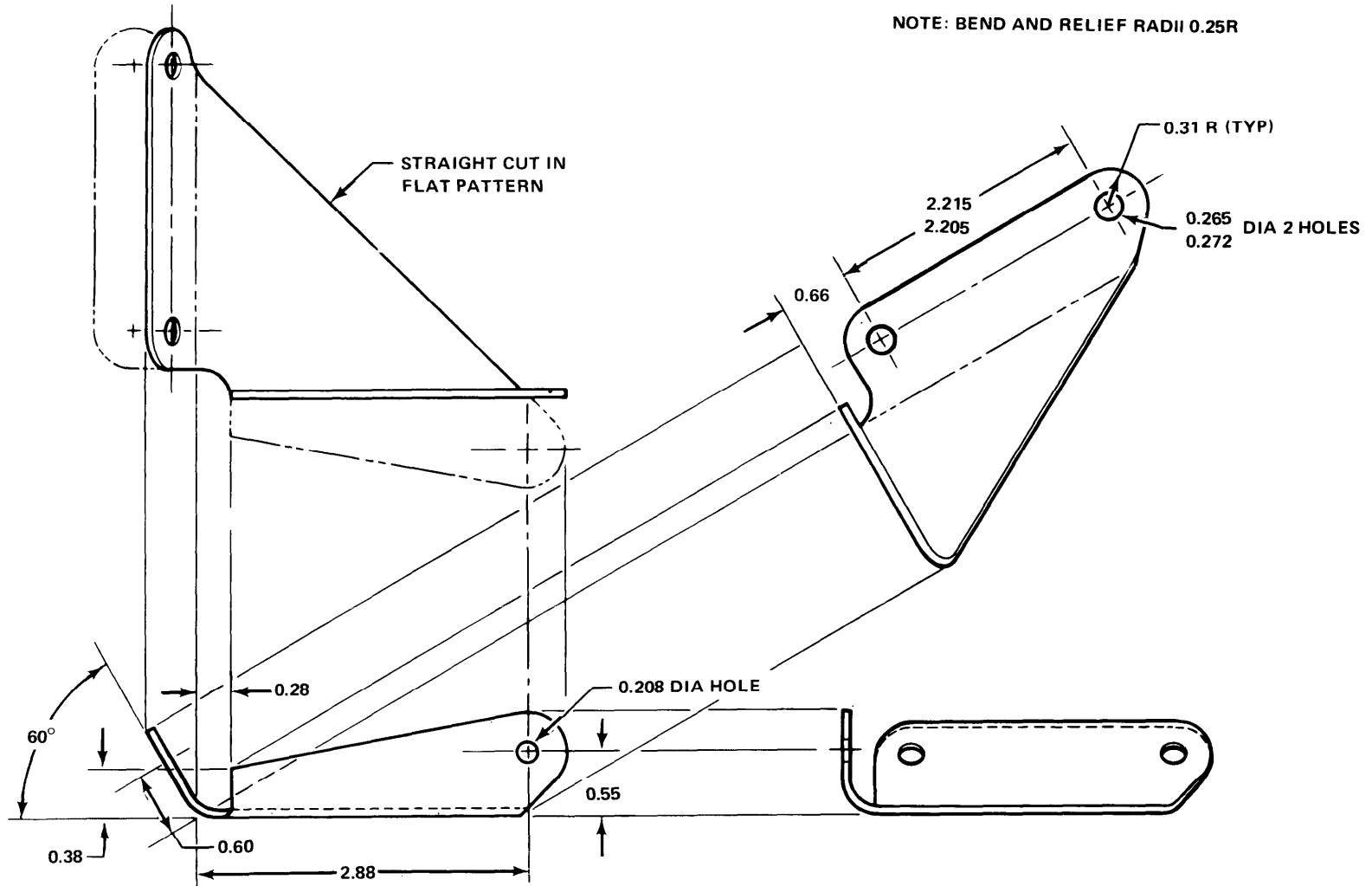


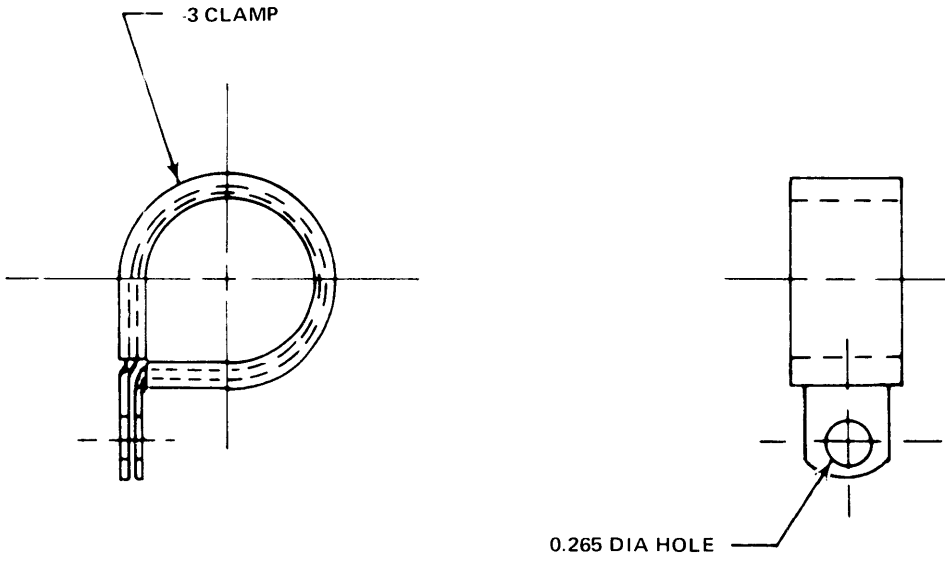
Figure D-154. Part Number  
Fabricate from:  
Material:

206-040- 162-1 BRACKET ASSEMBLY, Transmission Oil  
NSN 9636-00-086-9729  
2024 AL ALY Sheet, Federal Specification QQ-A-360/5,  
0.032 Inch Thick



**Figure D-155.** Part Number 205-040-154-3, BRACKET, Flex Hose Support  
 Fabricate from: NSN 9535-00-232-0378  
 Material: 2024 AL ALY Sheet, Federal Specification QQ-A-250/5, 0.0631 Inch Thick

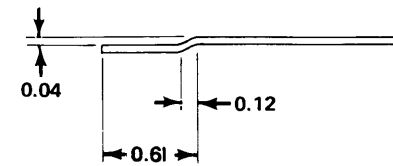
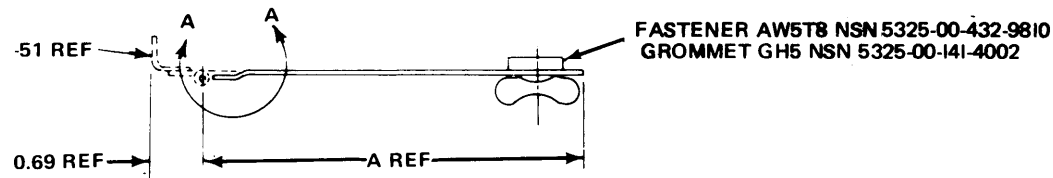




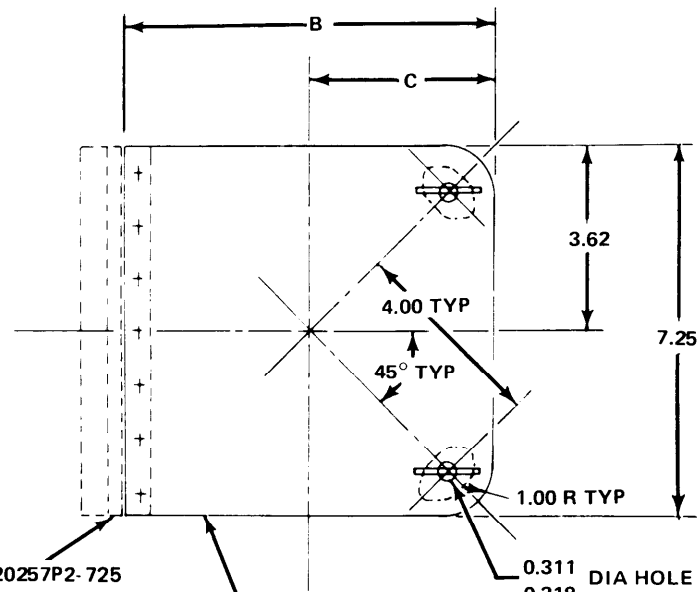
NOTES:  
BREAK SHARP EDGES 45° x 0.010

**Figure D-156.** Part Number 205-040-156-3 CLAMP, Hose  
Fabricate from: NSN 5340-00-989-4571  
Material:

Figure D-156



DETAIL A-A



NOTES:

1. APPLY A CHEMICAL FILM  
NSN 8030-00-829-0376  
TM 55-405-3 MANUAL
2. APPLY 1 COAT ZINC CHROMATE  
PRIMER NSN 8010-00-899-8825 PER  
TB 746-93-2, FOLLOWING APPLICATION  
OF CHEMICAL FILM

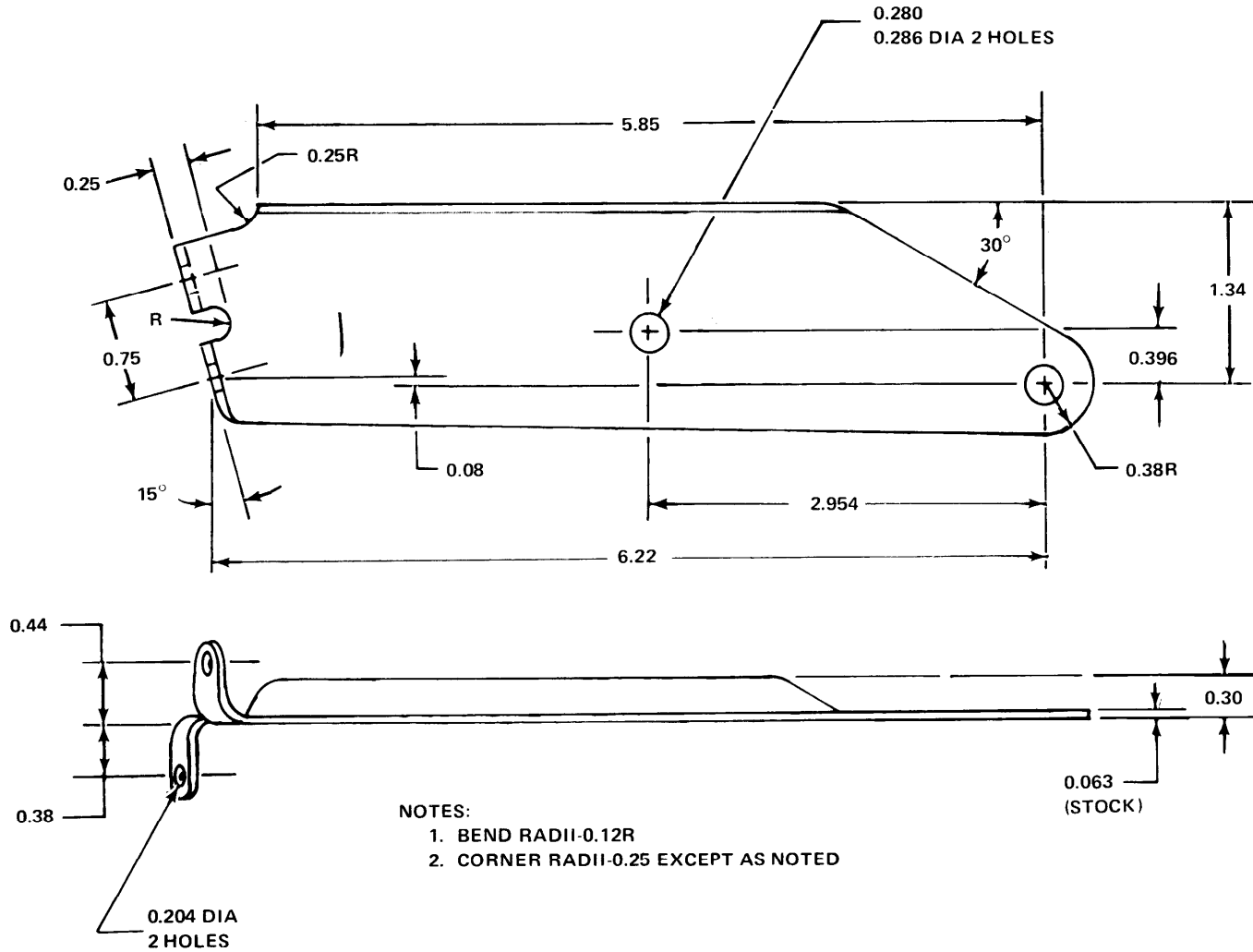
PART NUMBER	A	B	C
205-030-245-67	6.97	6.83	3.56
205-030-245-61	7.35	7.24	3.74

FOR HINGE HALF USE MS20257P2-725  
NSN 5340-00-250-4970 AND CUT TO  
7.25 IN. LG TO MATE WITH EXISTING  
HINGE HALF. DRILL 7 HOLES EQ SPACED  
FOR MS20426AD3 RIVET. HOLES TO BE  
DRILLED AT TIME OF INSTALLATION.

205-030-245-69 DOOR  
205-030-245-63 DOOR  
FABRICATE FROM NSN 9535-00-167-2278

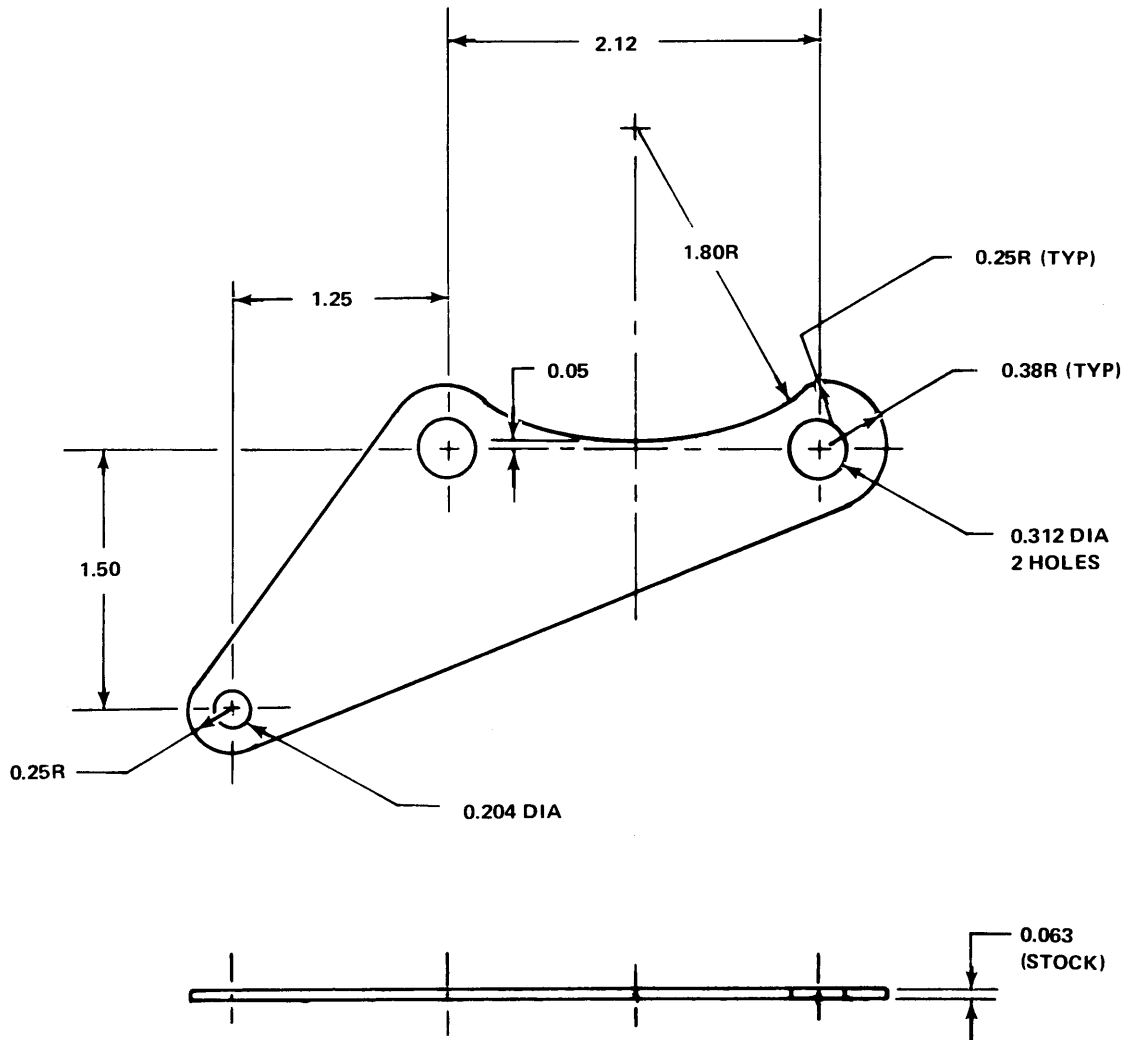
DOOR ASSEMBLY

Figure D-157



**Figure D-158.** Part Number 205-040-169-1 BRACKET, Hose Support  
 Fabricate from: NSN 9535-00-232-0378  
 Material: 2024 AL ALY Sheet, Federal Specification QQ-A-250/5, 0.063 Inch Thick

Figure D-158



**Figure D-159.** Part Number 205-040-170-1 BRACKET, Hose Support  
 Fabricate from: NSN 9535-00-232-0378  
 Material: 2024 AL ALY Sheet, Federal Specification QQ-A-250/5, 0.063 Inch Thick

Figure D-159

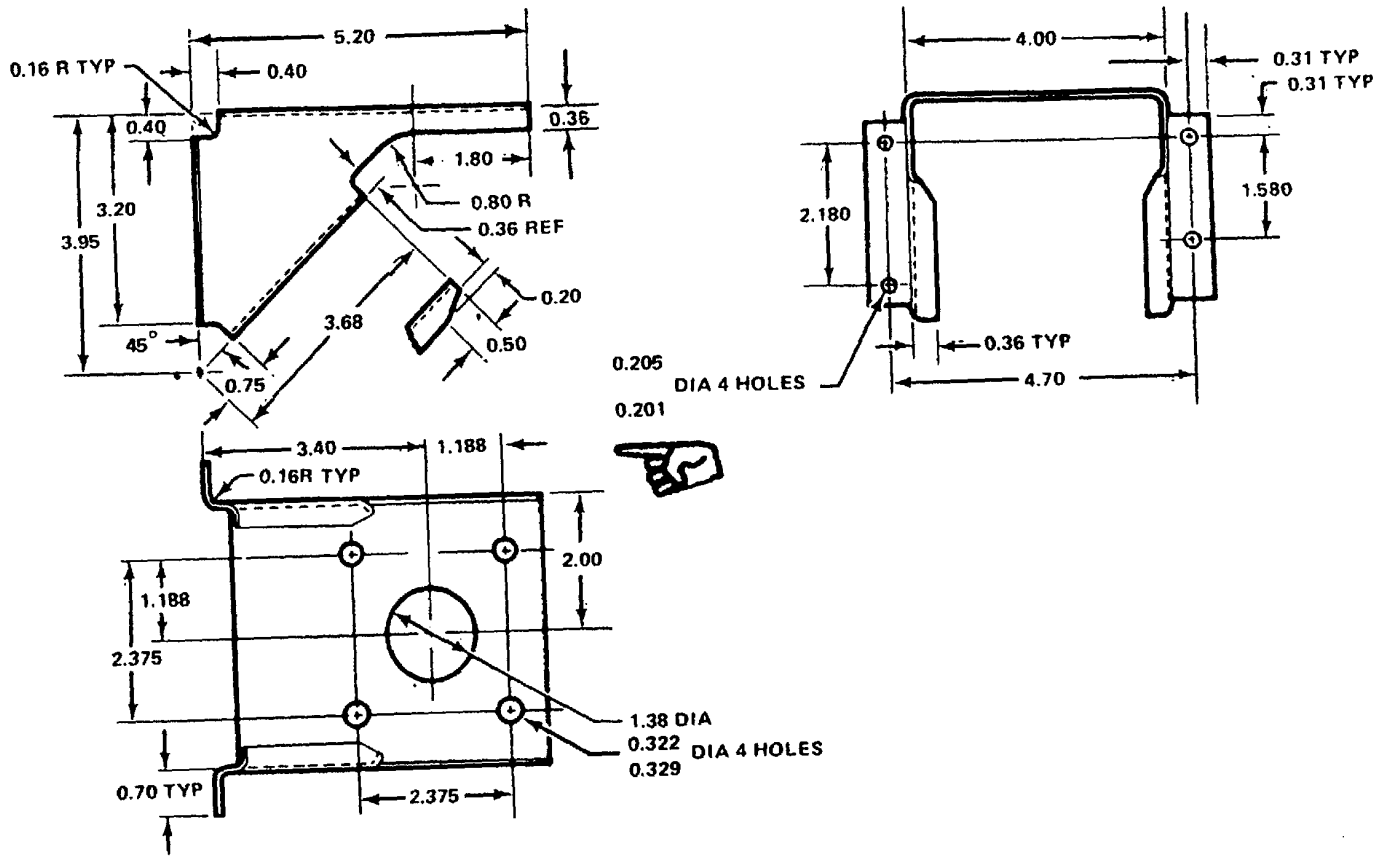
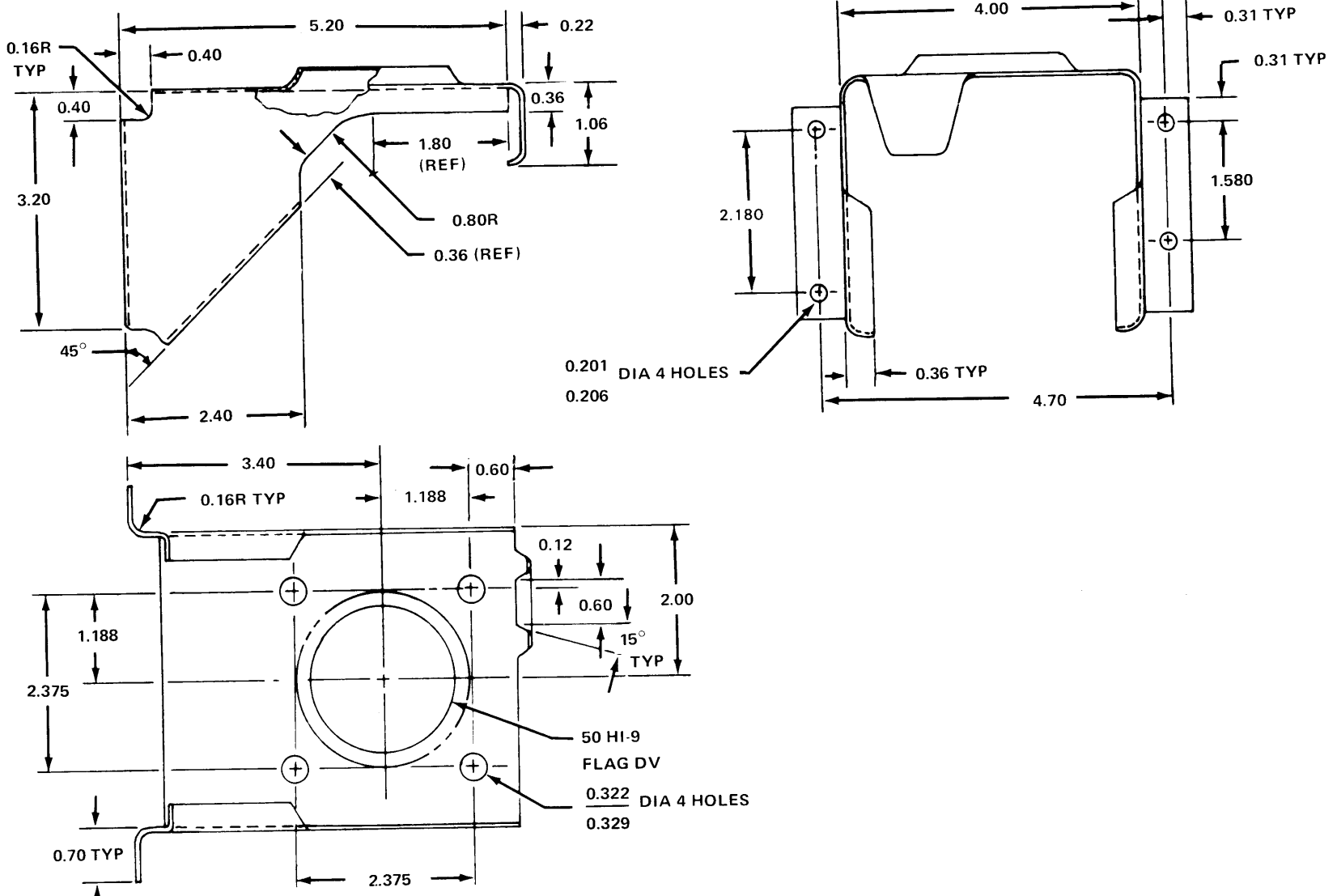


Figure D-160. Part Number 205-040-202-1, BRACKET, Transmission Oil Filter  
 Fabricate from: NSN 9535-0-167-2280  
 Material: 2024 AL ALY Sheet, Federal Specification QQ-A-250/5, 0.040 Inch Thick

Change 8 D-200



**Figure D-161.** Part Number 205-040-202-3, BRACKET, Transmission Oil Filter  
 Fabricate from: NSN 9535-00-167-2280  
 Material: 2024 AL ALY Sheet, Federal Specification QQ-A-250/5, 0.040 Inch Thick

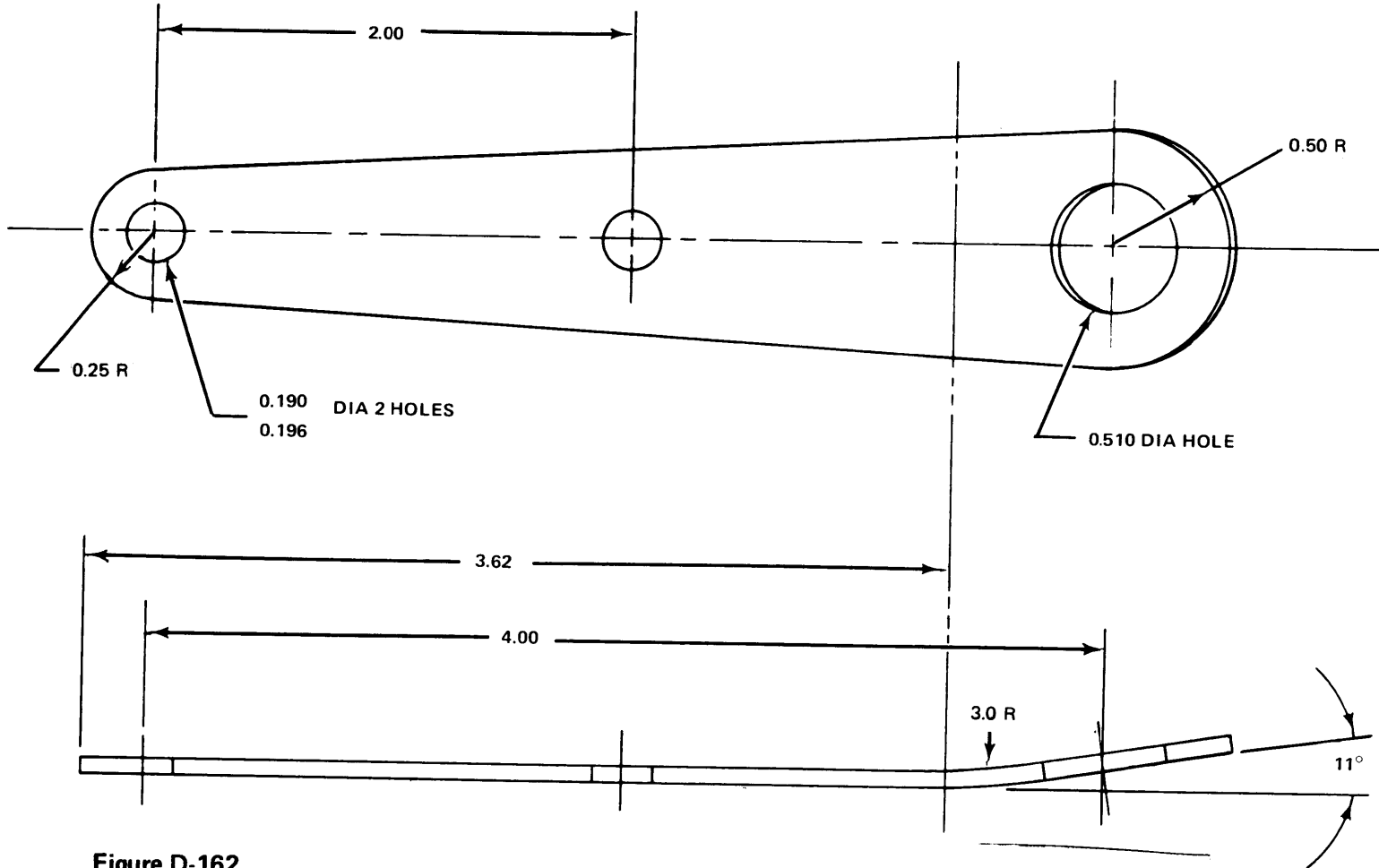
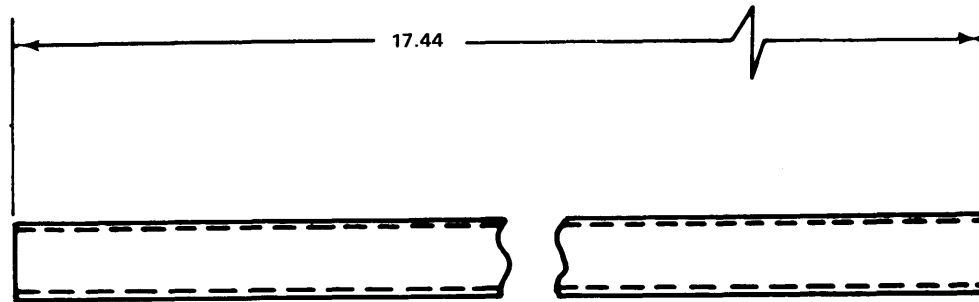
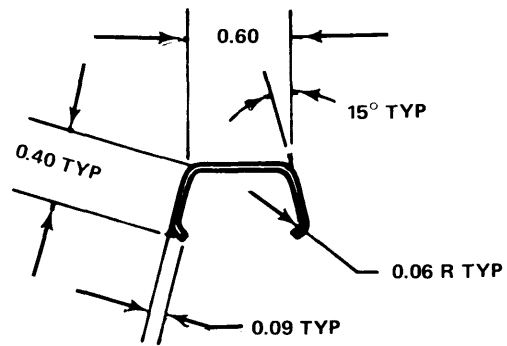


Figure D-162.

Figure D-162.

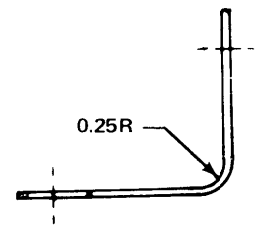
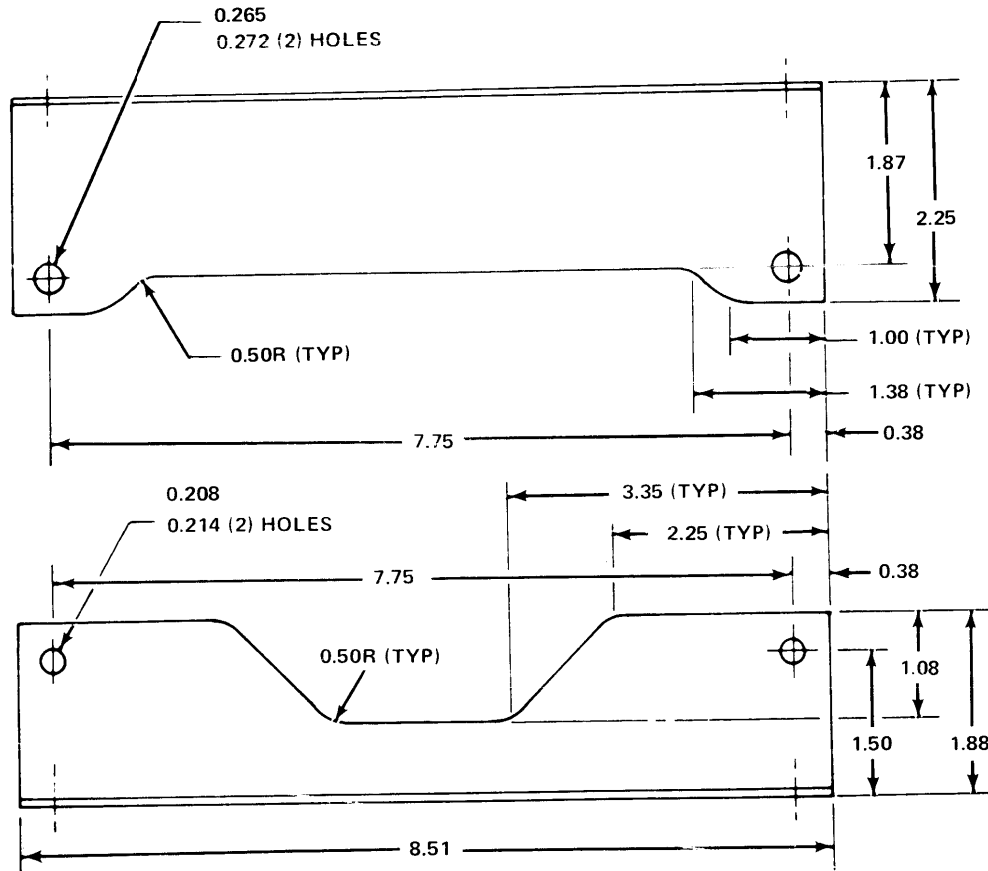
Part Number  
Fabricate from:  
Material:

205-060-020-7 BRACKET  
NSN 9535-00-232-0405  
2024 AL ALY Sheet, Federal Specification QQ-A-362,  
T3, 0.090 Inch Thick



**Figure D-163.** Part Number 205-060-204-1, CHANNEL RETAINER  
 Fabricate from: NSN 9535-00-232-0543 Zinc Chromate Finish  
 Material: 2024 AL ALY Sheet, Federal Specification QQ-A-250/5, 0.016 Inch Thick



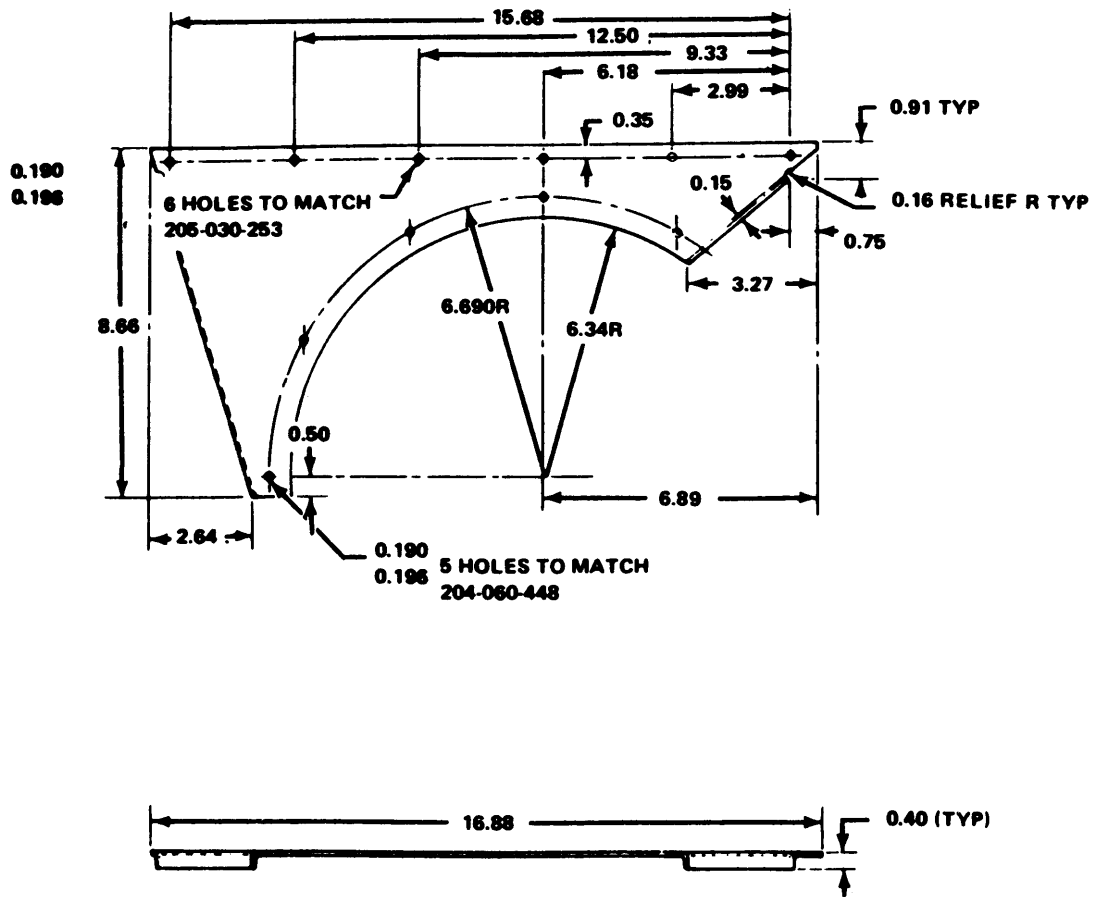


NOTES:

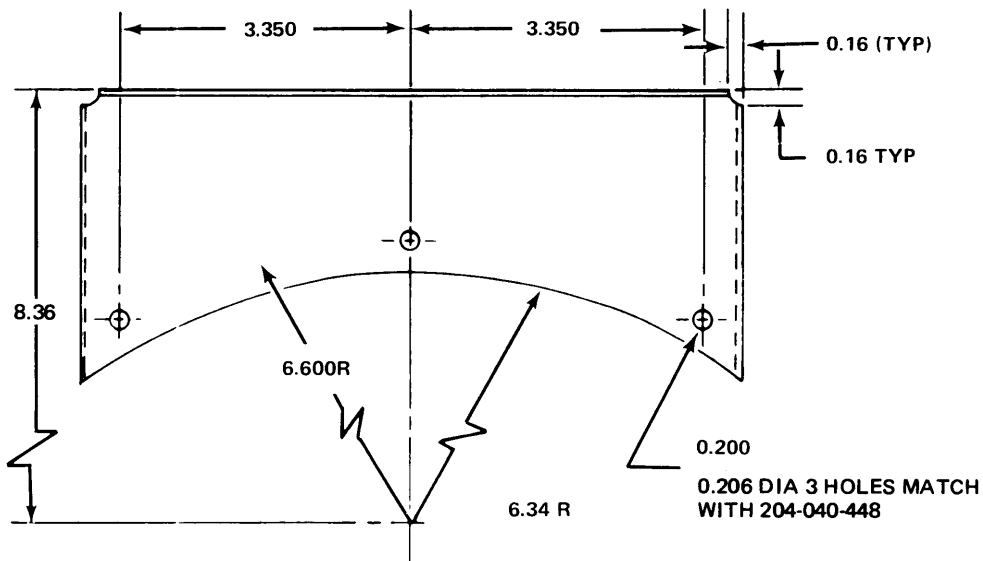
1. APPLY A CHEMICAL FILM NSN 8030-00-820-0376 PER TM 55-405-3 MANUAL.
2. APPLY TWO COATS OF ZINC CHROMATE PRIMER NSN 8010-00-899-8825 IMMEDIATELY FOLLOWING APPLICATION OF CHEMICAL FILM ALLOWING TIME FOR DRYING BETWEEN COATS.

Figure D-164.

Part Number 205-072-264-1 BRACKET, Angle  
 Fabricate from: NSN 9543-00-232-0378  
 Material: 2024 AL ALY Sheet, Federal Specification QQ-A-250/4, 0.063 Inch Thick



**Figure D-165.** Part Number 205-060-509-3 BRACKET, Oil Cooler Fan  
 Fabricate from: NSN 9535-00-232-0569 Zinc Chromate Finish  
 Material: 2024 AL ALY Sheet, Federal Specification QQ-A-250/5, 0.050 Inch Thick



- NOTES:
1. BEND RADII TO BE 0.09
  2. ALL RELIEF RADII 0.16
  3. ALL CORNER RADII 0.25

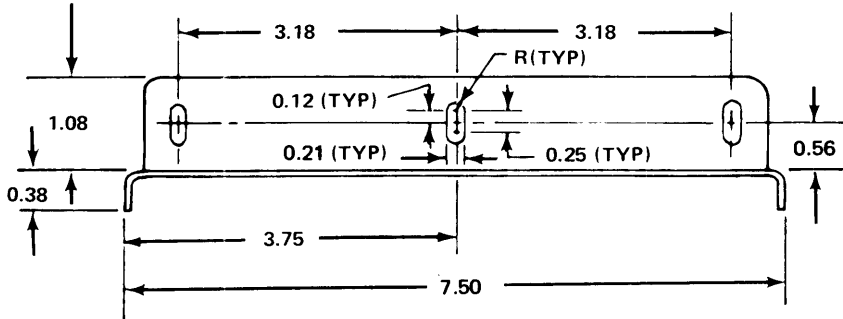
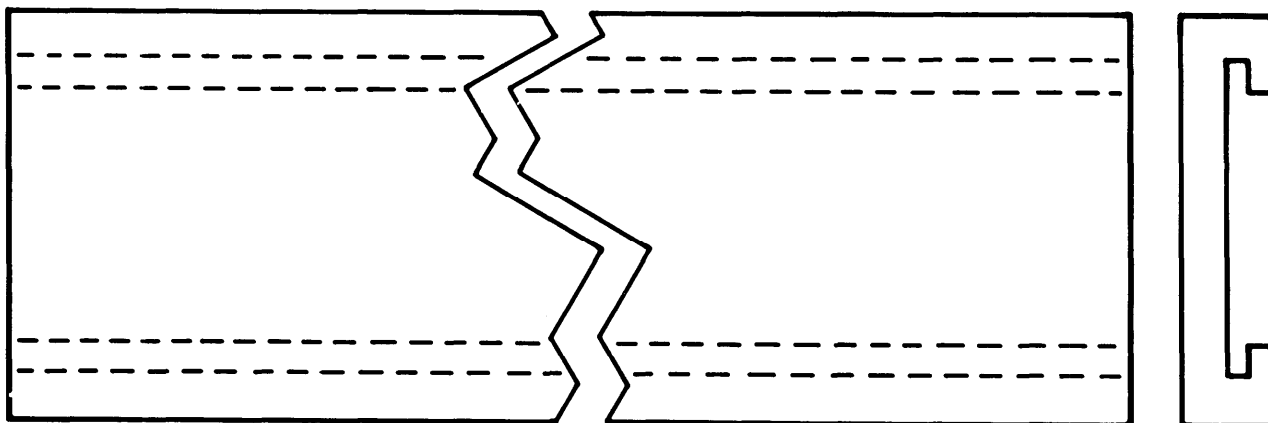
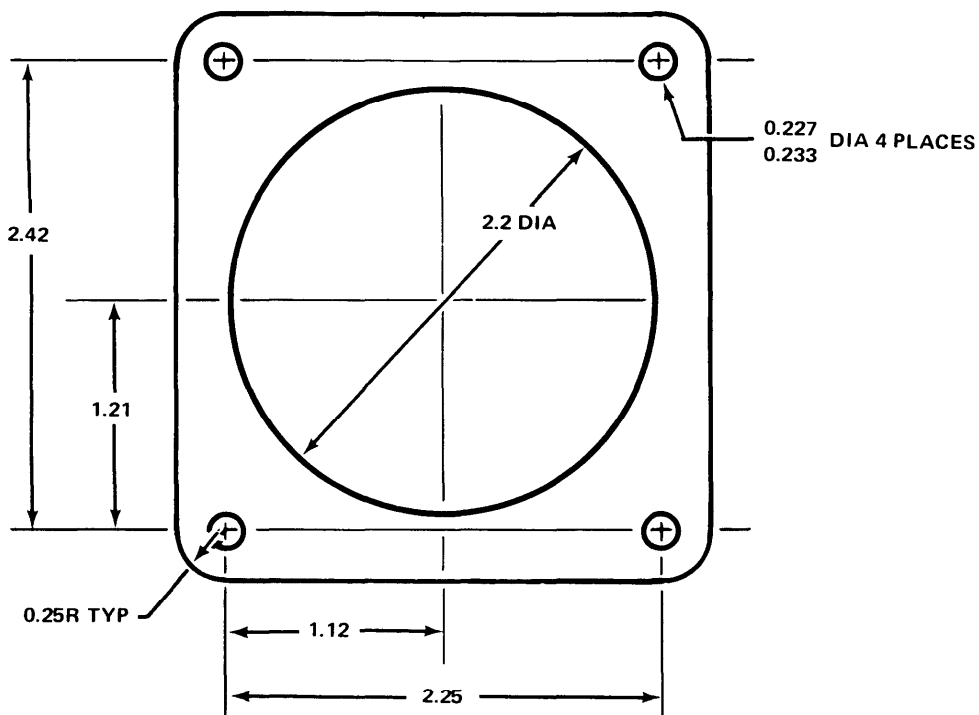


Figure D-166. Part Number 205-060-536-1 BRACKET, Transmission Oil Cooler  
 Fabricate from: NSN 9535-00-167-2278  
 Material: 2024 AL ALY Sheet, Federal Specification QQ-A-362-T3  
 0.025 Inch Thick



**Figure D-167.** Part Number 205-060-540-19, PAD, Oil Tank Support Assembly  
 Fabricate from: NSN 9390-00-263-0061  
 Material: Nonmetallic Channel Synthetic Rubber, Fuel and Oil Resistant, 1-1/4 In. Wide, 2.81 In. High, 60 Inch Long



**Figure D-168.** Part Number 205-060-770-1 SHIM, Jackshaft Support  
 Fabricate from: NSN 9535-00-167-2279  
 Material: 2024 AL ALY Sheet, Federal Specification QQ-A-362-T3, 0.032 Inch Thick

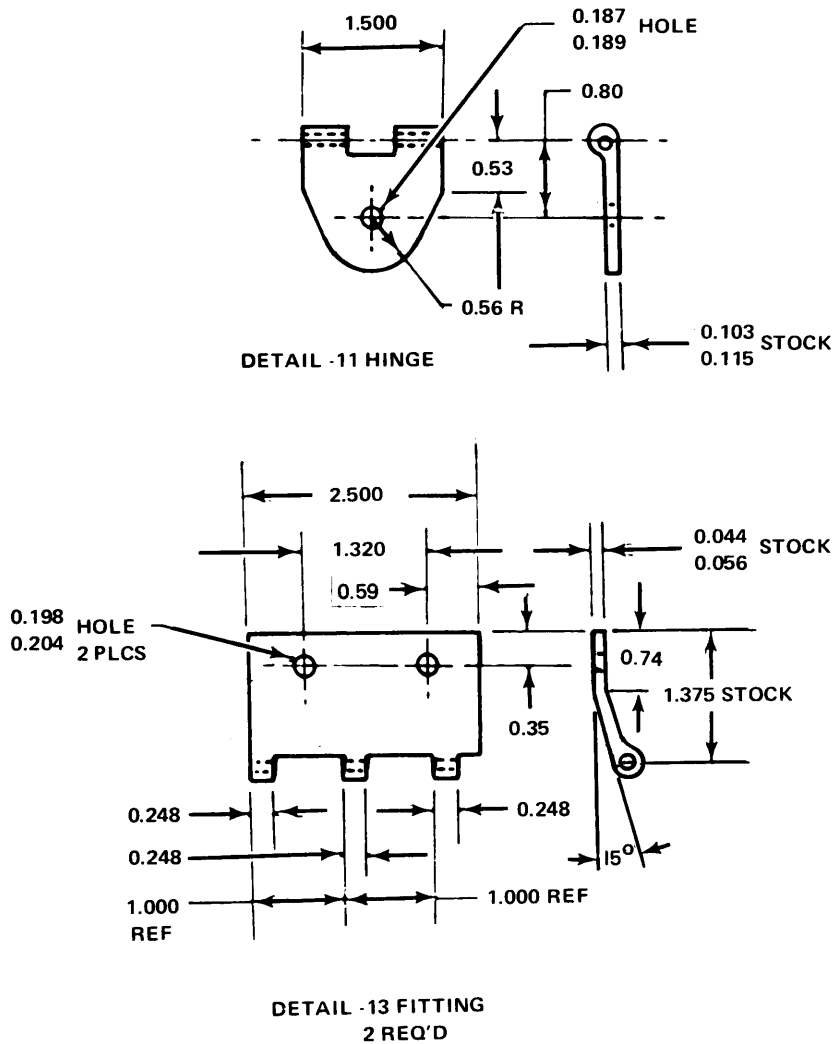
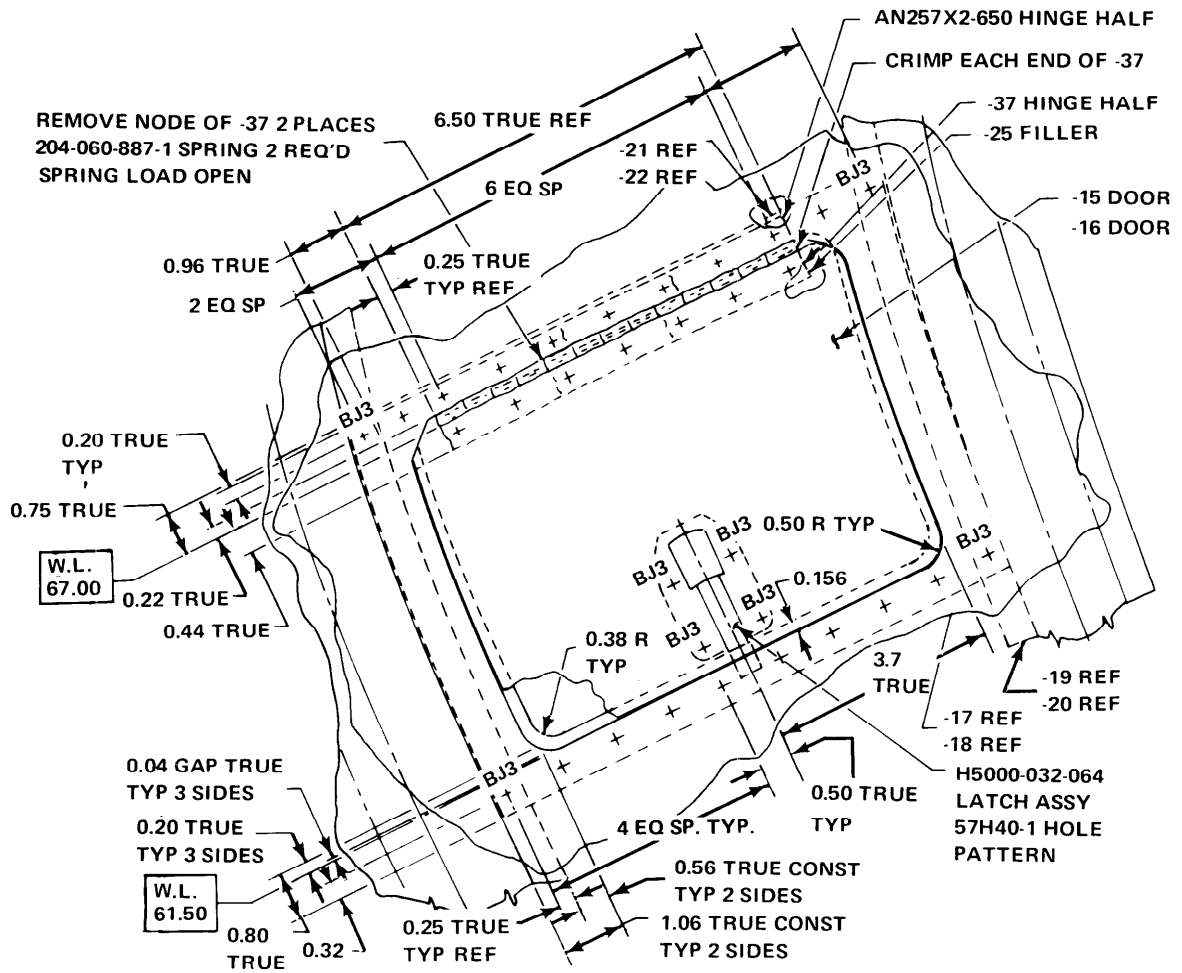
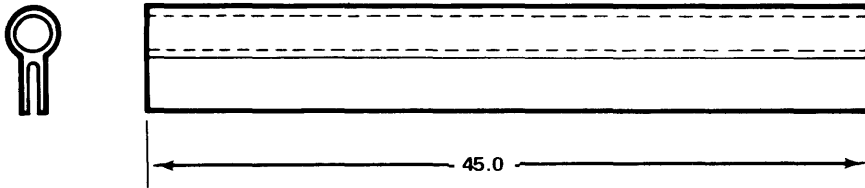


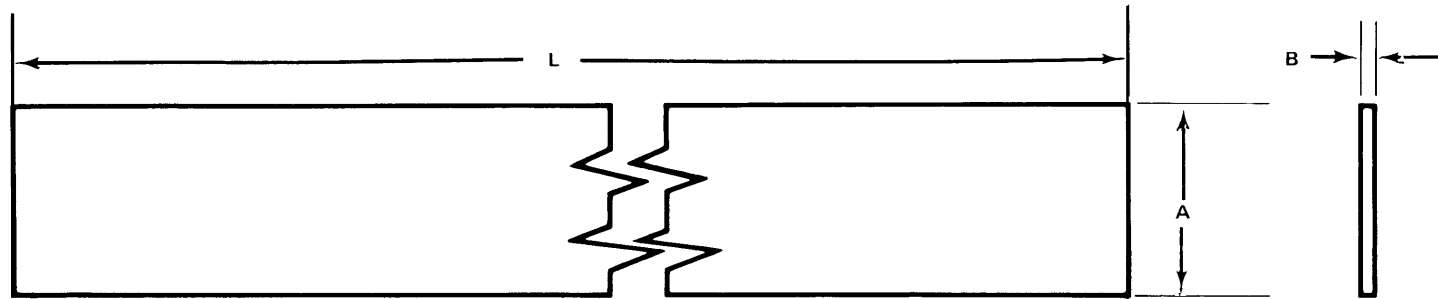
Figure D-169. Part Number 205-060-802-11 HINGE  
 Fabricate from: NSN 5340-00-687-7586  
 Part Number 205-060-802-13 FITTING  
 Fabricate from: NSN 5340-00-947-9874



**Figure D-170.** Part Number 205-060-810-15  
 205-060-810-16 DOOR ASSEMBLY  
 Fabricate from: NSN 5340-00-701-9897  
 NSN 5340-00-993-1461  
 NSN 9535-00-232-0378  
 Material: Leaf, Butt, Hinge, Aluminum - Make from MS20257HP2-7200 Material  
 2024 AL ALY Sheet, Federal Specification QQ-A-250/5, 0.064 Inch Thick



**Figure D-171.** Part Number 205-060-826-81, SEAL  
Fabricate from: NSN 5330-00-754-7443  
Material: Extrusion, Rubber, Federal Specification MIL-R-5847, Class I



PART NUMBER	ITEM NAME	FABRICATE FROM NSN	A	B	L
205-060-826-83	GASKET	9320-00-241-9754	0.500	0.062	46.00
205-060-826-85	GASKET	5330-00-938-1719	0.700	0.046	47.00
205-061-520-13	PAD	5330-00-530-1858	1.250	0.120	AR

Figure D-172. Part Number 205-060-826-83 GASKET  
205-060-826-85



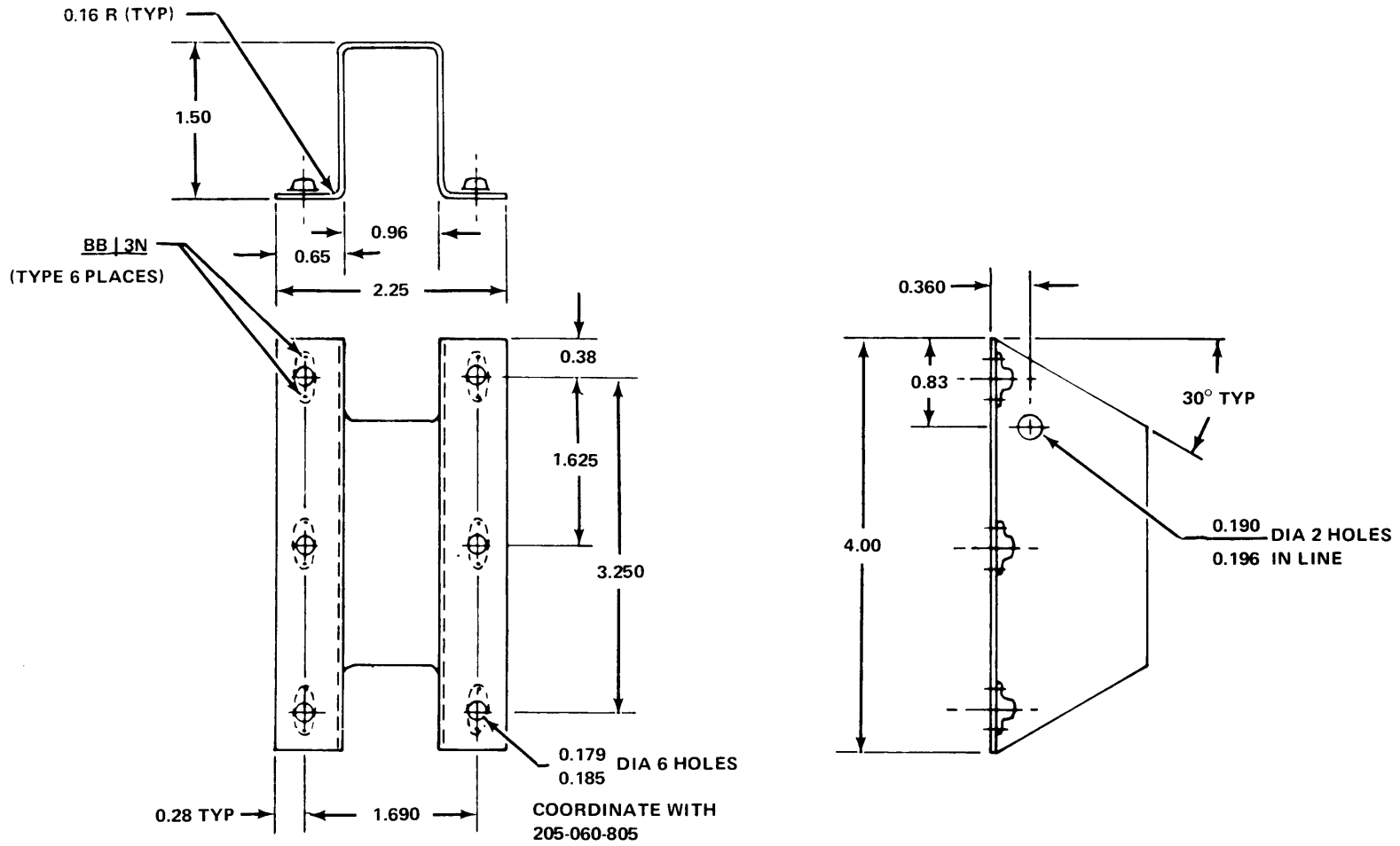


Figure D-173. Part Number  
Fabricate from:  
Material:

205-060-838-1 SUPPORT ASSEMBLY  
NSN 9535-00-167-2280  
NSN 5310-00-584-7339  
2024 AL ALY Sheet, Federal Specification QQ-A-362,  
T3, 0.040 Inch Thick

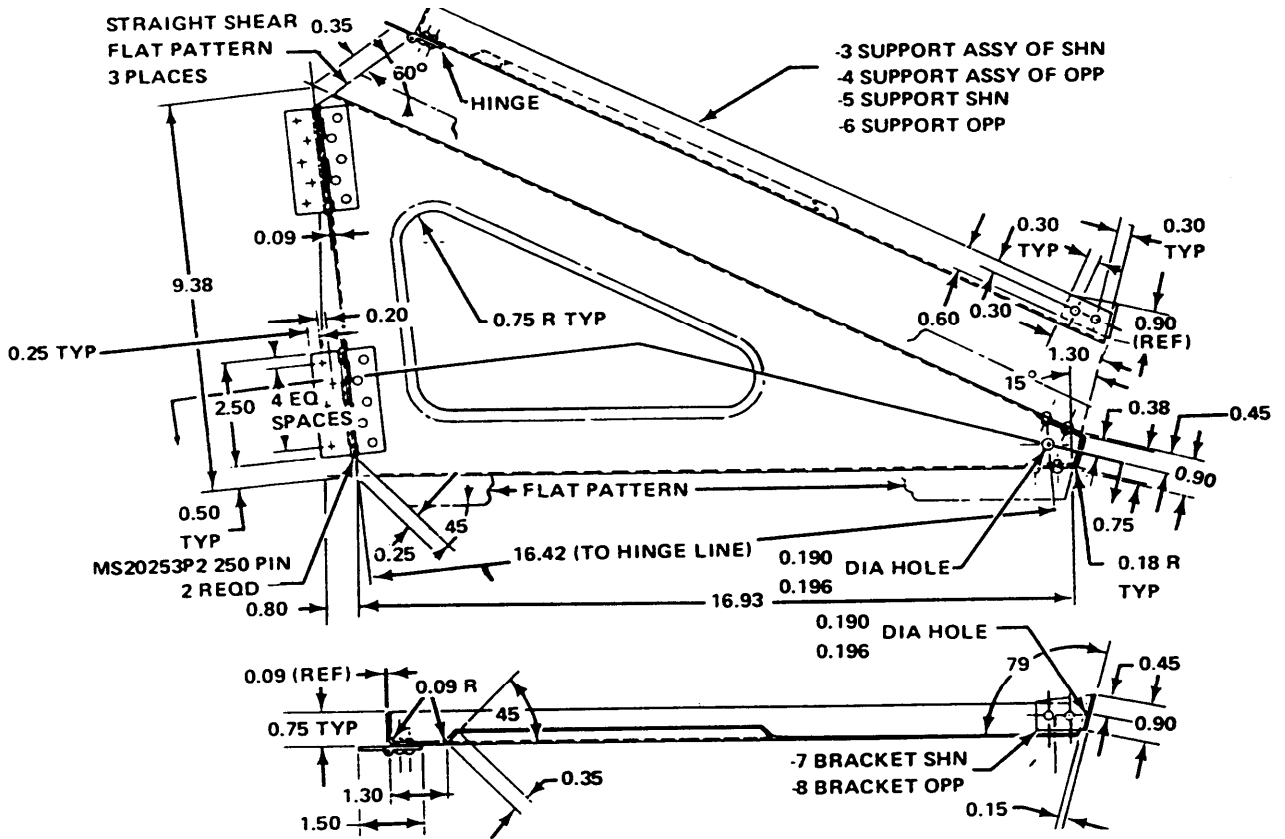


Figure D-174. Part Number: 205-060-860-3 SUPPORT ASSEMBLY, Shown  
 SUPPORT, Shown, NSN 9535-00-086-9729  
 BRACKET, Shown, NSN 9535-00-640-2311  
 HINGE HALF, NSN 5340-00-838-2787  
 HINGE PIN, NSN 5340-00-543-3723

Part Number: 205-060-860-4 SUPPORT ASSEMBLY, Opposite  
 SUPPORT, Opposite, NSN 9535-00-086-9729  
 BRACKET, Opposite, NSN 9535-00-640-2311  
 HINGE HALF, NSN 5340-00-838-2787  
 HINGE PIN. NSN 5340-00-543-3723

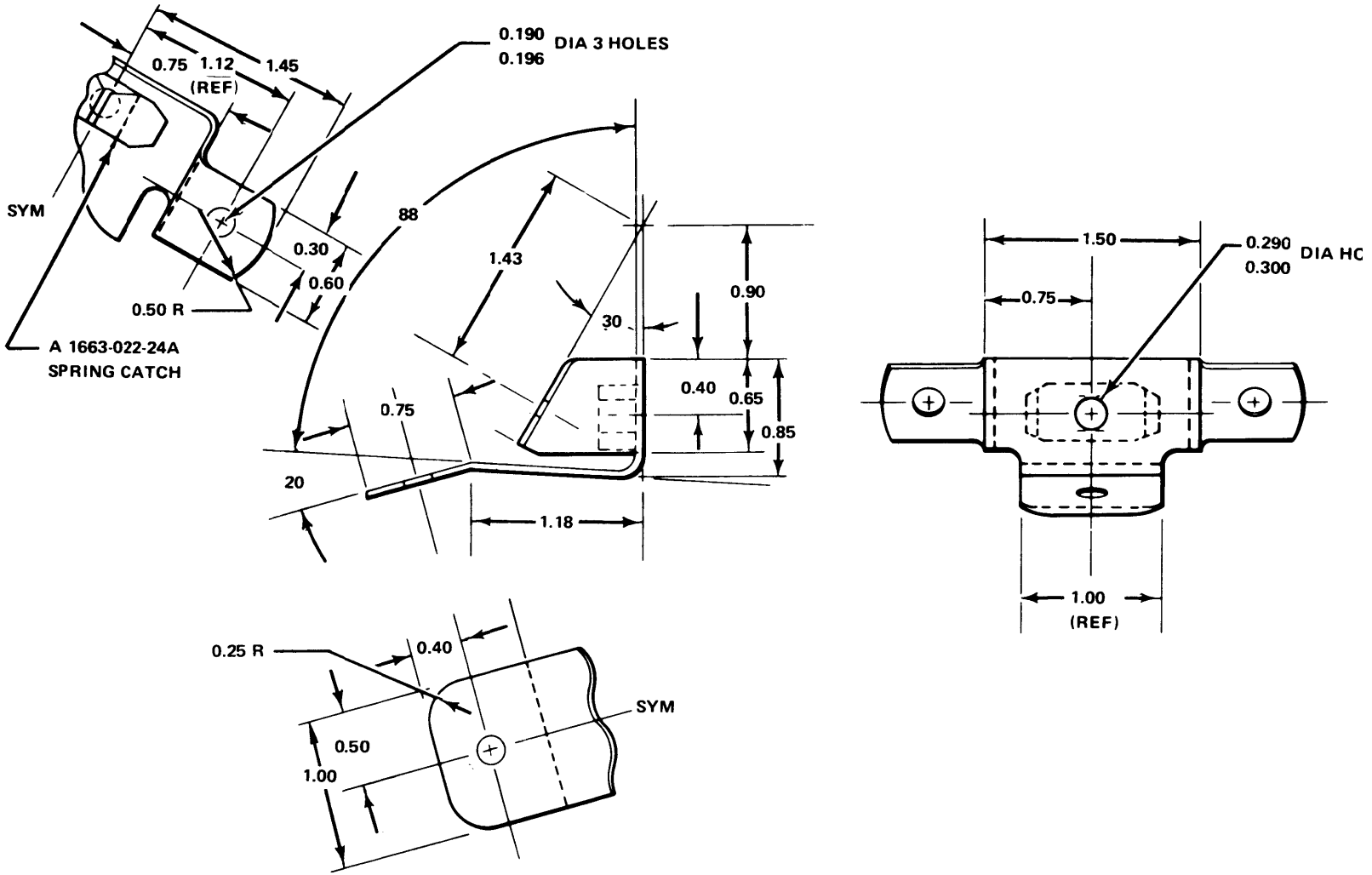


Figure D-175.

Figure D-175. Part Number  
Fabricate from:

Material:

**205-060-862-1 BRACKET ASSEMBLY**  
**BRACKET, NSN 9535-00-640-2311**  
**SPRING CATCH, NSN 5340-00-634-7350**  
**2024 AL ALY Sheet, Federal Specification QQ-A-362,**  
**0.050 Inch Thick**  
**Receptacle, Friction Catch, A1663-022-24A**

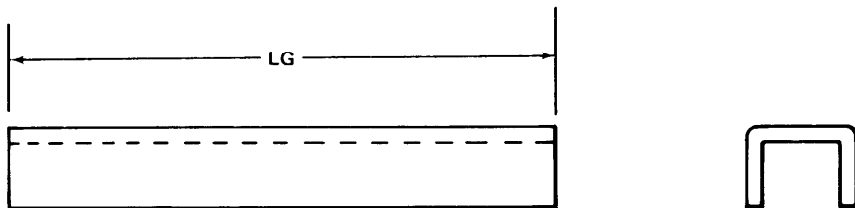


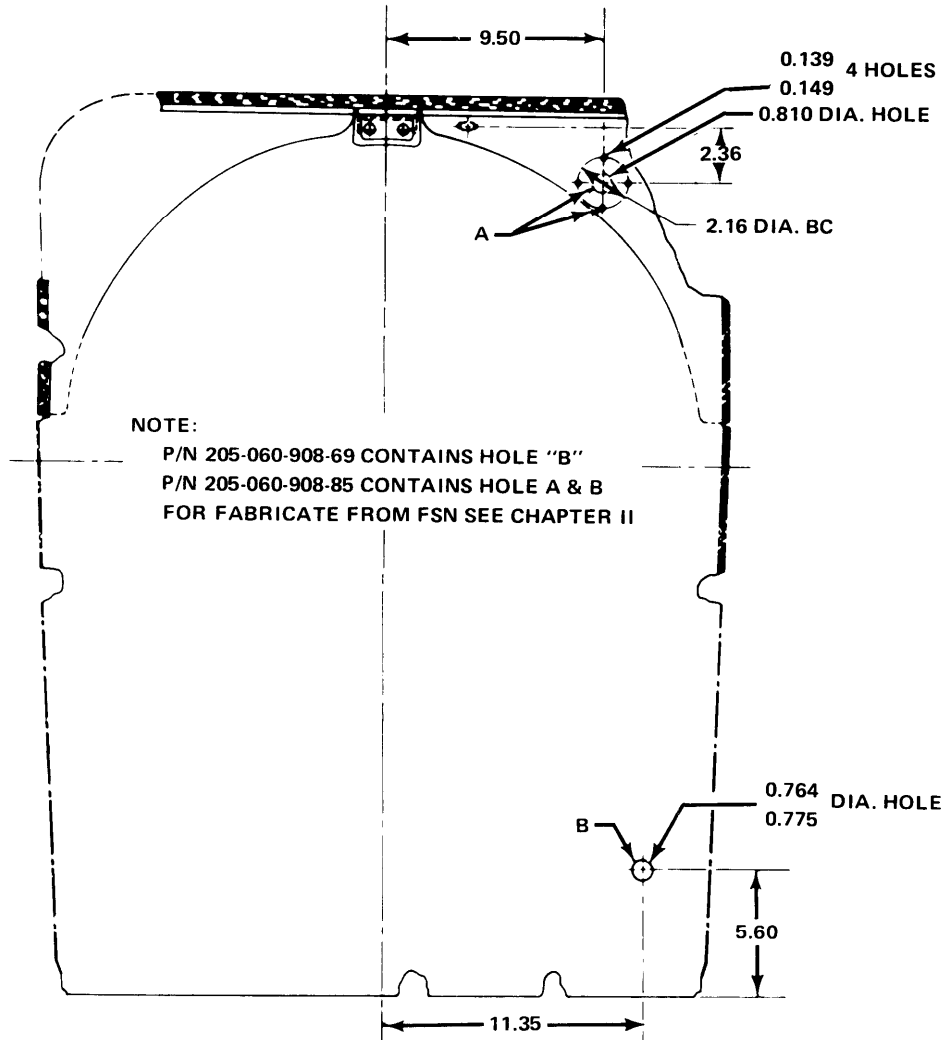
Figure D-176.

PART NUMBER	LENGTH
178036-3	AR
178038-3	AR
178040-3	AR
178042-3	AR
178044-3	AR
178050-3	AR
178050-5	AR
178050-7	AR
178052-3	AR
178052-5	AR
178052-7	AR

ITEM NAME CHANNEL
-------------------

Fabricate from: NSN 9320-00-107-4517  
 Material: Channel, Etrusion



**Figure D-177.** Part Numbers 205-060-908-79 & -85 FIRE WALL ASSY'S  
 Fabricate from: NSN 1560-00-758-0299  
 P/N 205-060-908-73

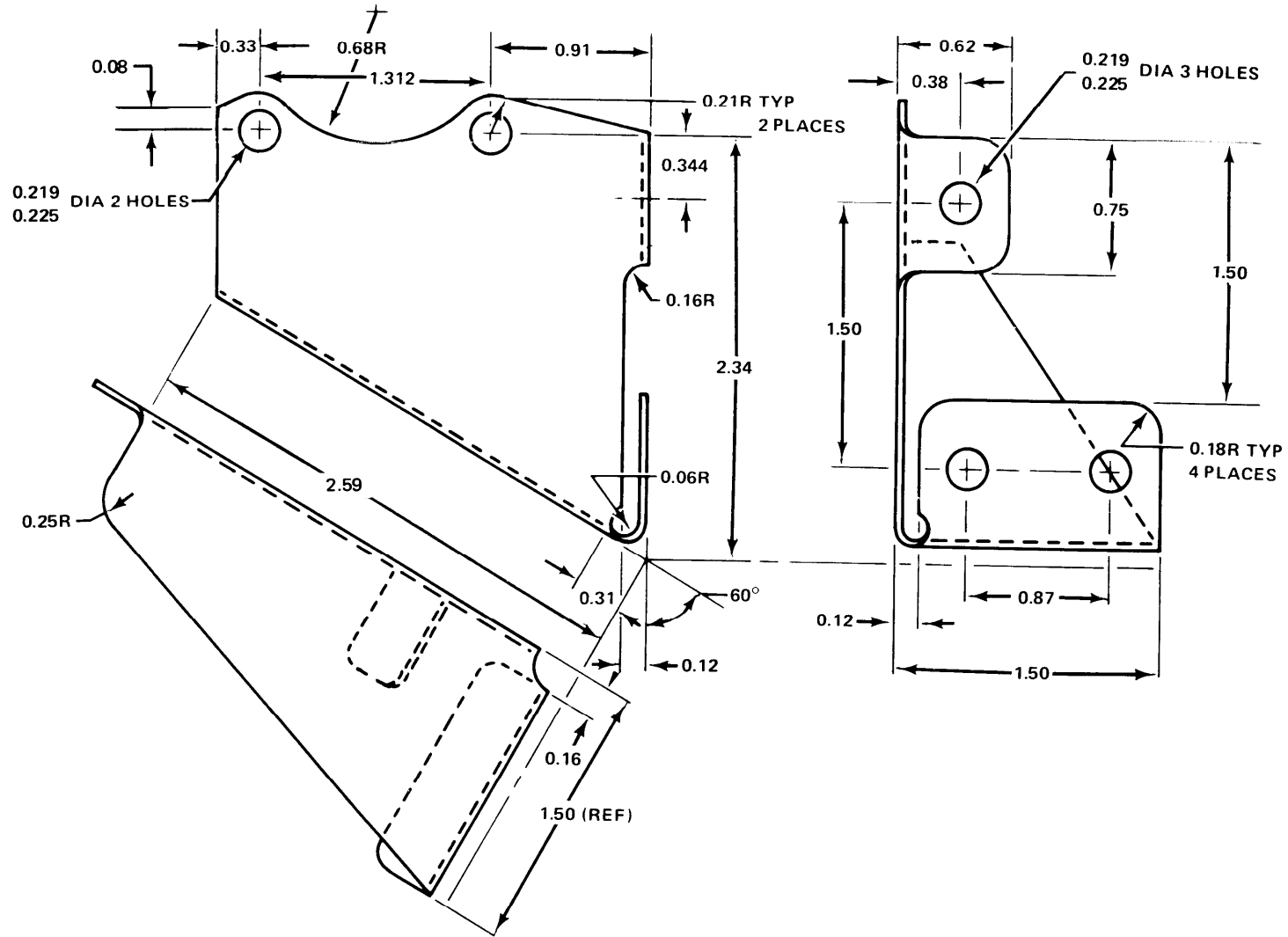


Figure D-178. Part Number: 205-060-919-3 BRACKET, Fuel System Valve  
 Fabricate from: NSN 9535-00-167-2278  
 Material: 2024 AL ALY Sheet, Federal Specification QQ-A-362,  
 0.025 Inch Thick

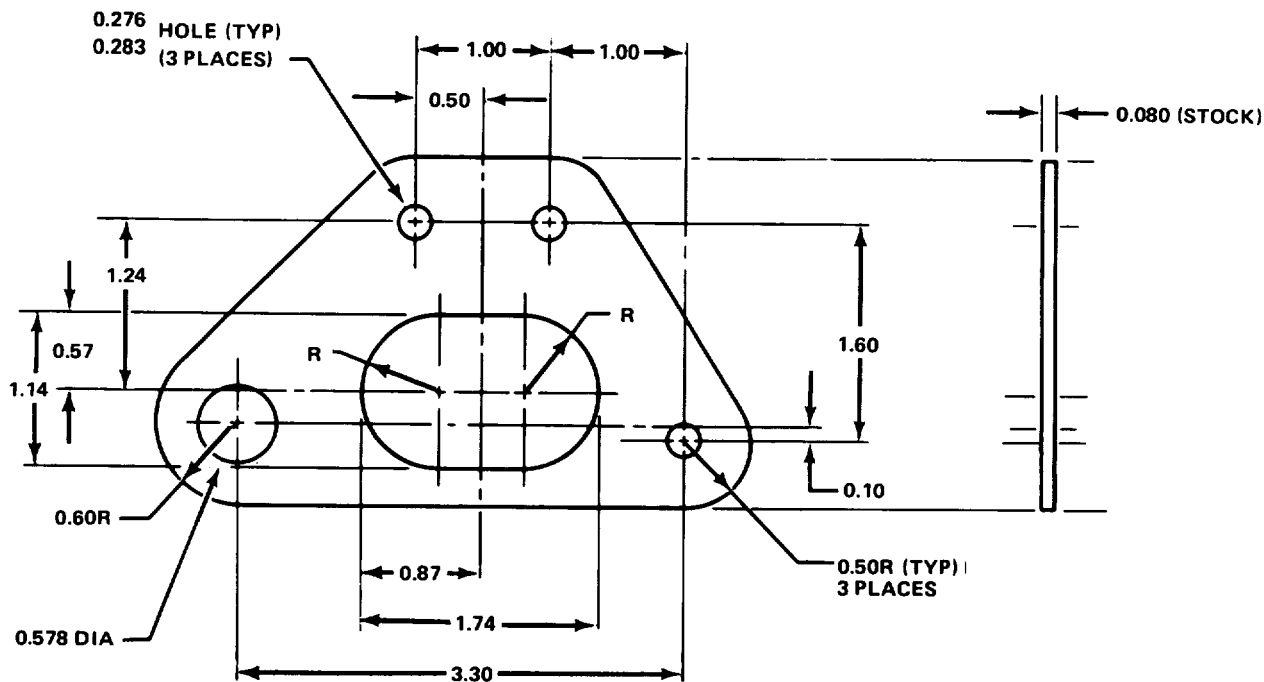


Figure D-179. Part Number 205-061-643-1, PLATE, Baffle, Fuel Cell  
 Fabricate from: NSN 9535-00-167-2247  
 Material: 2024 AL ALY Sheet, Federal Specification QQ-A-250/4, 0.250 Inch Thick

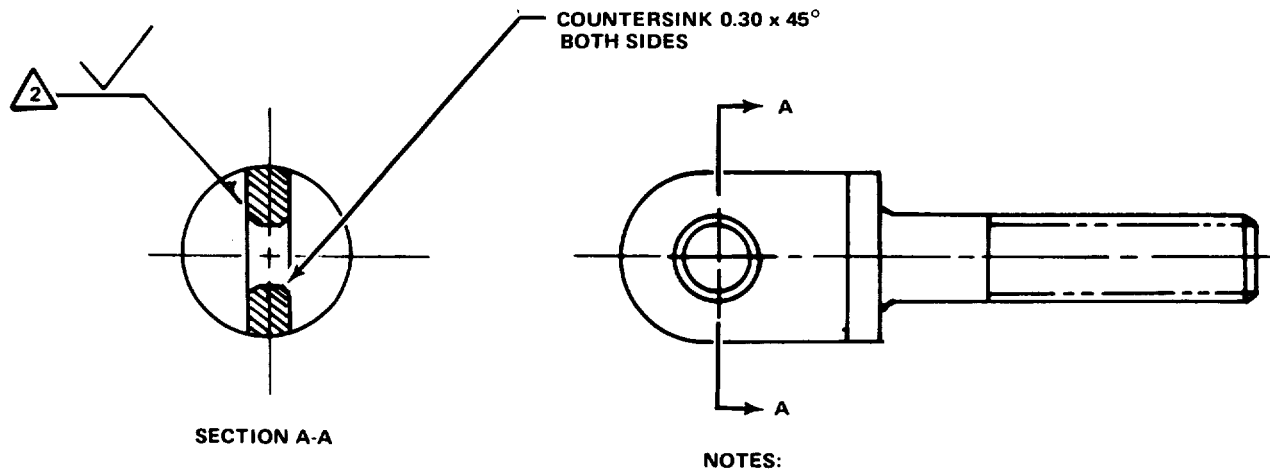
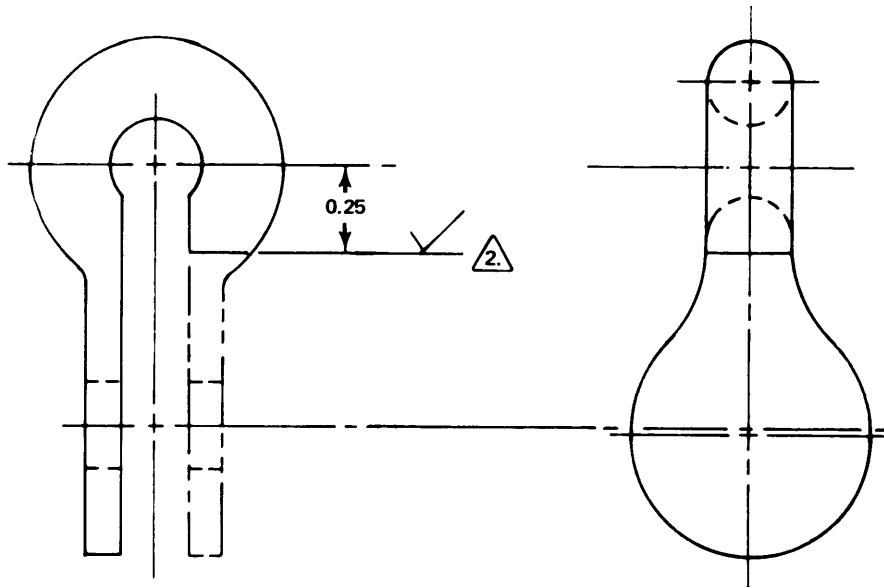


Figure D-180. Part Number 205-061-665-1 BOLT, Eye  
 Fabricate from: NSN 5306-00-260-7578  
 Material: Cadmium Plated Finish Class II Type I

NOTES:  
 2 BREAK SHARP EDGES IN MACHINES AREA 0.10R OR CHAMFER  
 ALTERED FROM GOVERNMENT STANDARD PART NUMBER AN43B-5A.



NOTES:



BREAK SHARP EDGES IN MACHINED AREA 0.010 R OR CHAMFER  
AN 115-32 MAY BE USED AS AN ALTERNATE FOR MS 20115 F5

Figure D-181. Part Number 205-061-666-1 HOOK  
Fabricate from: NSN 4030-00-852-6408  
Material:

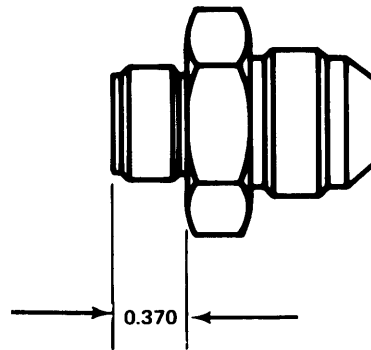
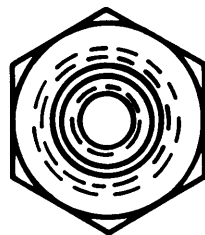
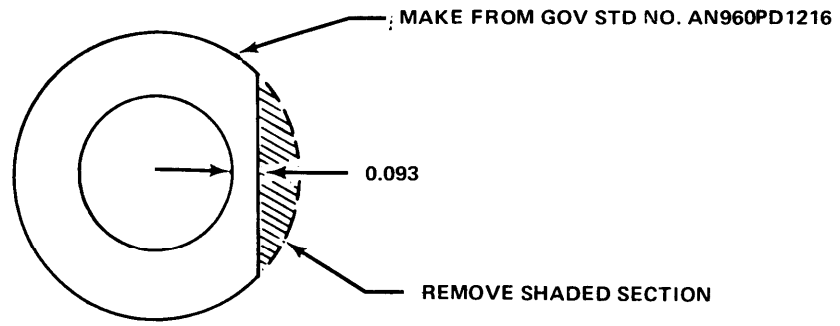
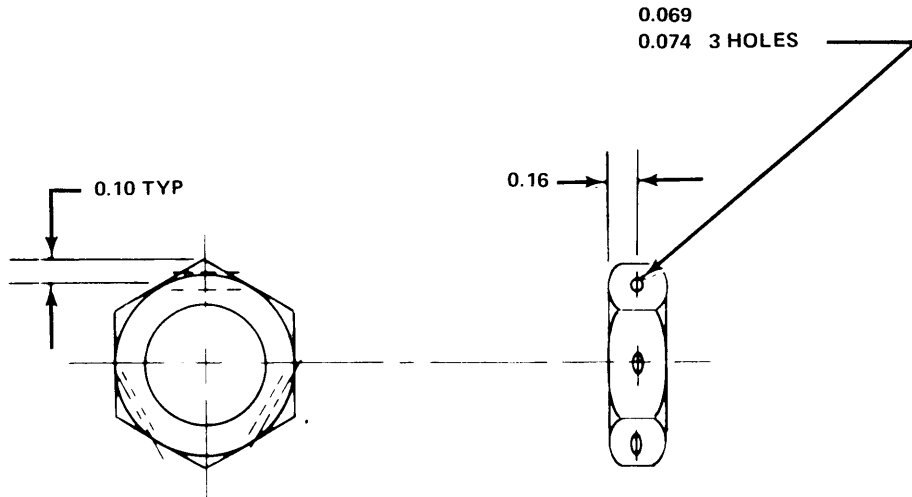


Figure D-182. Part Number 205-061-672-1 REDUCER, Fuel Pump Air Inlet  
Fabricate from: NSN 4730-00-803-7981  
Material:





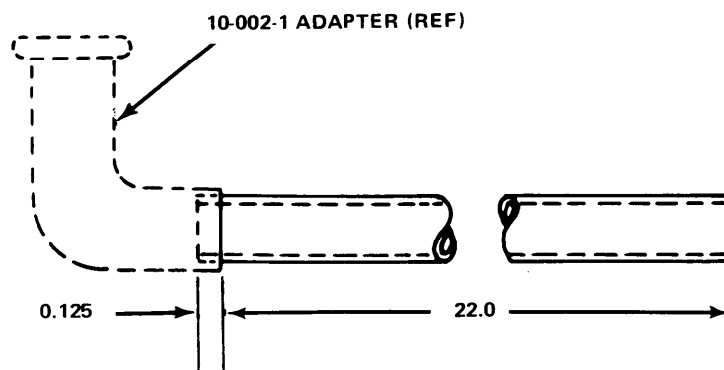
**Figure D-183.** Part Number 205-061-677-1 WASHER, Bleed Air  
 Fabricate from: NSN 5310-00-187-2404  
 Material:



NOTES:

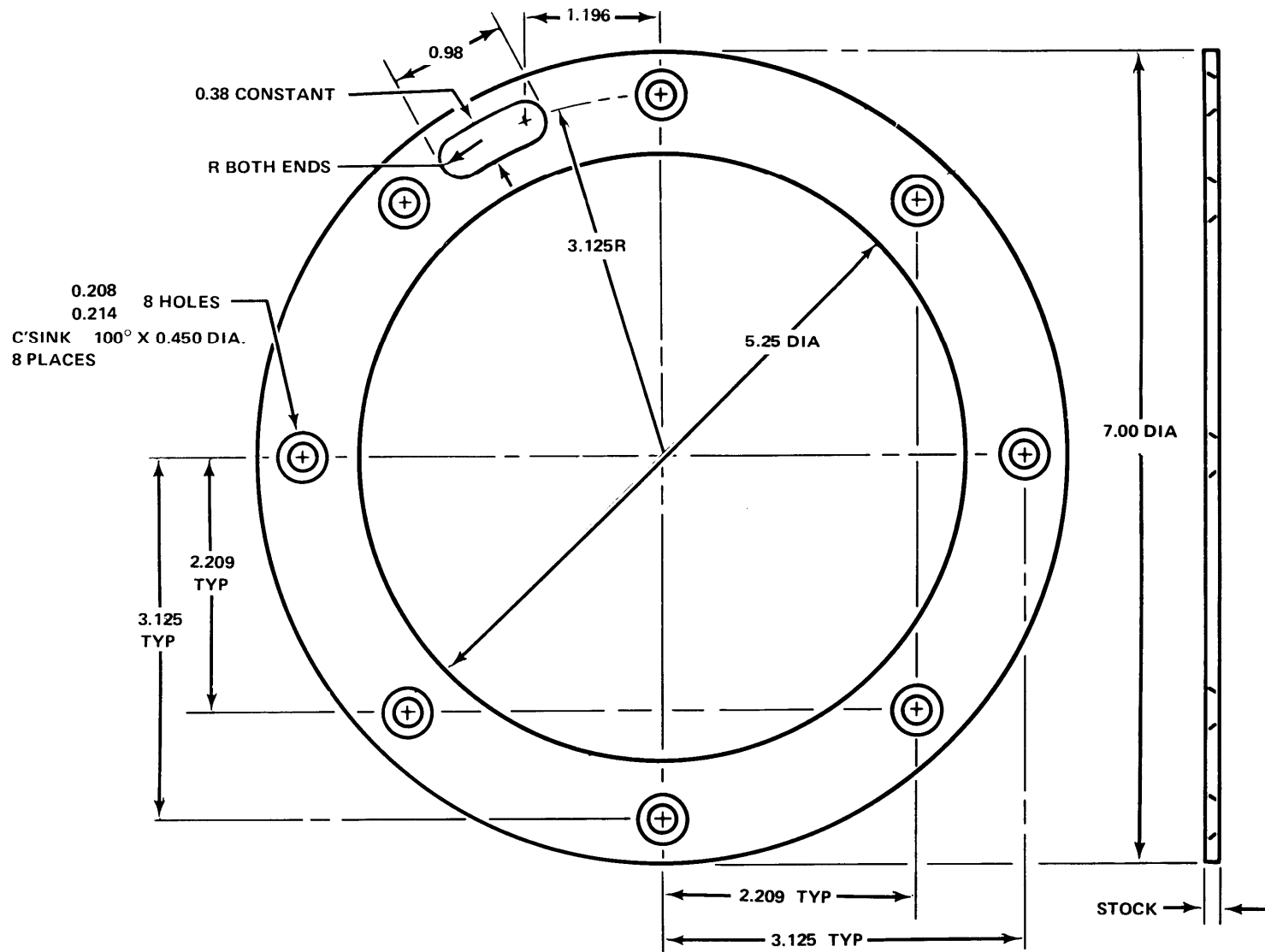
ALTERED FROM GOVERNMENT  
 STANDARD PART NO. AN924-8D

**Figure D-184.** Part Number 205-061-684-1, NUT  
 Fabricate from: NSN 5310-00-282-7835  
 Material:



**NOTE:**  
1. BOND WITH ADHESIVE

**Figure D-185.** Part Number 205-075-142-11 TUBE, BATTERY VENT  
Fabricate from: NSN 4720-00-246-4355  
Material:



**Figure D-186.** Part Number 205-070-404-1, SPACER, Spot Heating Connector  
 Fabricate from: NSN 9535-00-232-0378  
 Material: 2024 AL ALY Sheet, Federal Specification QQ-A-250/5, 0.063 Inch Thick

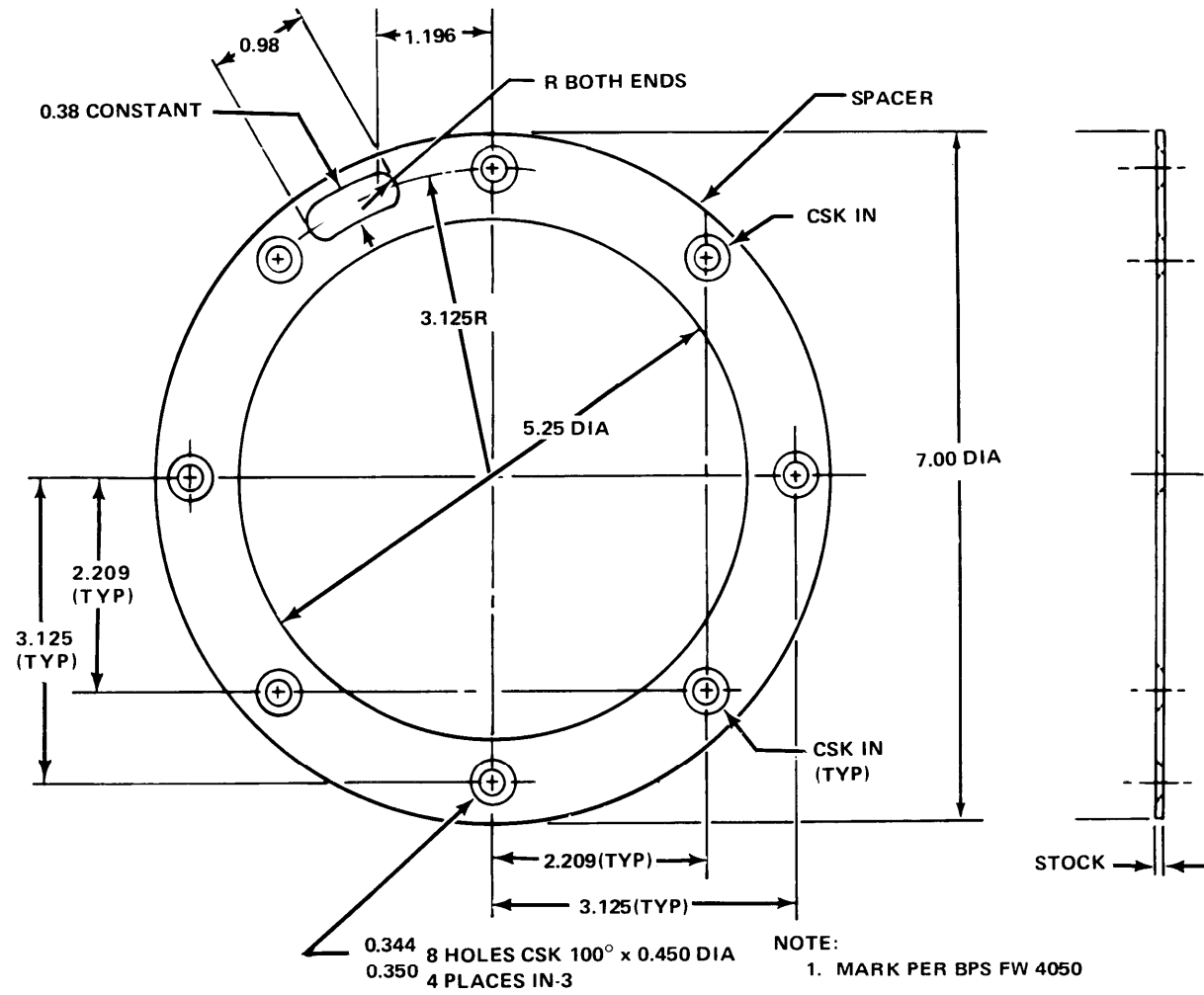
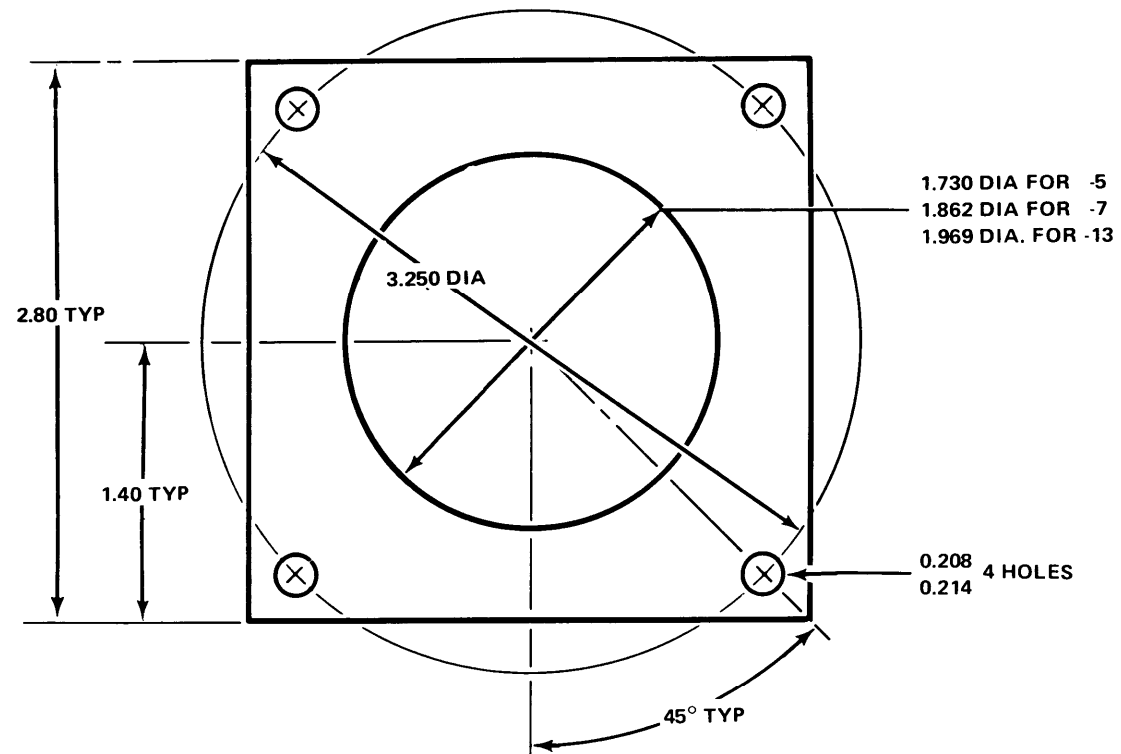
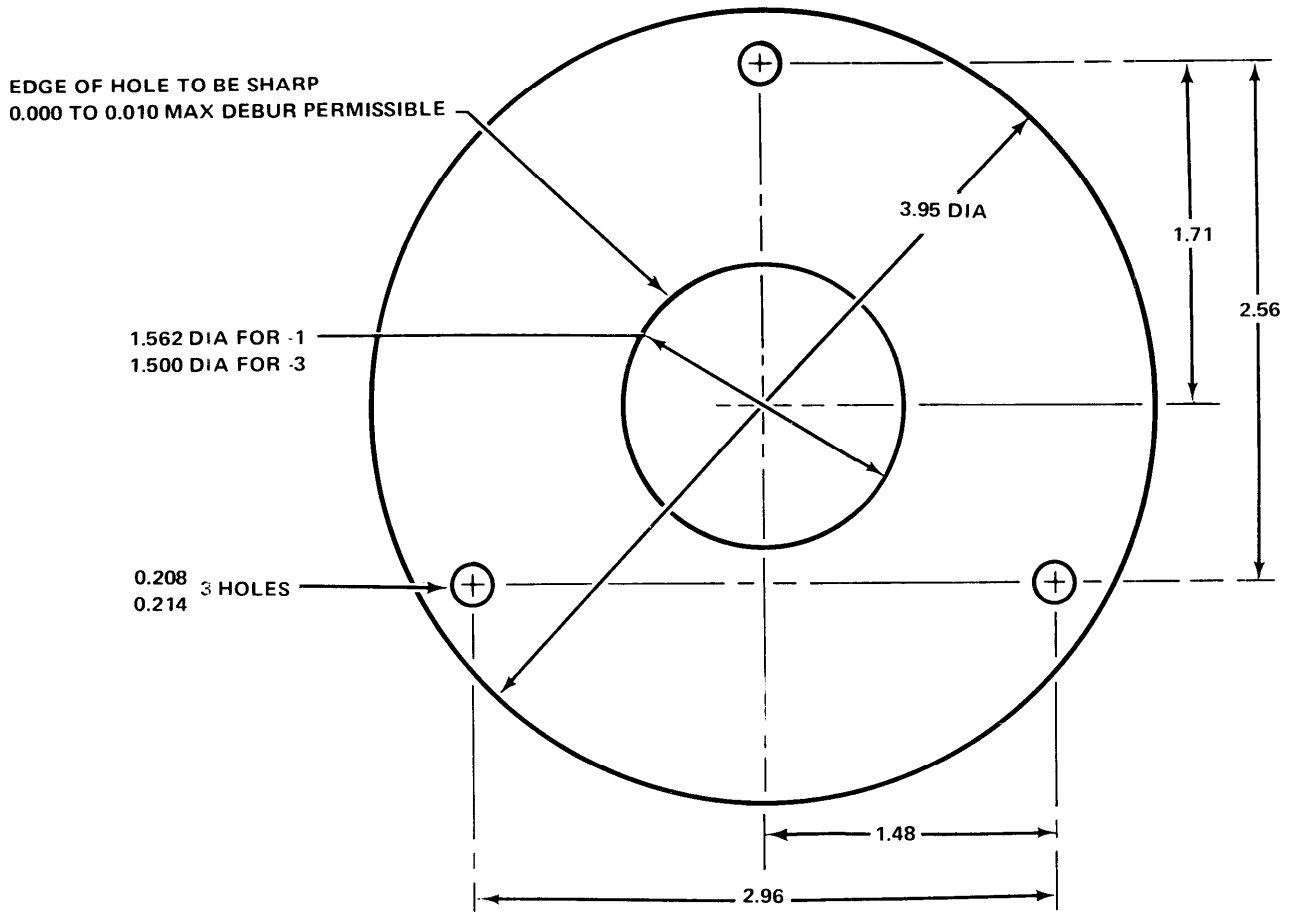


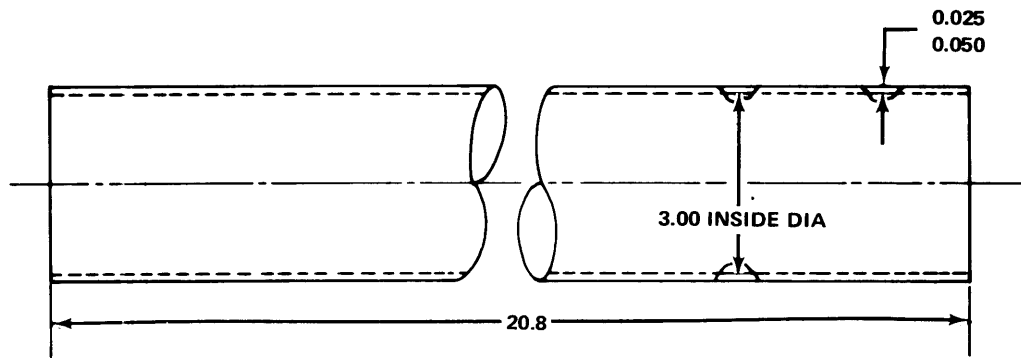
Figure D-187. Part Number 205-070-404-3, SPACER  
 Fabricate from: NSN 9535-00-232-0378  
 Material: 2024 AL ALY Sheet, Federal Specification QQ-A-250/5, 0.063 Inch Thick



**Figure D-188.** Part Number 205-070-416-5, 205-070-416-7 and 205-070-416-13  
 ORIFICE PLATE, Air Distribution Outlet  
 Fabricate from: NSN 9535-00-167-2279  
 Material: 2024 AL ALY Sheet, Federal Specification QQ-A-250/5, 0.032 Inch Thick



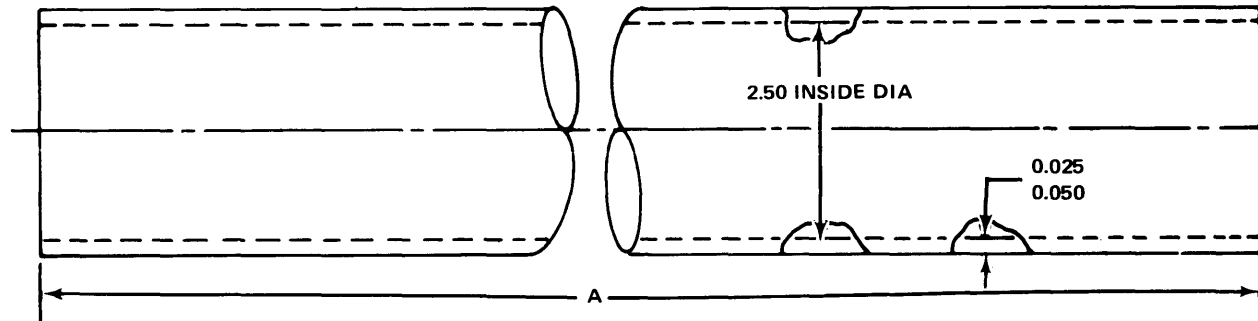
**Figure D-189.** Part Number 205-070-430-1 and 205-070-430-3, ORIFICE,  
Air Distribution Defrost Nozzle  
Fabricate from: NSN 9535-00-167-2279  
Material: 2024 AL ALY Sheet, Federal Specification QQ-A-250/5, 0.032 Inch Thick



**NOTES:**

1. DUCT MAY BE MADE FROM MAT'L THICKNESS BEST SUITED TO MFG. METHOD
2. COLOR MAY BE MADE:
  - A. OF TWO OR MORE PARTS JOINED TOGETHER WITH ETHYLENE DICHLORIDE OR AIR WELDED
  - B. WITH JOINT PROJECTIONS (BEAD OR FLANGE) NOT TO EXCEED 0.12 HIGH OR WIDE ON THE EXTERNAL SURFACE AND TO BE FLUSH 1.20 FROM ENDS
3. DUCT TO BE AN AIRTIGHT ENCLOSURE AT 15 IN. H<sub>2</sub>O GAGE AND ROOM CONDITIONS.

**Figure D-190.** Part Number 205-070-450-3 HOSE, Air Duct  
Fabricate from: NSN 4720-00-736-0985  
Material: Hose Air Duct, Fiberglass Cloth 2.5 Inch ID



DASH NO.	DIM. A
-1	7.06
-3	18.75

**NOTES:**

1. DUCT MAY BE MADE FROM MAT'L THICKNESS BEST SUITED TO MFR. METHOD
2. COLOR OF DUCT TO BE GRAY PER MATERIAL BULLETIN FW 1270
3. DUCT MAY BE MADE:
  - A. OF TWO OR MORE PARTS JOINED TOGETHER WITH ETHYLENE DICHLORIDE OR AIR WELDED
  - B. WITH JOINT PROJECTIONS (BEAD OR FLANGE) NOT TO EXCEED 0.12 HIGH OR WIDE ON THE EXTERNAL SURFACE AND TO BE FLUSH 1.20 FROM ENDS
4. DUCT TO BE AN AIR TIGHT ENCLOSURE AT 15 IN. H<sub>2</sub>O GAGE AND ROOM CONDITIONS

**Figure D-191. Part Numbers**

205-070-452-1, HOSE AIR DUCT

205-070-452-3

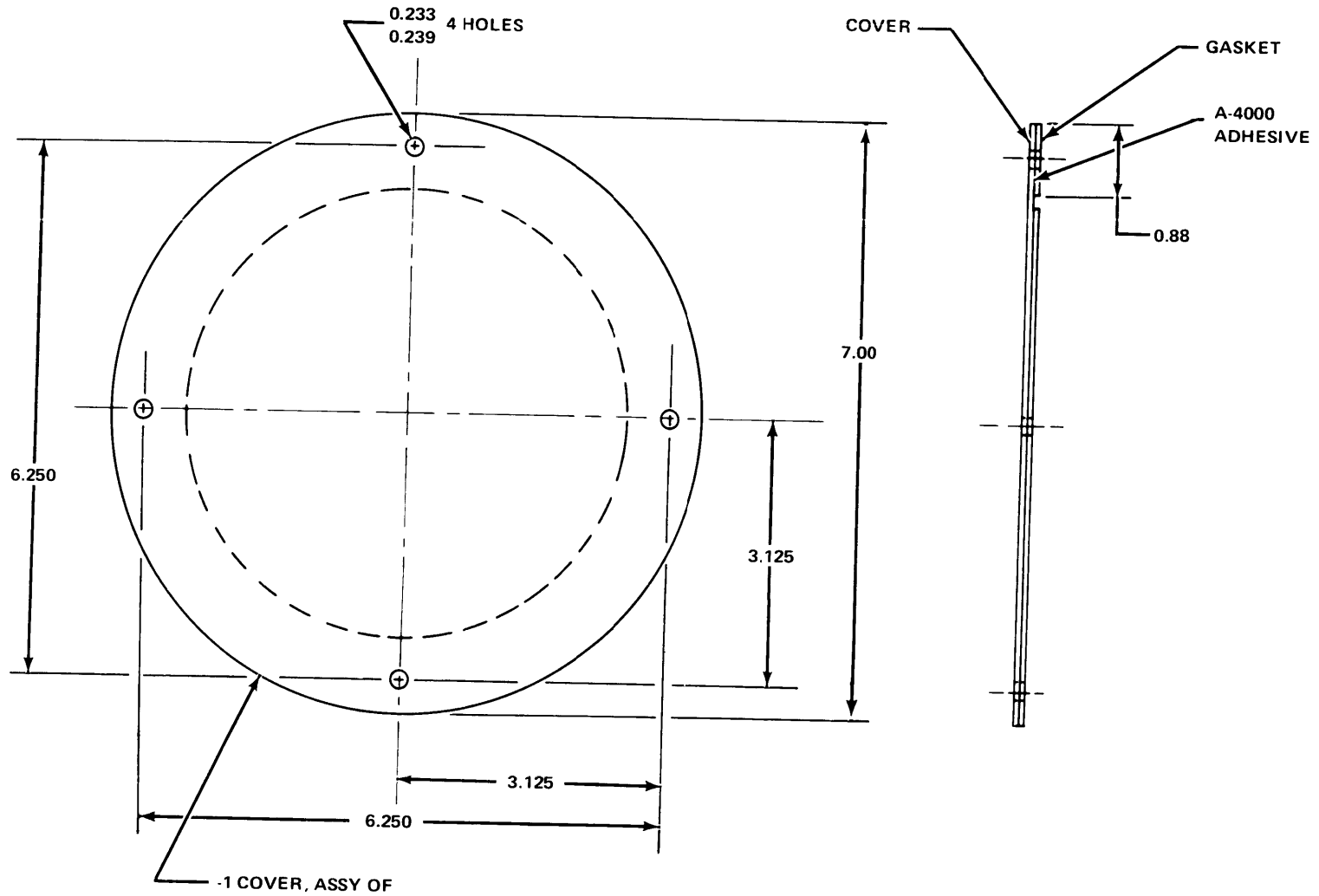
**Fabricate from:**

NSN 4720-00-736-0985

**Material:**

Hose Air Duct, Fiberglass Cloth 2.5 Inch ID

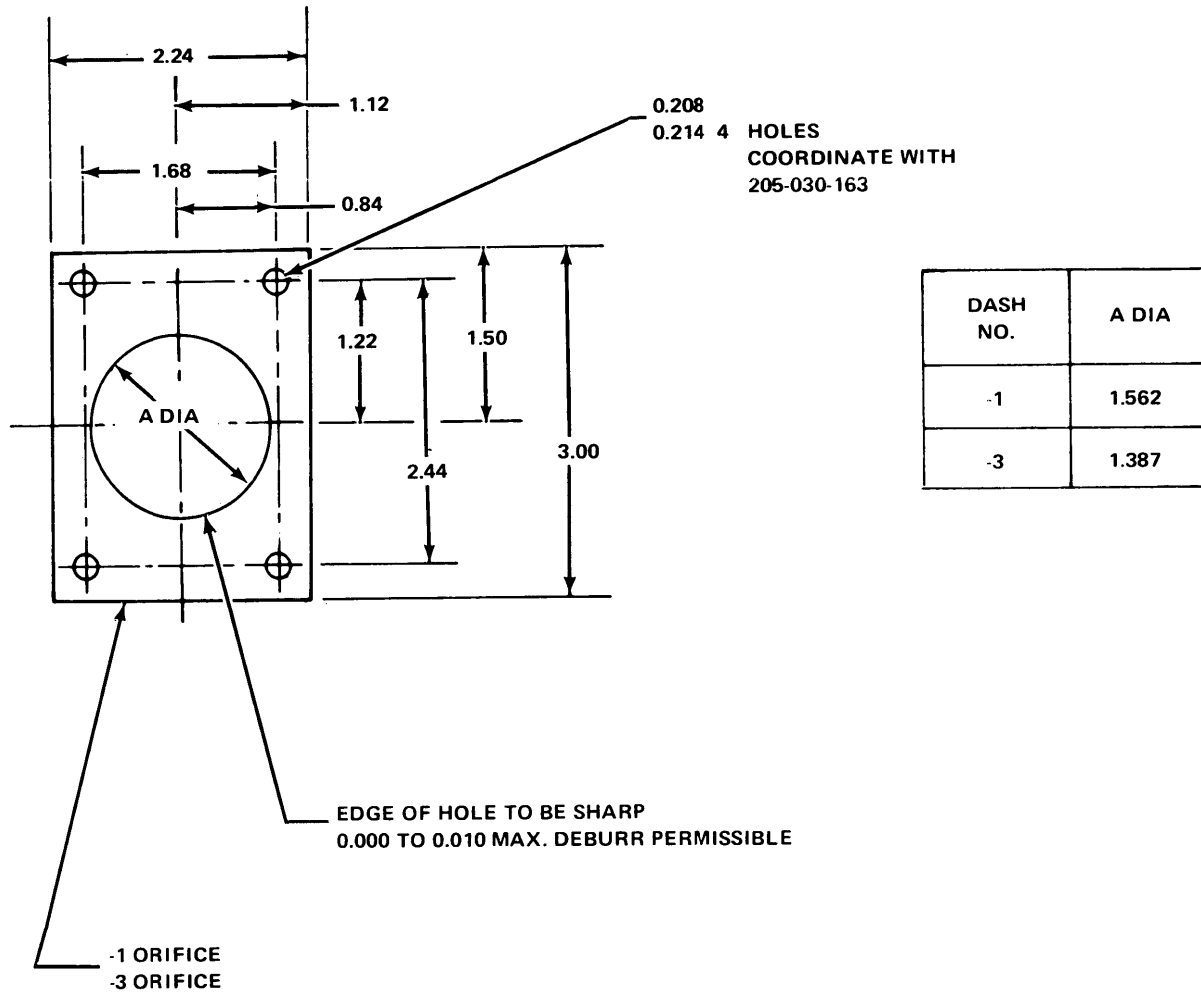




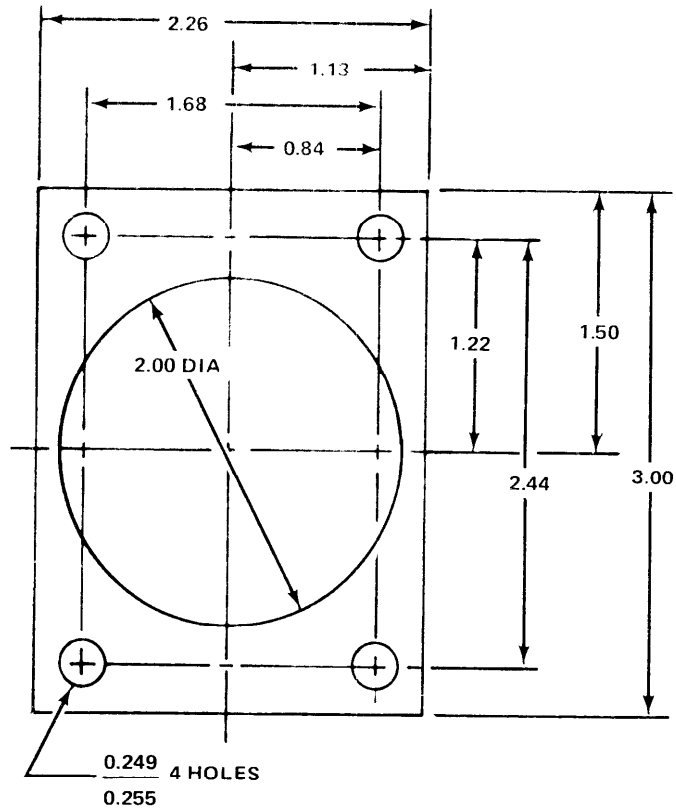
**Figure D-192. Part Number**  
**Fabricate from:**  
**Material:**

**205-070-483-1 COVER ASSEMBLY, Inlet**  
**NSN 9535-00-106-0609**  
**NSN 9320-00-061-1975**  
**Zinc Chromate Finish**

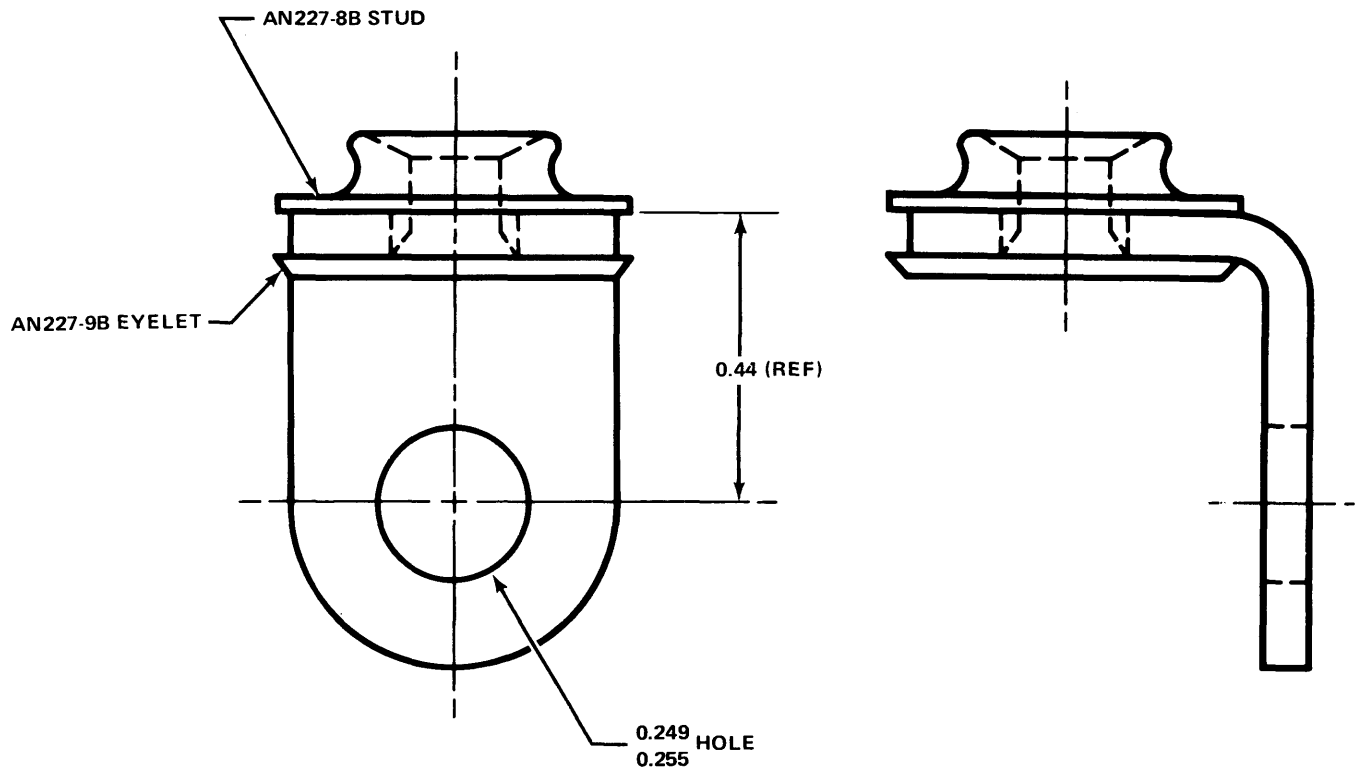
Figure D-193.



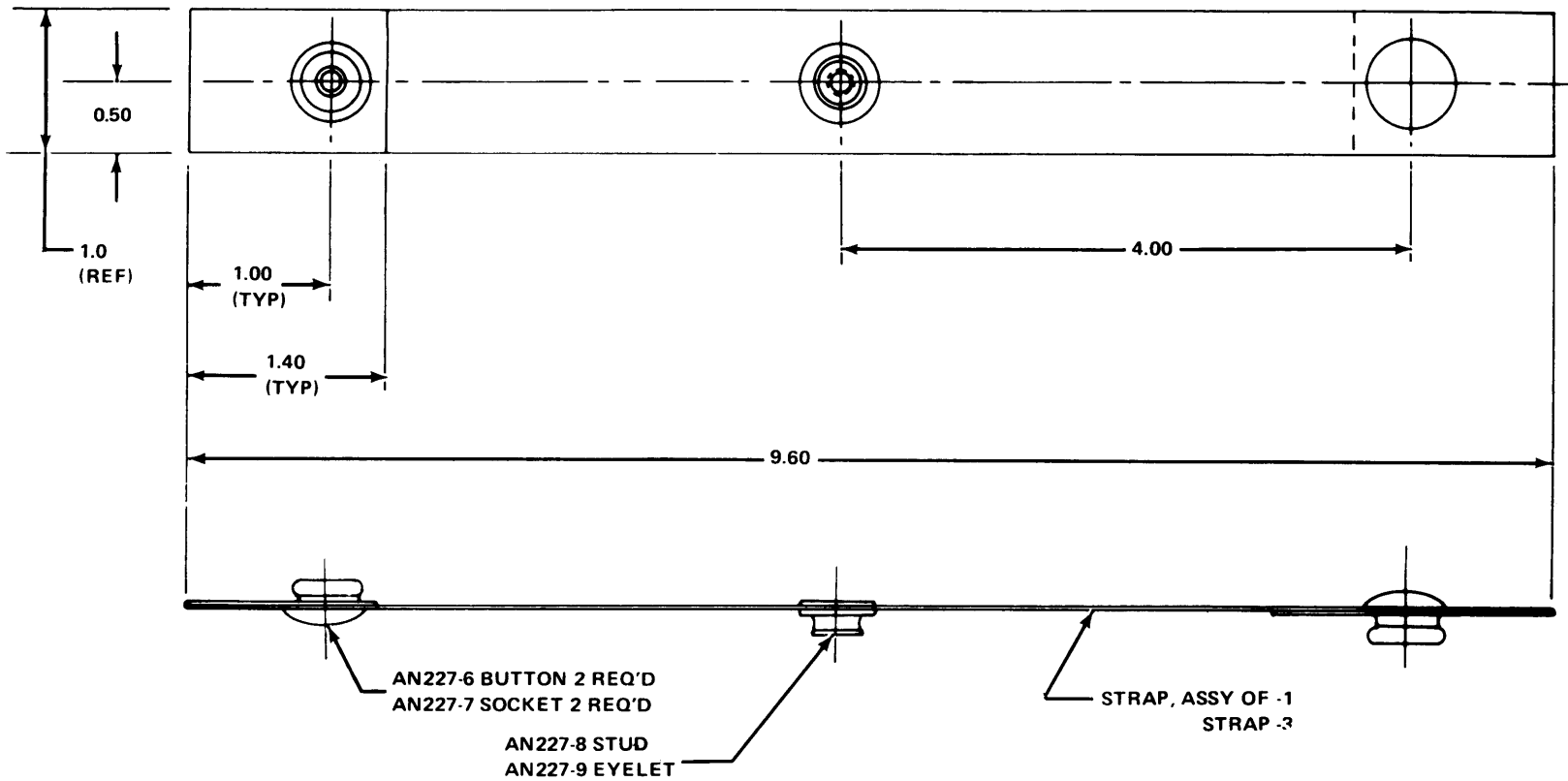
**Figure D-193. Part Numbers:** 205-070-493-1 ORIFICE, Foot Warmer  
204-070-493-3  
**Fabricate from:** NSN 9353-00-167-2279  
**Material:** 2024 AL ALY Sheet, Federal Specification  
QQ-A-250/5, 0.032 Inch Thick



**Figure D-194.** Part Number 205-070-494-1, GASKET  
 Fabricate from: NSN 5330-00-182-1288  
 Material: Cork and Rubber Sheet, Synthetic,  
 1/16 Inch Thick, Federal Specification  
 MIL-G-6183



**Figure D-195.** Part Number 205-070-609-1, SUPPORT ASSEMBLY, Blackout Curtain  
Fabricate from: NSN 9535-00-232-0378  
Material: 2024 AL ALY Sheet, Federal Specification QQ-A-250/5, 0.063 Inch Thick

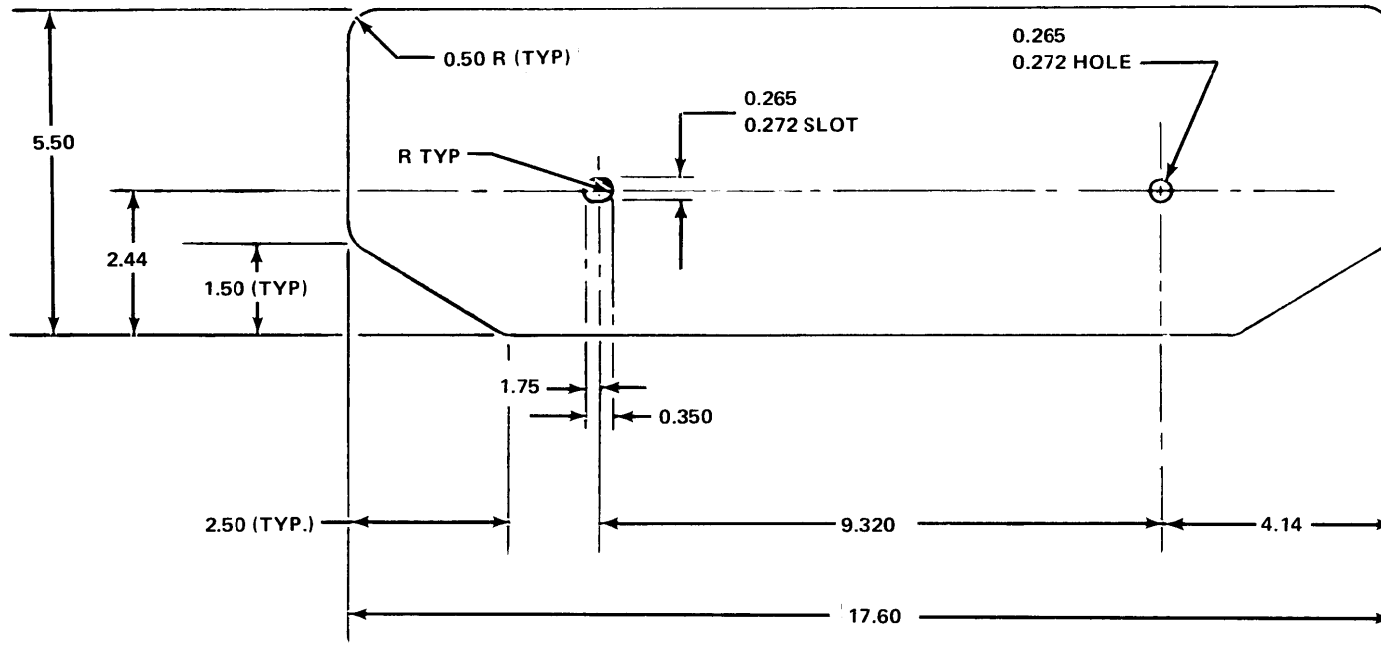


NOTES:

1. HEAT TREAT ENDS OF ALL WEBBING
2. COLOR LIGHT GULL GREY #36440  
PER FED STD 595

Figure D-196. Part Number  
Fabricate from:

205-070-656-1 STRAP ASSEMBLY  
 NSN 5325-00-276-4953  
 NSN 5325-00-276-4946  
 NSN 5325-00-174-2923  
 NSN 5325-00-276-4969  
 NSN 1680-00-225-5084  
 NSN 8305-00-260-6910



**Figure D-197.** Part Number 205-070-769-1 PLATE  
 Fabricate from: NSN 9535-00-167-2277  
 Material: 2024 AL ALY Sheet, Federal Specification  
 QQ-A-250/5, 0.020 Inch Thick

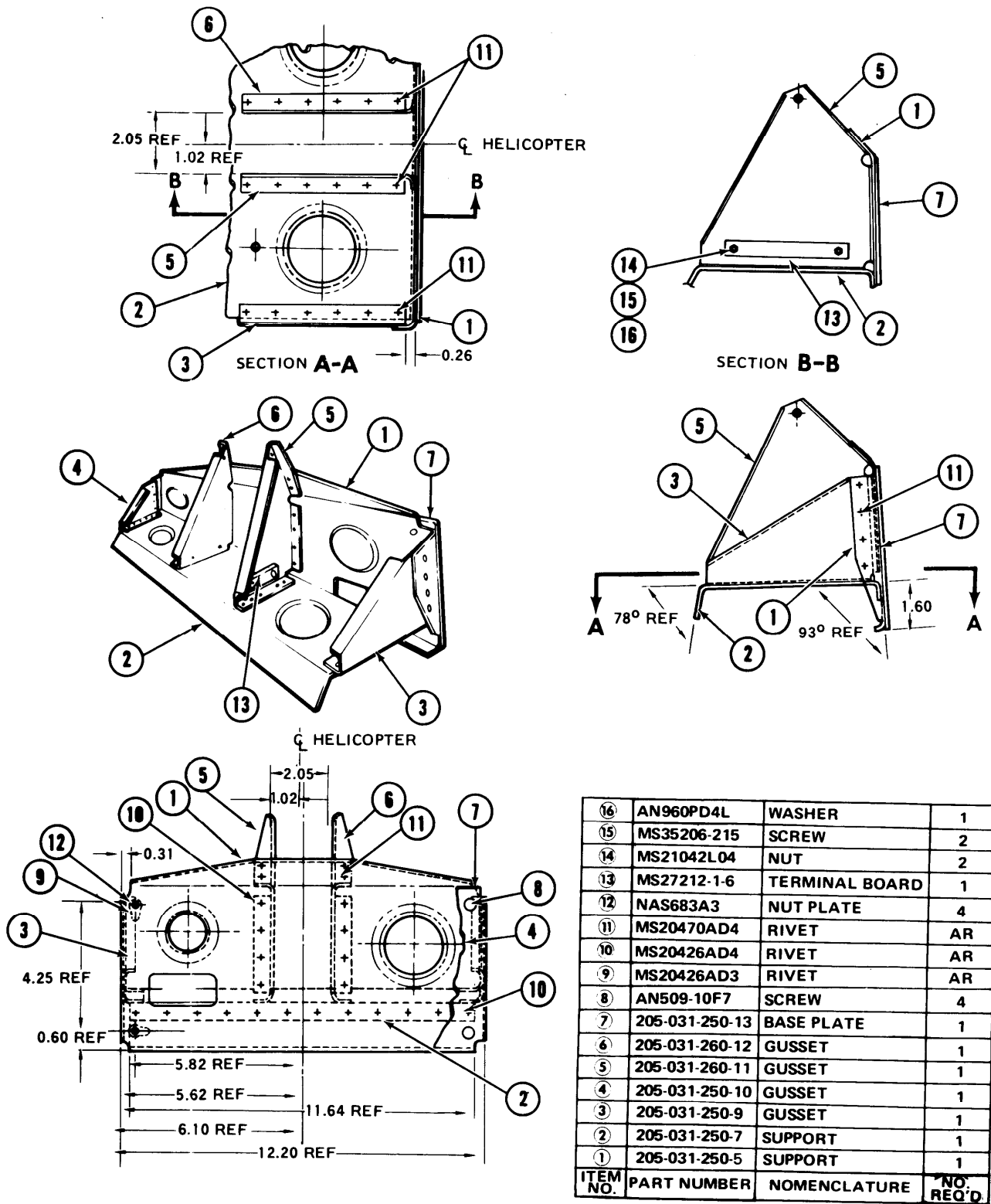
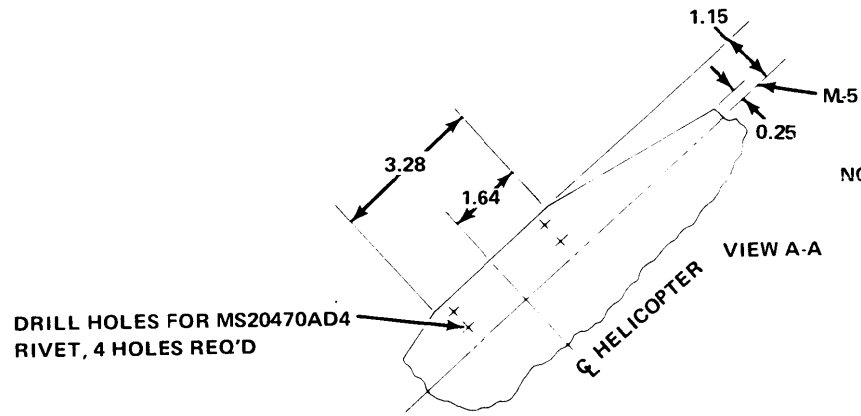


Figure D-198. Part Number 205-031-250-3 SUPPORT BRACKET ASSEMBLY  
(Sheet 1 of 6)



NOTES:

1. APPLY A CHEMICAL FILM NSN 8030-829-0376 PER TM 55-405-3 MANUAL
2. APPLY 1 COAT ZINC CHROMATE PRIMER NSN 8010-00-899-8825 PER TB 746-93-2, FOLLOWING APPLICATION OF CHEMICAL FILM
3. BEND RADII 0.18
4. DRILL RIVET HOLES AT TIME OF ASSEMBLY

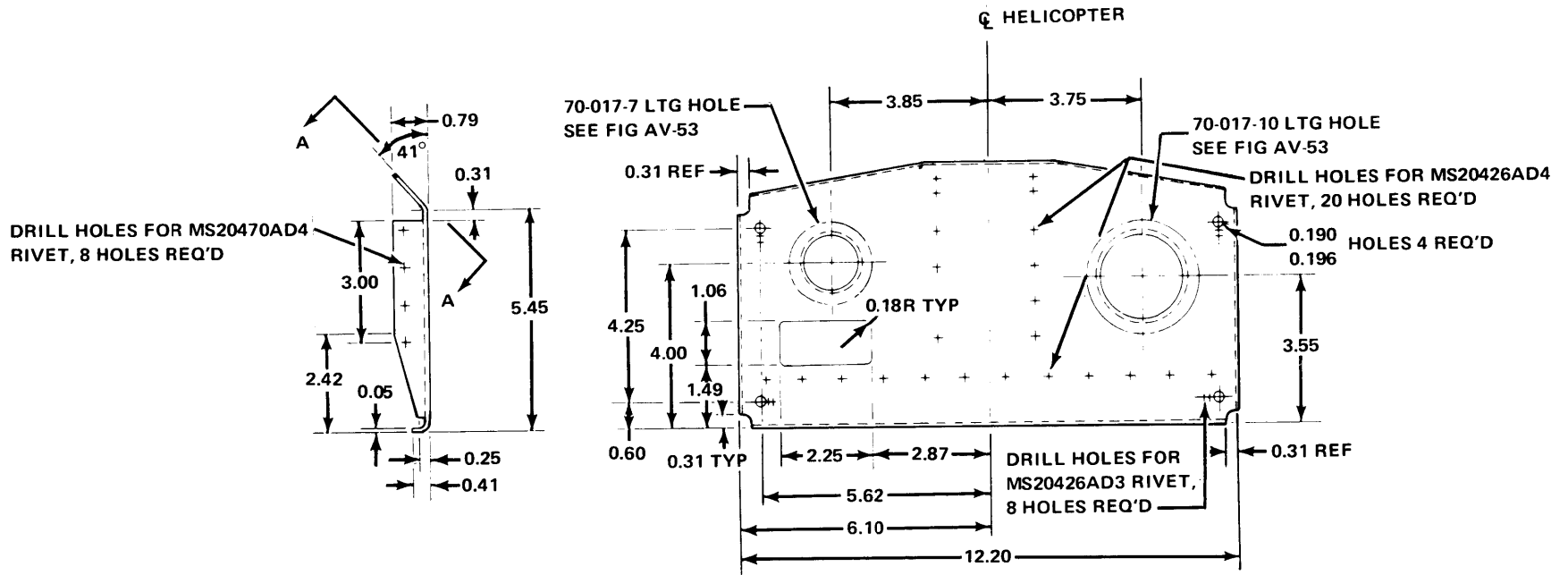


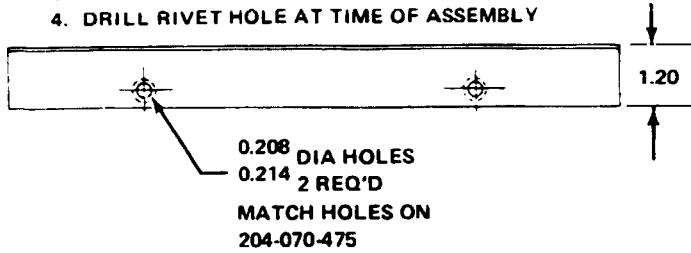
Figure D-198. Part Number  
(Sheet 2 of 6) Fabricate from:  
Material:

**205-031-250-5 SUPPORT**  
**NSN 9535-00-640-2311**  
**2024 AL ALY Sheet, Federal Specification QQ-A-250/5,**  
**TEMP T3, 0.050 Inch Thick**

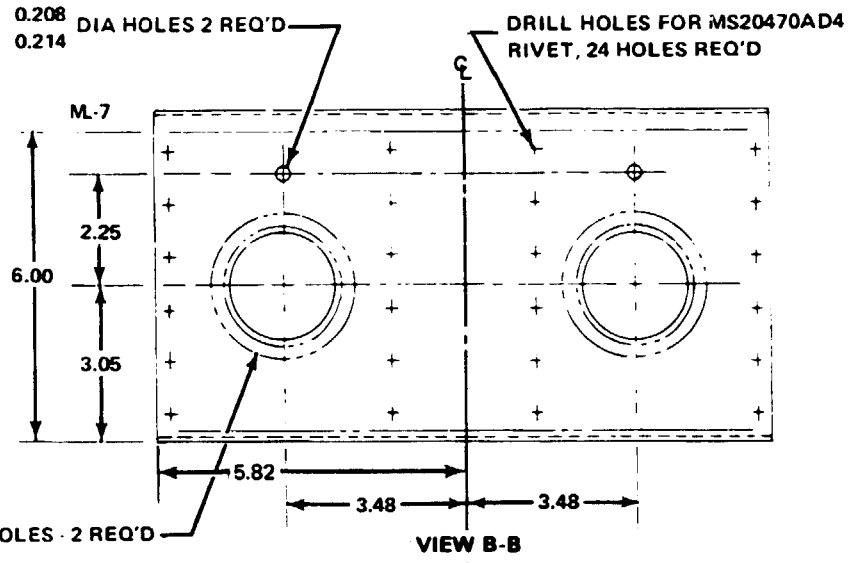


NOTES:

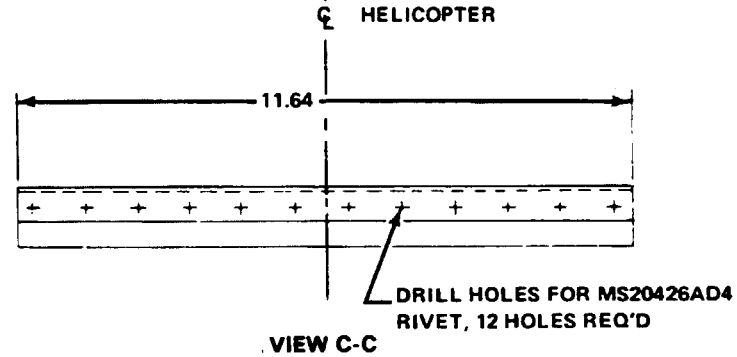
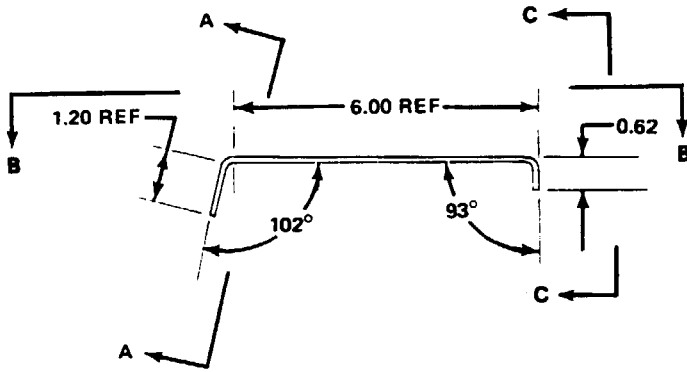
1. APPLY A CHEMICAL FILM NSN 8030-00-829-0376 PER TM 55-405-3 MANUAL
2. APPLY 1 COAT ZINC CHROMATE PRIMER NSN 8010-00-899-8825 PER TB 746-93-2 FOLLOWING APPLICATION OF CHEMICAL FILM
3. BEND RADII 0.18
4. DRILL RIVET HOLE AT TIME OF ASSEMBLY



SECTION A-A



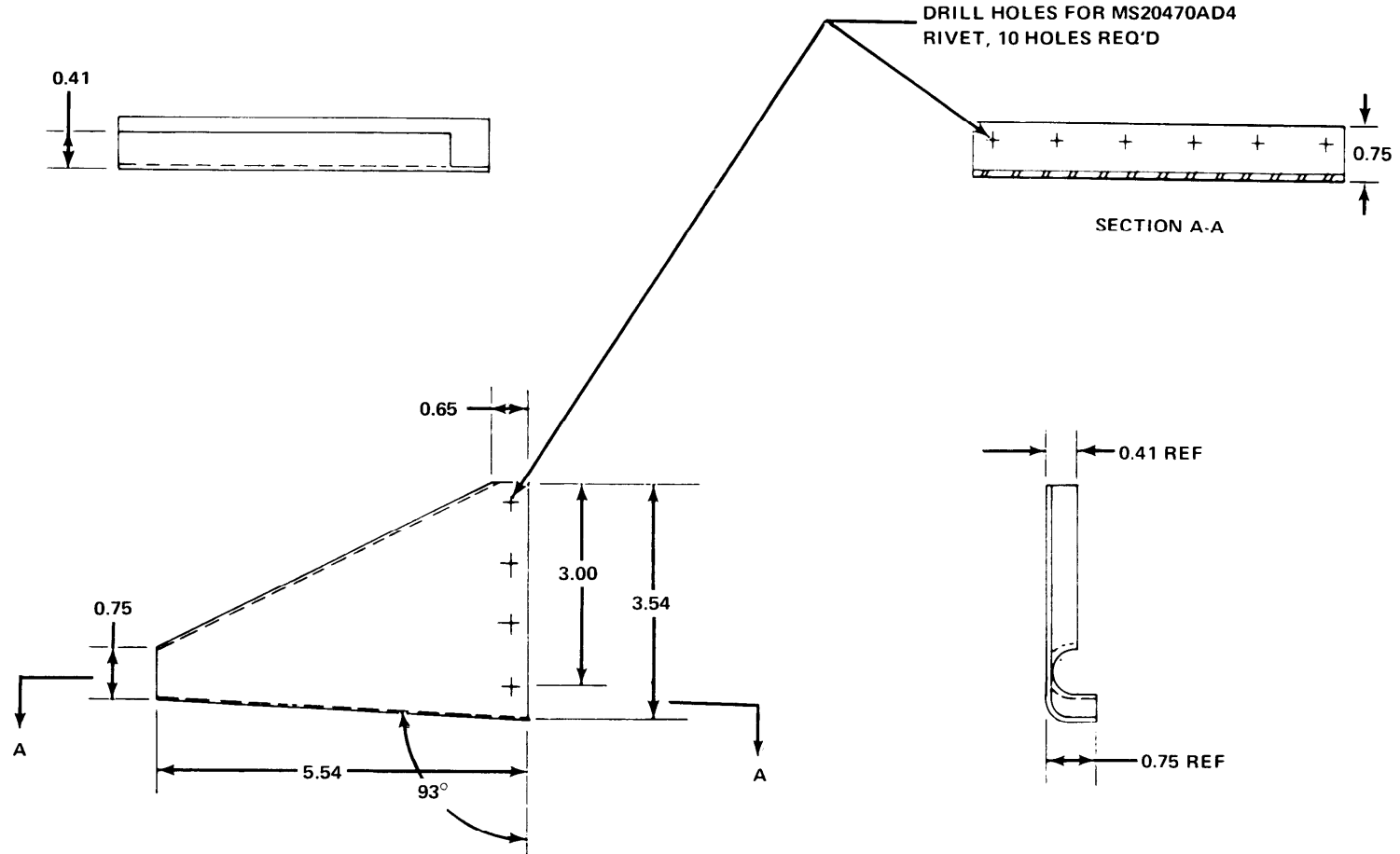
VIEW B-B



VIEW C-C

Figure D-198, Part Number  
(Sheet 3 of 6) Fabricate from:  
Material:

205-031-250-7 SUPPORT  
NSN 9535-00-840-2311  
2024 AL ALY Sheet, Federal Specification QQ-A-250/5,  
TEMP T3, 0.050 Inch Thick



NOTES:

1. APPLY A CHEMICAL FILM NSN 8030-00-829-0376 PER TM 55-405-3 MANUAL
2. APPLY 1 COAT ZINC CHROMATE PRIMER NSN 8010-00-899-8825 PER TB 746-93-2, FOLLOWING APPLICATION OF CHEMICAL FILM
3. BEND RADII 0.18
4. DRILL RIVET HOLES AT TIME OF ASSEMBLY

Figure D-198. Part Number

(Sheet 4 of 6) Fabricate from:  
Material:

**205-031-250-9 SHOWN-GUSSET**  
**205-031-250-10 OPPOSITE-GUSSET**  
**NSN 9535-00-640-2311**  
**2024 AL ALY Sheet, Federal Specification QQ-A-250/5,**  
**Temp T3, 0.050 Inch Thick**

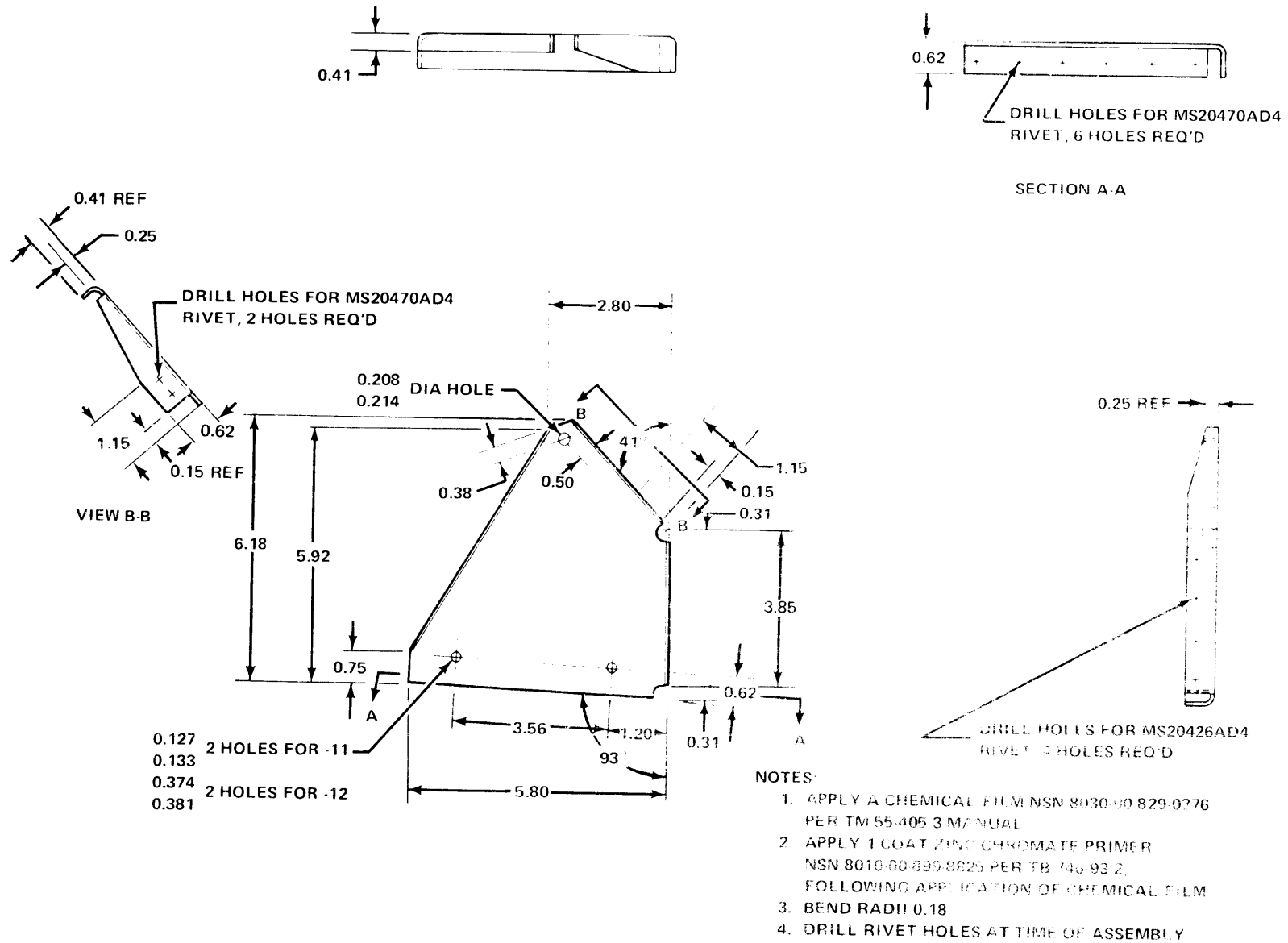
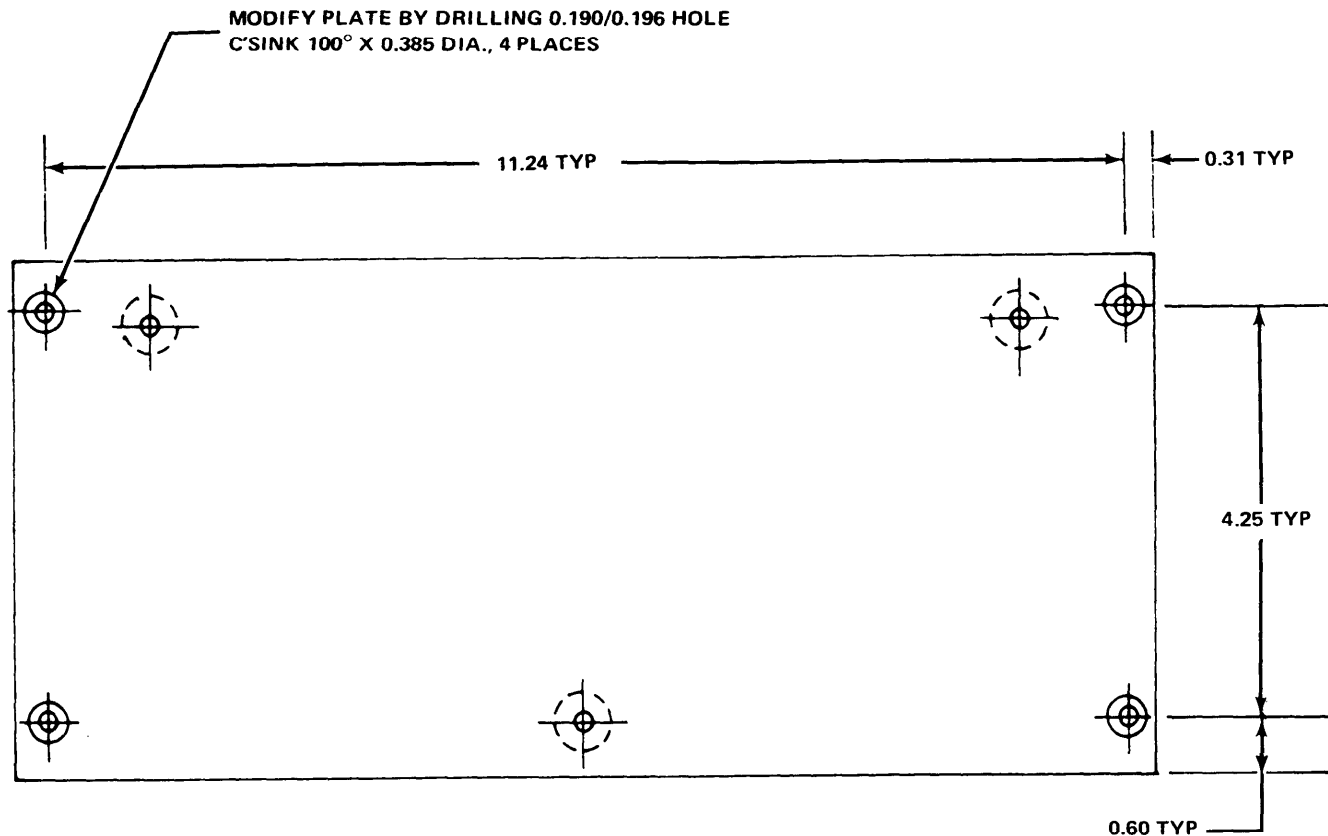


Figure D-198. Part Number

(Sheet 5 of 6) Fabricate from:  
Material:

**205-031-250-11 SHOWN-GUSSET**  
**205-031-250-12 OPPOSITE-GUSSET**  
**NSN 9535-00-640-2311**  
**2024 AL ALY Sheet, Federal Specification QQ-A-250/5,**  
**TEMP T3, 0.050 Inch Thick**



**Figure D-198.** Part Number 205-031-250-13 BASE PLATE  
 (Sheet 6 of 6) Fabricate from: NSN 1560-00-903-0798  
 Material:

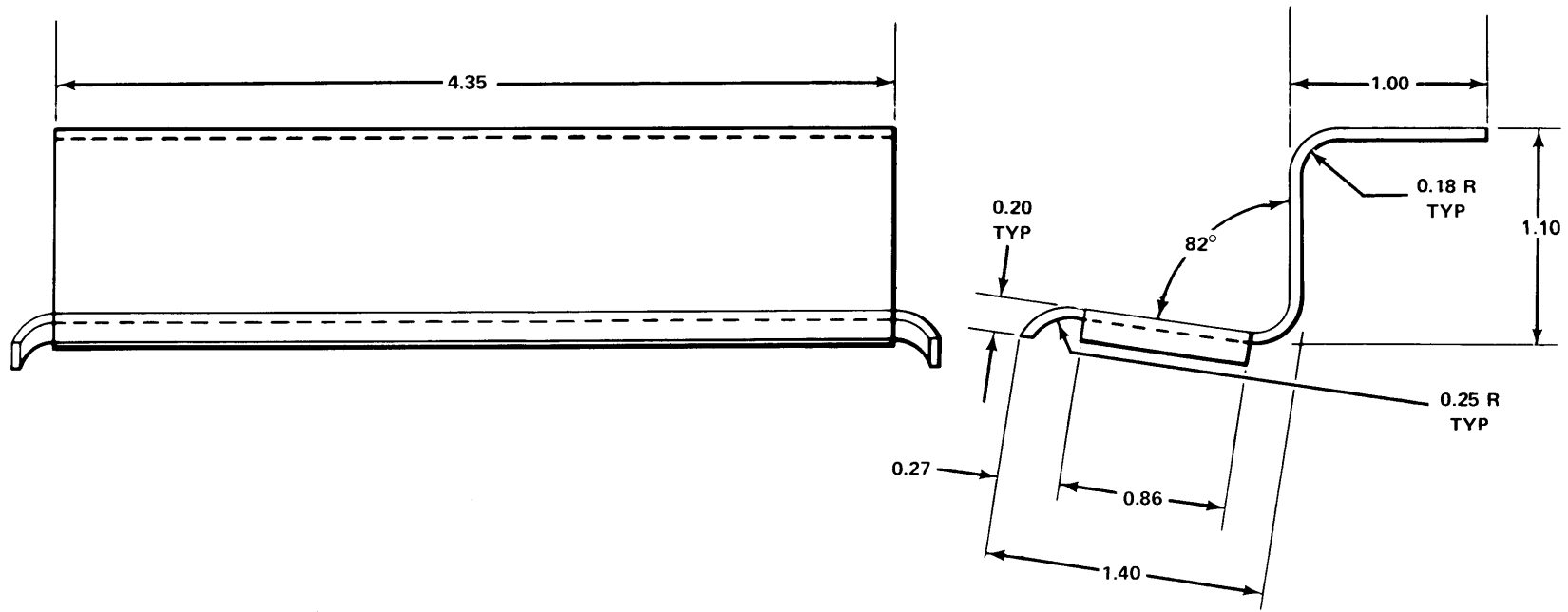


Figure D-199. Part Number 205-070-942-1 BRACKET  
Fabricate from: NSN 9535-00-640-2311  
Material: 2024 AL ALY Sheet, Federal Specification QQ-A-362,  
Temp T3, 0.050 In. Thick

Figure D-199.

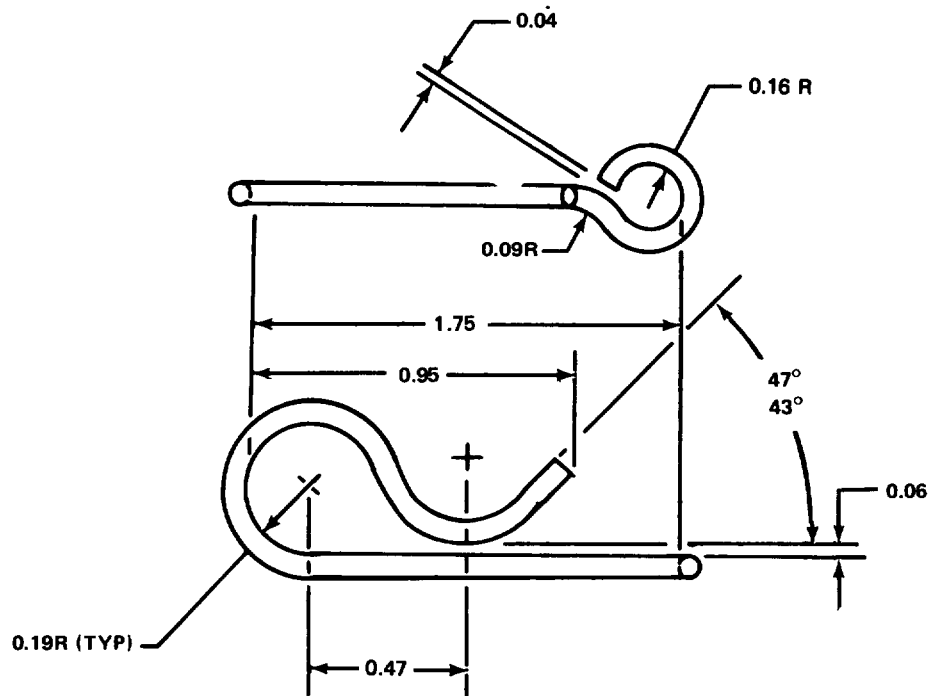


Figure D-200. Part Number 206-072-269-3 CLIP, Spring Tension  
 Fabricate from: NSN 9606-00-221-2682  
 Material: Wire, Steel Carbon, Spring, Federal Specification  
 MIL-W-6101-2, 0.67 Inch Dia

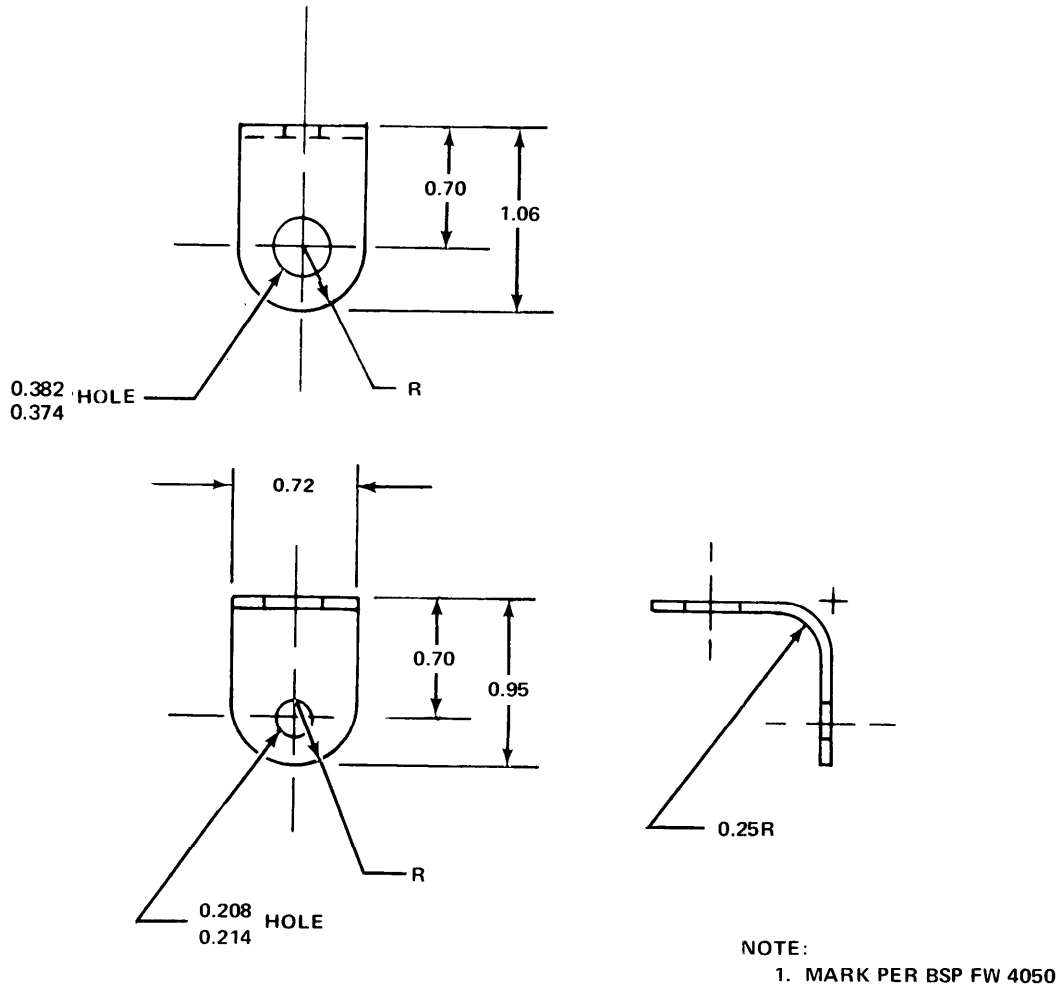


Figure D-201. Part Number **205-072-274-3 BRACKET, ANGLE**  
 Fabricate from: **NSN 9535-00-232-0378**  
 Material: **2024 AL ALY Sheet, Federal Specification QQ-A-250/5, 0.063 Inch Thick**

Figure D - 2 0 1 .

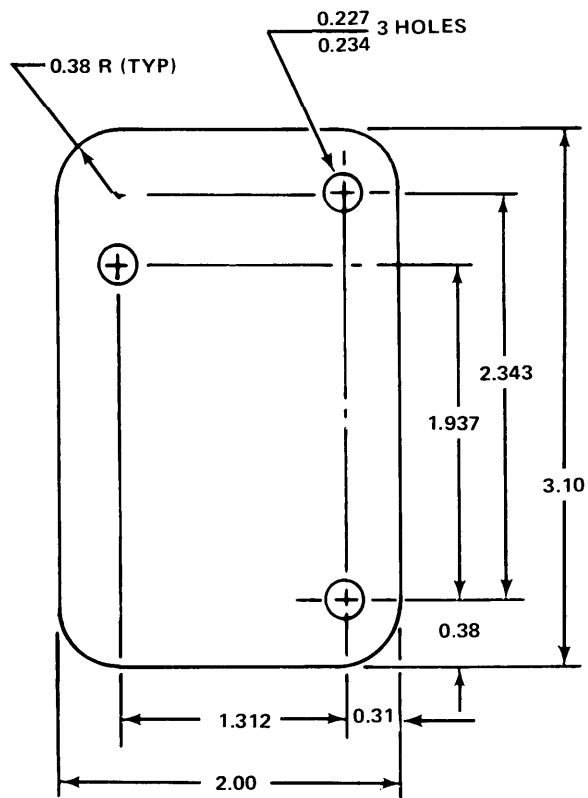
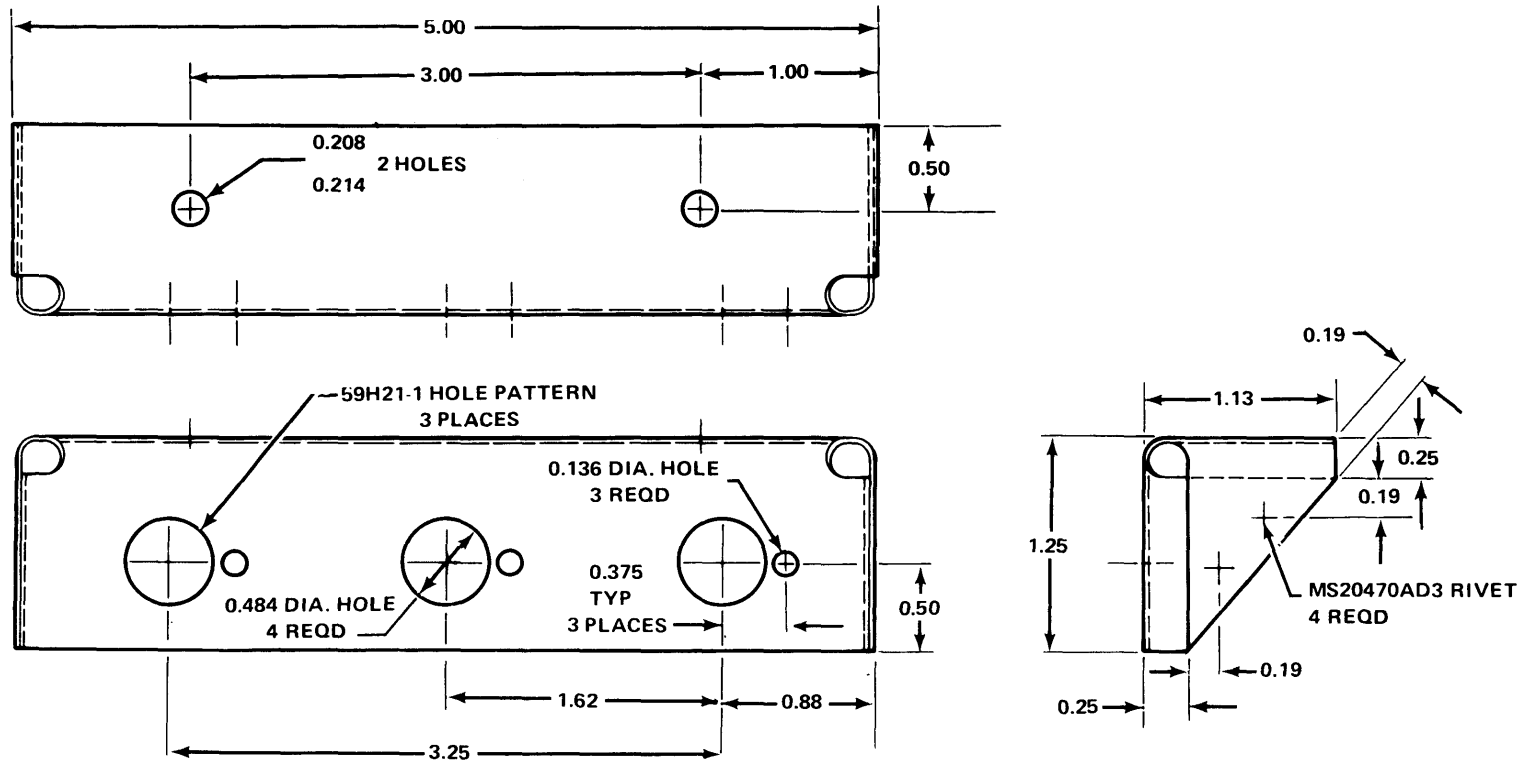


Figure D-202. Part Number 205-072-403-1 PLATE, Cover, Heating Valve  
 Fabricate from: NSN 9535-00-086-9729  
 Material: 2024 AL ALY Sheet, Federal Specification QQ-A-250/5,  
 0.032 Inch Thick

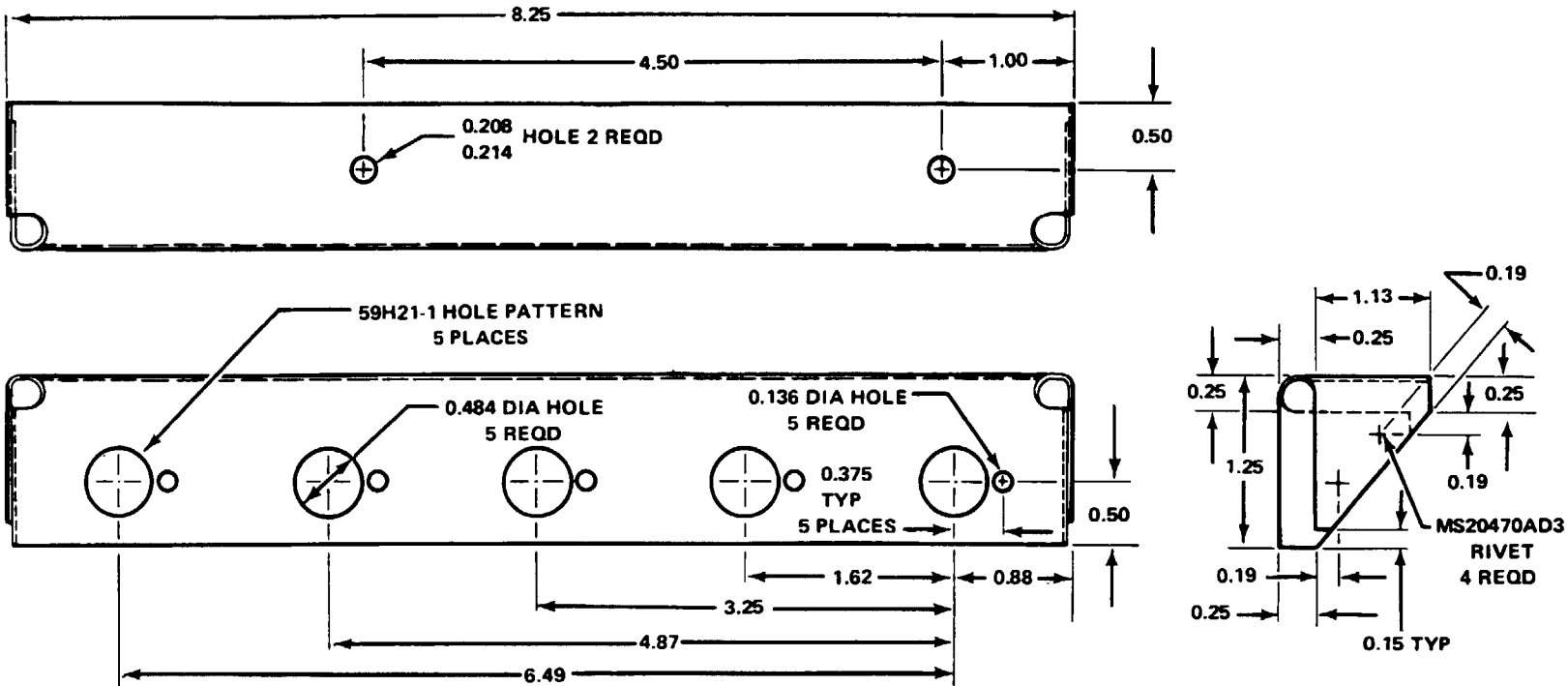
Figure D - 202 .





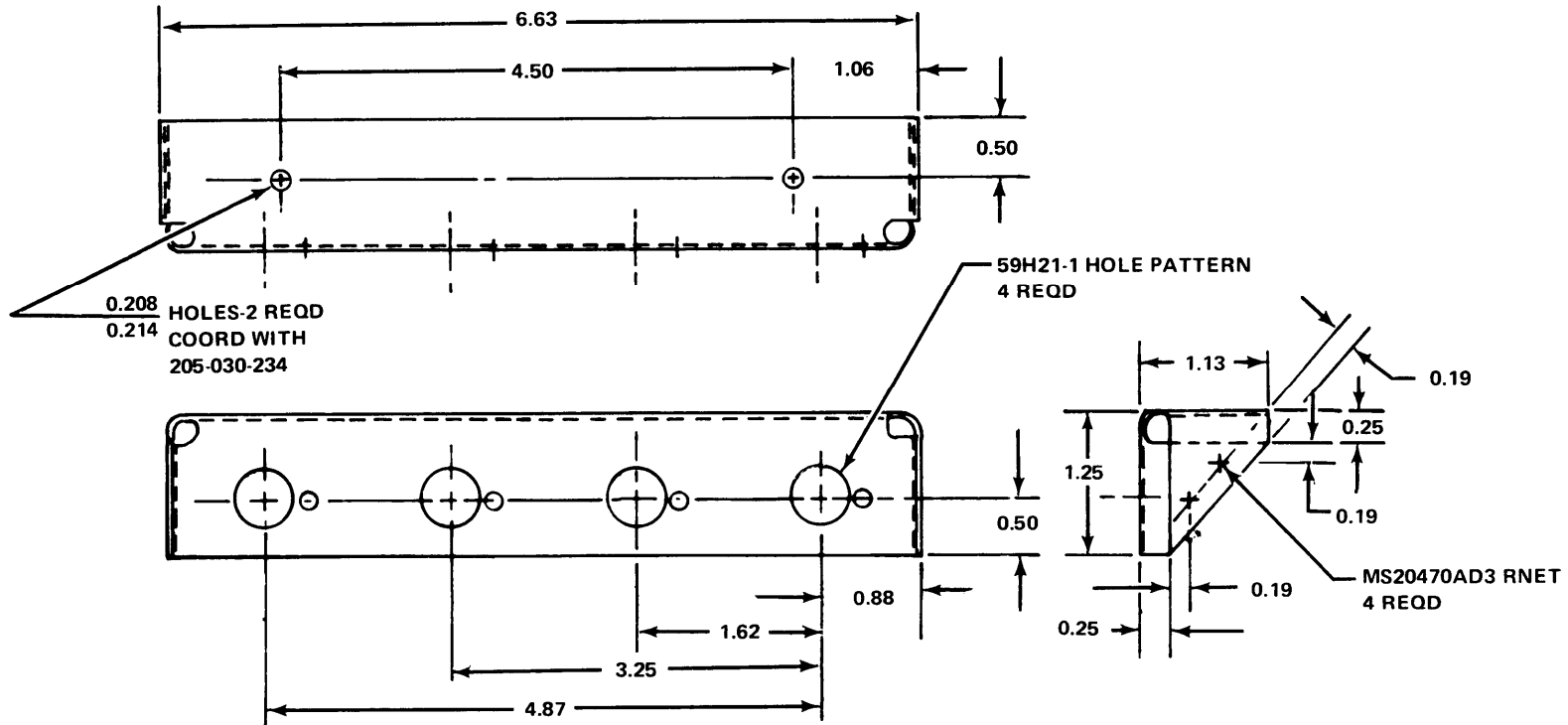
**Figure D-203.** Part Number 205-075-126-1, SUPPORT ASSEMBLY, Circuit Breaker  
 Fabricate from: NSN 9535-00-167-2279  
 Material: 2024 AL ALY Sheet, Federal Specification QQ-A-250/5, 0.032 Inch Thick

F I G U R E D - 2 0 3 .



**Figure D-204.** Part Number 205-075-126-9, SUPPORT ASSEMBLY, Circuit Breaker  
Fabricate from: NSN 9535-00-167-2279  
Material: 2024 AL ALY Sheet, Federal Specification QQ-A-250/5, 0.032 Inch Thick

*Figure D-204*



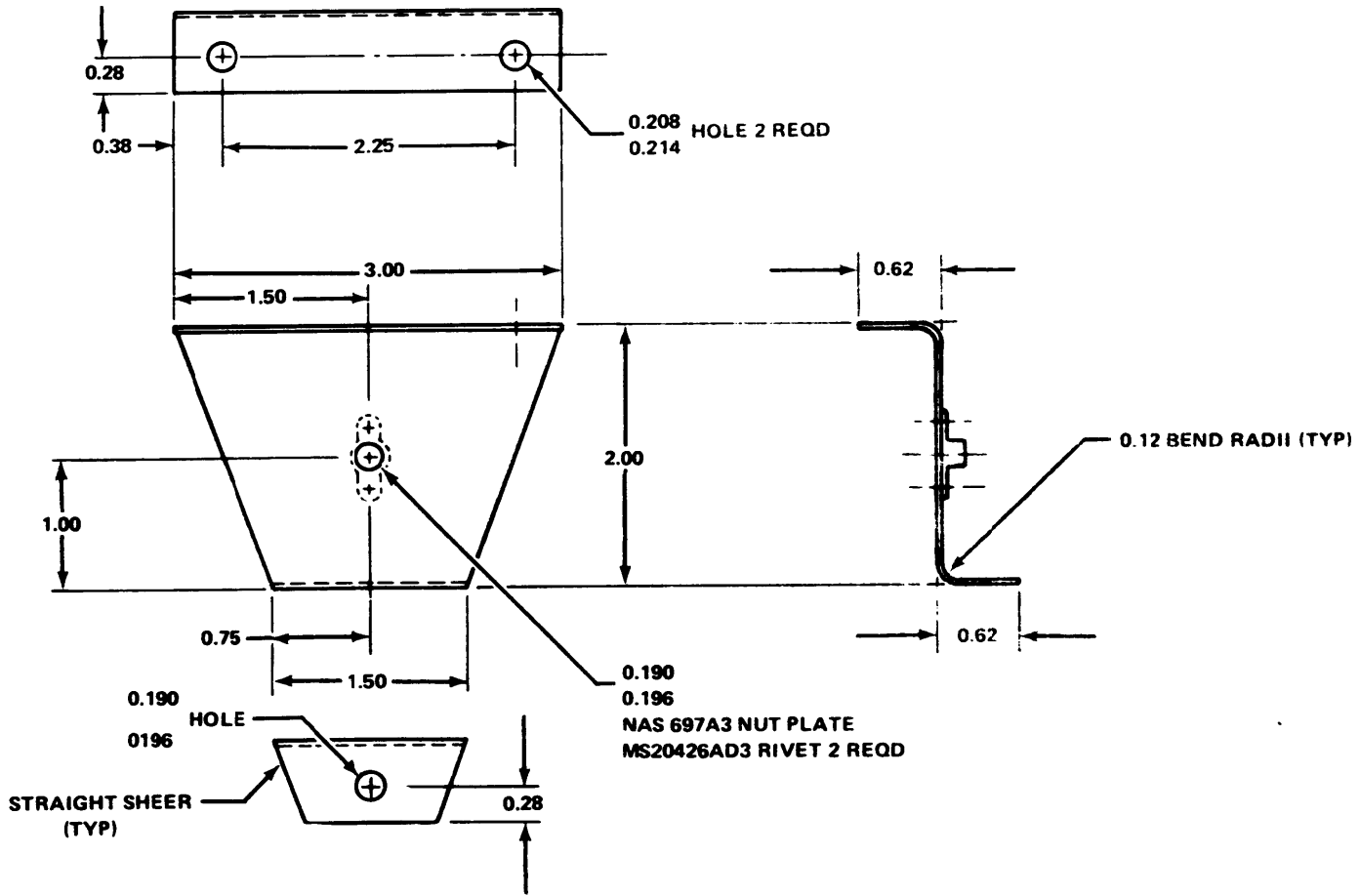
NOTES:

1. ALL BEND RADII TO BE 0.12 UNLESS OTHERWISE NOTED
2. BEND RELIEF RADII 0.16

**Figure D-205.** Part Number 205-075-126-13, SUPPORT ASSEMBLY  
 Fabricate from: NSN 9535-00-167-2279  
 Material: 2024 AL ALY Sheet, Federal Specification QQ-A-250/5, 0.032 Inch Thick

Figure D - 205 .

Figure D-206.



**Figure D-206.** Part Number 205-075-133-1, BRACKET ASSEMBLY, Cable Support  
 Fabricate from: NSN 9535-00-167-2279  
 Material: 2024 AL ALY Sheet, Federal Specification QQ-A-250/5, 0.032 Inch Thick

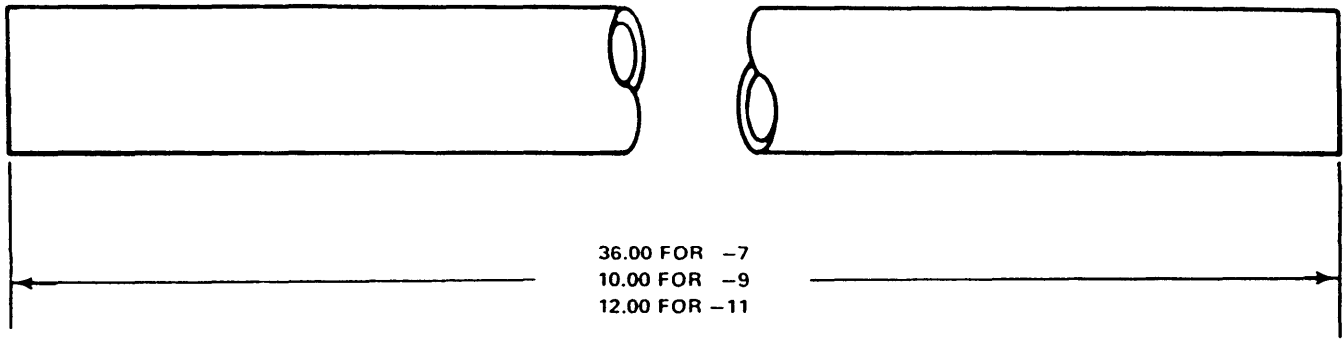
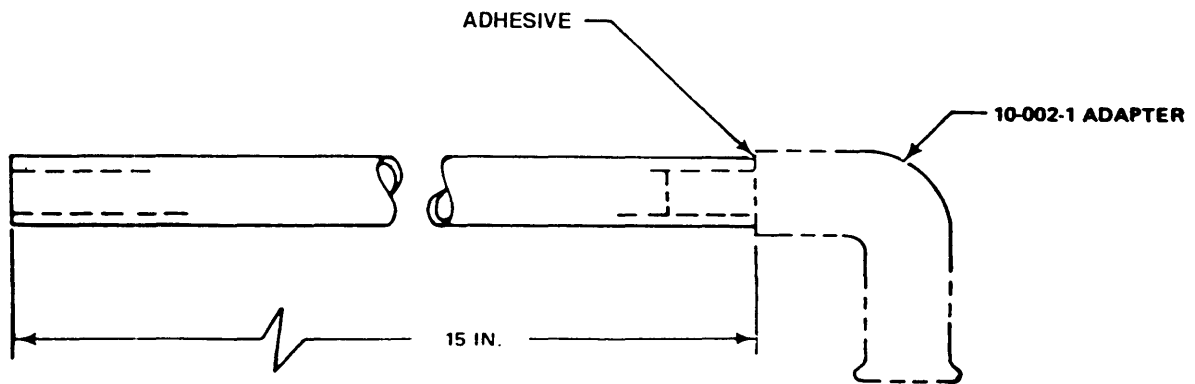


Figure D-207. Part Number: 205-075-134-1 TUBE, Battery Vent  
 Fabricate from: NSN 4710-00-278-8726  
 Material: 5052 AL ALY Tube, Federal Specification WW-T-700/4  
 Type 1, 3/8 Inch Dia, 0.049 inch Wall Thickness



**NOTES:**

1. PRIOR TO BOND CLEAN SURFACES WITH ACETONE  
 CHEM PURE OR METHYL ETHYL KETONE CHEM PURE
2. ALTERNATE MAT'L: RUBBER - BLACK, MIL-R-6855,  
 CLASS II - GRADE 60

Figure D-208 Part Number: 205-075-135-15 TUBE  
 Fabricate from: NSN 4720-00-540-3644  
 Material: Tubing, Black Synthetic, Federal Specification  
**MIL-R-6855 Class 11**, Grade 40, 3/8 Inch ID,  
 1/8 Inch Wall Thickness  
 Adhesive, MIL-A-46050-102BT NSN 8040-00-142-9193



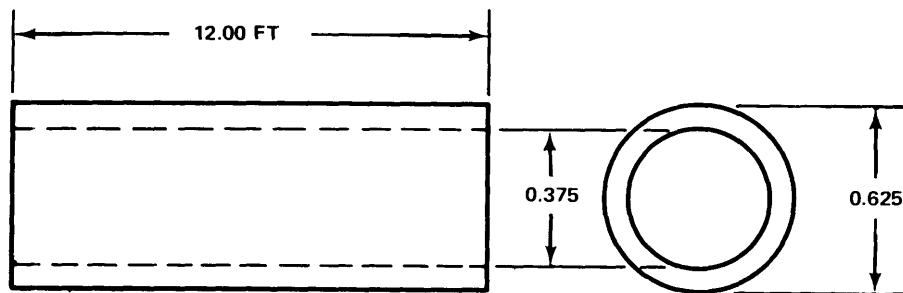


Figure D-209. Part Number 205-075 -142-3 TUBE  
Fabricate from: NSN 4720-00-231-2483  
Material: Tubing, Rubber, Natural, Federal Specification  
ZZ-T-831, Grade A, 3/8 Inch ID, 1/8 Inch Wall Thickness

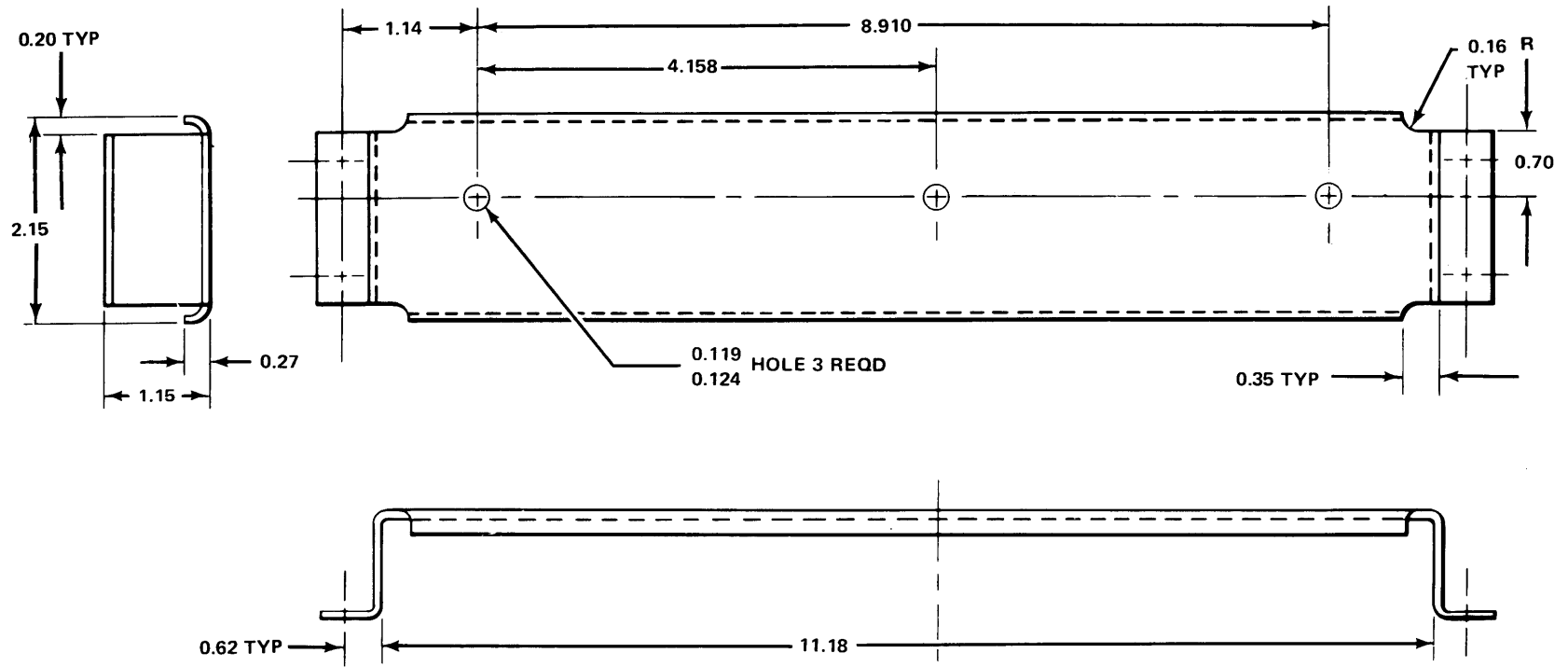
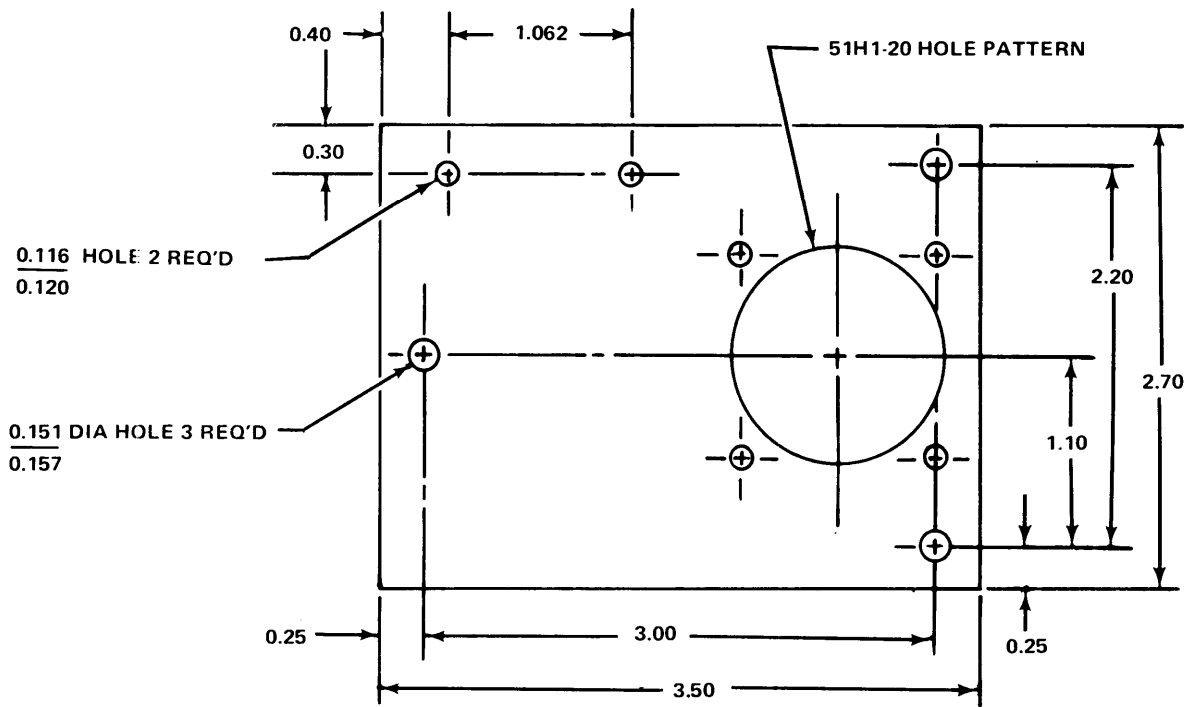
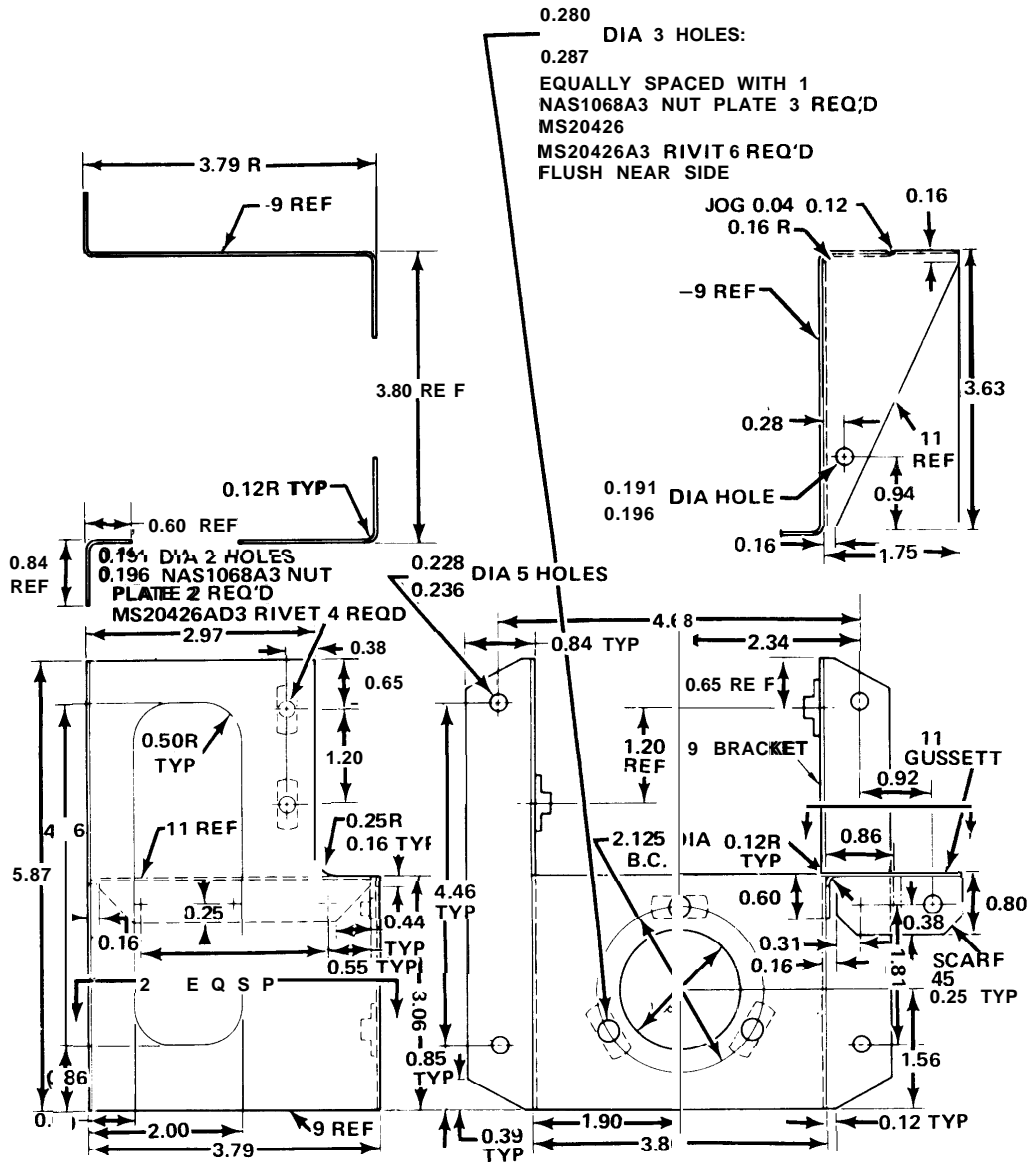


Figure D-210. Part Number 205-075-144-3, BRACKET  
 Fabricate from: NSN 9535-00-167-2279  
 Material: 2024 AL ALY Sheet, Federal Specification QQ-A-250/5, 0.032 Inch Thick

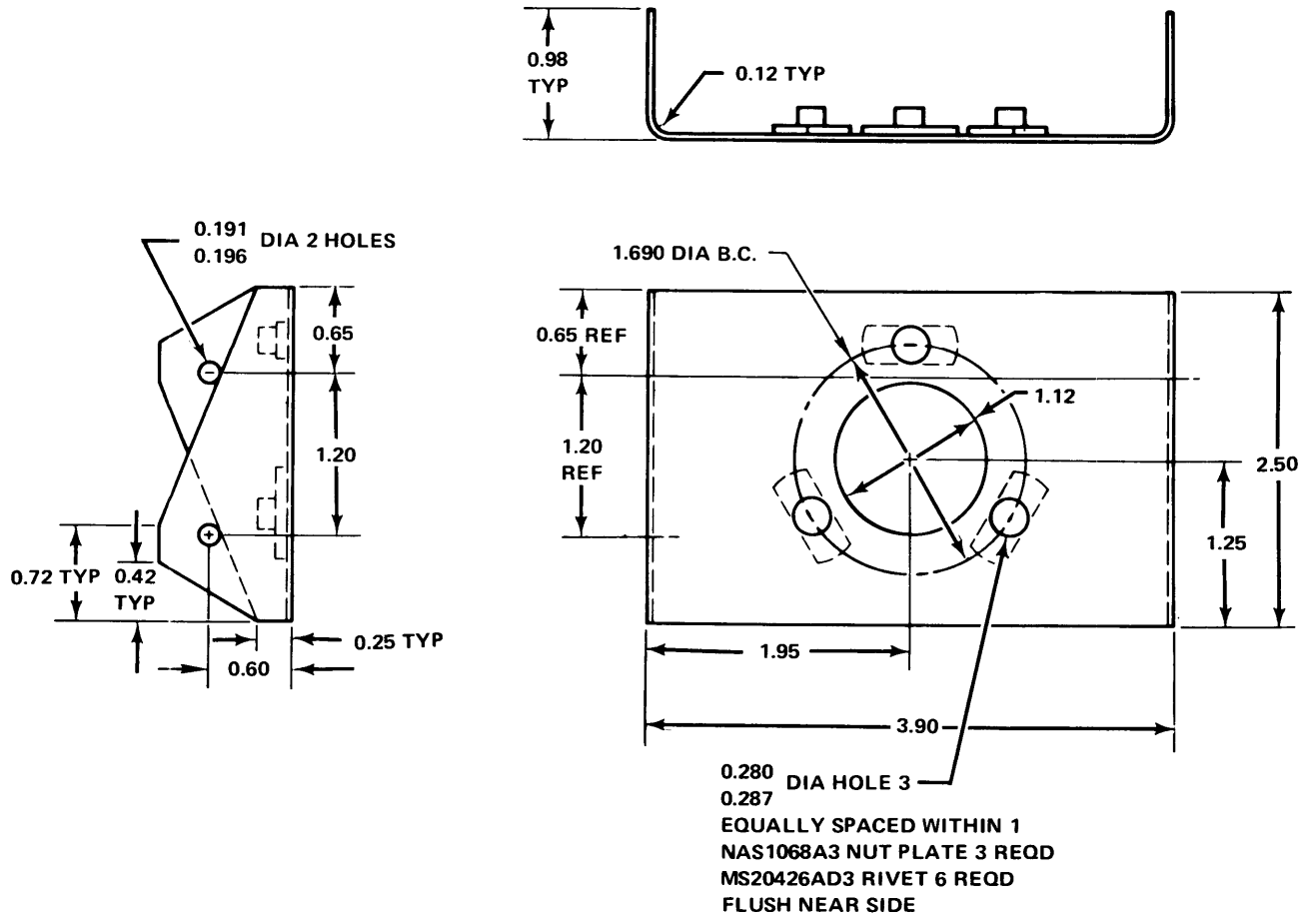


**Figure D-211.** Part Number 205-075-229-1, MOUNTING PLATE  
 Fabricate from: NSN 9535-00-554-1412  
 Material: 2024 AL ALY Sheet, Federal Specification QQ-A-362, 0.050 Inch Thick





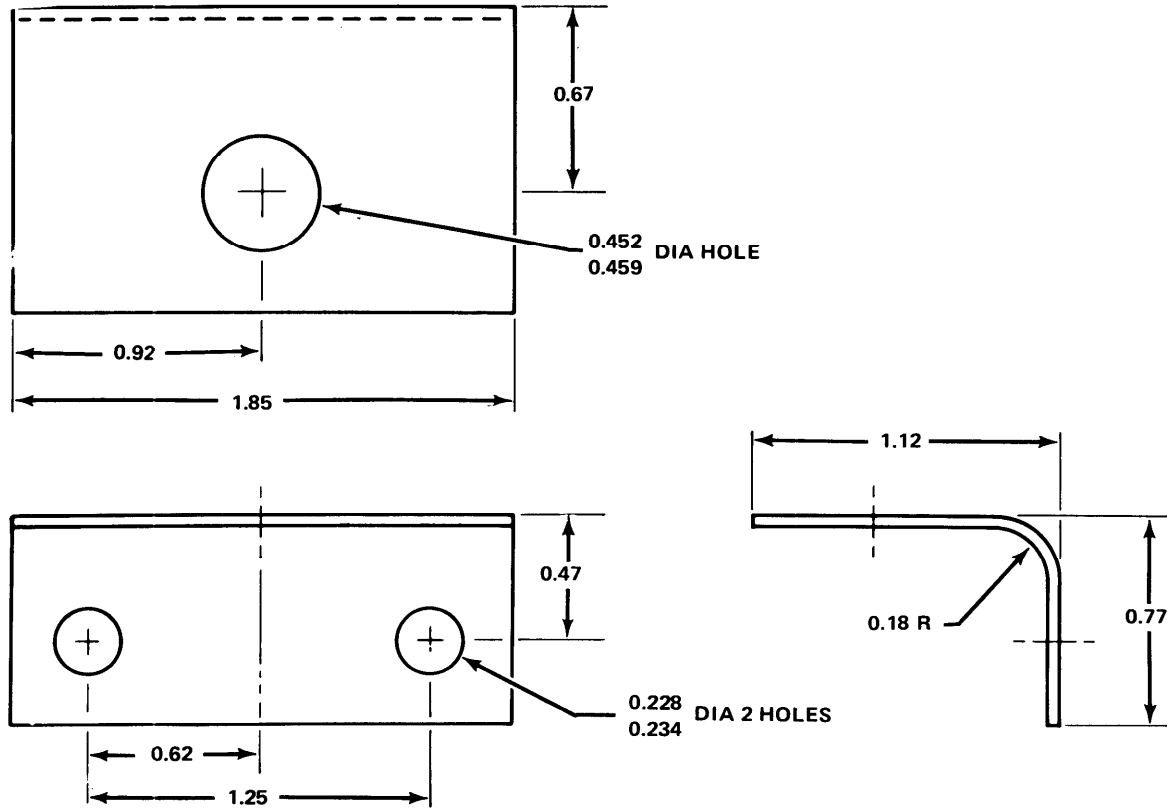
**Figure D-212.** Part Numbers 205-076-101-1 BRACKET ASSEMBLY  
 205-076- 101-3  
 Fabricate from: NSN 9535-00-167-2280  
 Material: 2024 AL ALY Sheet, Federal Specification QQ-A-250/5, 0.040 Inch Thick



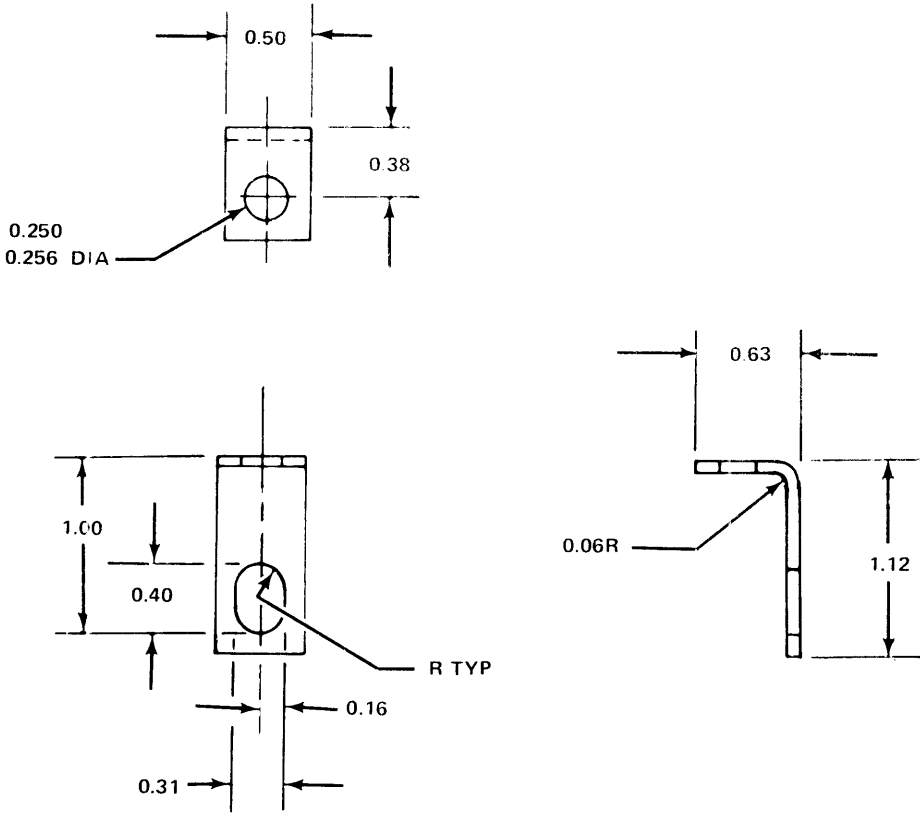
**Figure D-213.** Part Numbers

Fabricate from:  
Material:

205-076-101-1 BRACKET ASSEMBLY  
205-076-101-3  
NSN 9539-00-167-2280  
2024 AL ALY Sheet, Federal Specification QQ-A-250/5, 0.040 Inch Thick



**Figure D-214.** Part Number 205-076-102-1 BRACKET  
Fabricate from: NSN 9635-00-640-2311  
Material: 2024 AL ALY Sheet, Federal Specification QQ-A-362,  
0.050 Inch Thick



**Figure D-215.** Part Number 205-076-118-1 BRACKET, Angle  
Fabricate from: NSN 9535-00-232-0378  
Material: 2024 AL ALY Sheet, Federal Specification QQ-A-250/5, 0.063 Inch Thick

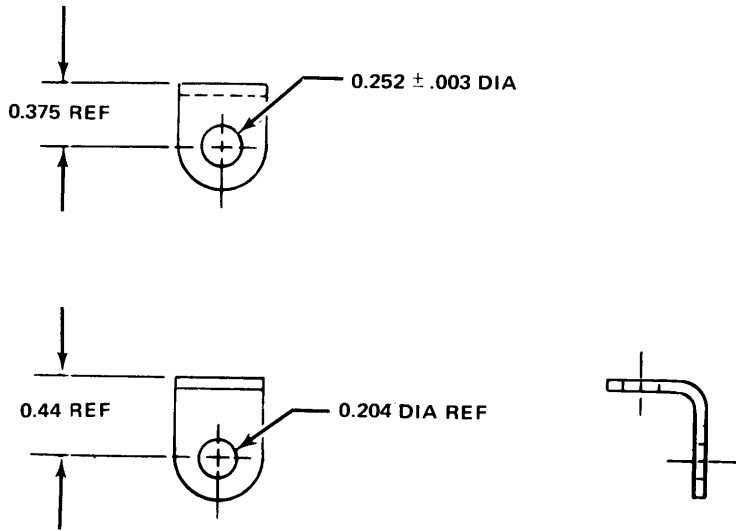
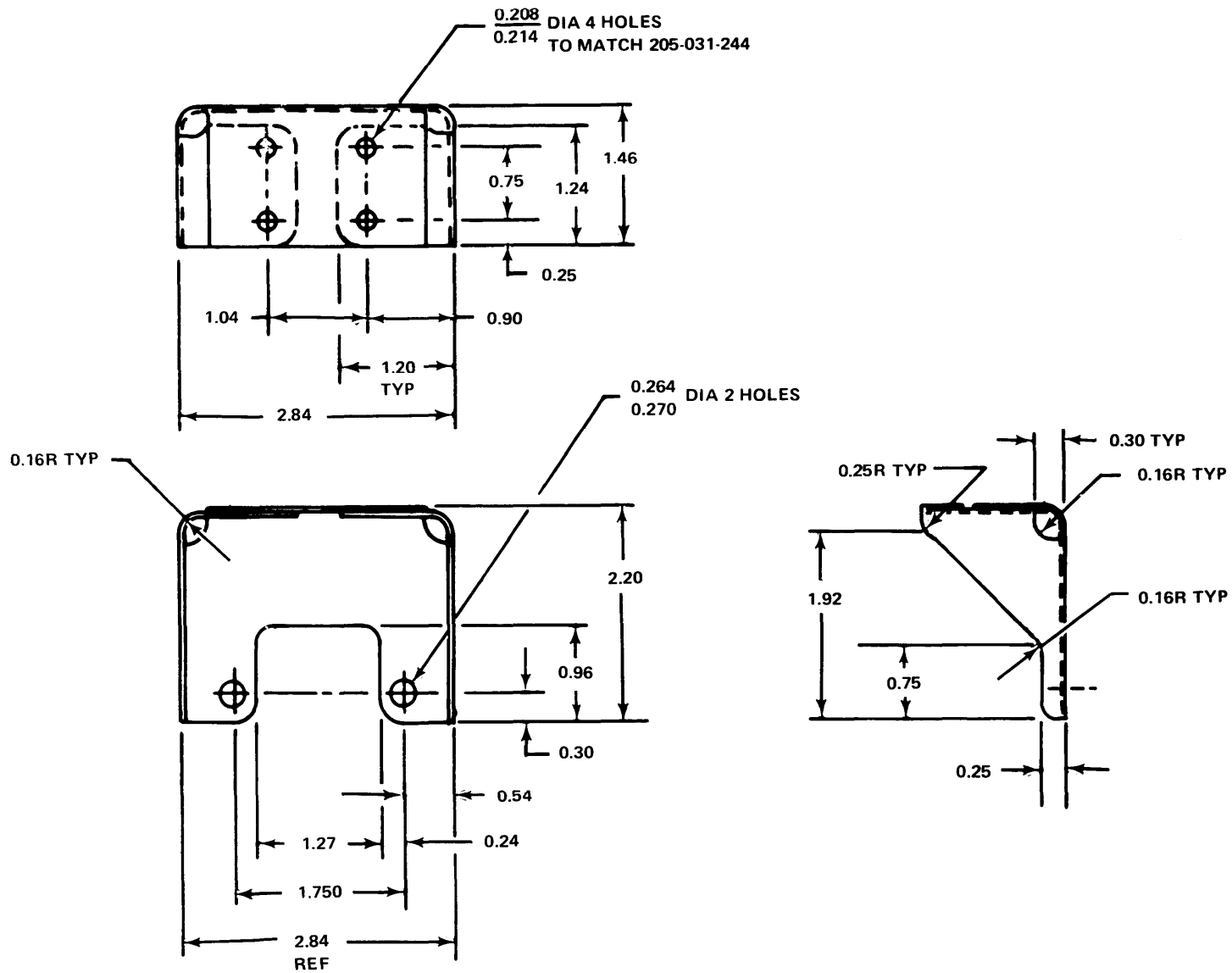
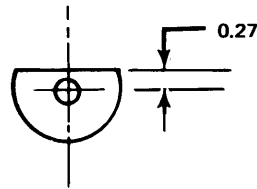


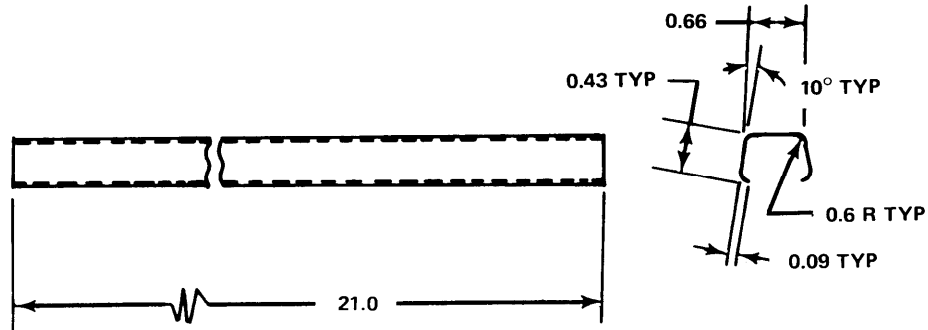
Figure D-216. Part Number 205-076-230-1 BRACKET, ANGLE  
Fabricate from: NSN 9535-00-232-0378  
Material: 2024 AL ALY Sheet, Federal Specification QQ-A-250/5, 0.063 Inch Thick



**Figure D-217.** Part Number 205-076-234-1 BRACKET, HYDRAULIC FILTER  
 Fabricate from: NSN 9535-00-167-2280  
 Material: 2024 AL ALY Sheet, Federal Specification QQ-A-250/5, 0.040 Inch Thick



DETAIL OF -11 WASHER



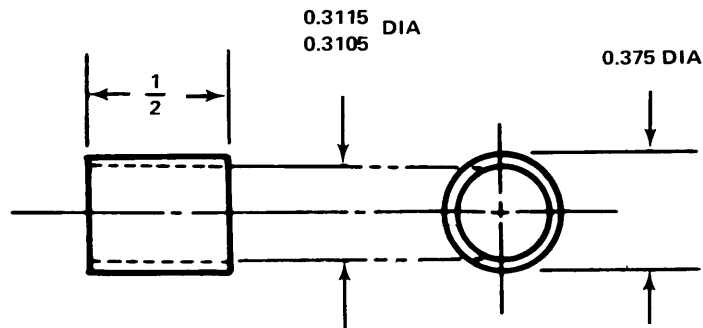
DETAIL OF -15 CHANNEL

NOTES:

1. ZINC CHROMATE FINISH

Figure D-21 8.

Part Number	205-706-025-11 WASHER
Fabricate from:	NSN 5310-00-167-0766
Part Number	205-706-025-16 CHANNEL
Fabricate from:	NSN 9535-00-232-0543
Material:	Washer, Flat Steel, Cadmium Plated Make From AN970-4 Washer 2024 AL ALY Sheet, Federal Specification QQ-A-250/5, 0.016 Inch Thick



NOTE:

1. BREAK SHARP EDGES 0.005 TO 0.010

Figure D-219.

Part Number	11021-1 SLEEVE, Solenoid Shaft
Fabricate from:	NSN 9510-00-229-4818
Material:	Steel Bar, Carbon, Cold, Federal Specification QQ-S-634, Comp C1045, 0.375 Inch Dia

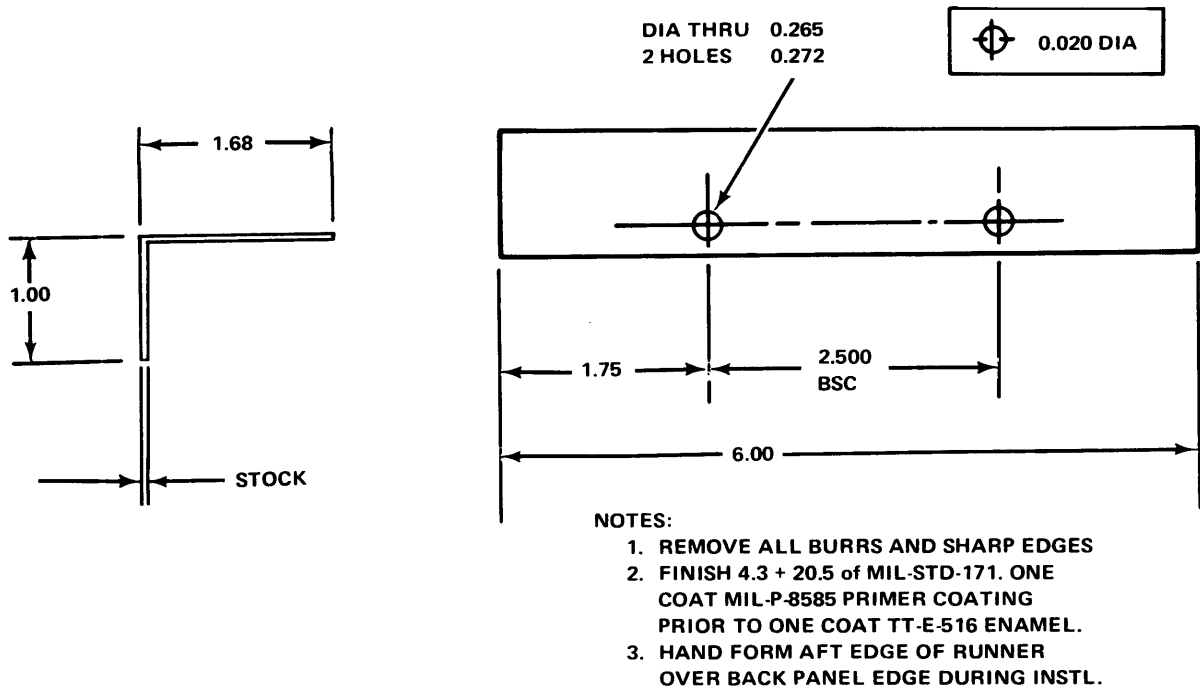


Figure D-220.

Part Number 178065-1 RUNNER, Metal  
 Fabricate from: NSN 9535-00-167-2279  
 Material: 2024 AL ALY Sheet, Federal Specification QQ-A-250/5, 0.032 Inch Thick

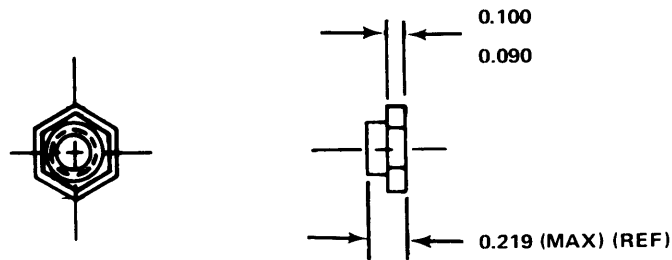
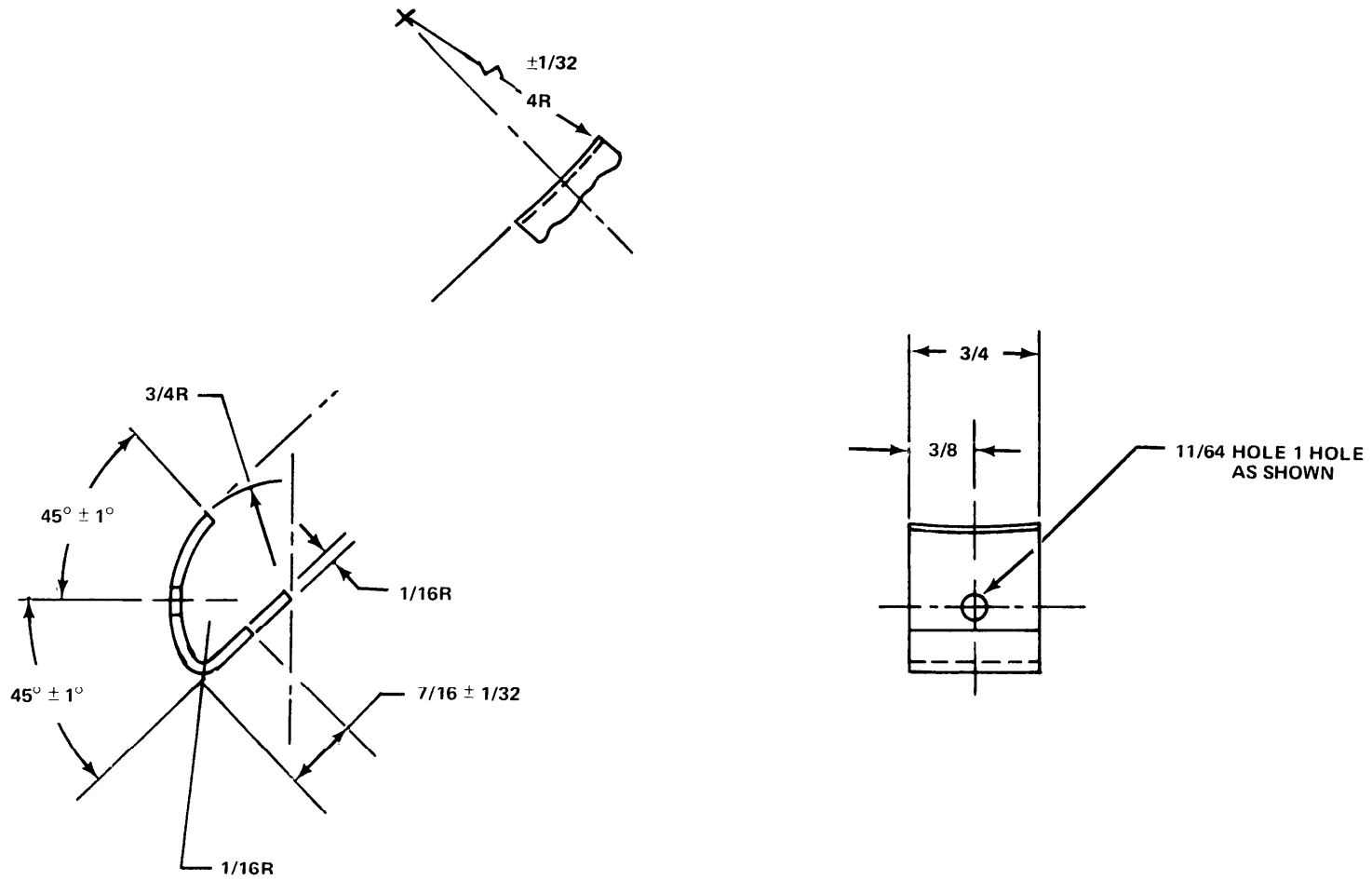


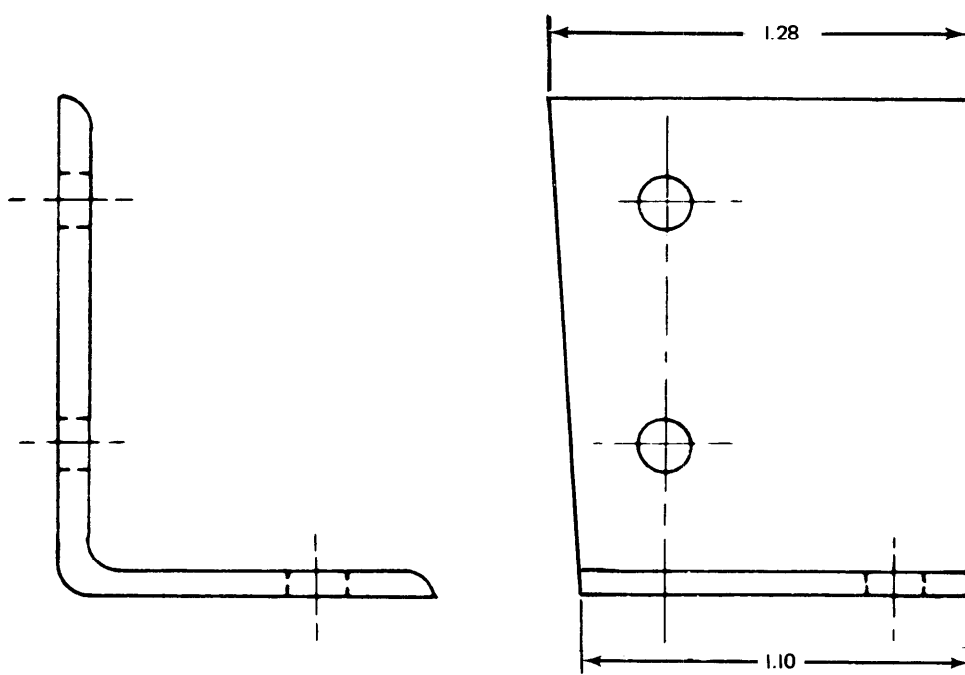
Figure D-221.

Part Number 528307, NUT, Self-Locking  
 Fabricate from: NSN 5310-00-807-1475  
 Material:





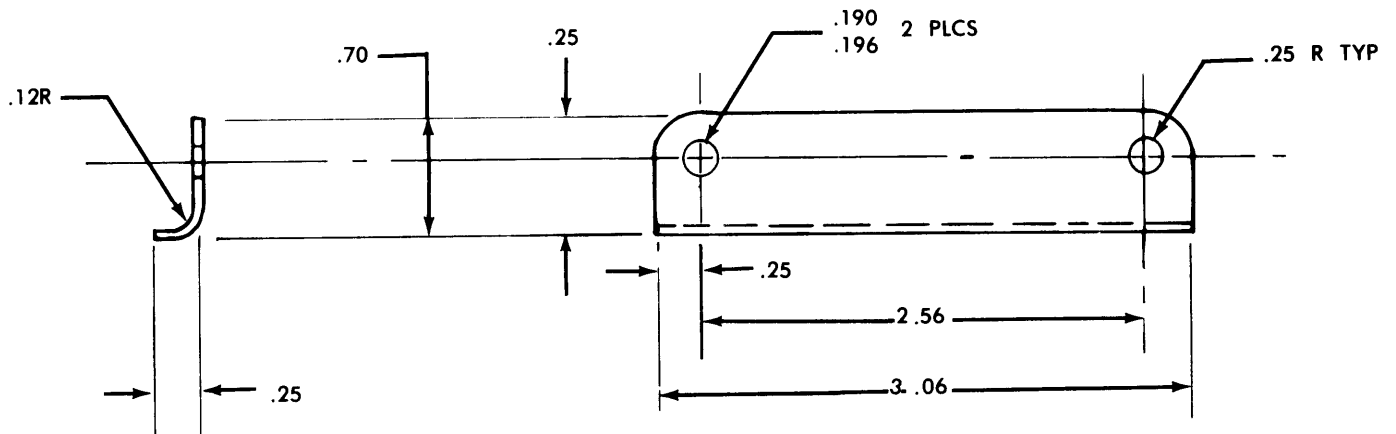
**Figure D-222.** Part Number 9524491 CLIP, VALVE  
 Fabricate from: NSN 9535-00-554-1417  
 Material: 2024 AL ALY Sheet, Federal Specification QQ-A-250/5, 0.063 Inch Thick



- NOTES:
1. DRILL HOLES UPON ASSEMBLY
  2. CUT WIDTH FROM BULK STOCK AS SHOWN

**Figure D-223.** Part Numbers      205-030-919-37 SHN CLIP  
    205-030-919-38 OPP  
 Fabricate from:                    NSN 9540-00-145-5715  
 Material:                            2024 AL ALY Structural Angle Aluminum, Make From AND 10134-2001





PART NUMBER 205-060-202 LINK  
 FABRICATE FROM : NSN 9535-00-167-280  
 MATERIAL: 2024 AL ALY SHEET,  
 FEDERAL SPEC QQ-A-250/5 .040 INCH THICK

FIGURE D-224

PART NUMBER	NOMENCLATURE	FABRICATE FROM	ID	OD	LENGTH
E1112-32-14	SLEEVE-INSULATING	5970-00-235-2728	0.375	0.400	AS REQD.
Y1152-1-6	"	5970-00-235-2721	0.057	0.086	AS REQD.
Y1152-1-11	"	5970-00-235-2733	0.102	0.121	AS REQD.

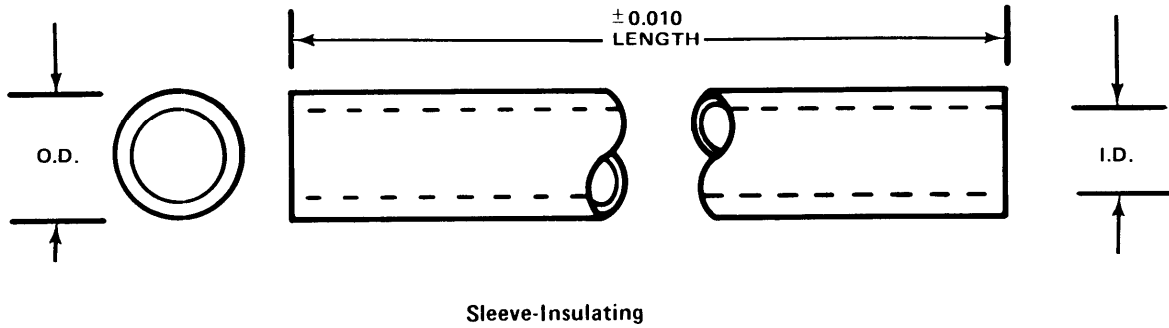


Figure D-225.

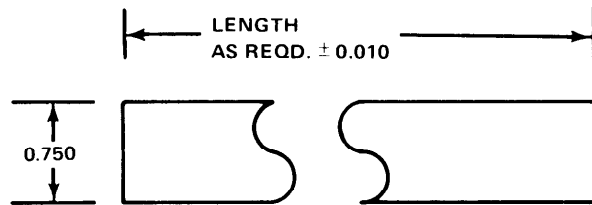
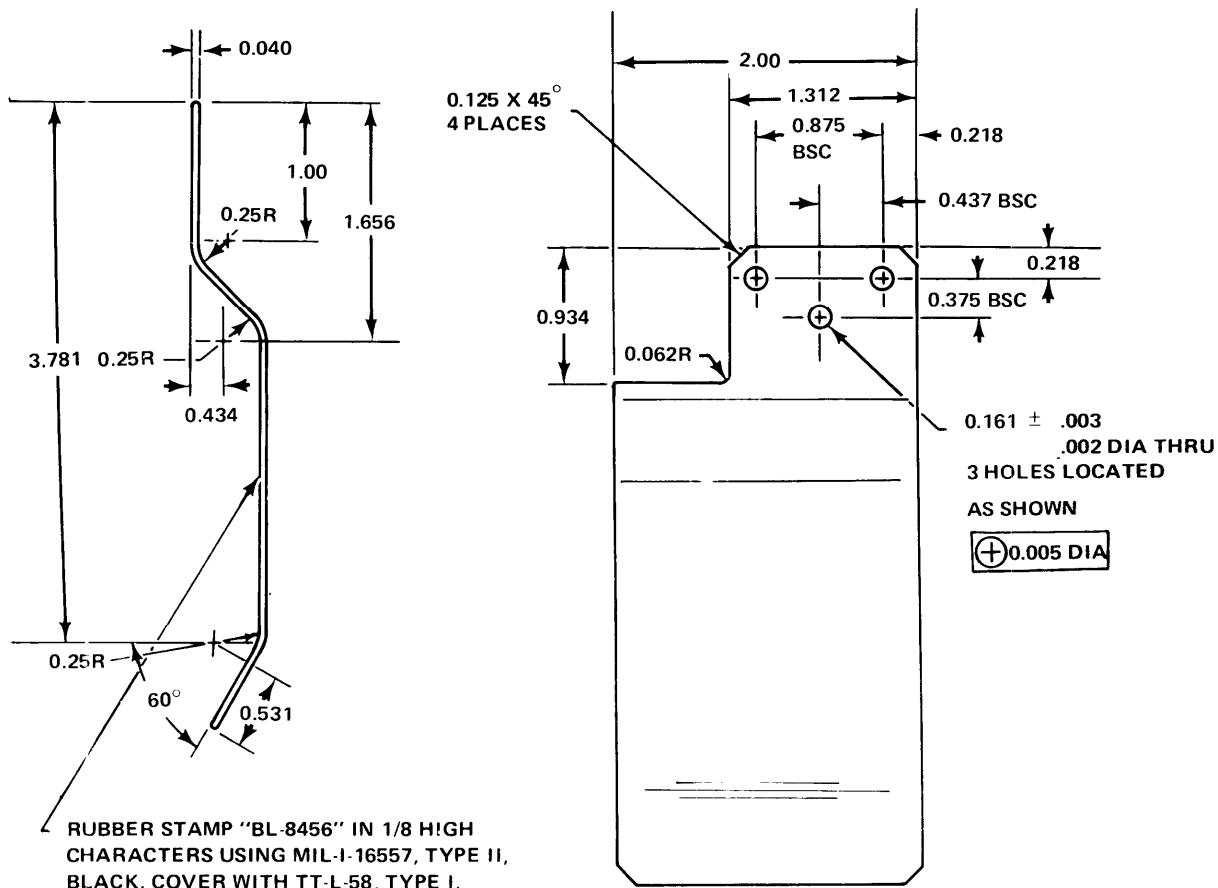


Figure D-226.

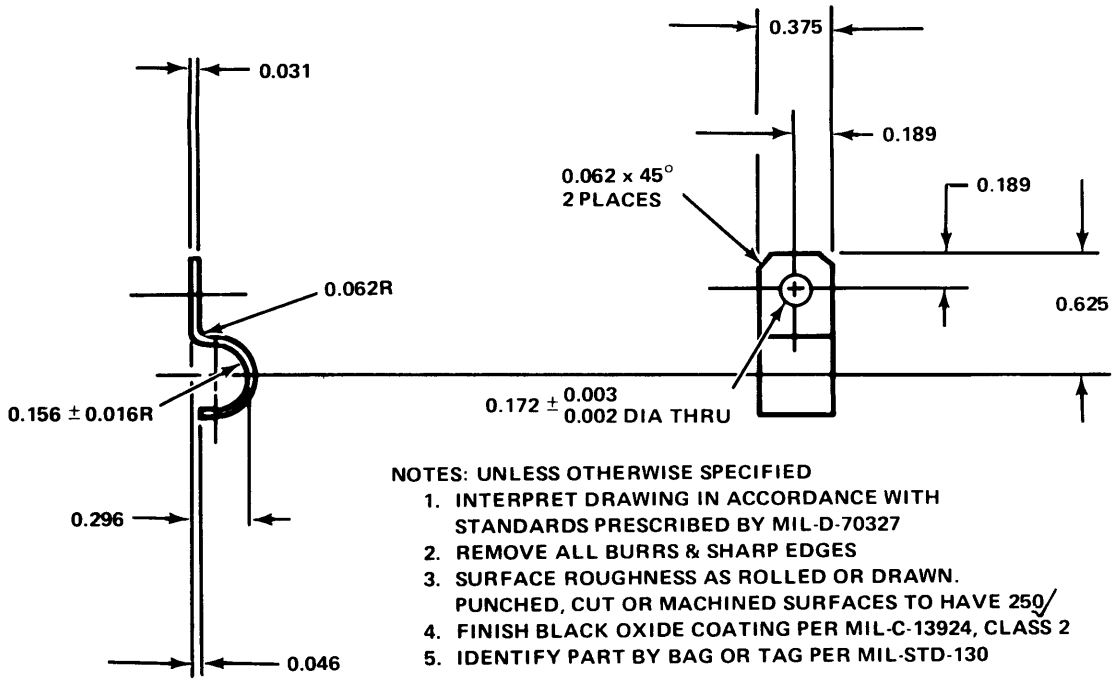
Part Number: Y-1159-2-3, Tape, Glass Cloth, Pressure Sensitive  
 Fabricate from: NSN 5970-00-284-8565  
 Material:



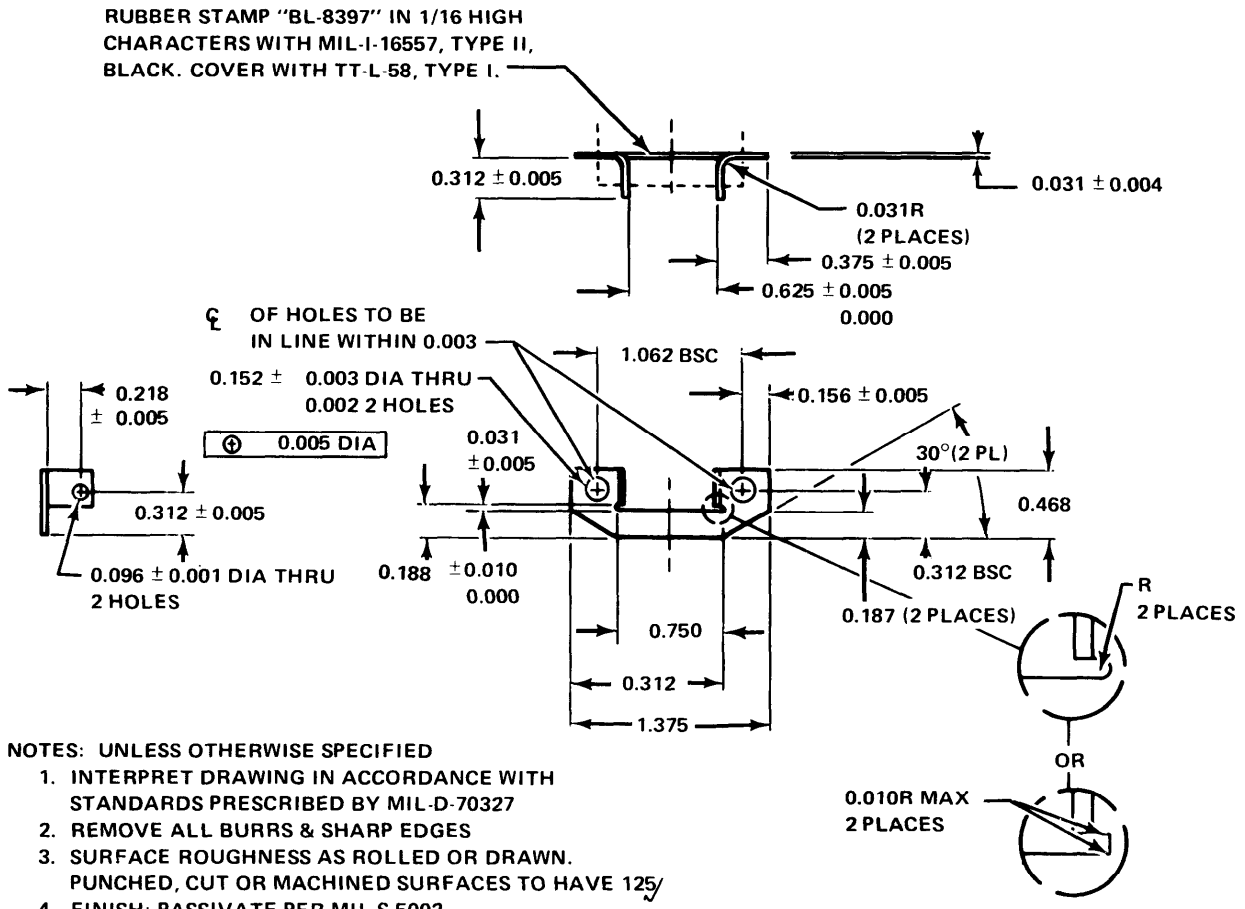
NOTES: UNLESS OTHERWISE SPECIFIED

1. INTERPRET DRAWING IN ACCORDANCE WITH STANDARDS PRESCRIBED BY MIL-D-70327.
2. REMOVE ALL BURRS & SHARP EDGES.
3. SURFACE ROUGHNESS AS ROLLED OR DRAWN. PUNCHED, CUT, OR MACHINED SURFACES TO HAVE 250/
4. FINISH ALL OVER WITH CHEMICAL FILM PER MIL-C-5541, TYPE I, CLASS 1, GRADE C.

**Figure D-227.** Part Number: BL8456 FMC08484 Shroud, Motor, Right Side  
 Fabricate from: NSN 9515-00-580-0405  
 Material:

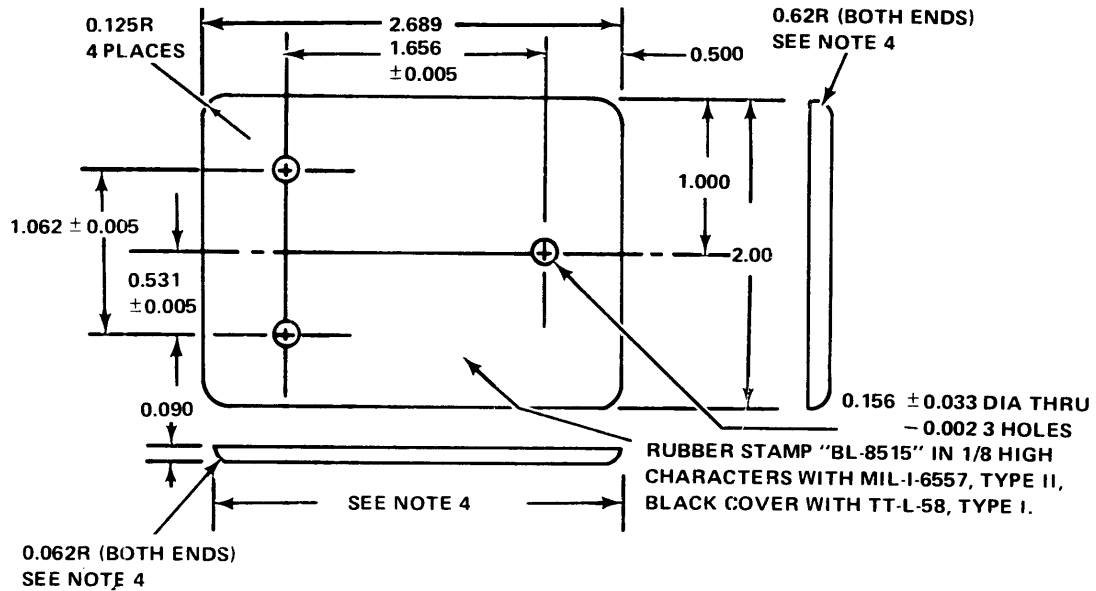


**Figure D-228.** Part Number BL8453 FMC08484 Clamp, Cable  
 Fabricate from: NSN 9535-00-580-5516  
 Material: Metal Strip-Steel Corrosion, Federal Specification MIL-S-5059, Comp 201, 0.032 Inch Thick



**Figure D-229.** Part Number BL8379 FMC08484 Bracket, Trunnion Actuator  
 Fabricate from: NSN 9515-00-580-5516  
 Material: Metal Strip-Steel Corrosion, Federal Specification MIL-S-5059 Comp 302, 0.032 Inch Thick

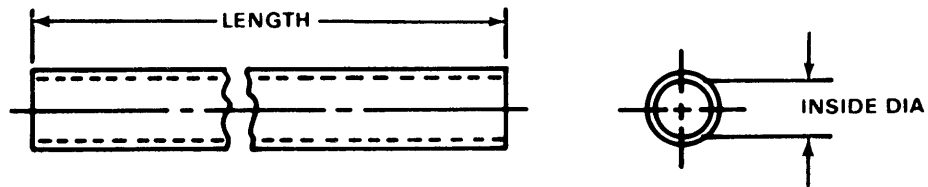




NOTES: UNLESS OTHERWISE SPECIFIED

1. INTERPRET DRAWING IN ACCORDANCE WITH STANDARDS PRESCRIBED BY MIL-D-70327.
2. REMOVE ALL BURRS & SHARP EDGES
3. SURFACE ROUGHNESS AS ROLLED OR DRAWN. PUNCHED, CUT OR MACHINED SURFACES TO HAVE 250 $\mu$
4. SURFACES DESIGNATED SHALL BE SMOOTH AND FREE OF SCRATCHES, BURRS OR PITS WITH SHARP EDGES; LIQUID HONE WITH 325 GRIT OR ACHIEVE EQUIVALENT FINISH BY OTHER MEANS IF NECESSARY TO MEET THE ABOVE REQUIREMENTS.
5. FINISH: ANODIZE PER MIL-A-8625, TYPE 1.

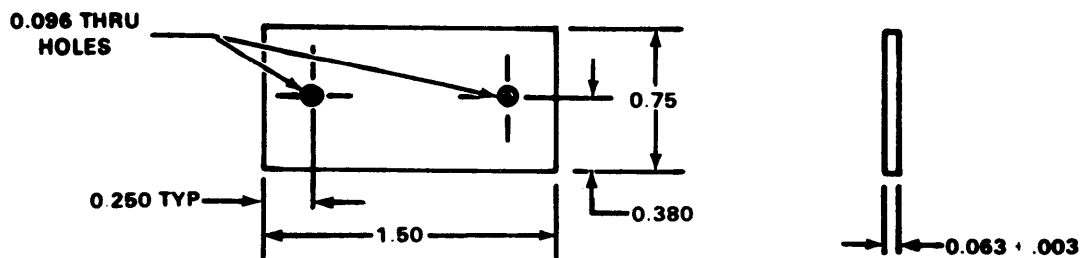
**Figure D-230.** Part Number BL8515 FMC08484 Retainer, Rectifier Bracket  
 Fabricate from: NSN 9535-00-232-0405  
 Material:



Tube Insulating

PART NUMBER	ITEM NAME	FABRICATE FROM NSN	LENGTH
130-005-4-12	TUBE	5970-00-088-2975	6.00
130-005-5-2	TUBE	5970-00-954-1622	1.00
130-005-6-10	TUBE	5970-00-815-1295	5.00
130-005-6-24	TUBE	5970-00-815-1295	12.00
130-005-6-58	TUBE	5970-00-815-1295	29.00
130-005-7-4	TUBE	5970-00-954-1624	2.00
130-005-7-10	TUBE	5970-00-954-1624	5.00
130-005-7-26	TUBE	5970-00-954-1624	13.00
130-005-7-50	TUBE	5970-00-954-1624	25.00
130-005-7C4	TUBE	5970-00-740-2971	2.00
130-005-8-4	TUBE	5970-00-812-2967	2.00
130-005-9-6	TUBE	5970-00-914-3118	3.00

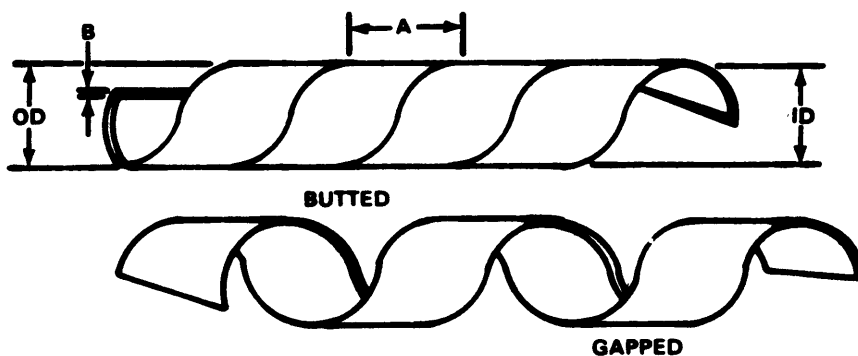
Figure D-232.



**NOTES:**

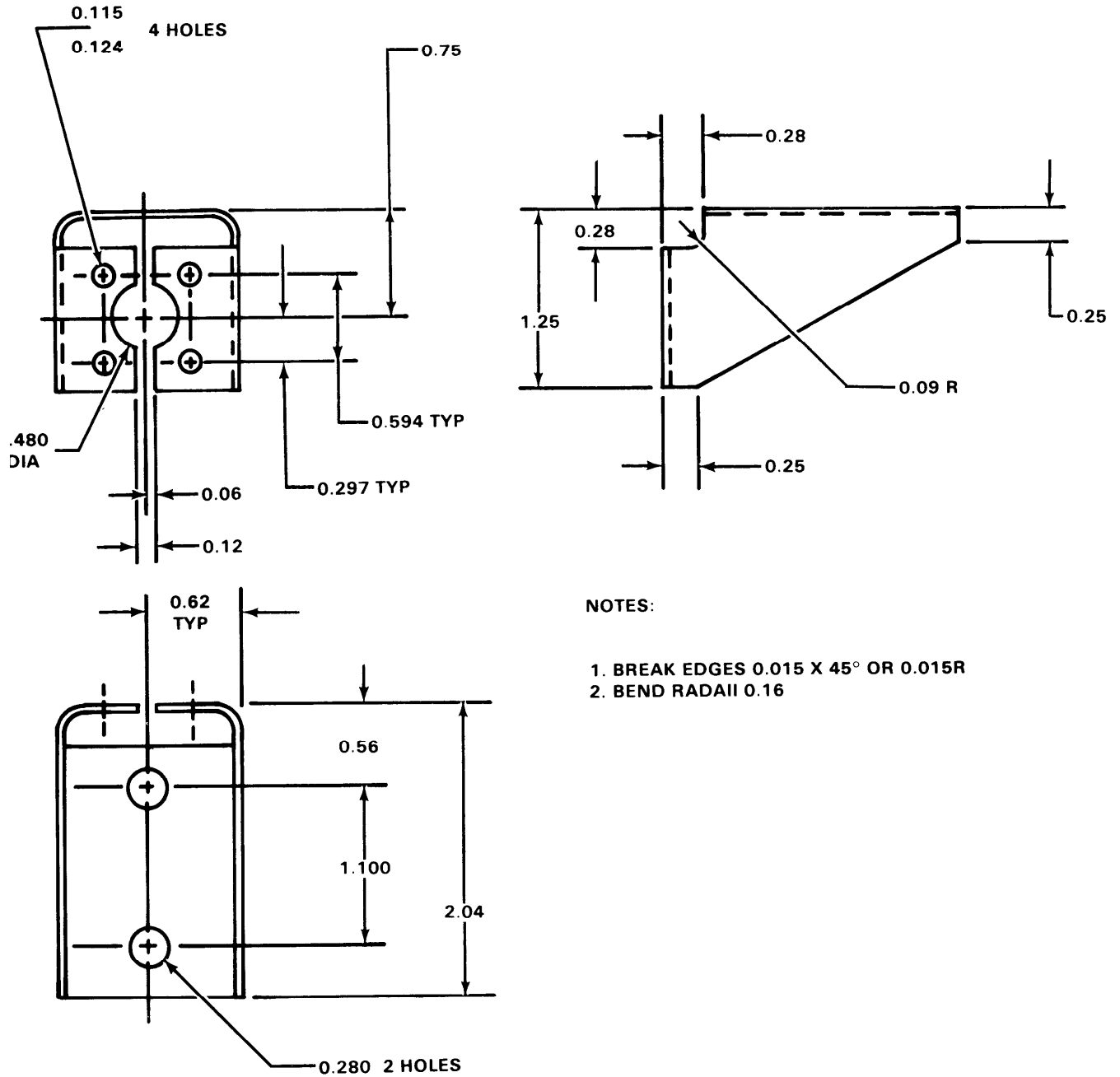
1. PART TO BE LEGIBLY MARKED WITH BHT PART NUMBER.
2. PRODUCT OF THE POLYMER CORP., READING PA. CODE IDENT # 83616.
3. PART SHALL BE FREE OF ALL SHARP EDGES AND SHARP CORNERS.
4. MATERIAL: NYLATRON GS

Figure D-233. Part Number 120-069-1 STRIP – ANTICHAFFING  
 Fabricate from: NSN 9330-00-143-8604  
 Material: Plastic Sheet 0.063 Inch Thick, 0.75 Inch Wide, 1.5 Inch Long



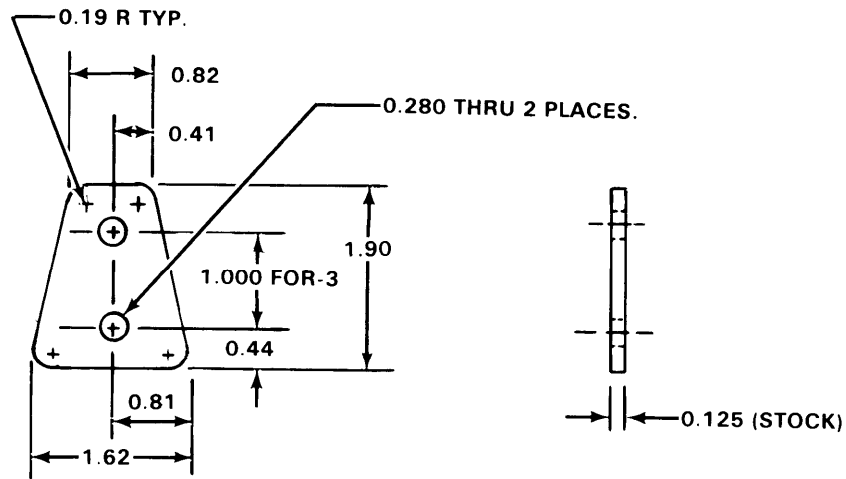
PART NUMBER	ID	OD	A	B	LENGTH IN INCHES
120-067B020	0.436	0.500	0.500	0.032	20
120-067B17	0.436	0.500 +0.020	0.500 +0.015	0.032 +0.010	17

Figure D-234. Part Number 120-067B020 SLEEVE – Protective Coil  
 Fabricate from: NSN 4720-00-011-2000  
 Material: Nylon

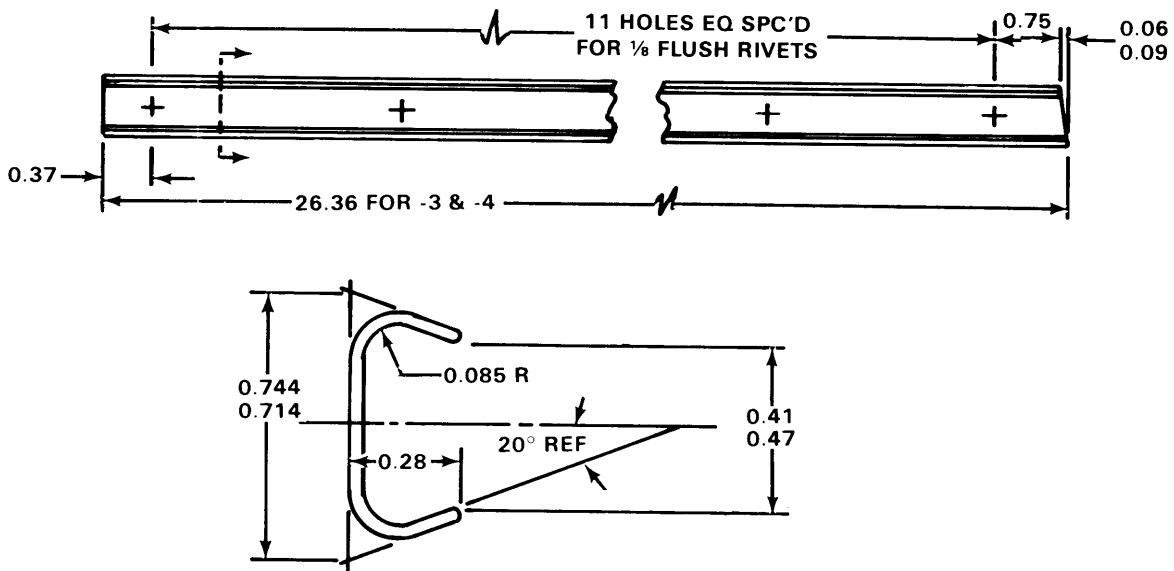


**Figure D-235;** Part Number  
Fabricate from:  
Material:

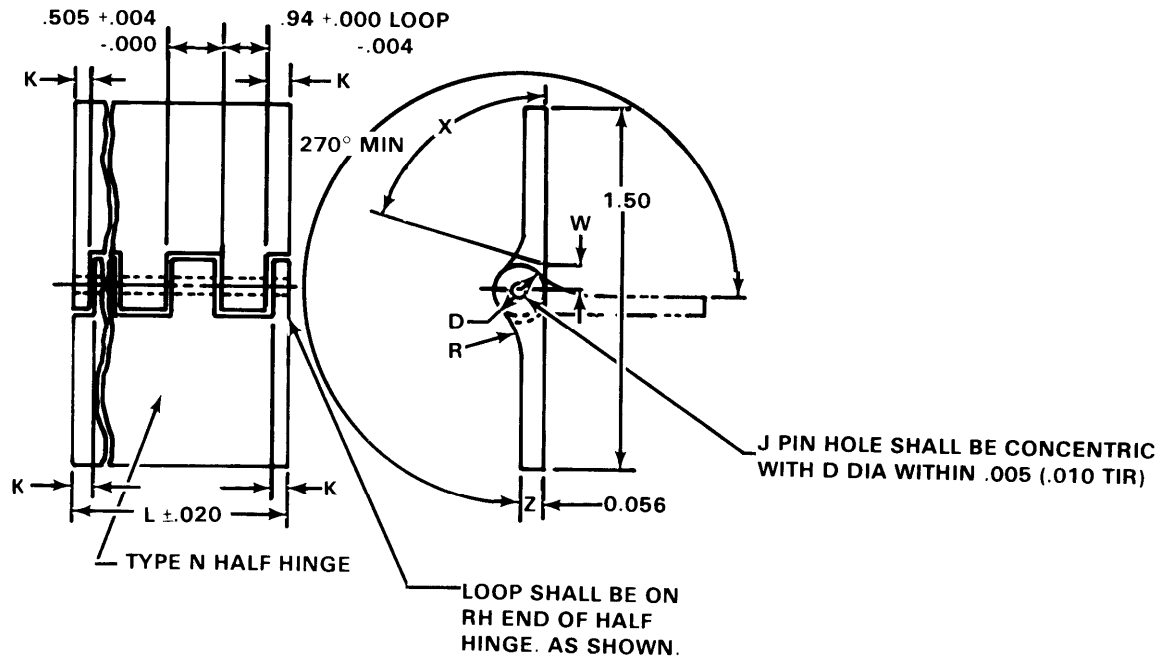
204-011-059-1 BRACKET  
NSN 9536-00-086-9930  
2024 AL ALY SHEET, Federal Specification QQ-A-250/4,  
T3 040 Inch Thick, 2.5 Inch Wide, 4.3 Inch Long



**Figure D-236.** Part Number 204-012-022-3 RETAINER – Weight  
 Fabricate from: NSN 9535-00-232-0479  
 Material: 2024 AL ALY Sheet, Federal Specification QQ-A-250/4, T3,  
 0.125 Inch Thick, 2.2 Inch Wide, 2.4 Inch Long



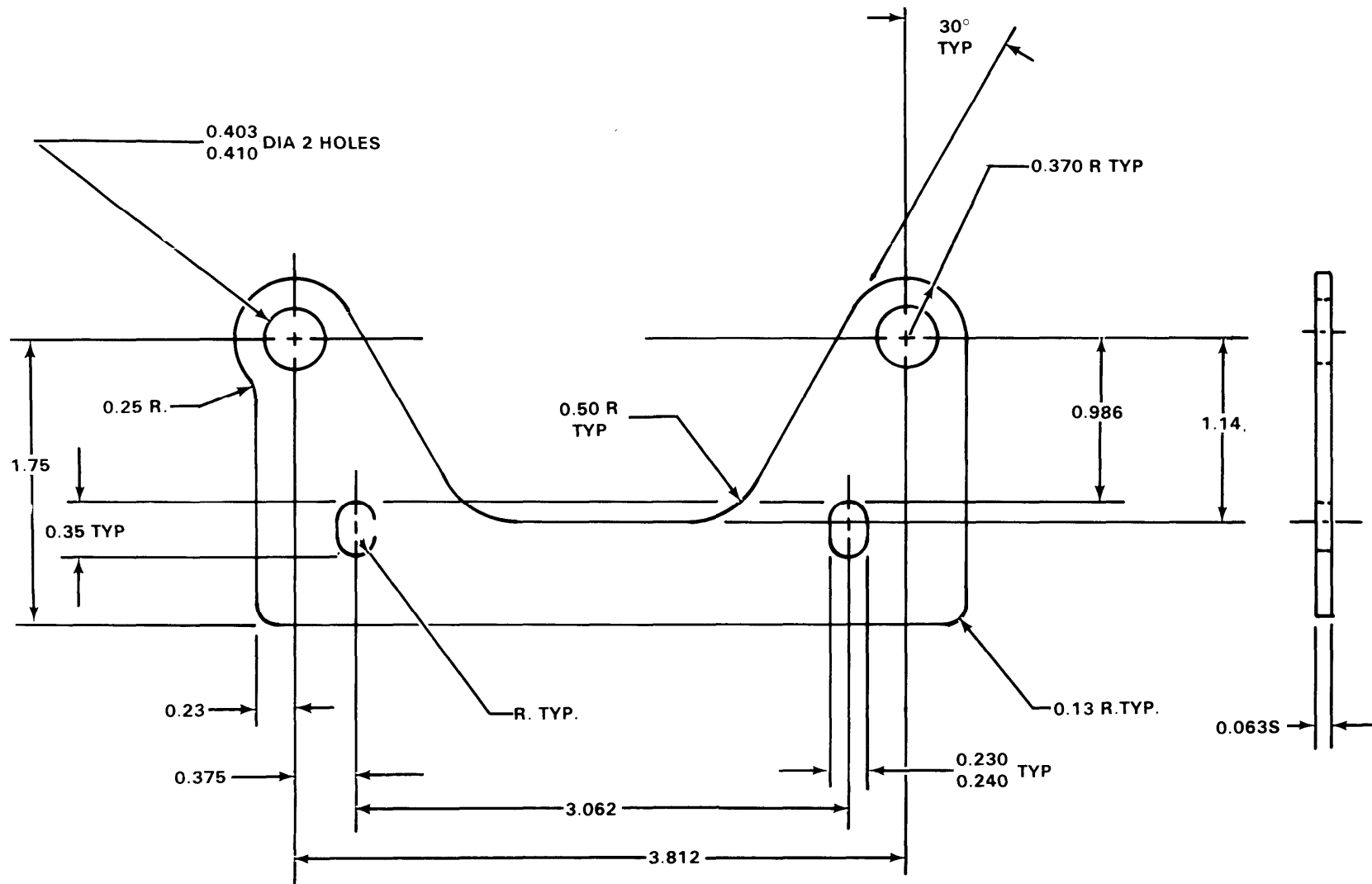
**Figure D-237.** Part Number 204-030-458-4 RETAINER, Window Channel Crew Door  
 Fabricate from: NSN 9535-00-085-4157  
 Material: 2024 AL ALY Sheet, Federal Specification QQ-A-250/5, T-0,  
 0.32 Inch Thick, 1.5 Inch Wide, 27.0 Inch Long



THICKNESS	WIDTH	LENGTH
0.056	1.50	24.00

Figure D-238.

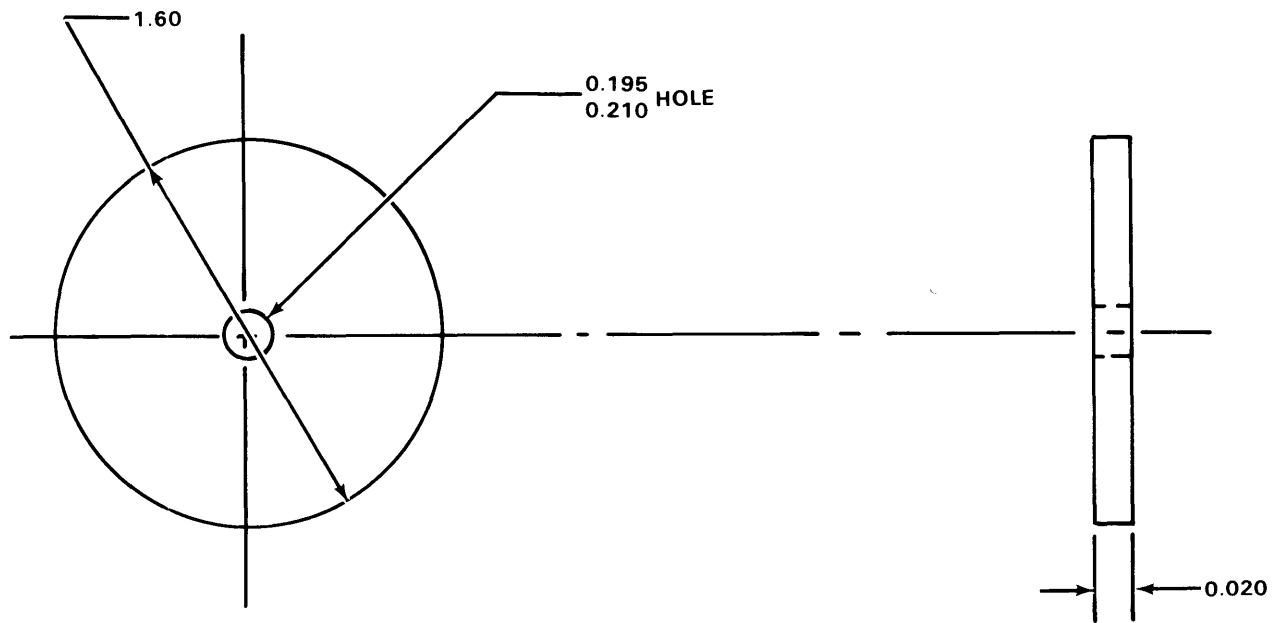
Part Number 204-030-829-16 HINGE HALF  
 204-030-829-27 HINGE HALF  
 Fabricate from: NSN 5340-00-949-8274  
 Material: Leaf, Butt Hinge AL ALY Anodized, 0.056 Inch Thick, 0.495 Inch Wide  
 Half Hinge, 1.50 Inch Total Width Make From MS20001P4-2400-Length 24.00



NOTES:

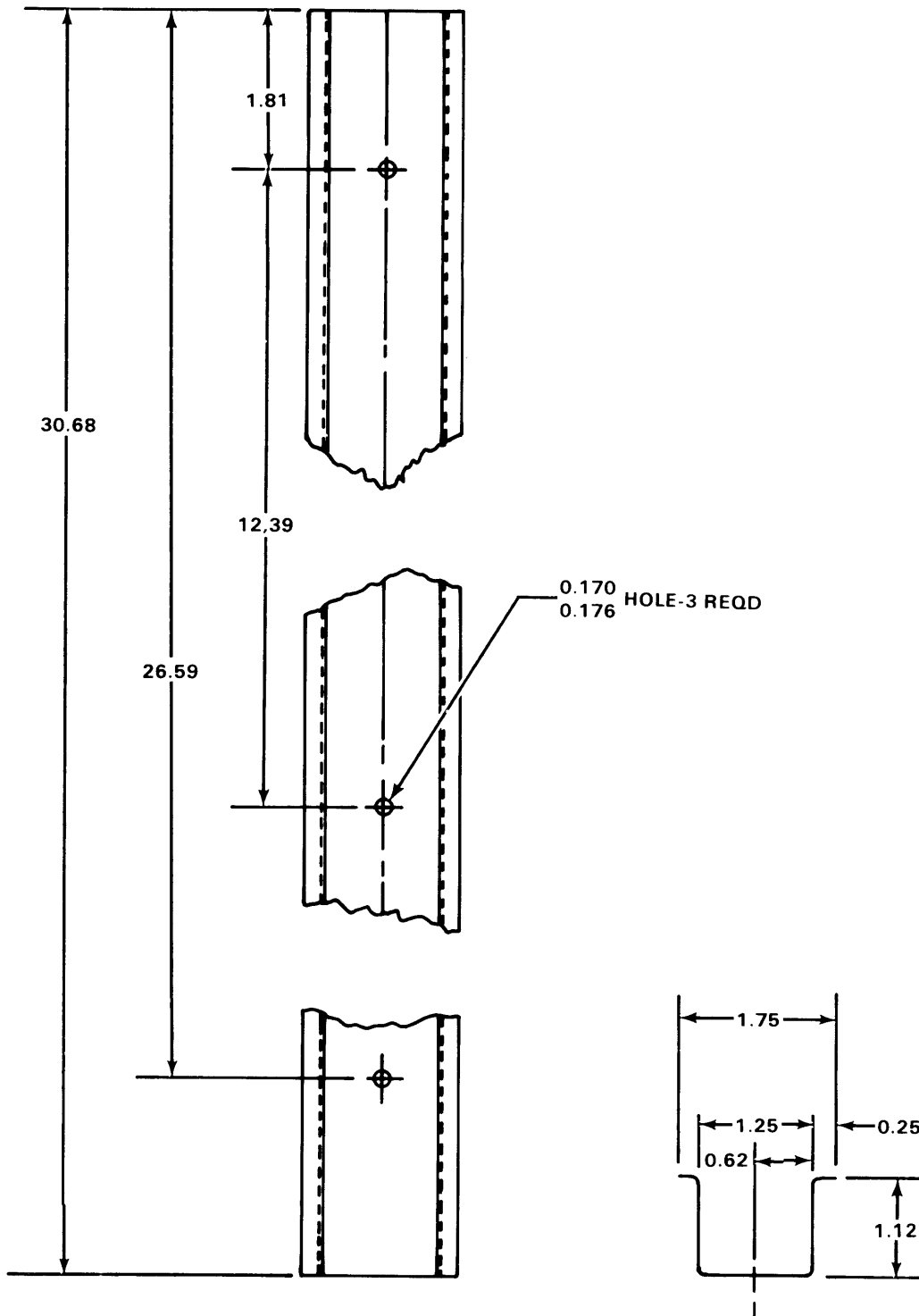
1. BREAK SHARP EDGES 0.015R or 0.015, 40°-50° CHAMP

**Figure D-239.** Part Number 204-040-848-1 BRACKET  
 Fabricate from: NSN 9636-00-554-1417  
 Material: 2024 AL ALY SHEET, Federal Specification QQ-A-250/5 T-3,  
 0.063 Inch Thick, 2.6 Inches Wide, 5.0 Inches Long

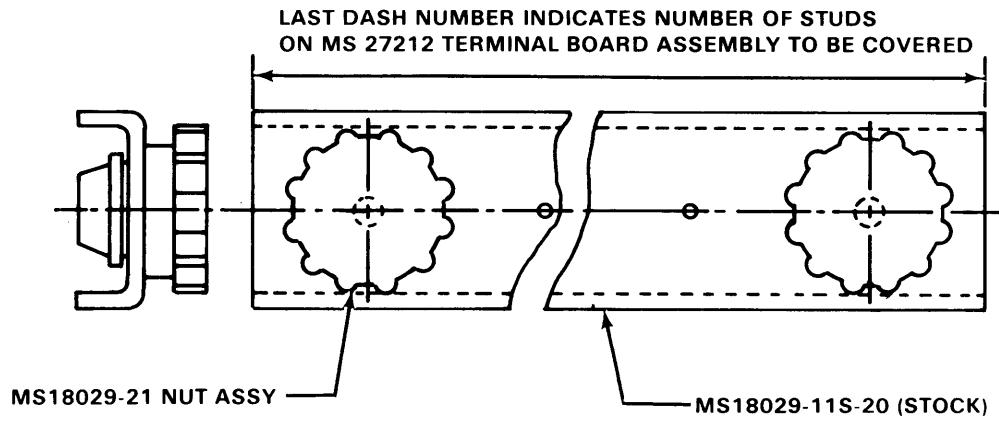


**Figure D-240.** Part Number 204-060-224-9 PLATE  
 Fabricate from: NSN 9535-00-084-4484  
 Material: 2024 AL ALY SHEET, Federal Specification QQ-A-250/5, T-3,  
 0.020 Inch Thick, 2.1 Inches Wide, 2.1 Inches Long

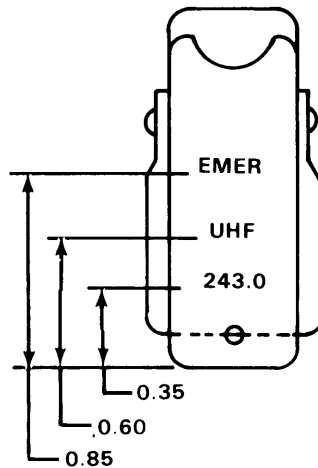




**Figure D-241.** Part Number 204-030-665-11 CHANNEL  
 Fabricate from: NSN 9635-00-167-2174  
 Material: 2024 AL ALY SHEET, Federal Specification QQ-A-250/5, T-3,  
 0.016 Inch Thick, 4.3 Inches Wide, 31.0 Inches Long



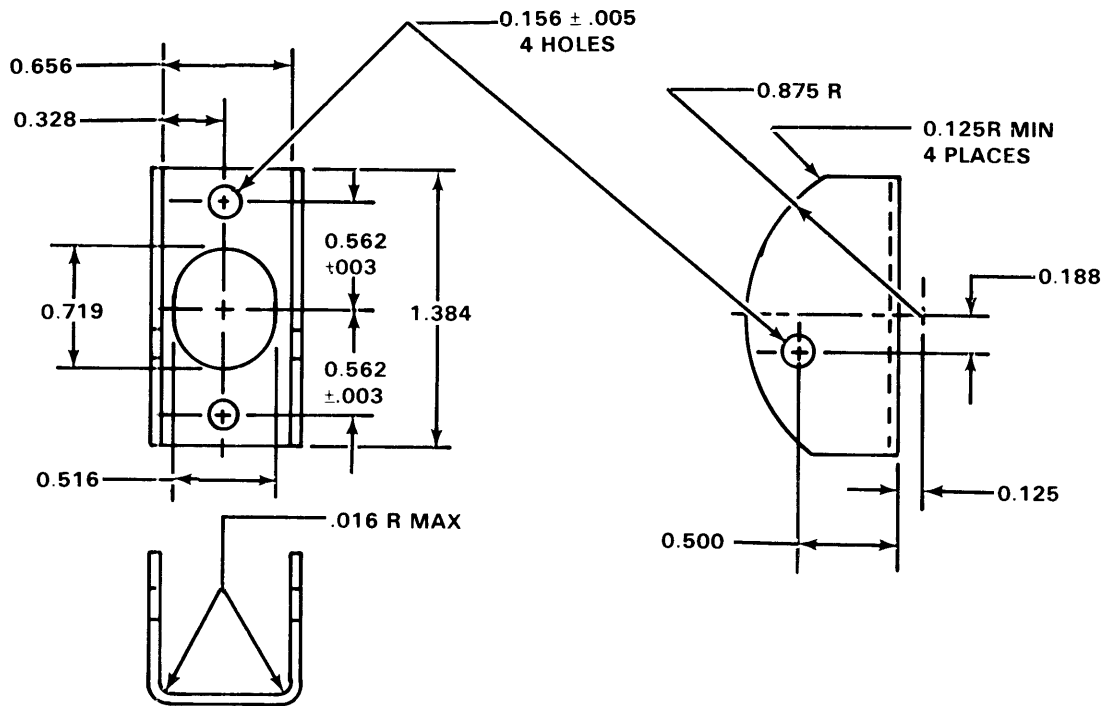
**Figure D-242.** Part Number MS18029-1S1  
 MS18029-1S10  
 MS18029-1S14  
 MS18029-1S15  
 Terminal Board Cover  
 Fabricate from: NSN 5940-00-082-4642, MS18029-11S20 COVER,  
 NSN 5940-00-907-5939, MS18029-21NUT ASSY.



**NOTES:**

1. EACH LINE OF LETTERING SHALL BE HORIZONTALLY CENTERED ON THE SWITCH GUARD FACE.
2. LETTERS SHALL BE ENGRAVED .16 HEIGHT, AND FILLED WITH WHITE MONOFIL.
3. MAKE FROM MS25224-1 SWITCH GUARD.
4. IDENTIFY WITH BHT PART NO.

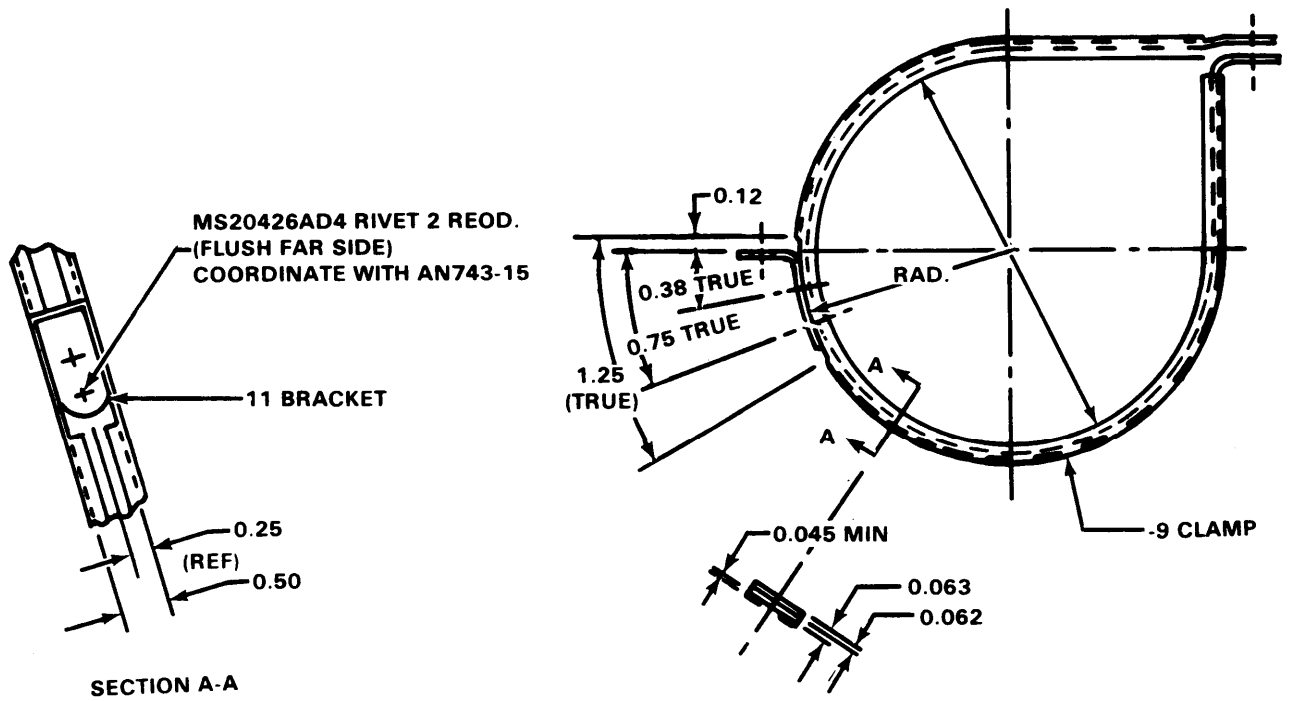
**Figure D-243.** Part Number 90-045-5 GUARD-SWITCH Engraved Lettering  
 Fabricate from: NSN 5930-00-615-6731, MS25224-1 GUARD SWITCH



**NOTES:**

1. MAY BE MADE FROM MS25221-1 GUARD
2. PART TO BE SMOOTH AND FREE OF BURRS
3. FINISH GUARD WITH INSTRUMENT BLACK ENAMEL, MIL-E-5557 COLOR 27038, FED STD 595.
4. IDENTIFY WITH BHT PART NO.

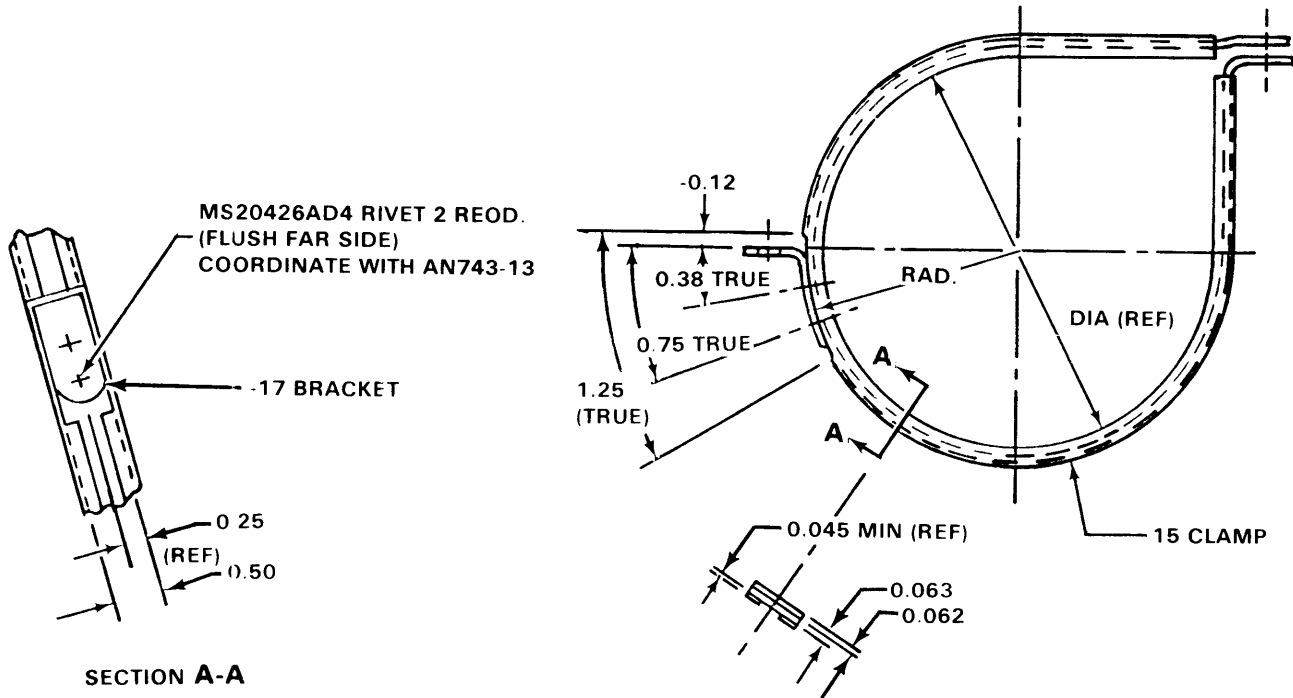
**Figure D-244.** Part Number: 90-047-1 GUARD-SWITCH, Special  
 Fabricate from: NSN 5930-00-990-5766,  
 MS 25221-1 GUARD



**NOTES:**

1. PART NO. 204-070-048-9 CLAMP—MAY BE MADE FROM ALTERED MS219190G48 CLAMP NSN 5340-00-514-3017
2. PART NO. 204-070-048-11 BRACKET—MAY BE MADE FROM ALTERED AN743-13 BRACKET NSN 5340-00-721-8182
3. RIVET THE ALTERED AN743-13 BRACKET TO CLAMP WITH MS20426AD4 RIVETS

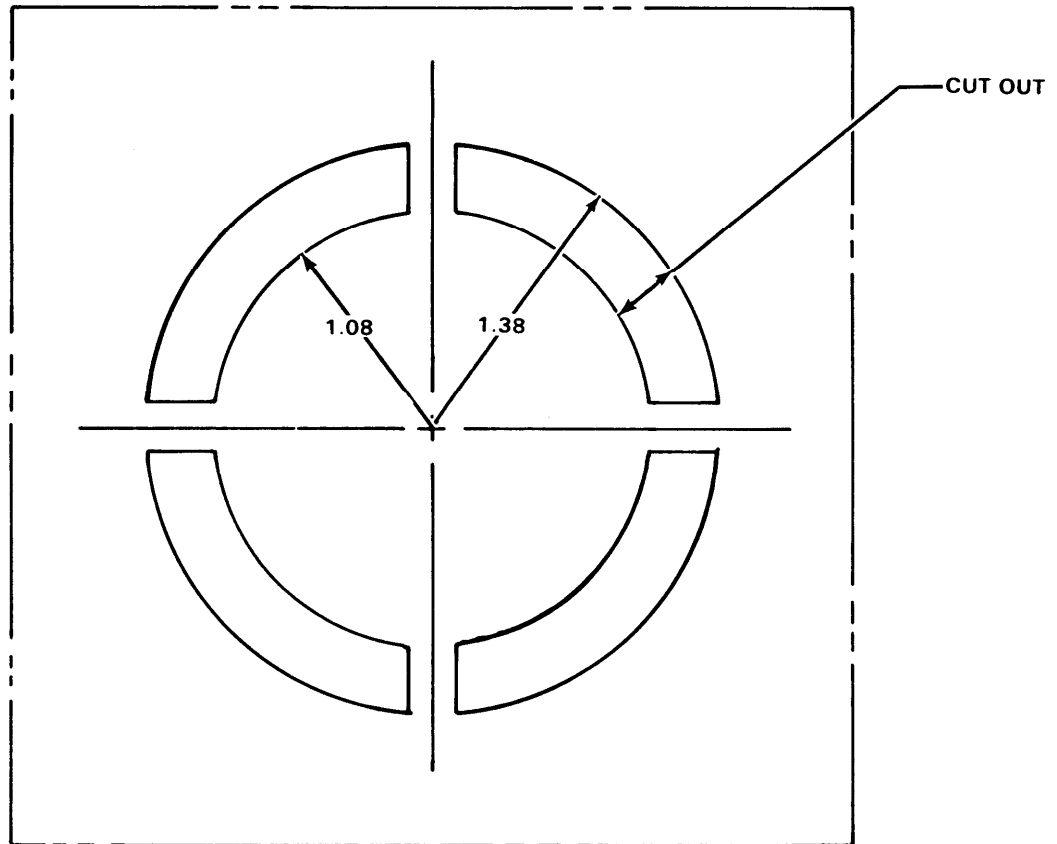
Figure D-245. Part Number: 204-070-048-7 CLAMP Assembly  
Fabricate from: NSN 5340-00-514-3017  
NSN 5340-00-721-8182



**NOTES:**

1. PART NO. 204-070-048-15 CLAMP — MAY BE MADE FROM ALTERED MS21919DG32  
NSN 5340-00-265-6797
2. PART NO. 204-070-048-17 BRACKET MAY BE MADE FROM ALTERED AN743-13 BRACKET  
NSN 5340-00-721-8182
3. RIVET THE ALTERED AN743-13 BRACKET TO CLAMP WITH MS20426AD4 RIVETS

**Figure D-246.** Part Number 204-070-048-13 CLAMP ASSEMBLY  
Fabricate from: NSN 5340-00-265-6797  
NSN 5340-00-721-8182

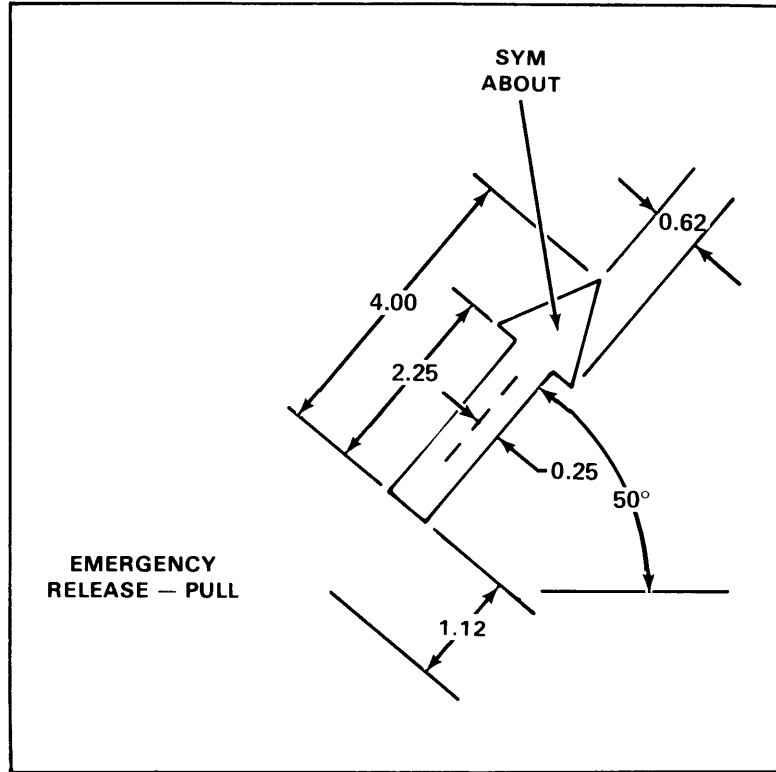


**NOTES:**

1. LETTERING TO BE SPACED APPROX. AS SHOWN

**Figure D-247.**

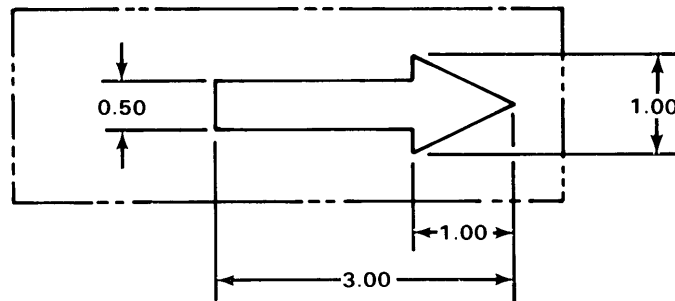
Part Number	204-070-806 -3 STENCIL
Fabricate from:	9310-00-265-6769
Material:	Stencil, Board Federal Specification U-U-625 TYPE 2, GRADE 1



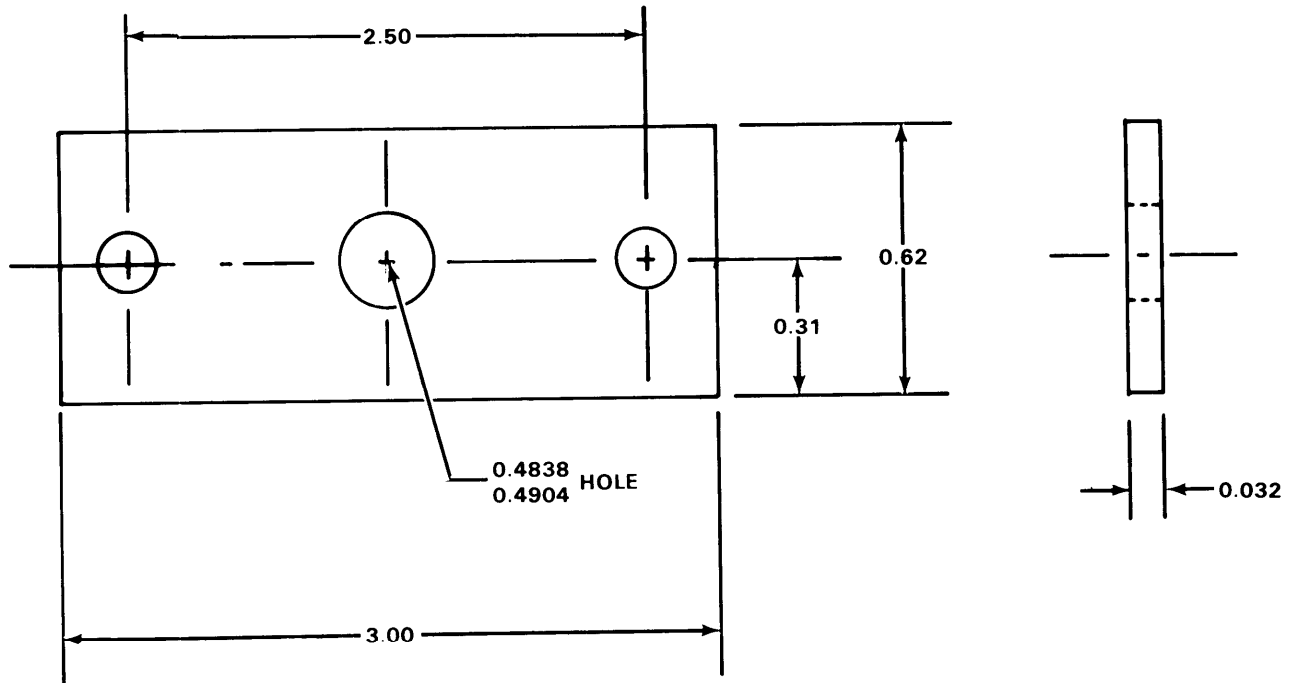
NOTES:

1. LETTERS TO BE 1.0 INCH HIGH SPACES APPROX. AS SHOWN

**Figure D-248.** Part Number 204-070-812-1 STENCIL  
 Fabricate from: NSN 9310-00-265-6797  
 Material: Stencil Board Federal Standard UU-S-625 TYPE 2, Grade 1

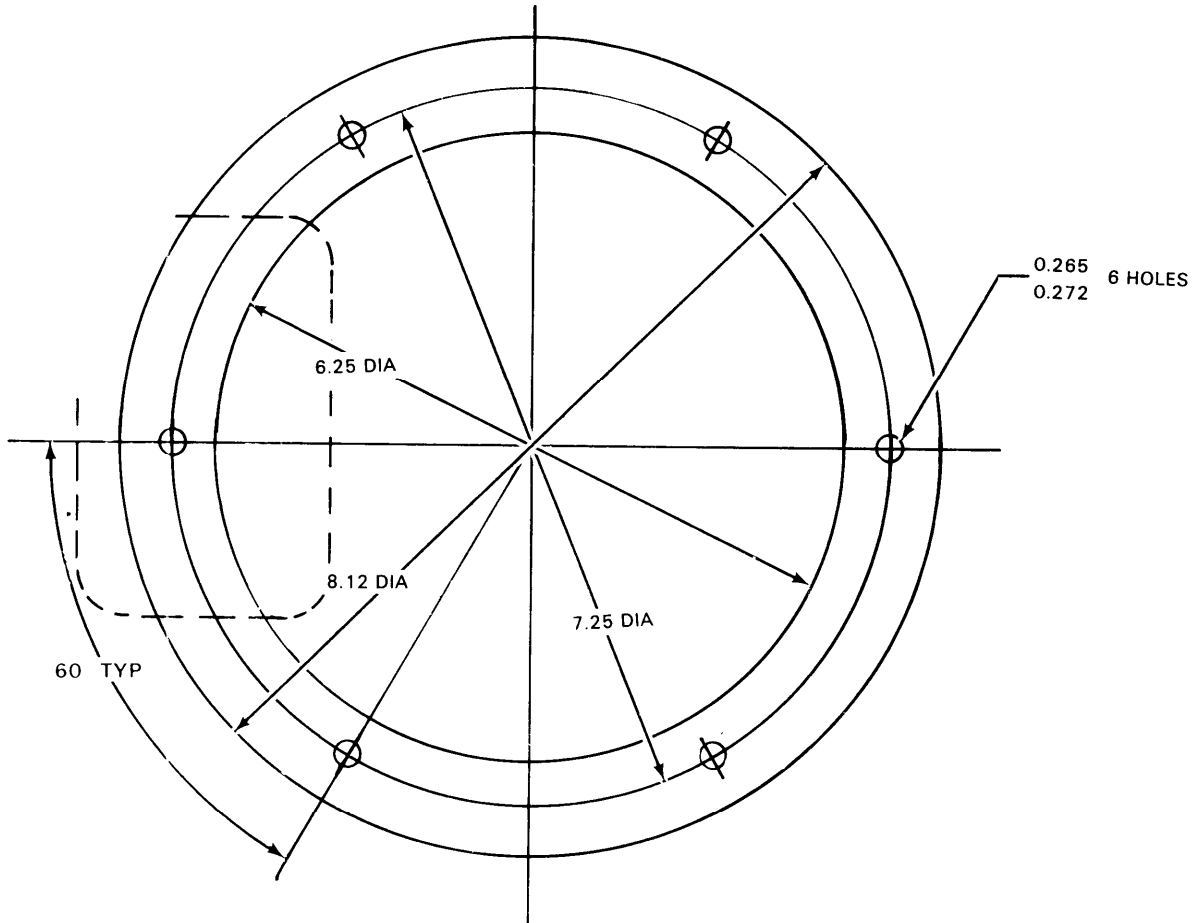


**Figure D-249.** Part Number 204-070 -845-1 STENCIL  
 Fabricate from: NSN 9310-00-265-6797  
 Material: Stencil, Board, Federal Specifications UU-S-625, Type 2, Grade 1



**Figure D-250.** Part Number 204-070-848-3 RETAINER  
 Fabricate from: NSN 9535-00-232-0565  
 Material: 2024 AL ALY SHEET Federal Specification QQ-A-250/5, 0.032 Inch Thick,  
 1.0 Inch Wide, 3.5 Inches Long

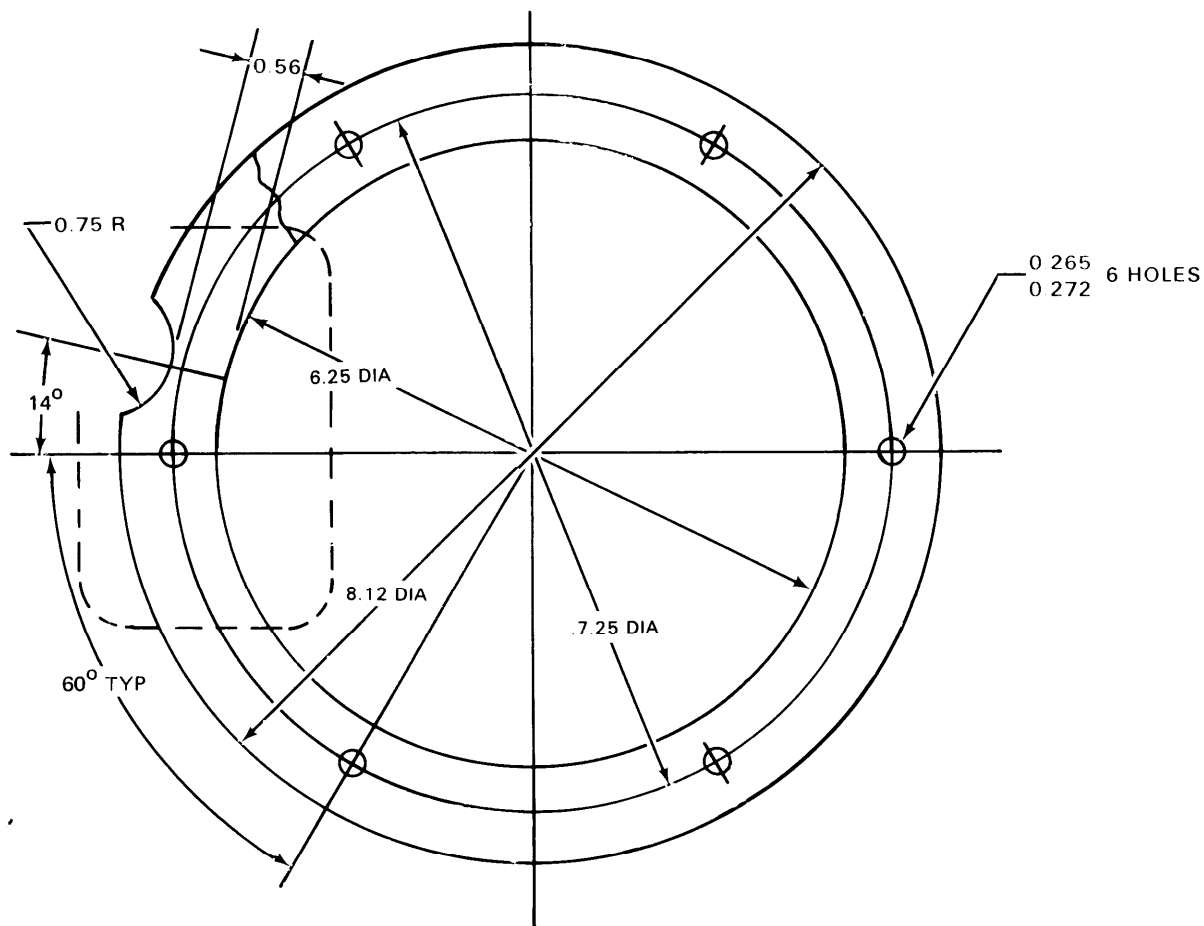




- NOTES.
1. MARK PER PBS FW-B-4050
  2. PURCHASE FROM JOHNS-MANVILLE PRODUCTS NEW YORK, N.Y.  
CODE IDENT # 92798

THICKNESS	SIZE	STYLE
3 64 INCH	9.0 x 9.0	89

**Figure D-251.** Part Number 204-072-258-1 GASKET  
 Fabricate from: NSN 5330-00-938-1719  
 Material: Asbestos

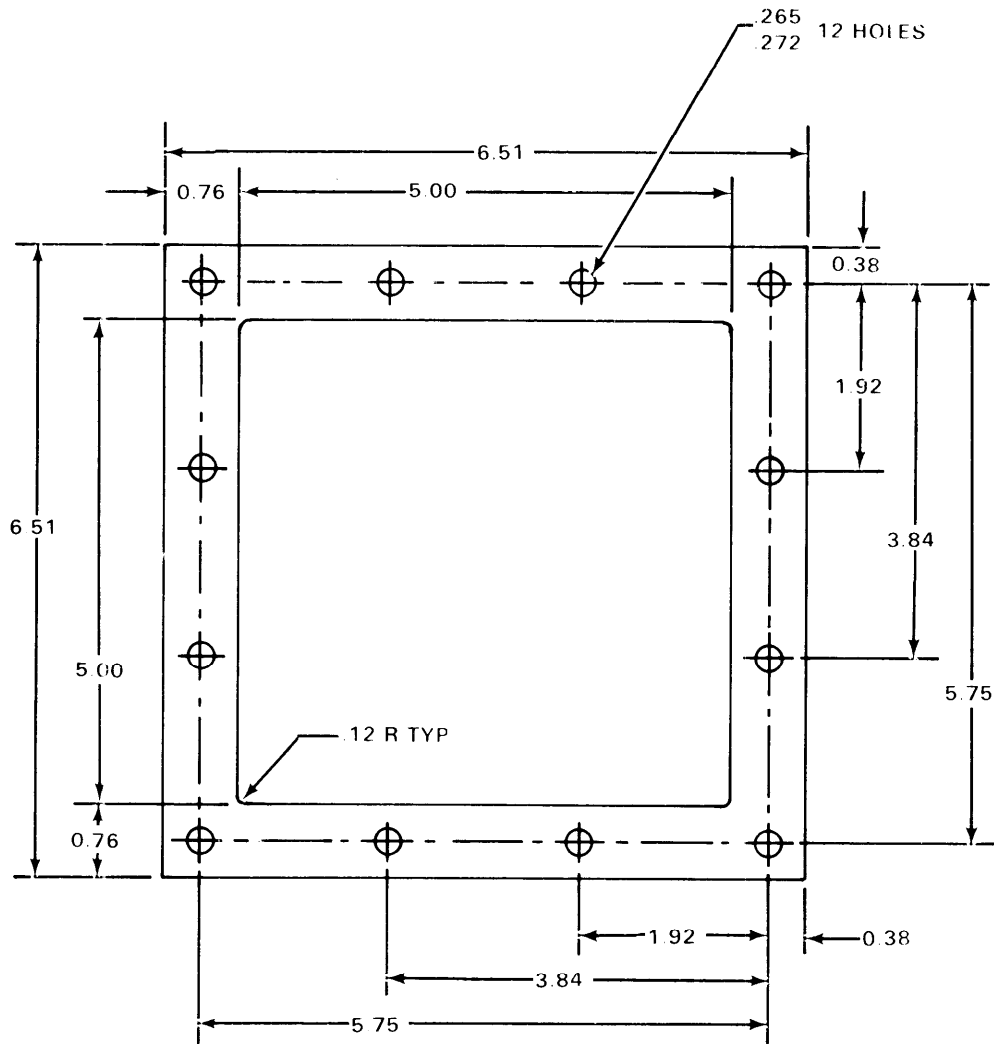


NOTES:

1. MATERIAL MAY BE PURCHASED FROM JOHNS-MANVILLE PRODUCTS; NEW YORK, N. Y. CODE IDENT 92798
2. SPECIAL ASBESTOS MATERIAL NO

THICKNESS	SIZE	STYLE
3 64 INCH	9 0 · 9 0	89

**Figure D-252.** Part Number 204-072 -258-3 GASKET  
 Fabricate from: NSN 5330-00-938-1719  
 Material: See notes

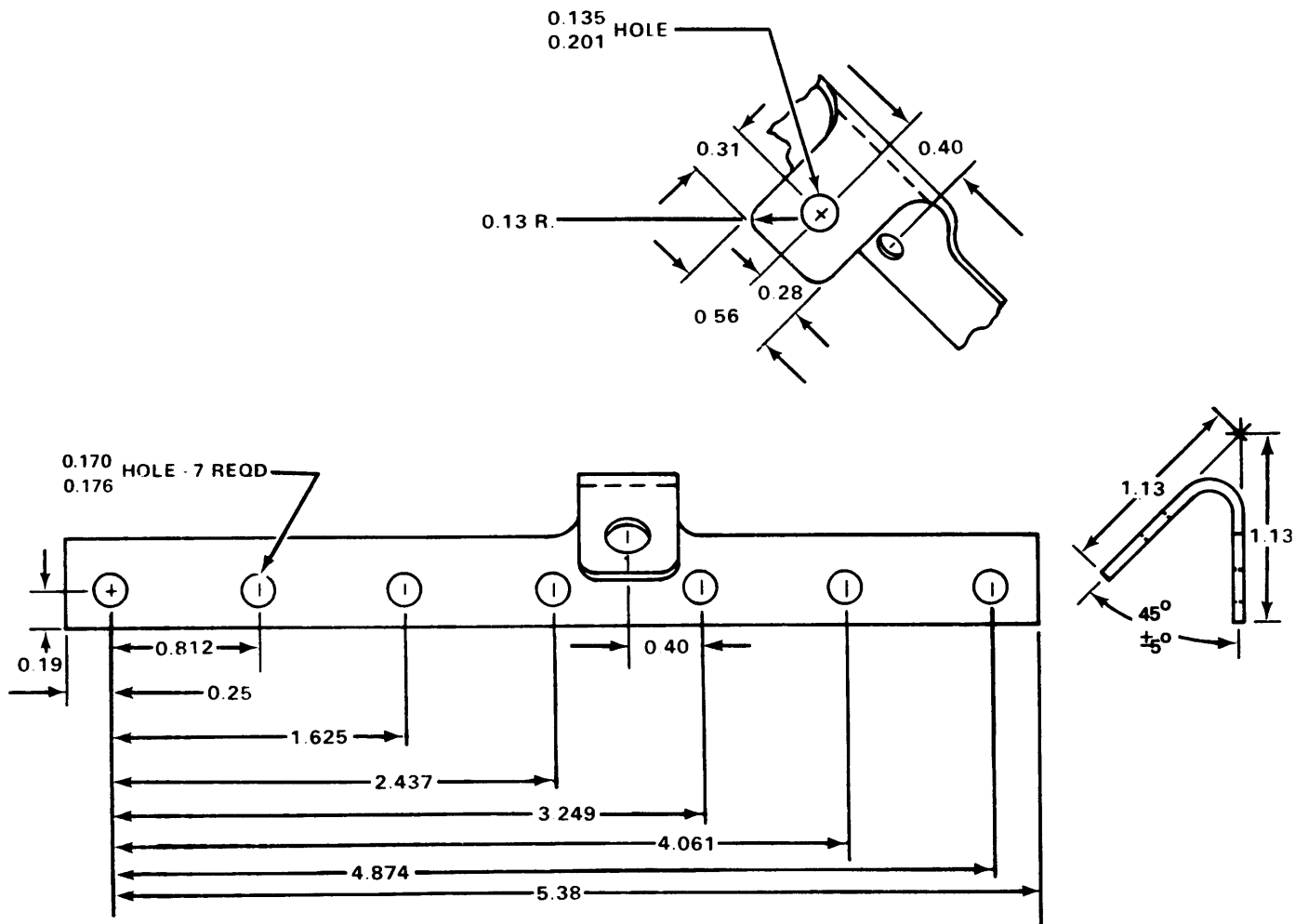


NOTES:

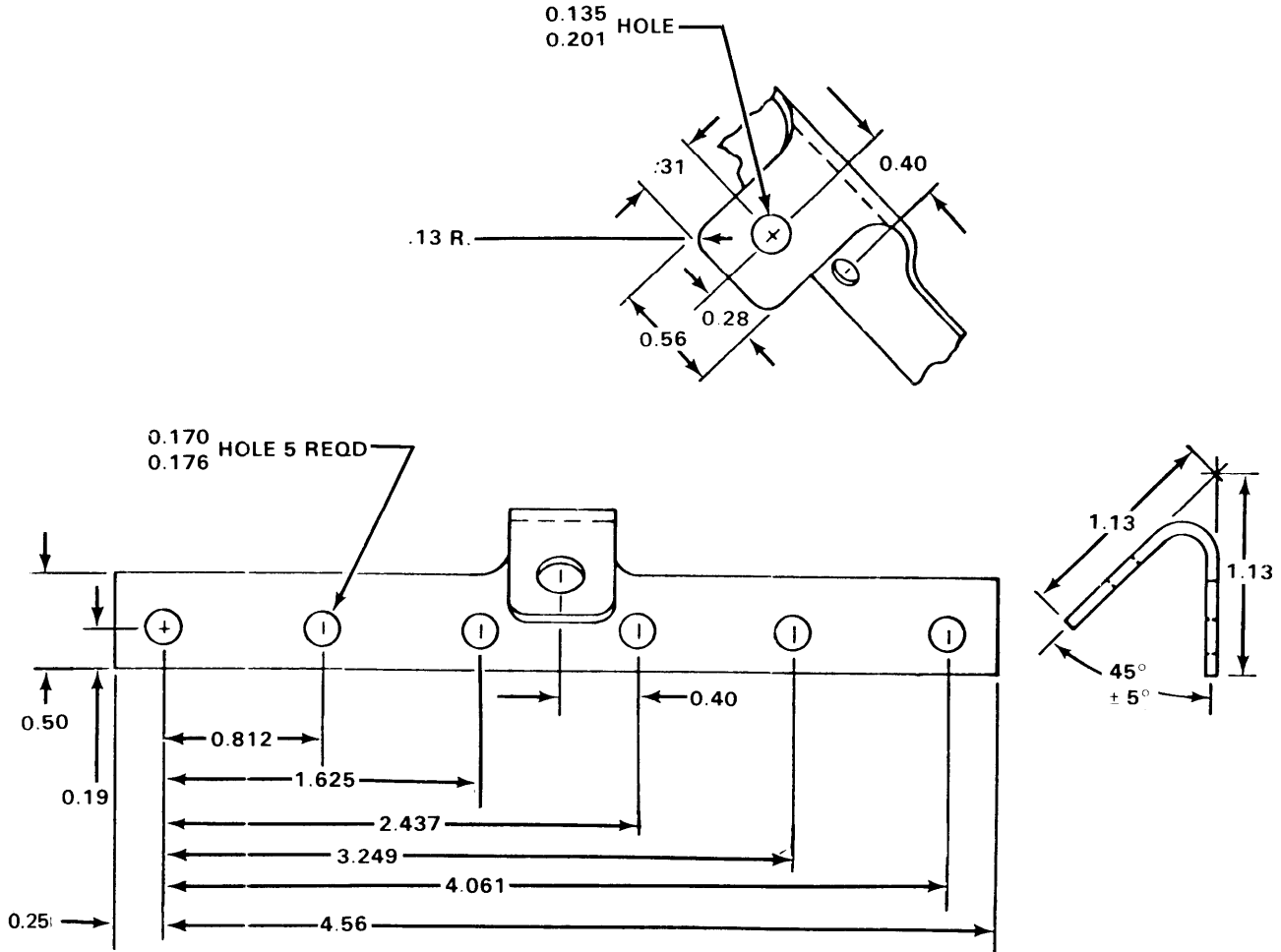
1. PURCHASE FROM JOHNS-MANVILLE PRODUCTS NEW YORK, N.Y.  
CODE IDENT # 92798
2. SPECIAL ASBESTOS MATERIAL NO NSN AVAILABLE

THICKNESS	SIZE	STYLE
3/64 INCH	7.0 · 7.0	89

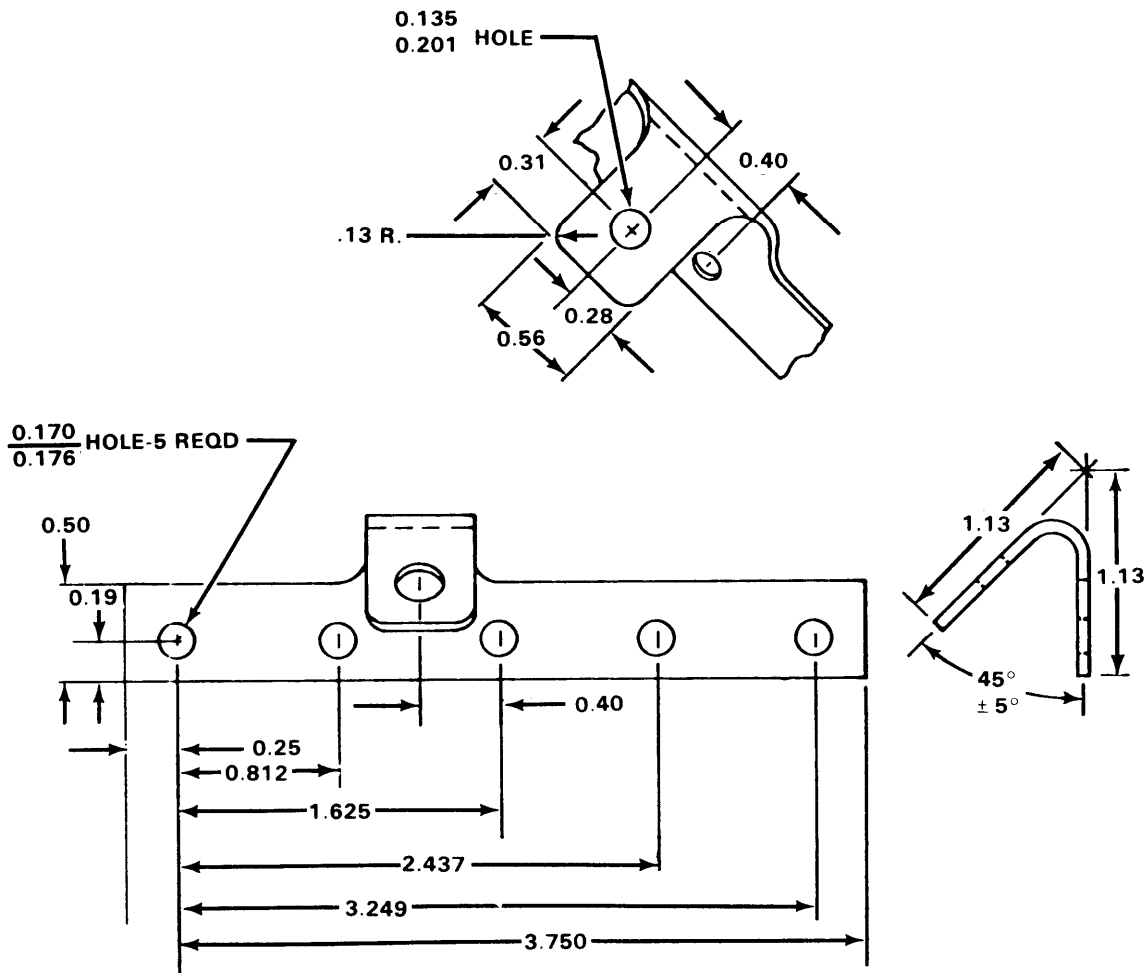
**Figure D-253.** Part Number 204-072-259-1 GASKET  
Fabricate from: NSN 5330-00-936-2420



**Figure D-254.** Part Number 204-076-264-1 BUS BAR  
 Fabricate from: NSN 6150-00-225-0267  
 Material: Copper Sheet, Federal Specifications QQ-C-576, ANNEALED  
 0.063 Inch Thick, 2.0 Inches Wide, 5.8 Inches Long



**Figure D-255.** Part Number 204-076-264-3 BUS BAR  
 Fabricate from: NSN 6150-00-226-0267  
 Material: Copper Sheet, Federal Specifications QQ-C-576, ANNEALED  
 0.063 Inch Thick, 2.0 Inches Wide, 6.0 Inches Long



**Figure D-256.** Part Number: 204-075-264-5 BUS BAR  
 Fabricate from: NSN 6150-00-225-0267  
 Material: Copper Sheet, Federal Specification QQ-C-576, Annealed, 0.063 Inch Thick, 2.0 Inches Wide, 4.3 Inches Long

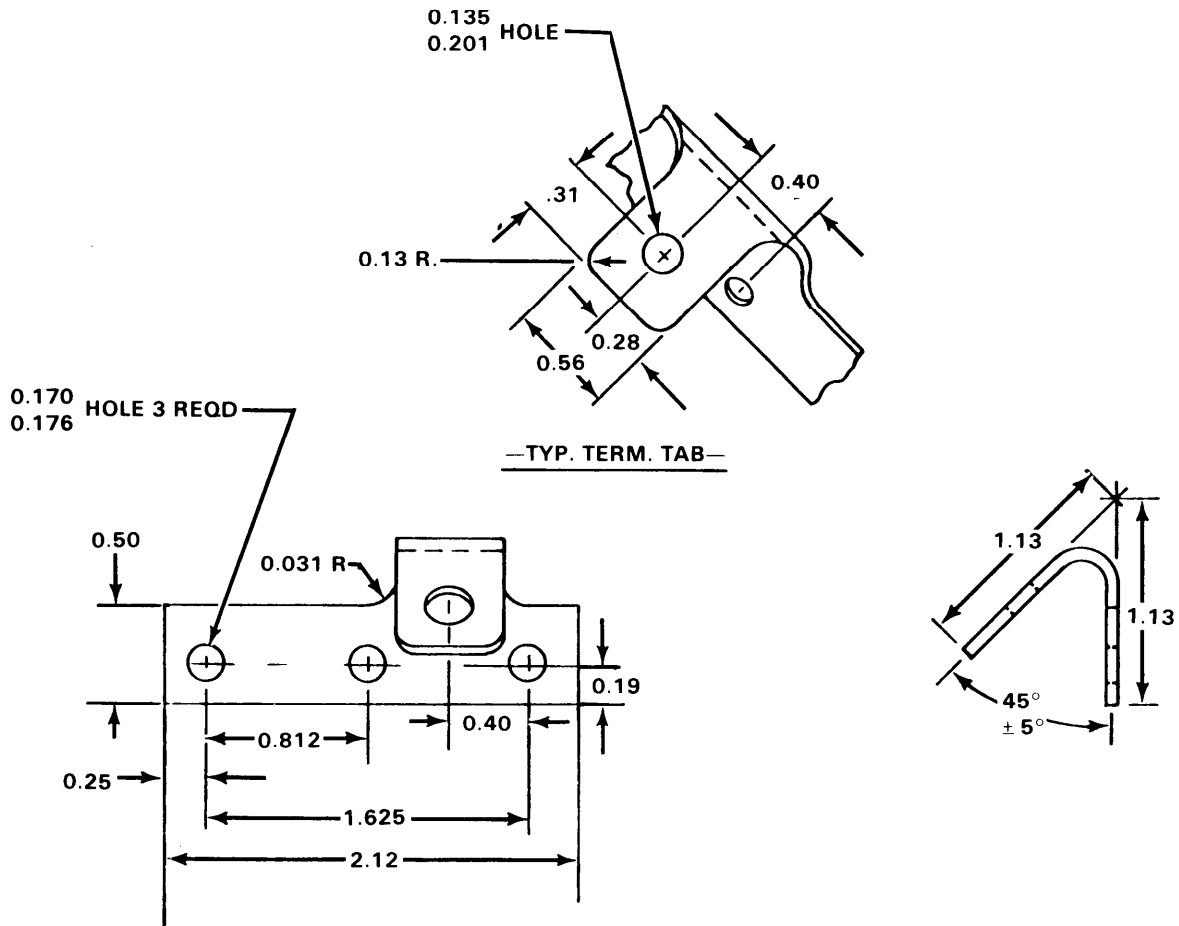


Figure D-257.

Part Number  
Fabricate from:  
Material:

204-075-264-9 BUS BAR  
NSN 6150-00-225-0267  
Copper Sheet, Federal Specification QQ-C-567, Annealed,  
0.063 Inch Thick, 2.0 Inches Wide, 2.6 Inches Long

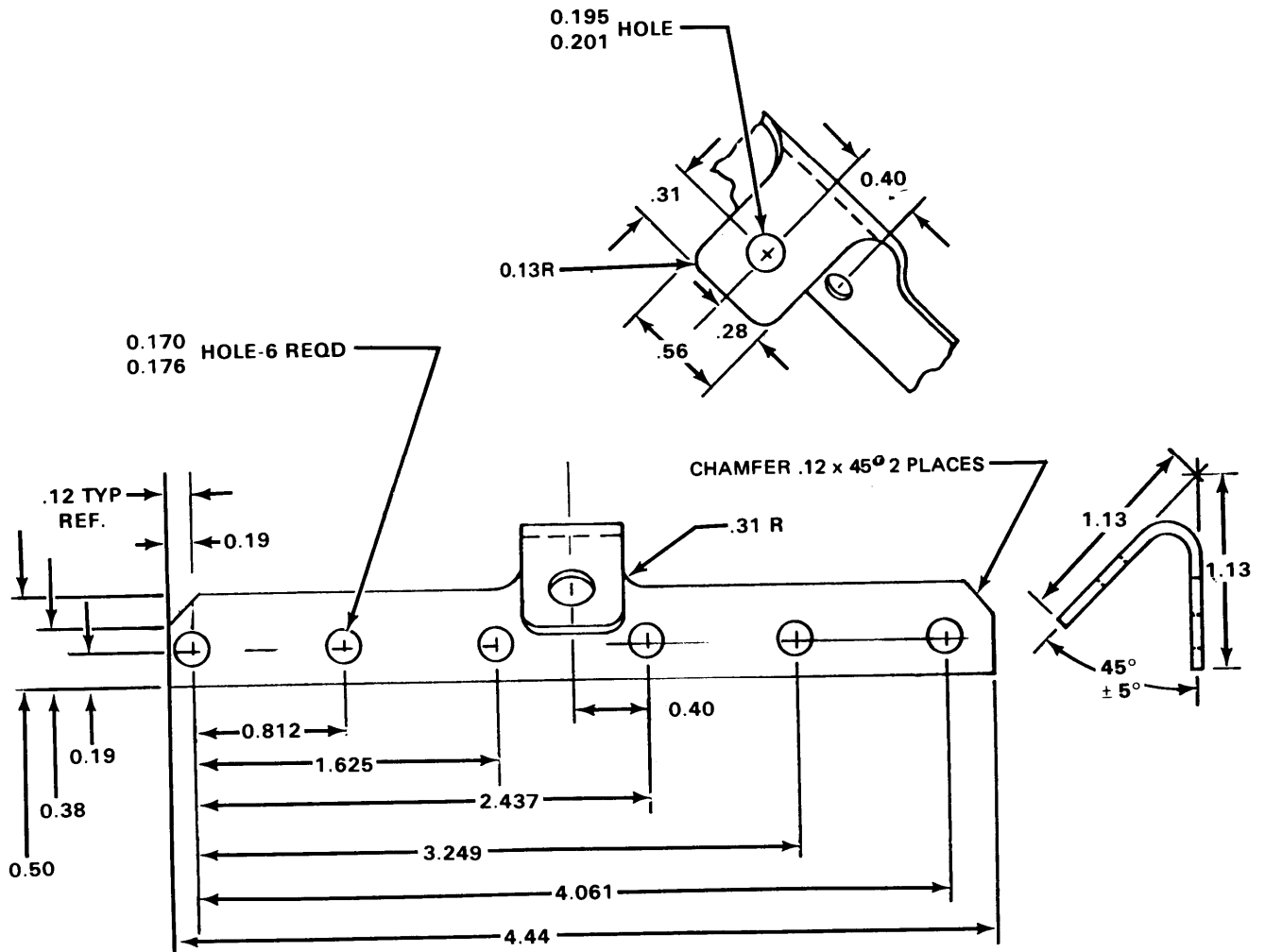
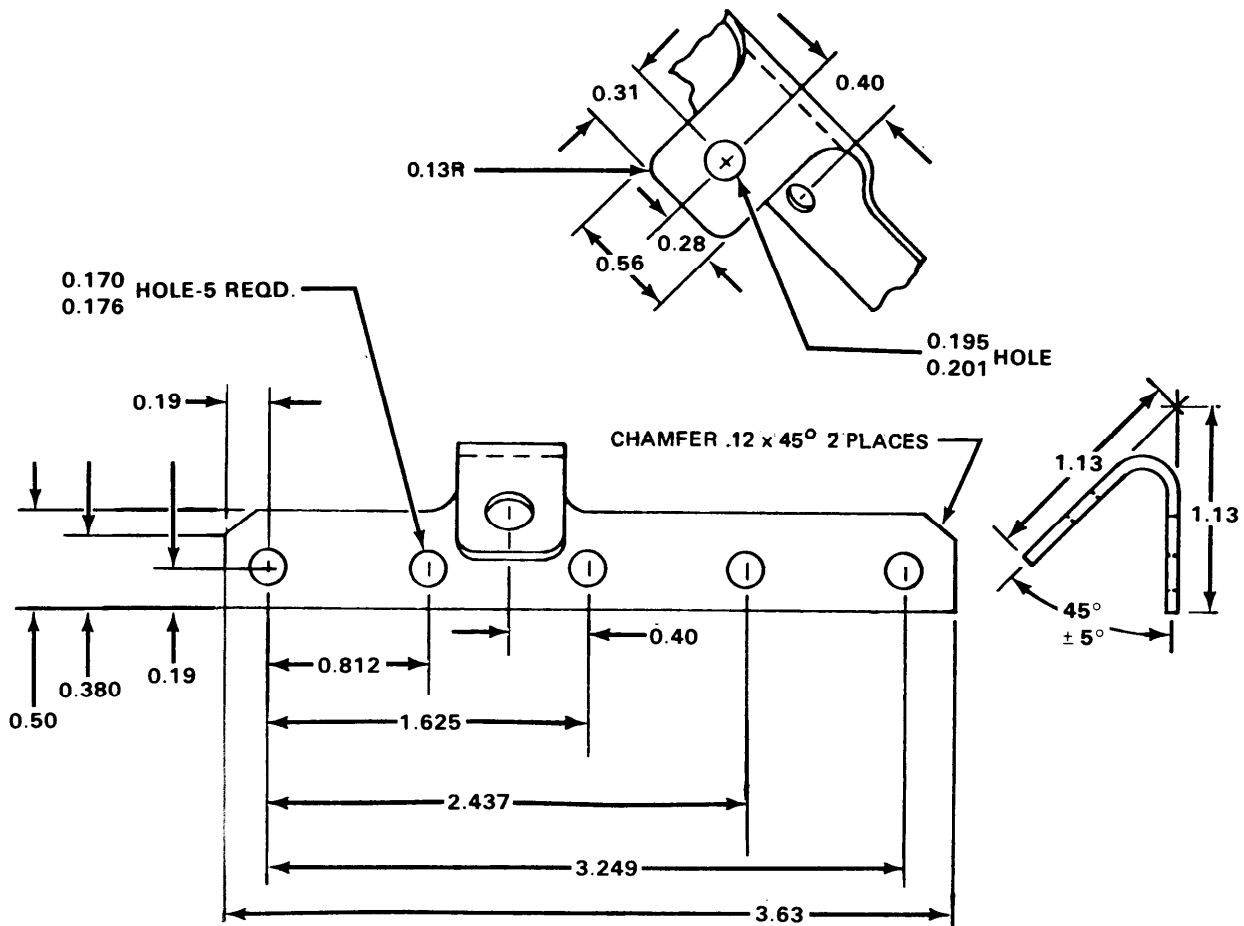


Figure D-258.

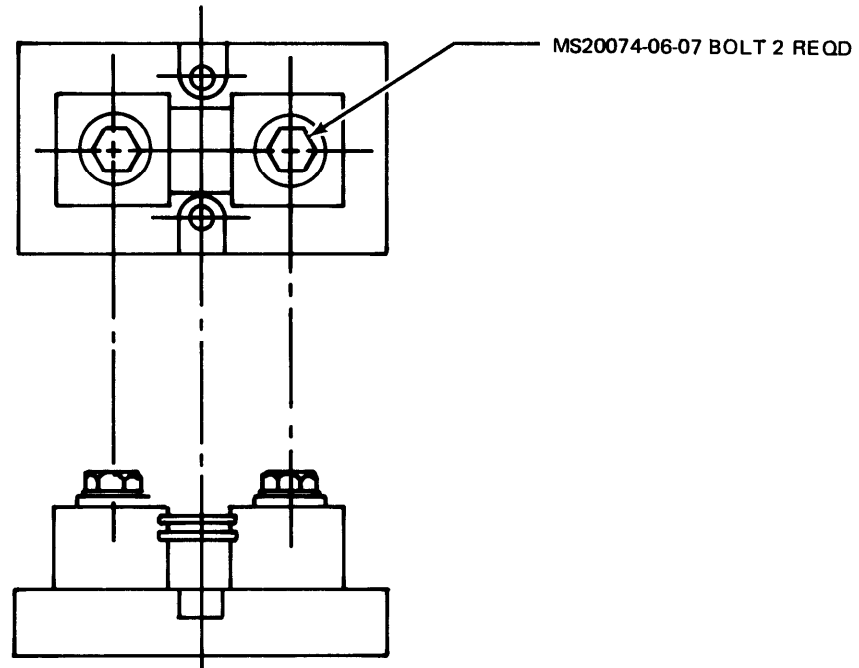
Part Number  
Fabricate from:  
Material:

204-075-230-3 BUS BAR  
NSN 6150-00-225-0267  
Copper Sheet, Federal Specification QQ-C-576, Annealed,  
0.063 Inch Thick, 2.7 Inch Wide, 5.0 Inch Long





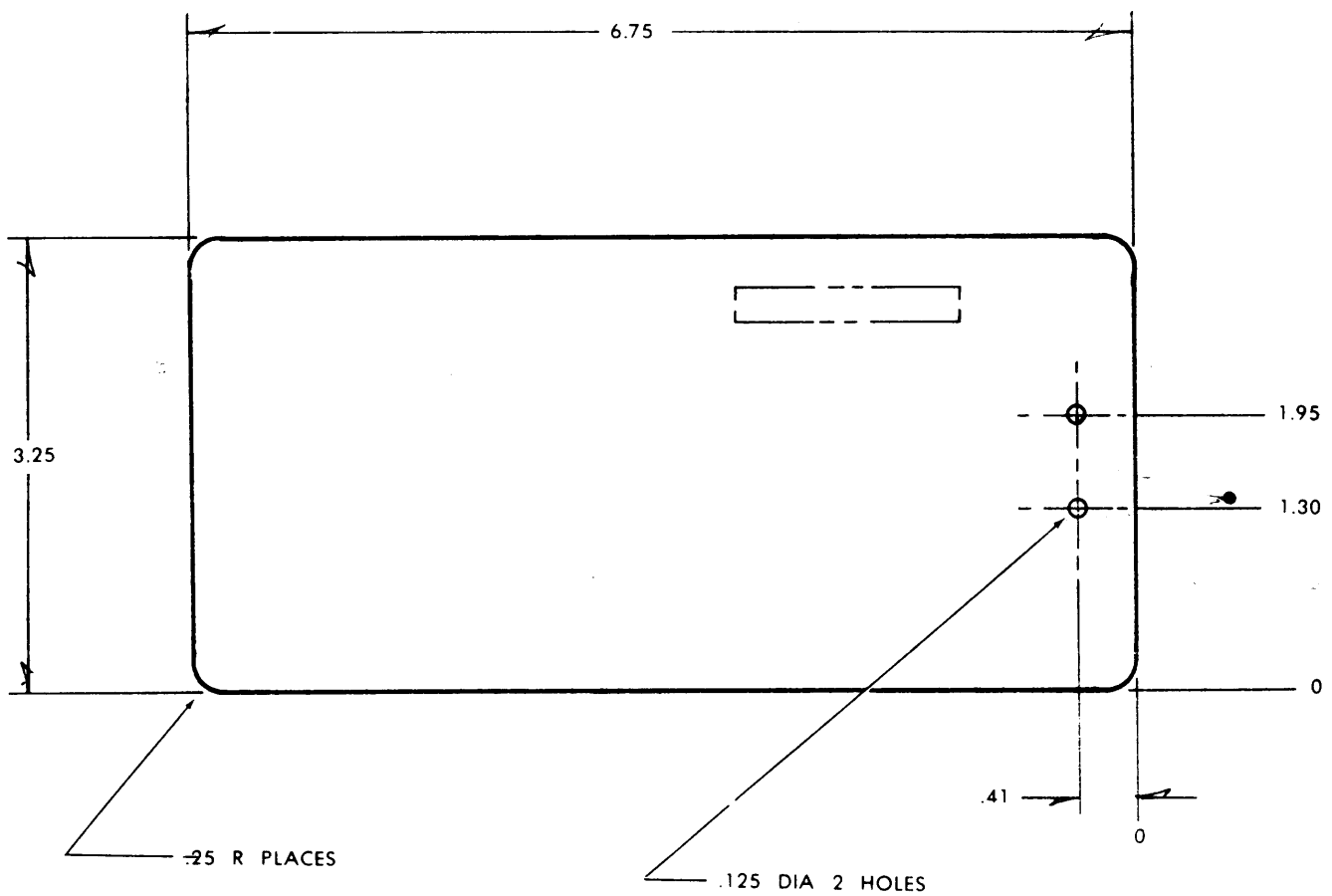
**Figure D-259.** Part Number 204-075 -230-5 BUS BAR  
 Fabricate from: NSN 6150-00-225-0267  
 Material: Copper Sheet, Federal Specification QQ-C-576, Annealed, 0.063 Inch Thick, 2.7 Inches Wide, 4.1 Inches Long



NOTE:

MAKE FROM MS91587-4 SHUNT

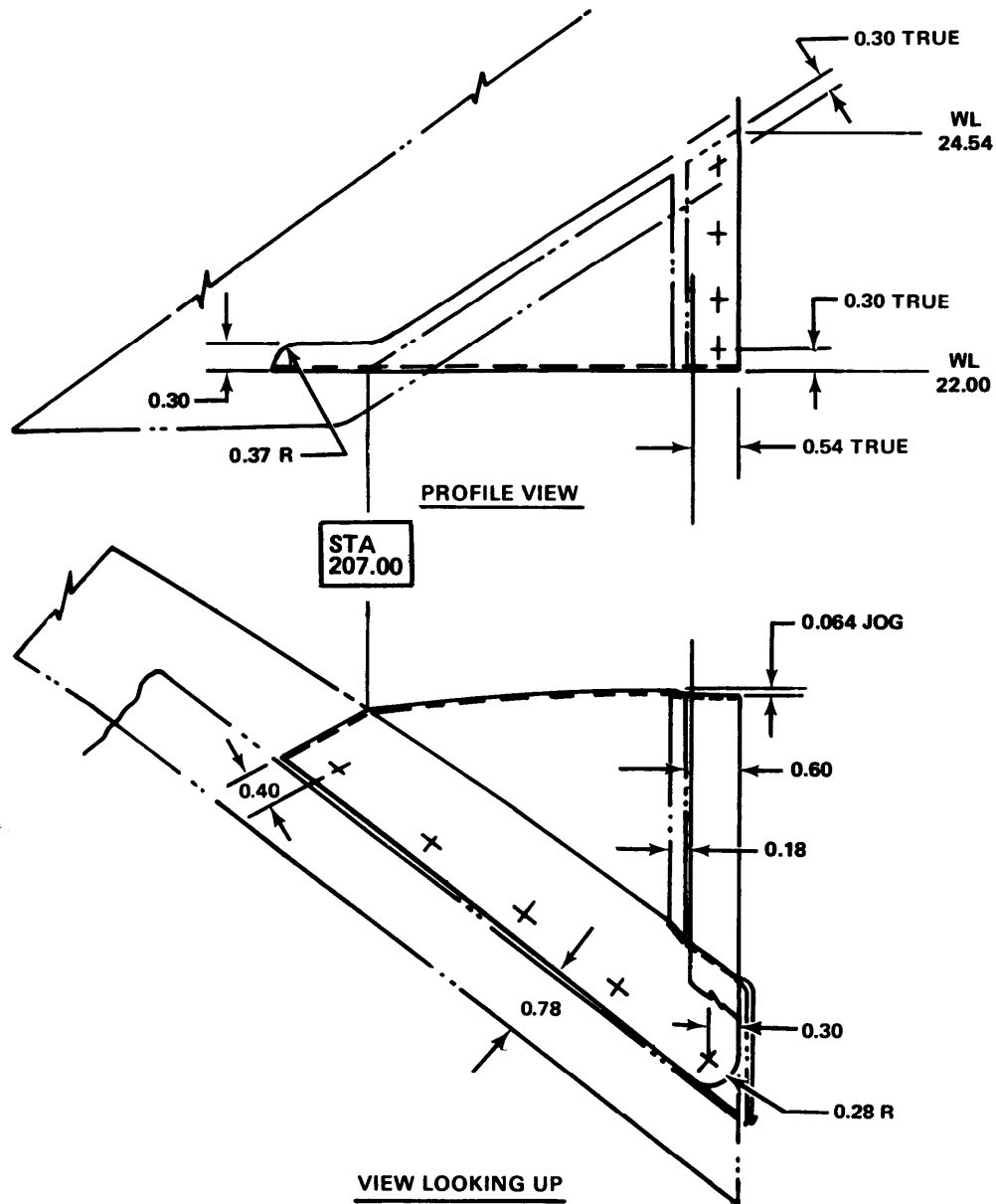
**Figure D-260.** Part Number 204-075-152-3 SHUNT Assembly  
Fabricate from: NSN 6625-00-166-1005, MS91587-4 SHUNT  
Material: MS91587-4 SHUNT, By Installing Above Bolts in Place of Furnished Bolts



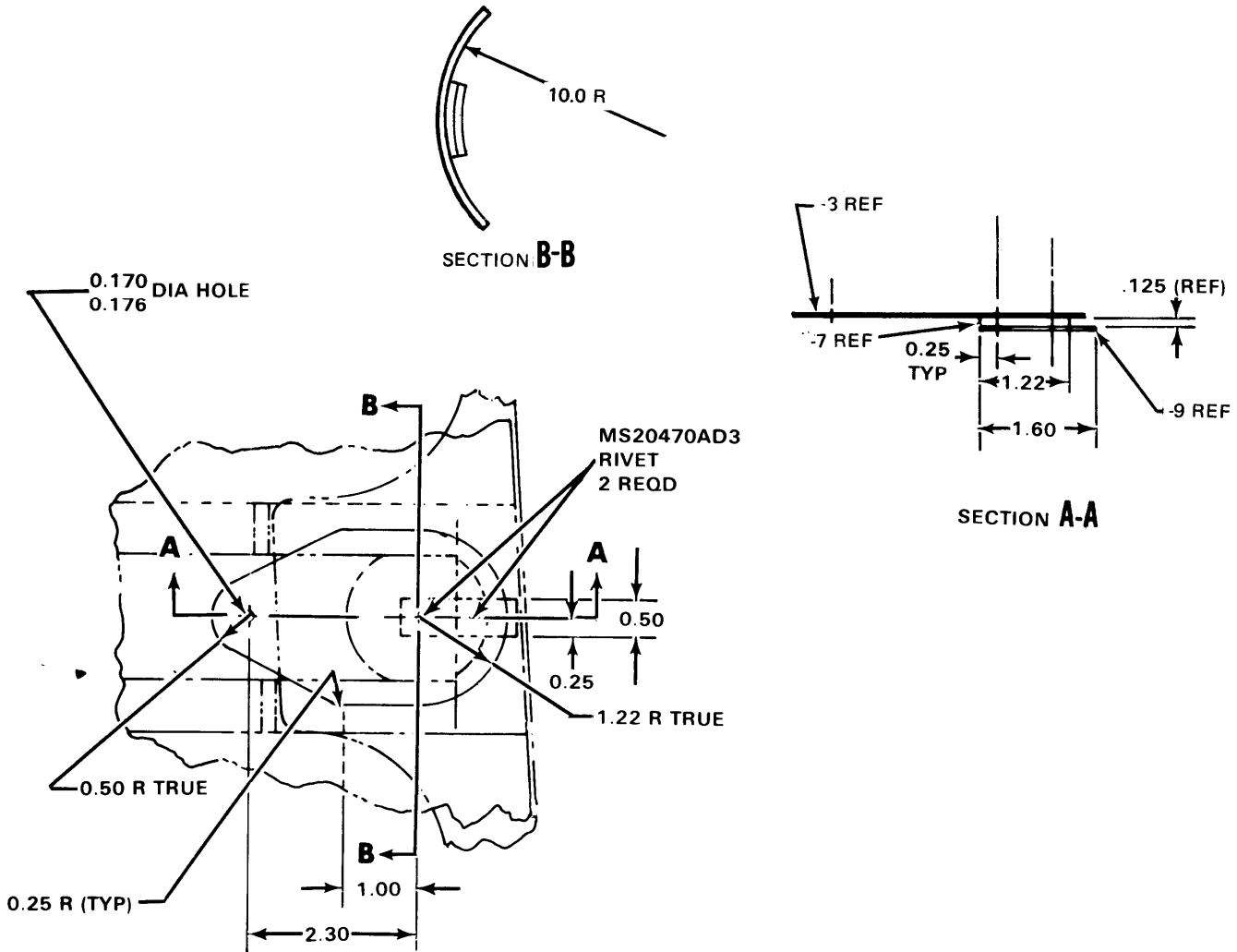
**Figure D-261.**

Fabricate from:  
Material:

Plate, Doubler, Rear PN 5065697  
NSN 9535-00-232-1882  
AL Alloy, 6061-T6, .062 THK, QQ-Q-250/11



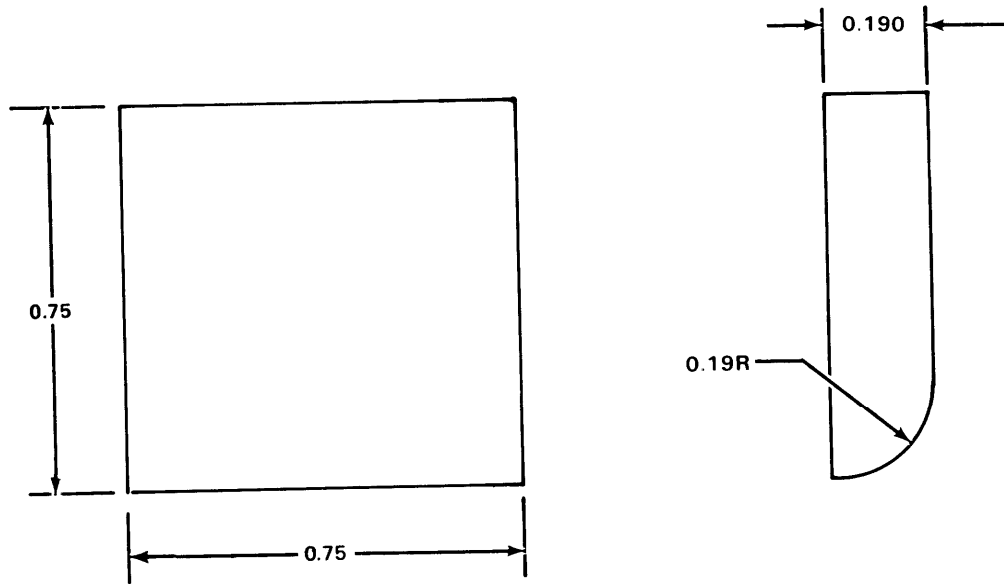
**Figure D-262.** Part Number 206-030-137-4 GUSSET  
 Fabricate from: NSN 9635-00-232-0489  
 Material: 2024 AL ALY Federal Specification QQ-A-362,  
 Temp 0 T42, to 0.032 Inch Thick, 5.5 Inches Wale,  
 6.0 Inches Long



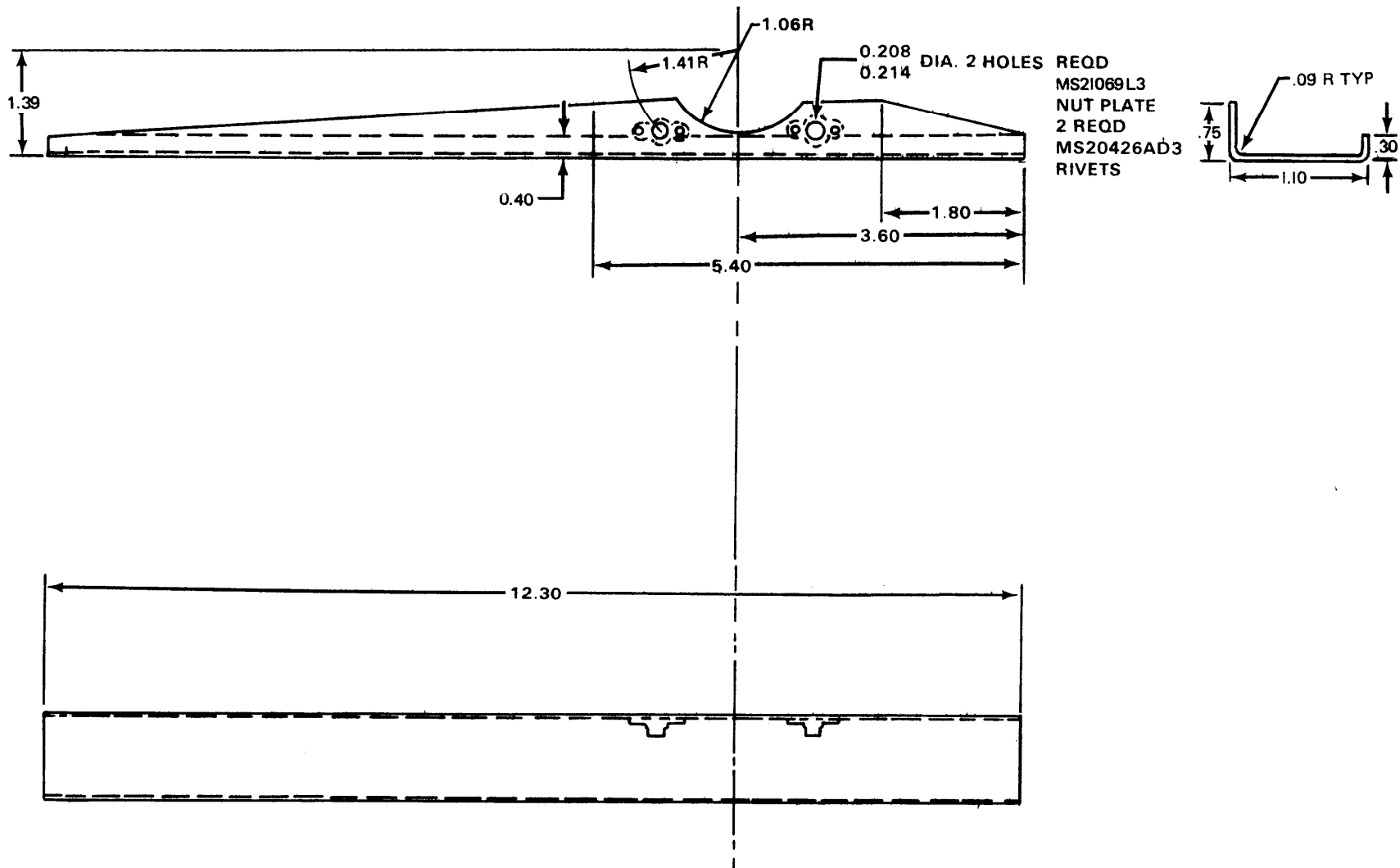
**NOTES:**

1. 205-030-148-5 COVER MAKE FROM .2024 AL ALY FEDERAL SPECIFICATION QQ-A-250/5 T3 0.040 INCH THICK, 5.0 INCHES LONG, 5.0 INCHES WIDE
2. 205-030-148-7 SPACER MAKE FROM 2024 AL ALY FEDERAL SPECIFICATION QQ-A-250/5 T3 0.125 INCH THICK, 1.0 INCH WIDE, 1.72 INCHES LONG
3. 205-030-148-9 PLATE MAKE FROM 2024 AL ALY FEDERAL SPECIFICATION QQ-A-250/5 T3 0.040 INCH THICK, 1.0 INCH WIDE, 2.1 INCH LONG

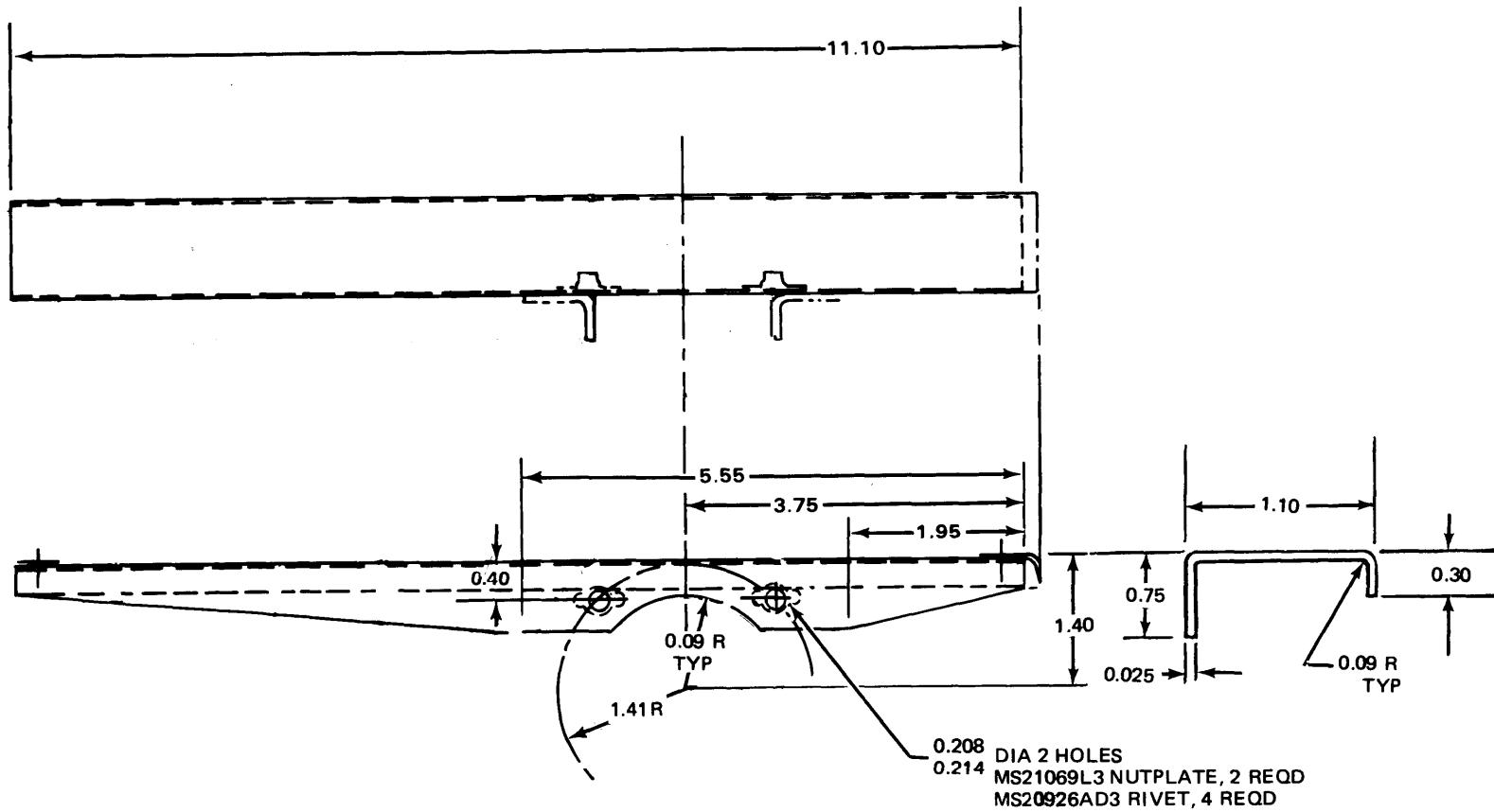
**Figure D-263.** Part Number 205-030-148-3 COVER Assy of  
 Fabricate from, NSN 9535-00-167-2280  
 NSN 9535-00-232-0418  
 Material: 2024 AL ALY Federal Specification QQ-A-250/5 T3 0.040 Inch Thick  
 2024 AL ALY Federal Specification QQ-A-250/5 T3 0.125 Inch Thick



**Figure D-264.** Part Number 205-030-164-215 RADIAL BLOCK  
Fabricate from: NSN 9535-00-086-4516  
Material: 7075 AL ALY Federal Specification QQ-A-250/3 T6 0.190  
Inch Thick, 0.8 Inch Wide, 0.8 Inch Long

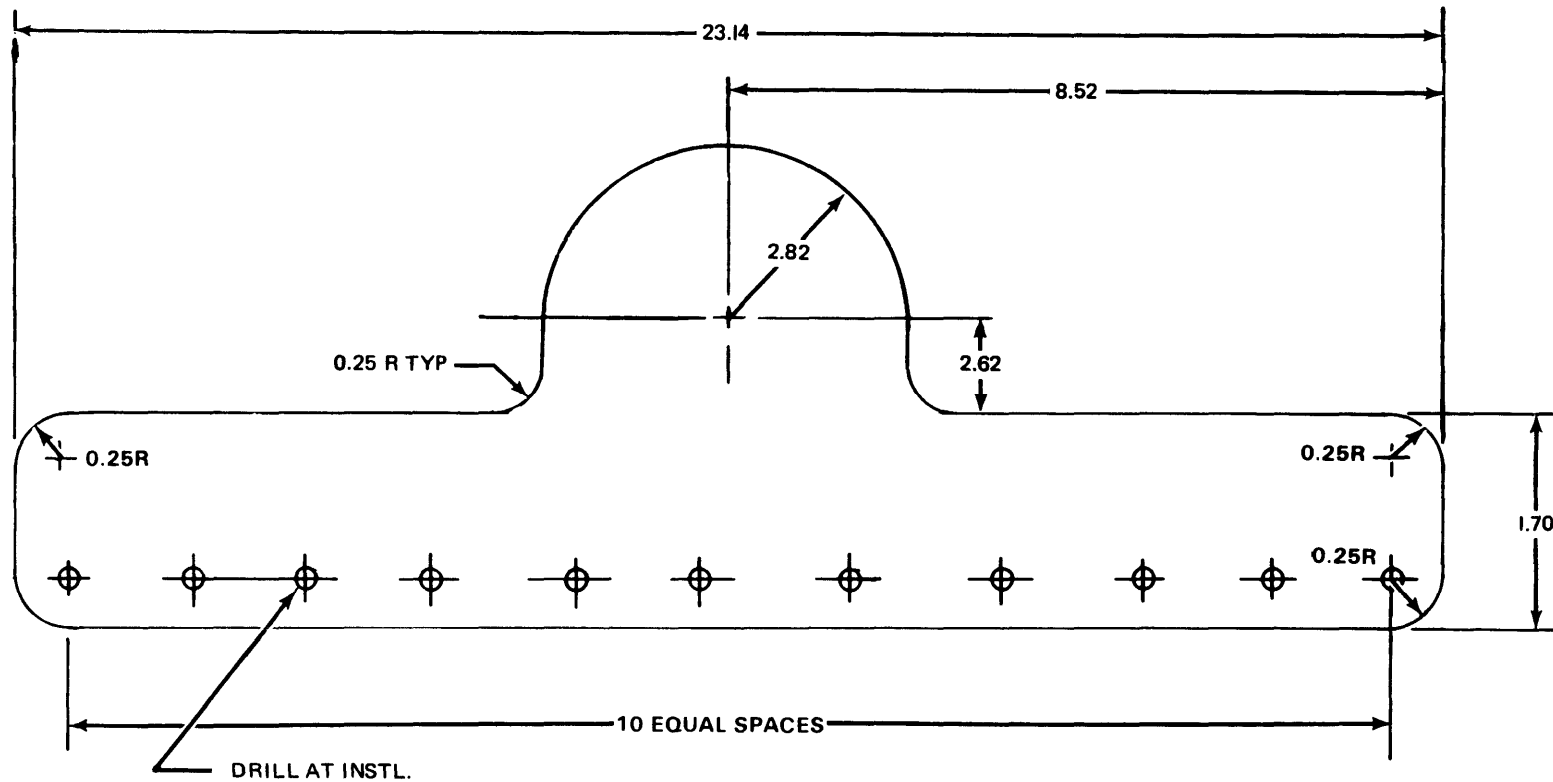


**Figure D-265.** Part Number 205-030-239-3 BEAM  
 Fabricate from: NSN 9635-00-232-0646  
 Material: 2024 AL ALY Federal Specification QQ-A-362, T3,  
 0.020 Inch Thick, 3.6 Inch Wide, 12.8 Inch Long

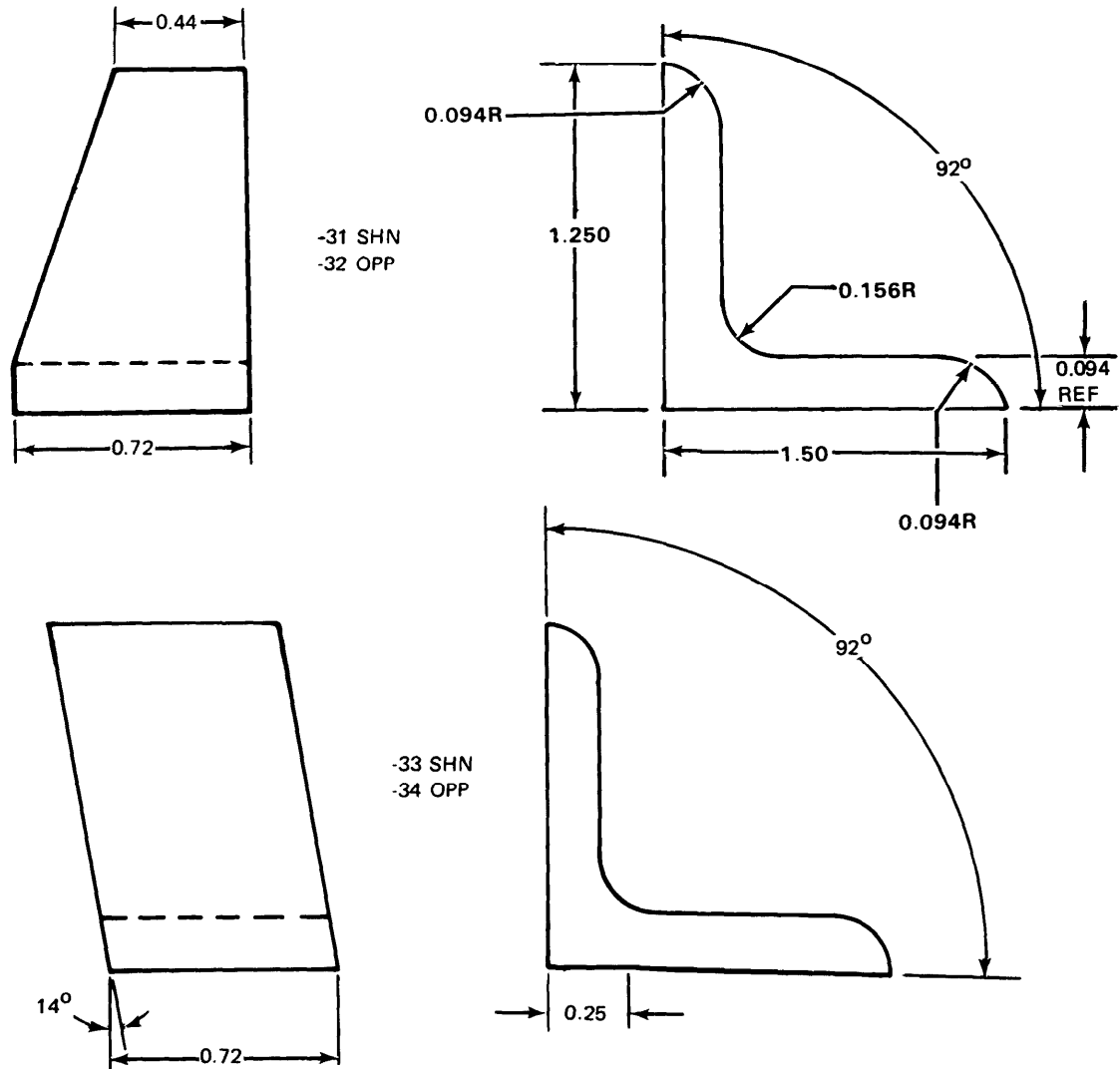


**Figure D-266.** Part Number 206-030-239-5 BEAM  
 fabricate from: NSN 9535-00-232-0546  
 Material: 2024 AL ALY, Federal Specification QQ-A-250/5, T-3  
 0.020 Inch Thick, 3.6 Inch Wide, 11.06 Inch Long





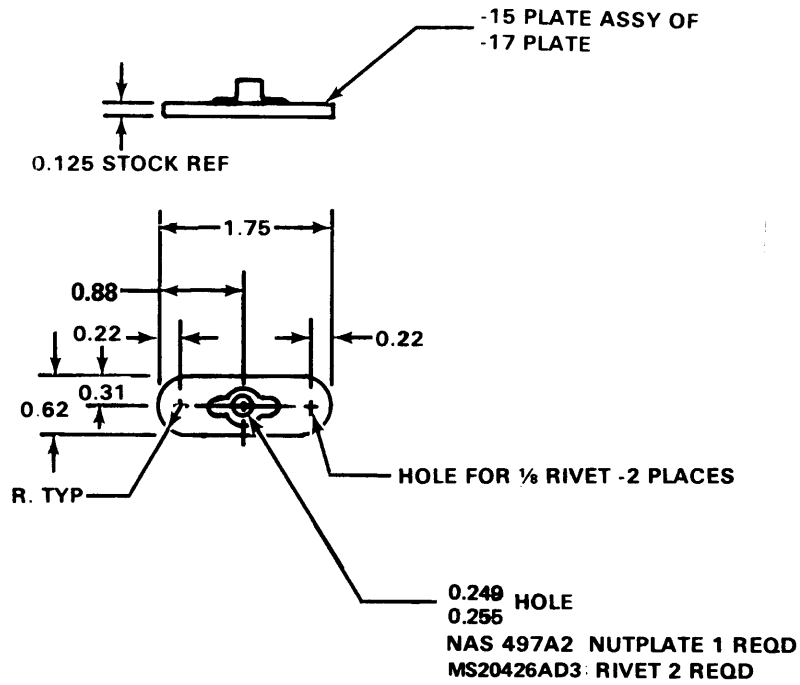
**Figure D-267.** Part Number 205-030-257-15 DOUBLER  
Fabricate from: NSN 9535-00-086-9860  
Material: 7075 AL ALY Sheet Federal Specification QQ-A-250/13 T-6  
0.032 Inch Thick, 5.8 Inch Wide, 23.3 Inch Long



**NOTES:**

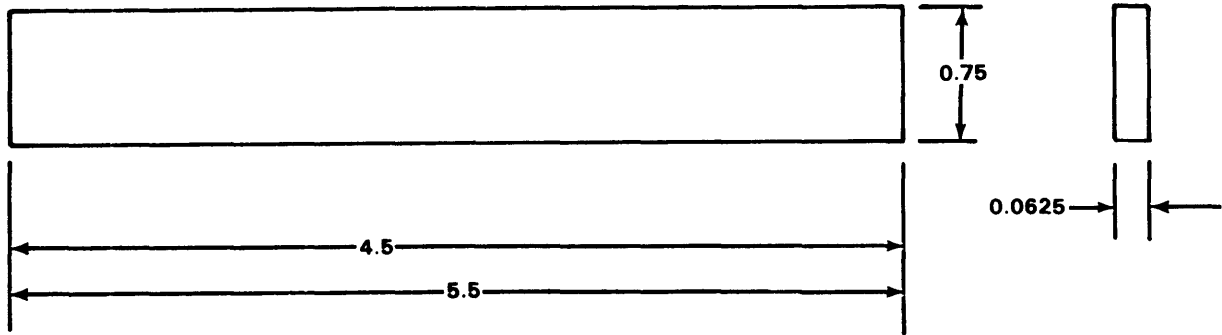
1. 206-031-423-31 & -32 CLIP  
MAKE FROM AND 10134-1406 STRUCTURAL  
ANGLE ALUMINUM EXTRUSION 1.1 INCHES LONG
2. 205-031-423-33 & -34 CLIP  
MAKE FROM AND 10134-1406 STRUCTURAL  
ANGLE ALUMINUM EXTRUSION 1.5 INCHES LONG
3. DRILL HOLES TO MATCH TO INSTALL

<b>Figure D-268.</b>	Part Number	206-031-423-31 CLIP 206-031-423-32 CLIP 206-031-423-33 CLIP 206-031-423-34 CLIP
	Fabricate from:	NSN 9640-00-596-3006
	Material:	7076 Structural Angle Alum ALY Extruded 90 Deg. Federal Specification QQ-A-200-11 T6, 1.250 Inch H of 1 Leg. 1.60 Inch H of Other Leg, 0.094 Inch Thick



- NOTES:
1. 205-031-481-17 PLATE MAKE FROM METAL STRIP STEEL 0.125 INCH THICK
  2. RIVET NUTPLATE TO 205-031-481-17 PLATE

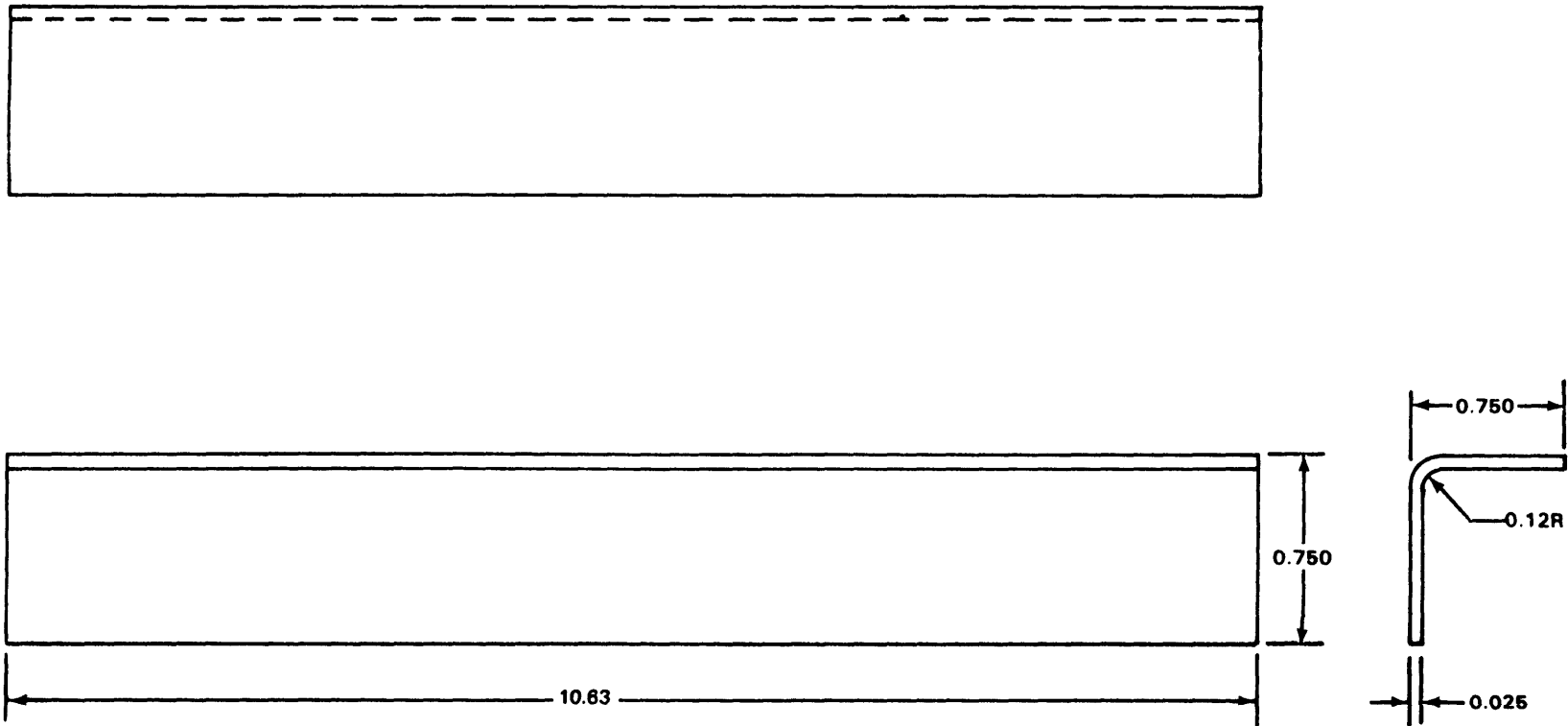
**Figure D-269.** 206-031-481-15 PLATE, Assy of  
 NSN 9515-00-204-0220  
 Metal Strip, Steel Annealed  
 Federal Specification MIL-S-18729 Comp 4130, Cond N  
 0.125 Inch Thick, 1.2 Inch Wide, 2.3 Inch Long



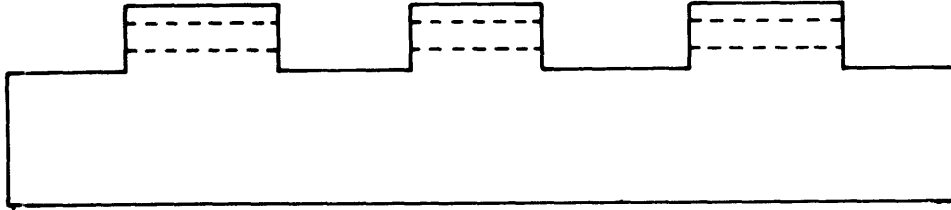
**NOTES:**

1. 205-031-481-23 BUMPER MAKE FROM 0.0625 INCH THICK SYNTHETIC RUBBER 5.5 INCHES LONG
2. 205-031-481-29 BUMPER MAKE FROM 0.0625 INCH THICK SYNTHETIC RUBBER 4.5 INCHES LONG

Figure D-270.	Part Number	205-031-481-23 BUMPER 205-031-481-29 BUMPER
	Fabricate from: Material;	NSN 9320-00-202-1846 Rubber Sheet Synthetic Federal Specification MIL-R-8855, Class 3, Grade 60, 0.0625 Inch Thick, 0.75 Inch Wide



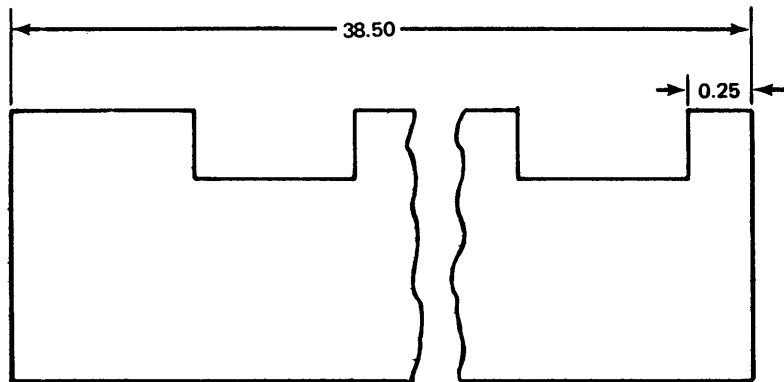
**Figure D-271. Part Number 205-031-668-65 ANGLE**  
**Fabricate from: 9535-00-167-2278**  
**Material: 2024 AL ALY, Federal Specification QQ-A-250/5 T3**  
**0.032 Inch Thick, 1.9 Inch Wide, 11.2 Inch Long**



**NOTES:**

1. 205-031-862-17S HINGE HALF  
MAKE FROM MS20257HP2-7200 LEAF  
BUTT HINGE MATERIAL
2. 205-031-862-21S HINGE HALF  
MAKE FROM MS20257HP2-7200 LEAF  
BUTT HINGE MATERIAL
3. CUT HINGE MATERIAL TO PROPER  
LENGTH
4. DESIGNATION IS SYNTHETIC PART NO.

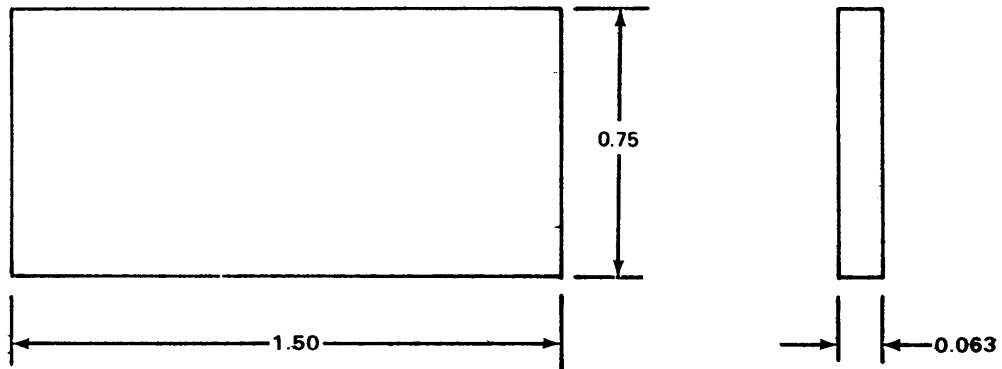
Figure D-272.	Part Number	205-031-862-17S HINGE HALF 205-03-862-21S
	Fabricate from:	NSN 5340-00-993-1461
	Material:	Leaf Butt Hinge AL ALY Anodized, 0.040 Inch Thick, 0.531 Inch Wide, 72.00 Inches Long



**NOTES:**

- 1, 205-031-862-19 HINGE HALF  
MAKE FROM MS20257YP2-385Q  
BUTT HINGE MATERIAL
2. CUT HINGE MATERIAL TO PROPER  
LENGTH 38.60 INCH LONG

**Figure D-273.** Part Number 205-031-862-19 HINGE HALF  
Fabricate from: NSN 5340-00-993-1461  
Material: Hinge, Butt, Alum Aly Anodized  
0.040 Inch Thick, 0.531 Inch Wide

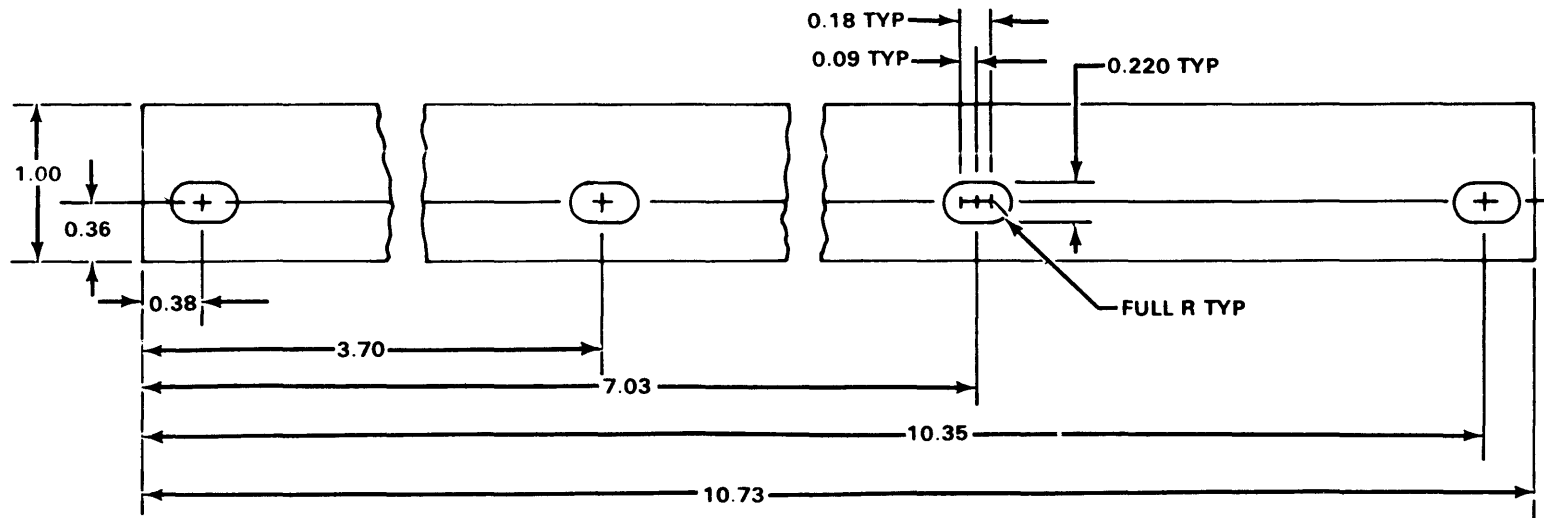


**NOTES:**

1. 205-031-862-47S STRIP MAKE FROM NYLATRON GS SHEET MATERIAL
2. PART SHALL BE FREE OF ALL SHARP EDGES AND SHARP CORNERS
3. PURCHASE MATERIAL FROM POLY MAR CORP, READING, PA. CODE IDENT NO. 83616

<b>Figure D-274.</b>	Part Number	205-031-862-47S STRIP
	Fabricate from:	No national stock number
	Material:	Plastic sheet, 0.063 Inch Thick, 1.25 Inch Wide, 2.0 Inches Long

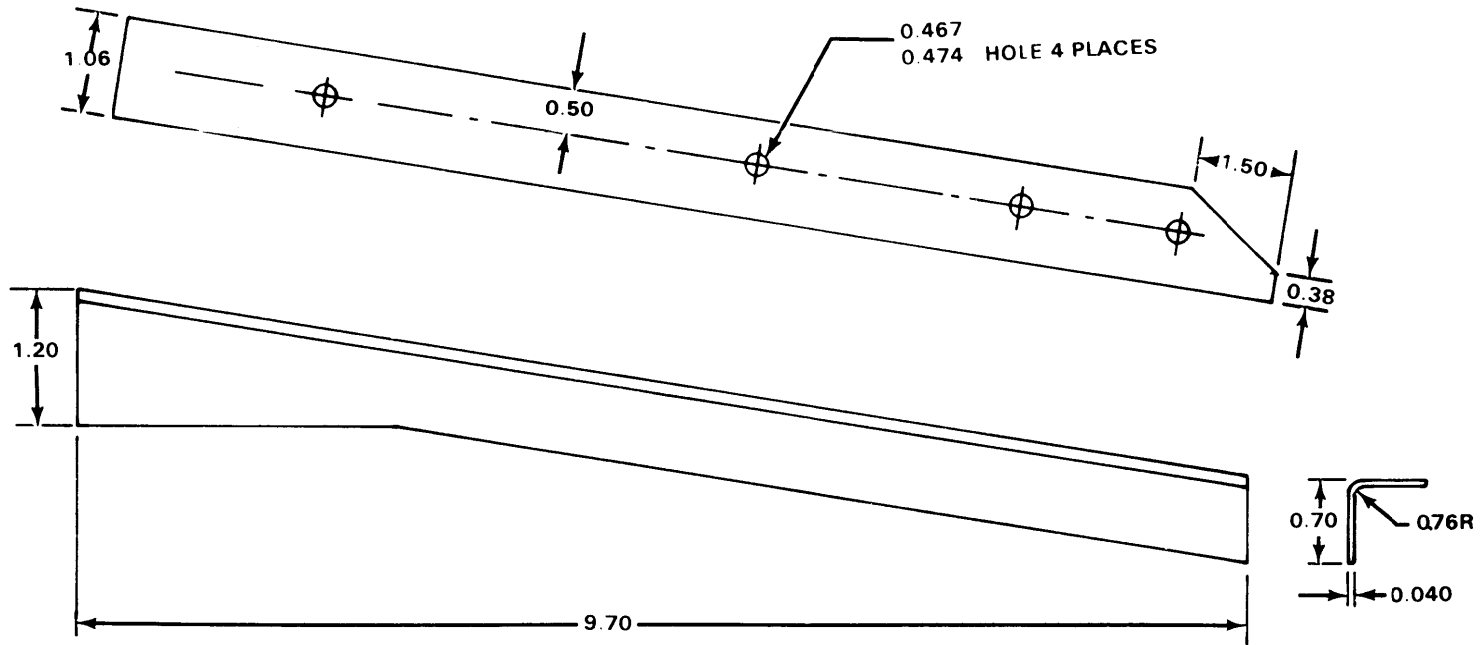




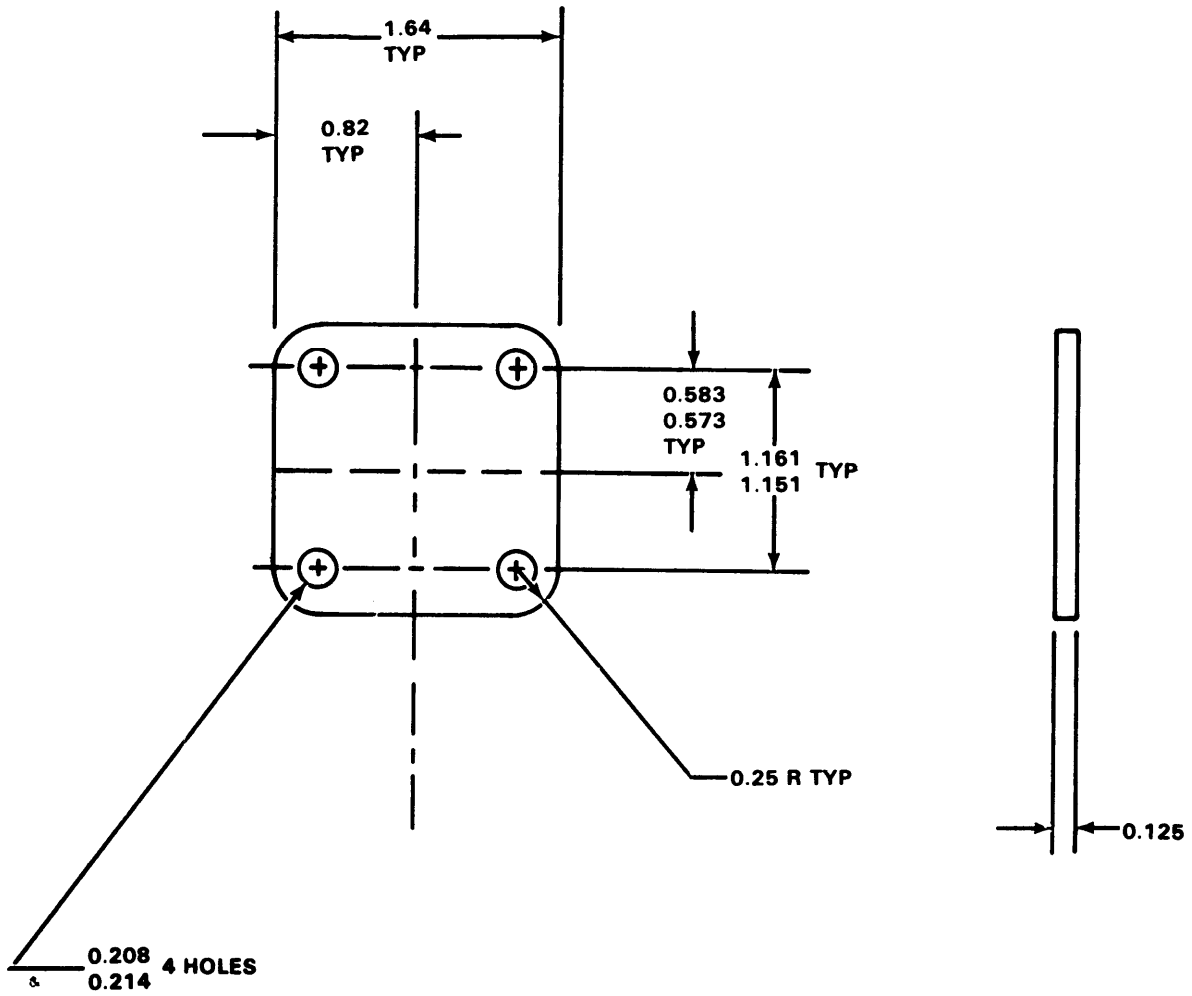
**NOTES:**

**205-060-110-1 FILLER MAKE FROM LAMINATED SHIM AMS 4013**

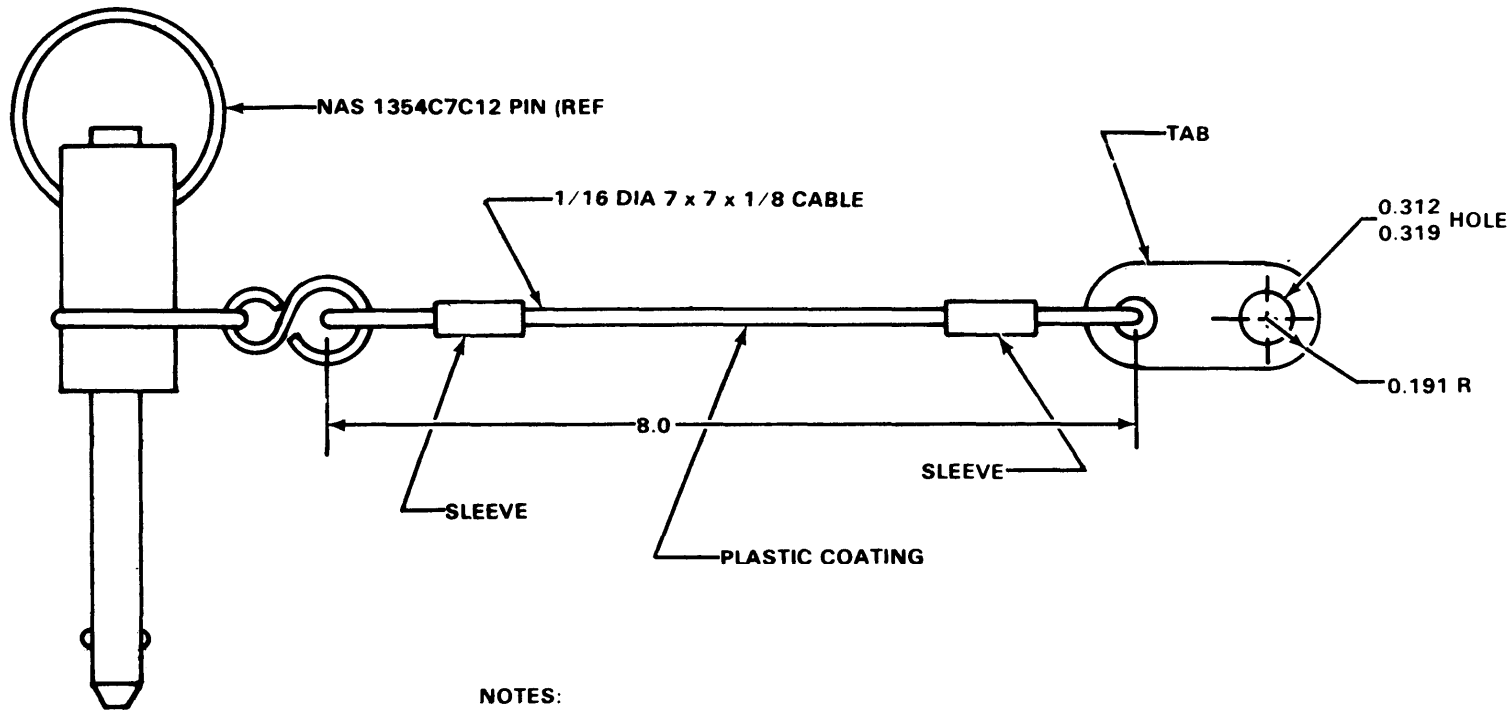
Figure D-275. Part Number 205-060-110-1 FILLER, Laminated  
 Fabricate From: NSN 9535-00-702-7786  
 Material : Shim Stock, Laminated Aluminum Federal Specification AMS 4013, 0.125 Inch Thick, 1.5 Inch Wide, 11.2 Inch Long



**Figure D-276. Part Number** 205-060-205-19 ANGLE Shown  
 205-060-205-20 ANGLE Opposite  
**Fabricate from:** NSN 9535-00-084-4551  
**Material:** 2024 AL ALY, Federal Specification QQ-A, 250/5  
 T3, 0.040 Inch Thick, 2.6 Inch Wide, 10.4 Inch Long



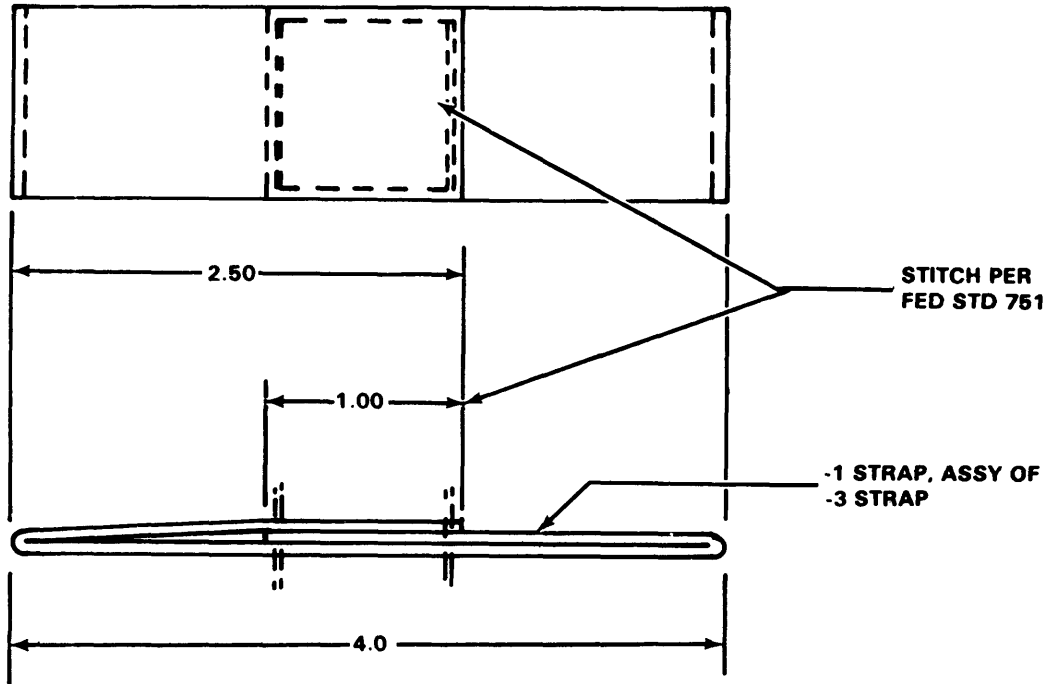
**Figure D-277.** Part Number 205-062-696-1 PLATE  
 Fabricate from: NSN 9635-00-232-0478  
 Material: 2024 AL ALY Federal Specification QQ-A-250/5 T3,  
 0.125 Inch Thick, 1.7 Inch Wide. 1.7 Inch Long



**NOTES:**

1. CABLE: CORROSION RESISTANT PER MIL-W-5424
2. COATING: PLASTIC PER MIL-I-631, TYPE F, GRADE A CLASS II, CAT. I
3. SLEEVE: COPPER, ZINC PLATED 2 REQD.
4. TAB: 2024 AL ALY, FEDERAL SPECIFICATION QQ-A-250 T4, 0.040, NSN 9535-00-086-9930, ANODIZED PER MIL-A-8625, TYPE 1
5. LANYARD MAY BE MADE FROM LW-1023-1-8 PURCHASED FROM HARTWELL CORP, LOS ANGELES, CALIF CODE IDENT NO. 83014

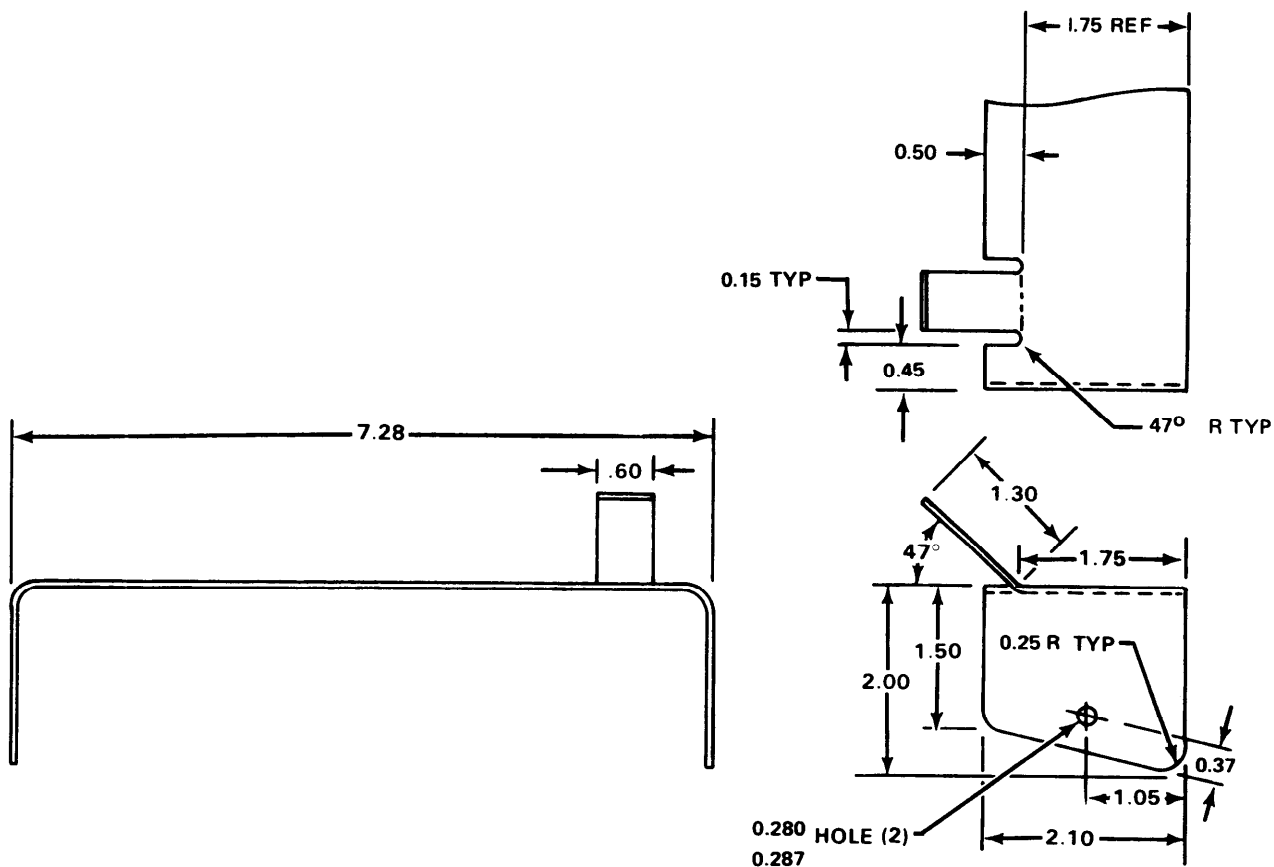
**Figure D-278.** Part Number 206-072-221-3 LANYARD  
 Fabricate from: NSN 4010-00-075-7941  
 Material:



**NOTES:**

1. 205-070-772-3 STRAP MAKE FROM TYPE XVII X 10.5 NYLON WEBBING MIL-W-4088-COLOR LIGHT GULL GREY NO. 36440 FED STD 595
2. NYLON THREAD MIL-T-7808
3. HEAT SEAR ENDS OF ALL WEBBING

**Figure D-279.** Part Number 205-070-772-1 STRAP, Assembly  
Fabricate from: NSN 8305-00-267-3009  
Material: Nylon Webbing Type XVII, MIL-W-4088



- NOTES:**  
 1. MARK PER BPS FW 4050  
 2. ALL INSIDE RADII 0.25

Figure D-280. Part Number 205-070-795-1 COVER  
 Fabricate from: NSN 9535-00-232-0378  
 Material: 2024 AL ALY, Federal Specification QQ-A-362 T3,  
 0.063 Inch Thick, 3.5 Inch Wide, 11.70 Inch Long

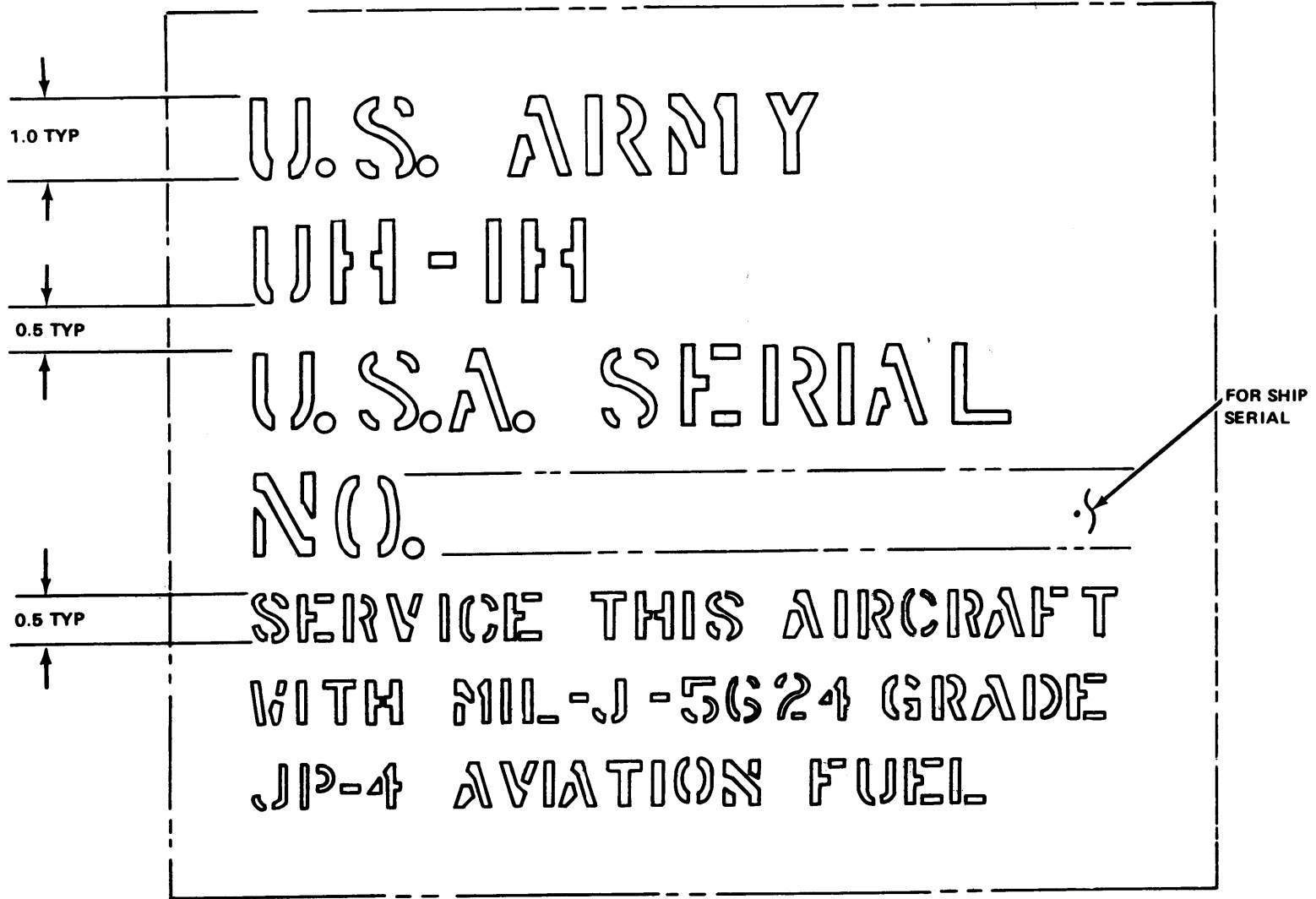
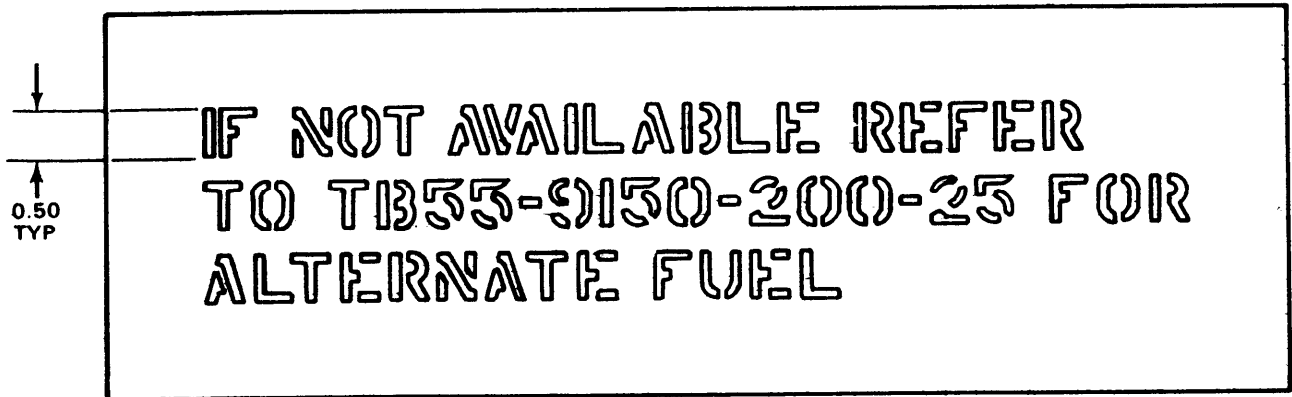


Figure D-281.

NOTES:

LETTERS TO BE SPACED APPROX AS SHOWN

<b>Figure D-281.</b>	<b>Part Number</b>	<b>205-070-862-1 STENCIL</b>
	<b>Fabricate from:</b>	<b>9310-00-265-6797</b>
	<b>Material:</b>	<b>Stencil Board, Federal Specification UU-S-625</b>
		<b>Type 2, Grade 1</b>

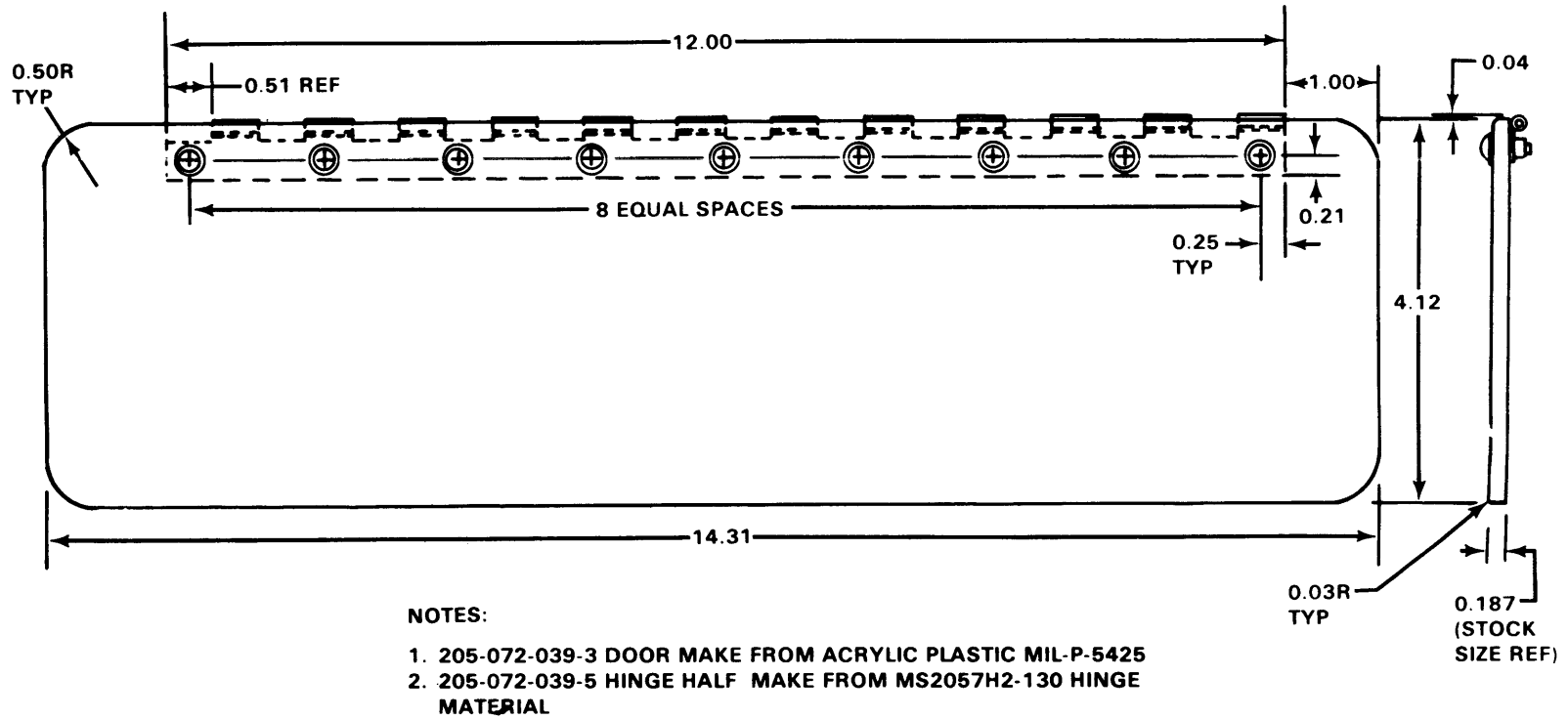


**NOTES:**

**LETTER TO BE SPACED AS SHOWN**

**Figure D-282.** Part Number 205-070-882-1 STENCIL  
Fabricate from: NSN 9310-00-265-6797  
Material: Stencil Board, Federal Specification UU-S-625,  
Type 2 Grade 1





**Figure D-283.** Part Number 205-072-039-1 DOOR, Assy Of  
 Fabricate from: NSN 9330-00-291-4800,  
 NSN 5340-00-993-1461  
 Material: Plastic sheet Acrylic Transparent, Federal Specification  
 MIL-P-5425 FINA, 0.187 Inch Thick, 4.2 Inch Wide, 14.4 Inch Long  
 Leaf, Butt Hinge A1 A AL ALY 0.0531 Inch Wide Make From  
 MS20257HP2-130 (Length 13.0)

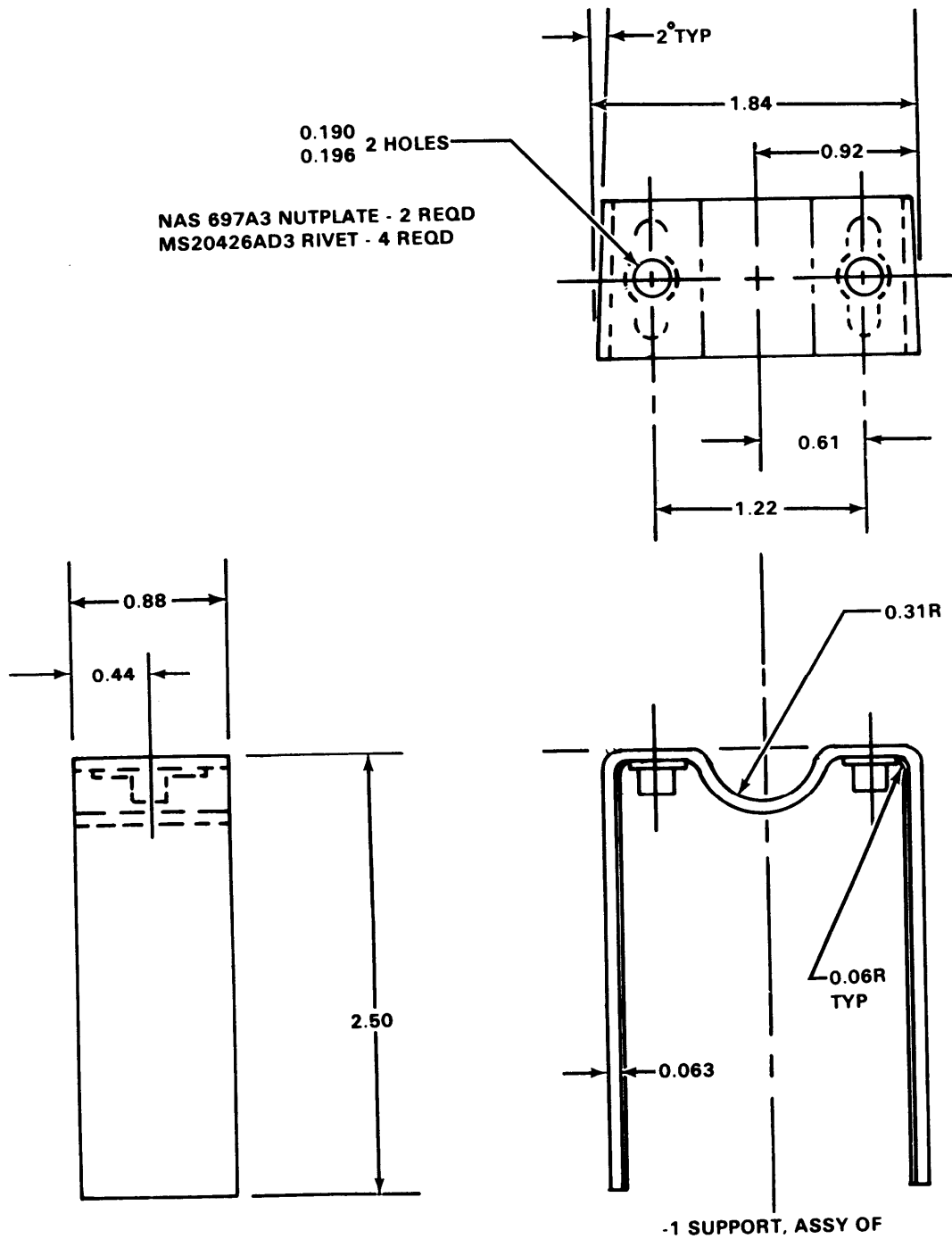
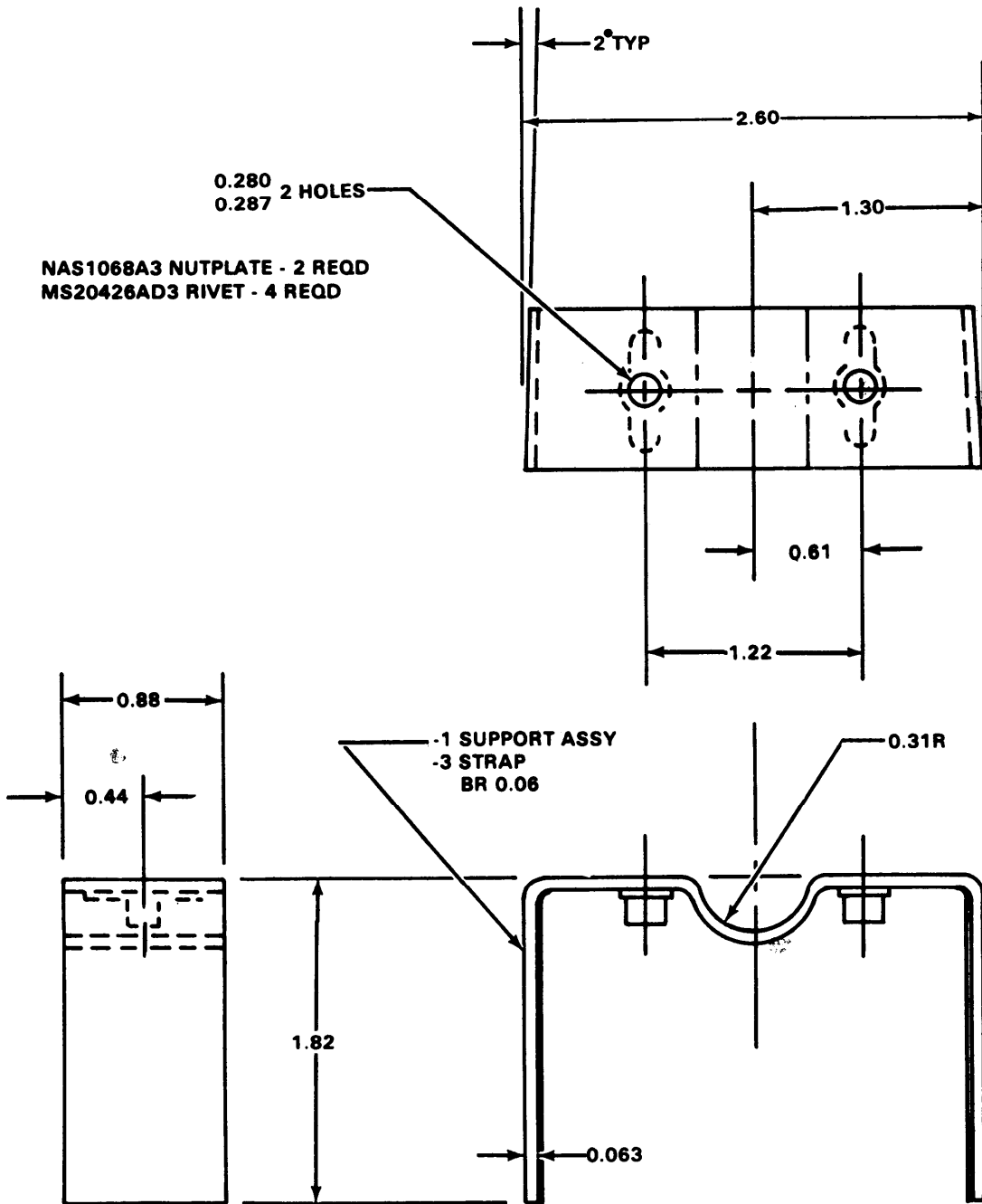


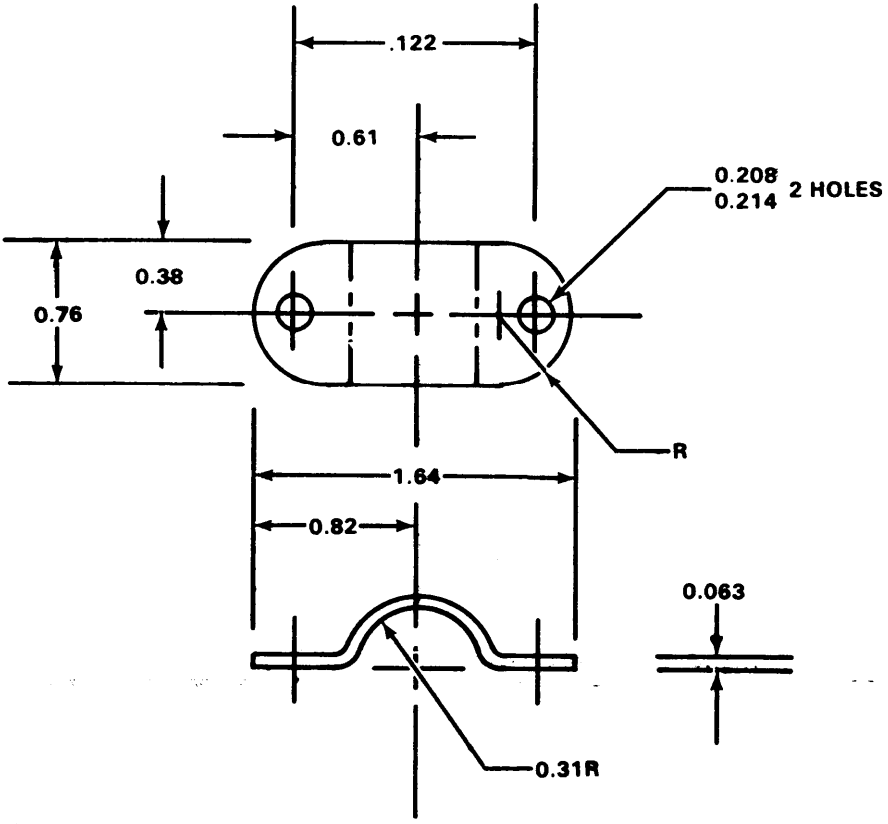
Figure D-284.

Part Number  
Fabricate from:  
Material:

206-072-224-1 GUIDE TUBE  
NSN 9535-00-232-1882, 5310-00-728-7716  
6061 AL ALY Federal Specification QQ-A-205/11 TO,  
0.063 Inch Thick, 1.3 Inch Wide, 7.5 Inch Long

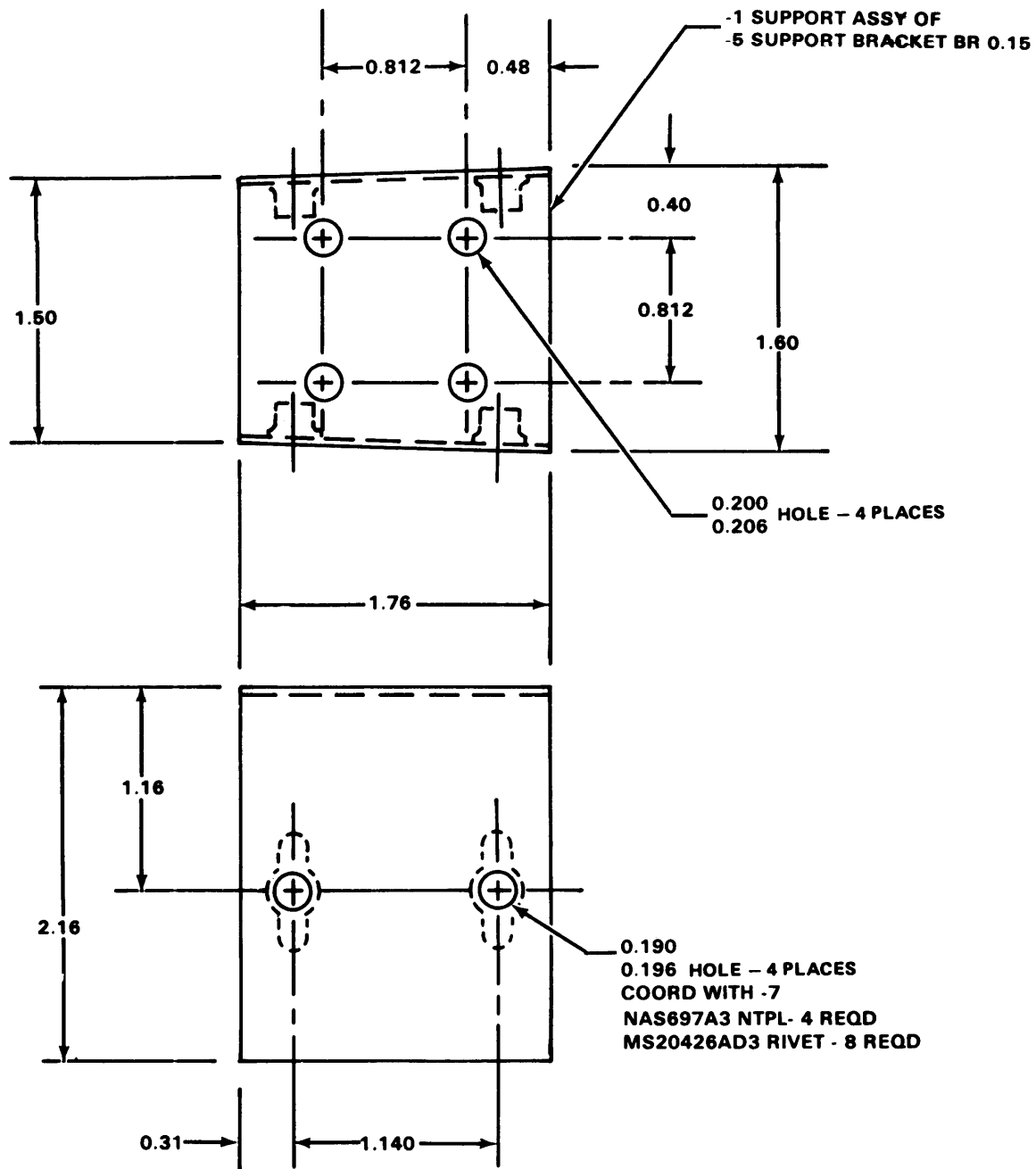


**Figure D-285.** Part Number 205-072-225-1 GUIDE-TUBE  
 Fabricate from: NSN 9635-00-232-1882, 5310-00-772-3720  
 Material: 6061 AL ALY, Federal Specification QQ-A-205/11, TO  
 0.063 Inch Thick, 1.3 Inch Wide, 6.7 Inch Long

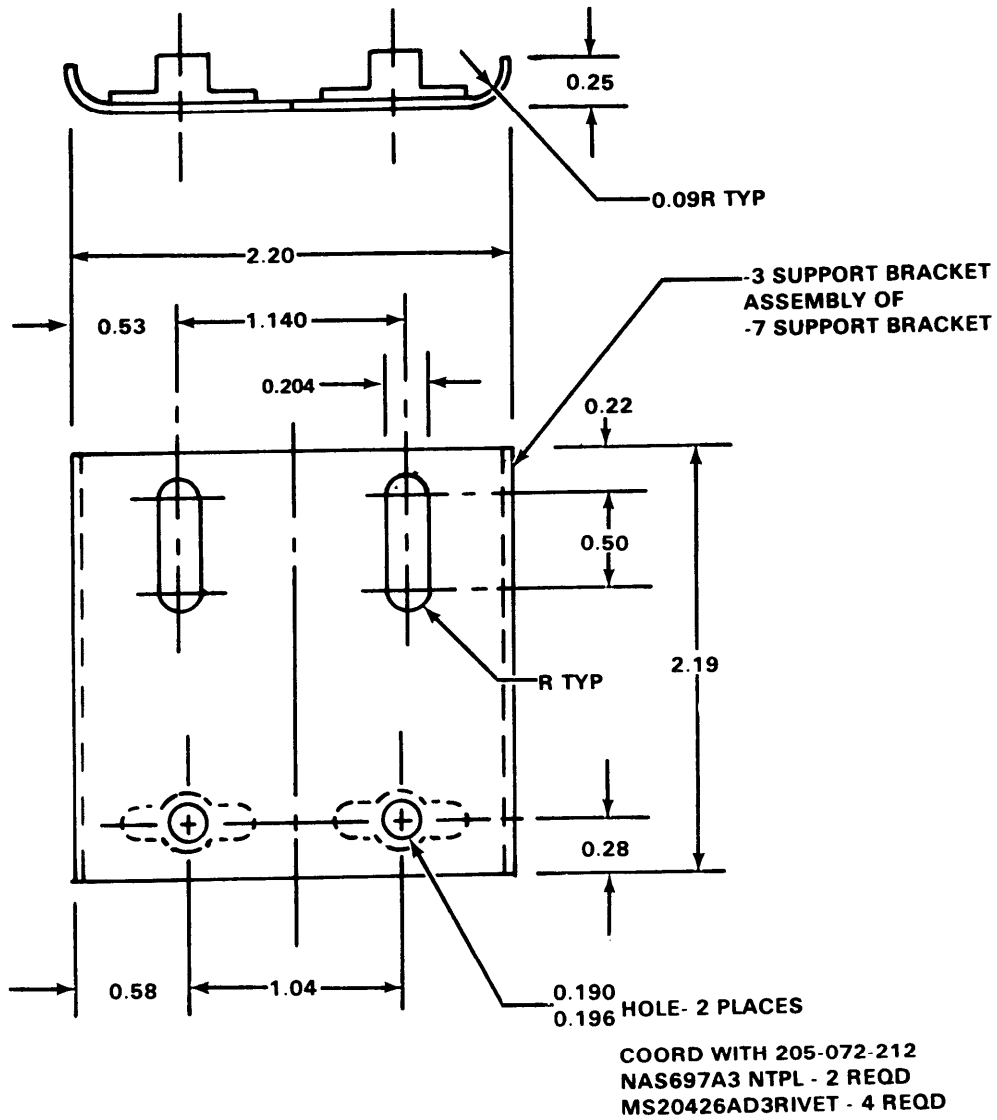


**NOTES:**  
**BEND RADIAS 0.06**

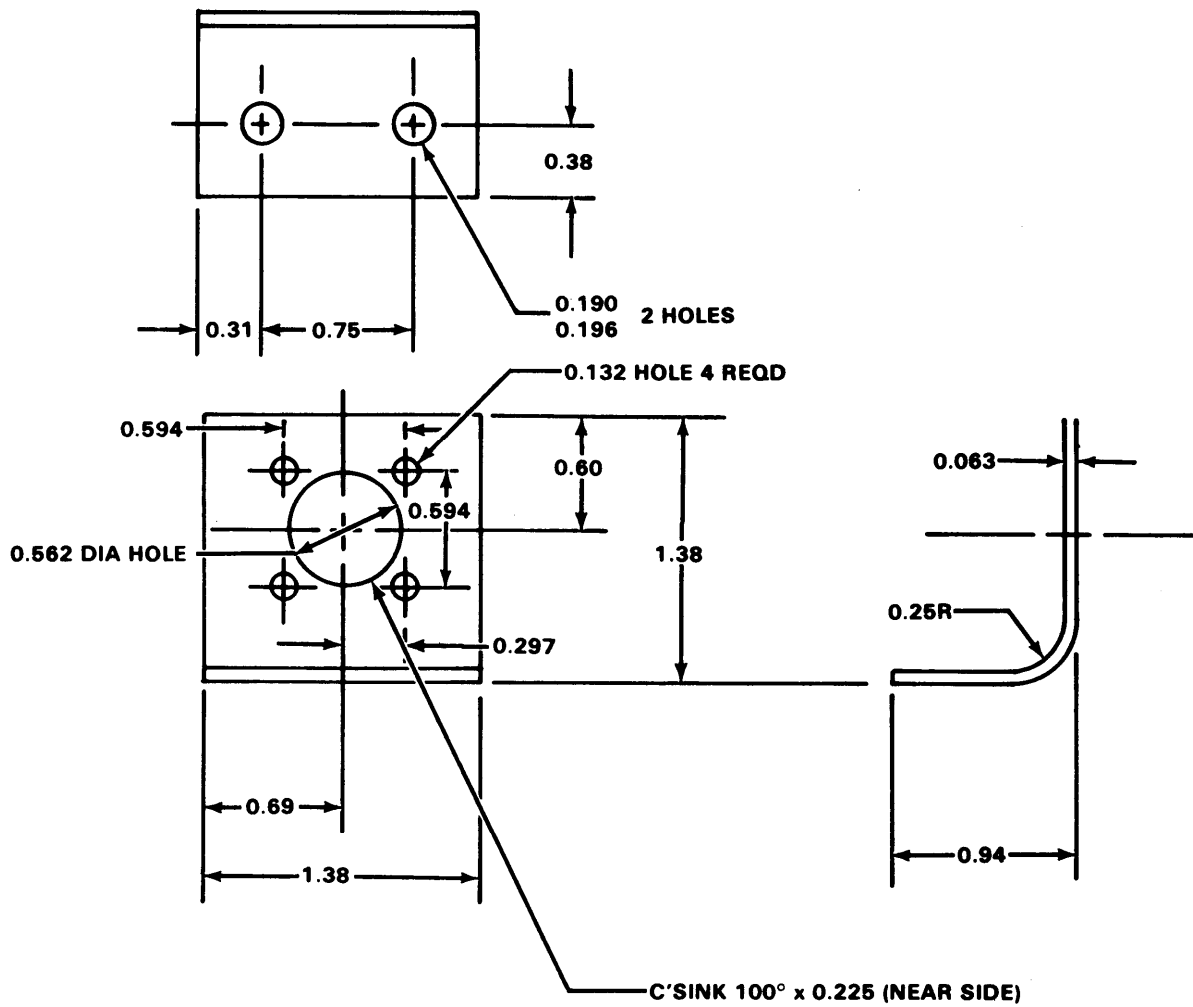
**Figure D-286.** Part Number 205-072-226-1 CLAMP-GUIDE  
Fabricate from: NSN 9535-00-232-1882  
Material: 6061 AL ALY Federal Specification QQ-A-250/11 TO,  
0.063 Inch Thick 1.0 Inch Wide, 3.0 Inch Long



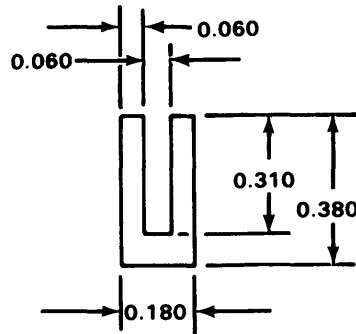
**Figure D-287.** Part Number 206-072-227-1 SUPPORT BRACKET ASSEMBLY OF  
Fabricate from: NSN 9635-00-167-2267, 5310-00-728-7716  
Material: 2024 AL ALY, Federal Specification QQ-A-250/6 TO,  
0.040 Inch Thick, 2.0 Inch Wide, 7.0 Inch Long



**Figure D-288.** Part Number 205-072-227-3 SUPPORT BRACKET, Assembly of  
 Fabricate from: NSN 9635-00-167-2267, 5310-00-728-7716  
 Material: 2024 AL ALY, Federal Specification QQ-A-250/5, TO,  
 0.032 Inch Thick, 3.0 Inch Wide, 3.0 Inch Long



**Figure D-289.** Part Number: 205-072-317-1 BRACKET  
 Fabricate from: NSN 9535-00-232-0378  
 Material: 2024 AL ALY Federal Specification QQ-A-250/5 T3,  
 0.063 Inch Thick, 1.5 Inch Wide, 2.38 Inch Long

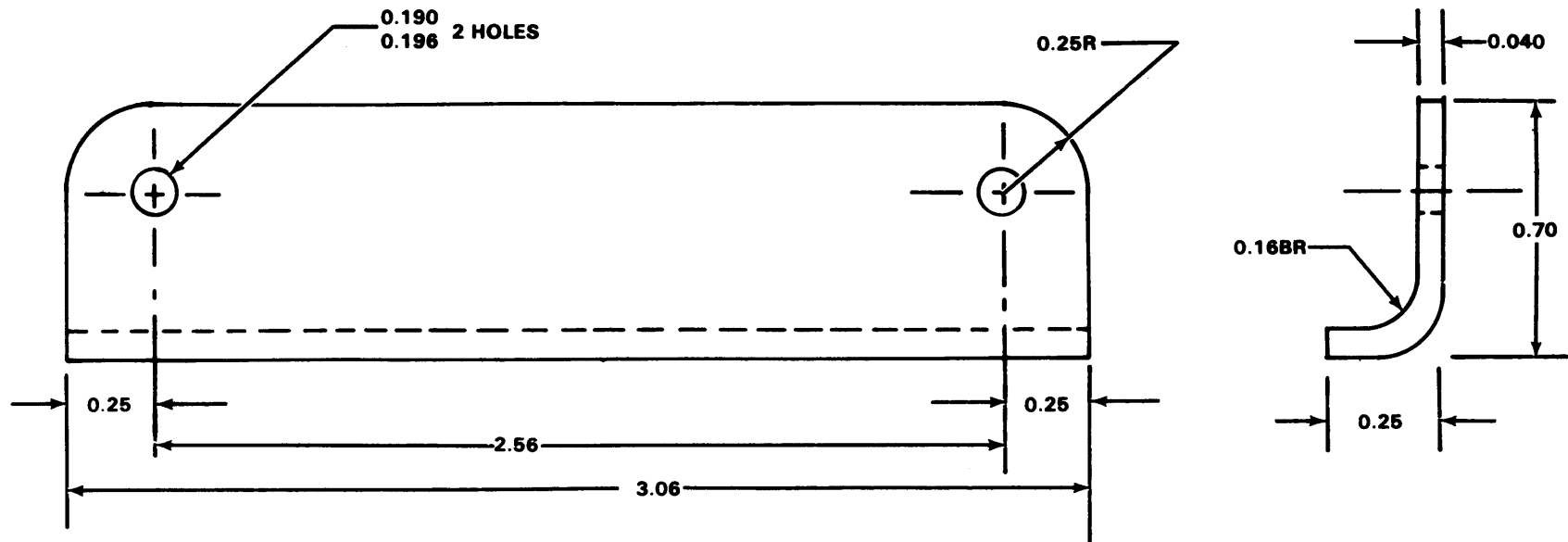


**NOTES:**

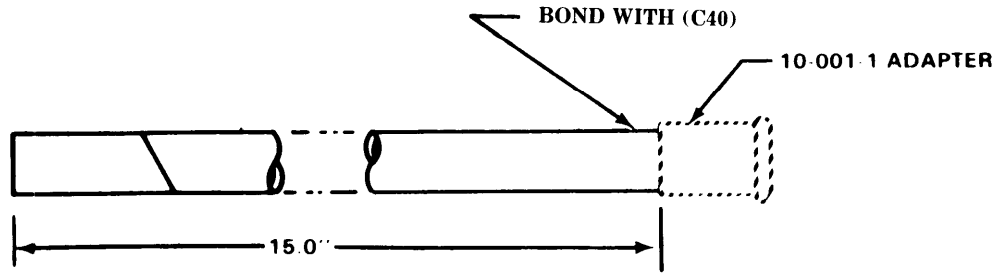
1. PART NO. 205-706-029-11 SEAL  
MAKE FROM BELL STD 110-076  
20 INCHES LONG
2. RUBBER EXTRUSION MAY BE PURCHASED  
FROM BELL HELICOPTER

<b>Figure D-290.</b>	Part Number	206-706-029-11 SEAL
	Fabricate from:	NSN 9390-00-134-0184
	Material:	Rubber Synthetic Extruded Federal Specification MIL-R-6855 Class II Grade 60, Color BLACK





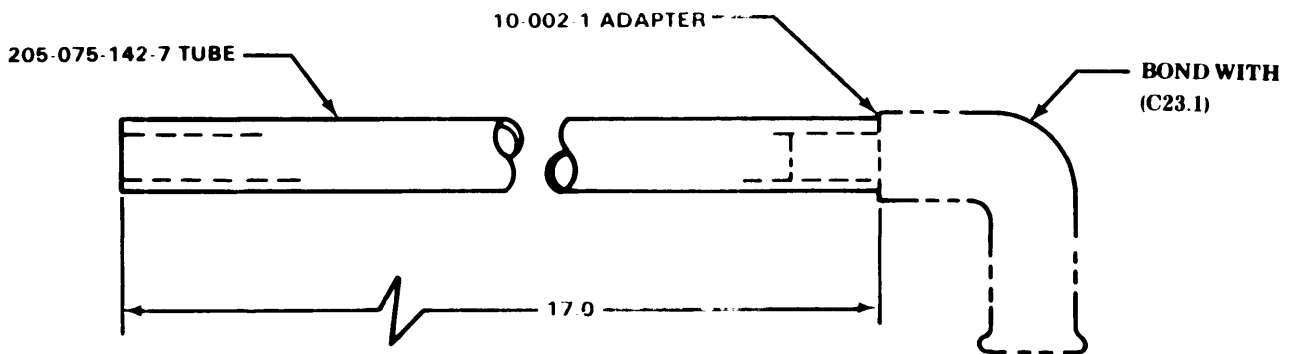
**Figure D-291.** Part Number: 205-706-029-15 LINK  
Fabricated from: NSN 9535-00-084-4551  
Material: 2024 AL ALY Federal Specification QQ-A-250/5 T-3  
0.040 Inch Thick, 1.0 Inch Wide, 5.0 Inch Long



**NOTES:**

1. PRIOR TO BONDS CLEAN SURFACES WITH ACETONE CHEM PURE OR METHYL ETHYL KETONE CHEM PURE
2. ALTERNATE MAT'L RUBBER-BLACK MIL-R-6855, CLASS II, GRADE 60

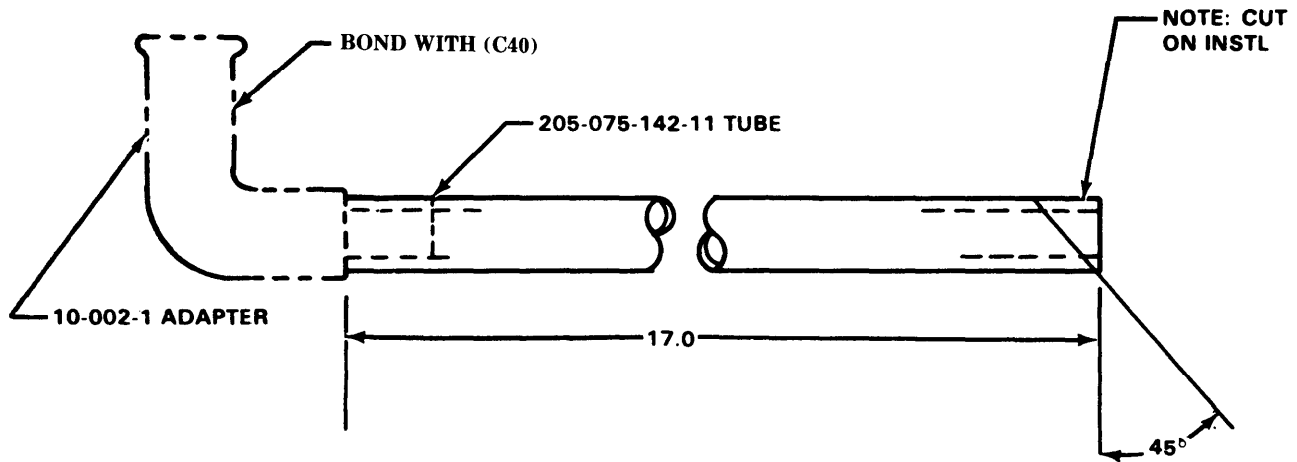
**Figure D-292.** Part Number 205-075-135-19 TUBE  
 Fabricate from: NSN 4720-00-540-3644  
 Material: Rubber Black Synthetic Federal Specification MIL-R-6855



**NOTES:**

1. PRIOR TO BOND CLEAN SURFACES WITH ACETONE CHEM PURE OR METHYL ETHYL KETONE CHEM PURE
2. ALTERNATE MAT'L :RUBBER-BLACK, MIL-R-6855, CLASS II - GRADE 60

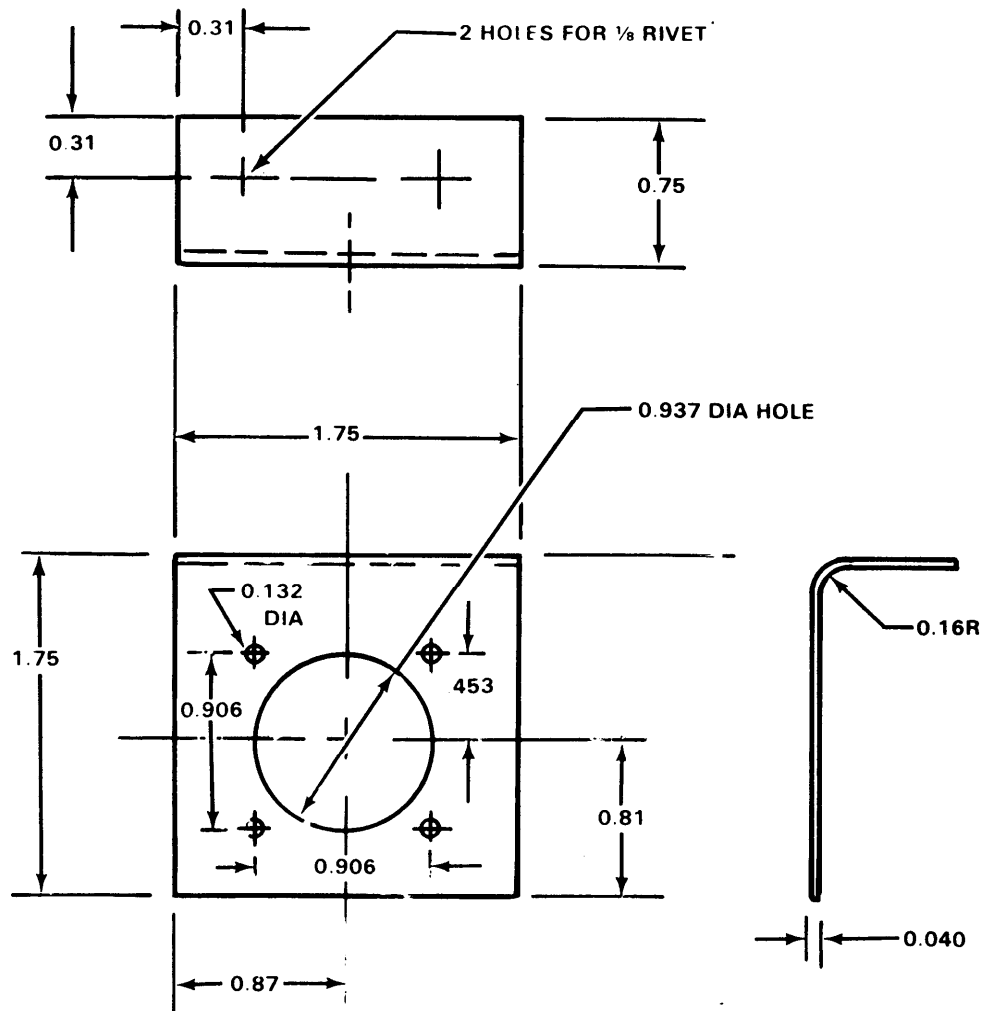
**Figure D-293.** Part Number 205-075-142-5 TUBE  
 Fabricate from: NSN 4720-00-540-3644  
 Material: Tubing Rubber Synthetic Black Federal Specification MIL-R-6855 Class 2 Grade 40, 1/8 Inch Wall Thick, 3/8 Inch ID



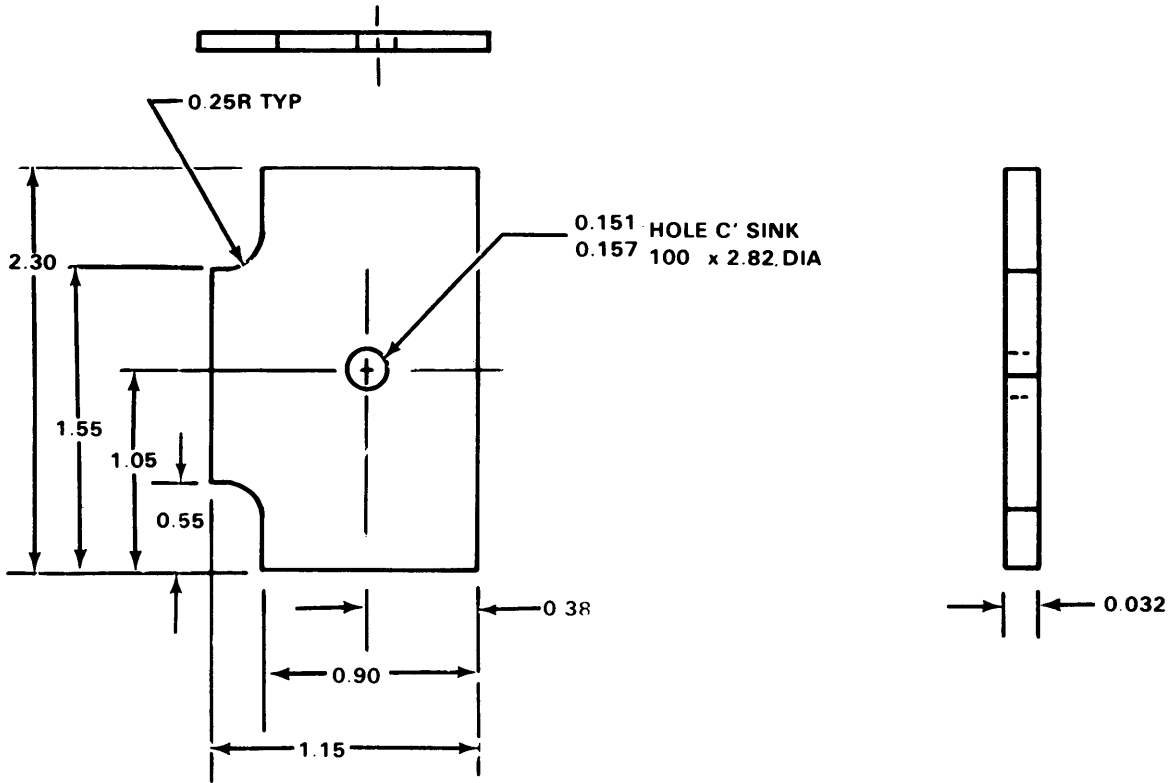
**NOTES:**

- 1. PRIOR TO BOND CLEAN SURFACES WITH ACETONE CHEM PURE OR METHYL ETHYL KETONE CHEM PURE**
- 2. ALTERNATE MAT'L: RUBBER-BLACK MIL-R-6855, CLASS II - GRADE 60**

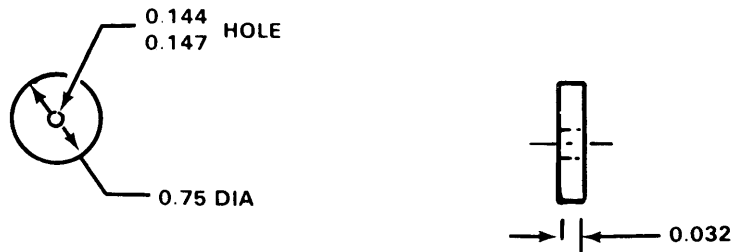
**Figure D-294.** Part Number: 205-75-142-9 TUBE  
Fabricate from: NSN 4720-00-540-3644  
Material: Tubing Rubber Synthetic Black  
Federal Specification MIL-R-6855 Class 2  
Grade 40, 1/8 Inch Wall Thick, 3/8 Inch I.D.



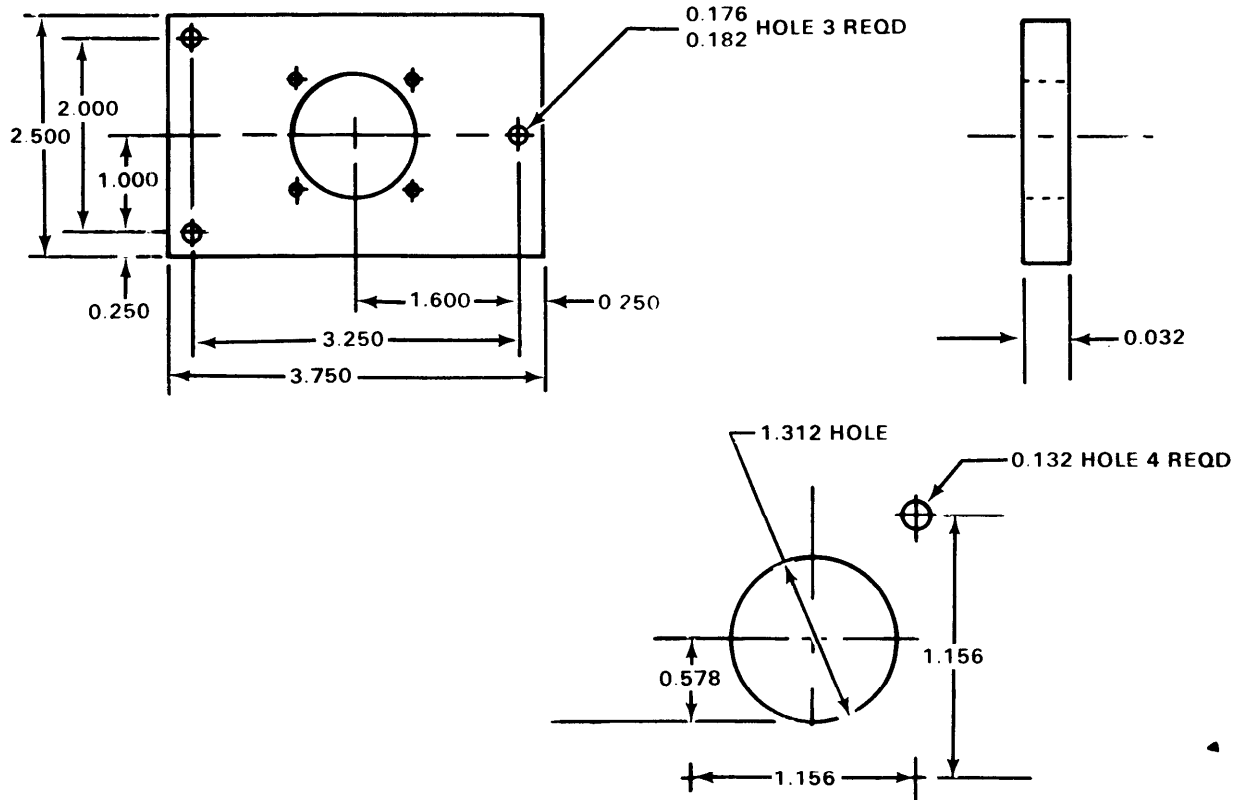
**Figure D-295** Part Number 205-075-151-1 BRACKET  
 Fabricate from: NSN 9535-00-232-0583  
 Material: 2024 AL ALY Sheet, Federal Specification QQ-A-250 T3,  
 0.040 Inch Thick, 2.2 Inch Wide, 3.0 Inch Long



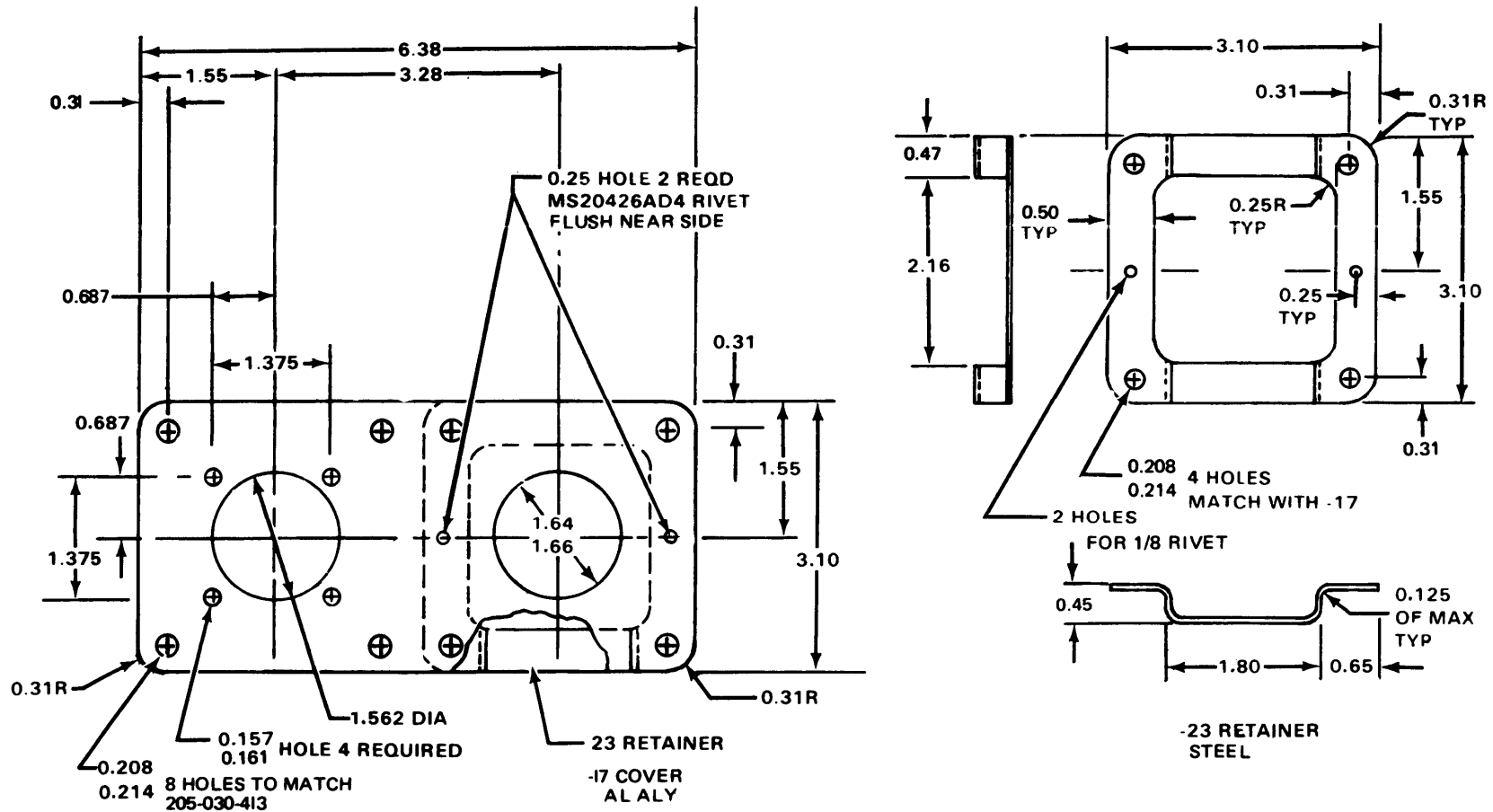
**Figure D-296.** Part Number 205-075-210-3 PLATE  
 Fabricate from: NSN 9535-00-167-2279  
 Material: 2024 AL ALY Federal Specification QQ-A-250/5,  
 0.032 Inch Thick, 2.5 Inch Wide, 2.5 Inch Long



**Figure D-297.** Part Number 205-075-210-5 PLATE  
 Fabricate from: NSN 9535-00-167-2279  
 Material: 2024 AL ALY Federal Specification QQ-A-250/5,  
 0.032 Inch Thick, 1.0 Inch Wide, 1.0 Inch Long

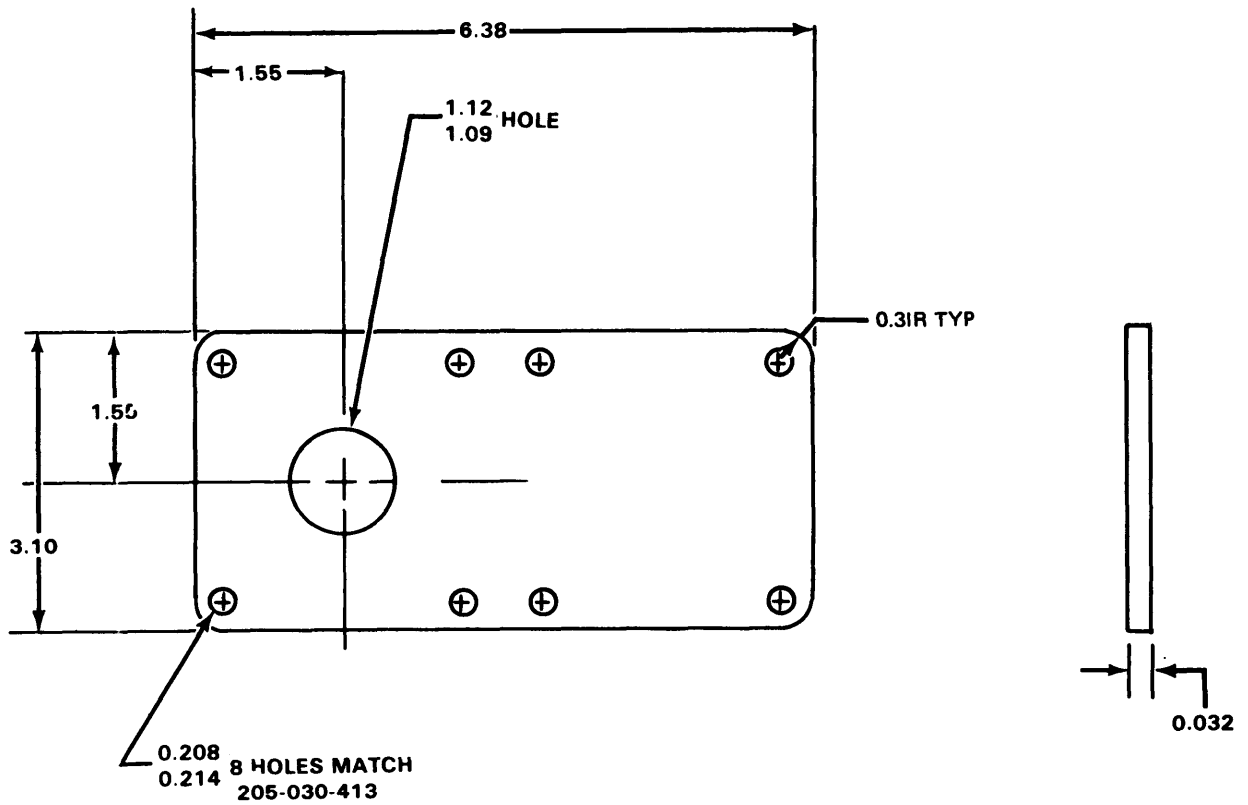


**Figure D-298.** Part Number: 205-075-237-5 PLATE RECEPTACLE  
 Fabricate from: NSN 9535-00-086-9729  
 Material: 2024 AL ALY, Federal Specification QQ-A-250/5, 0.032 Inch Thick, 2.7 Inch Wide, 4.0 Inch Long



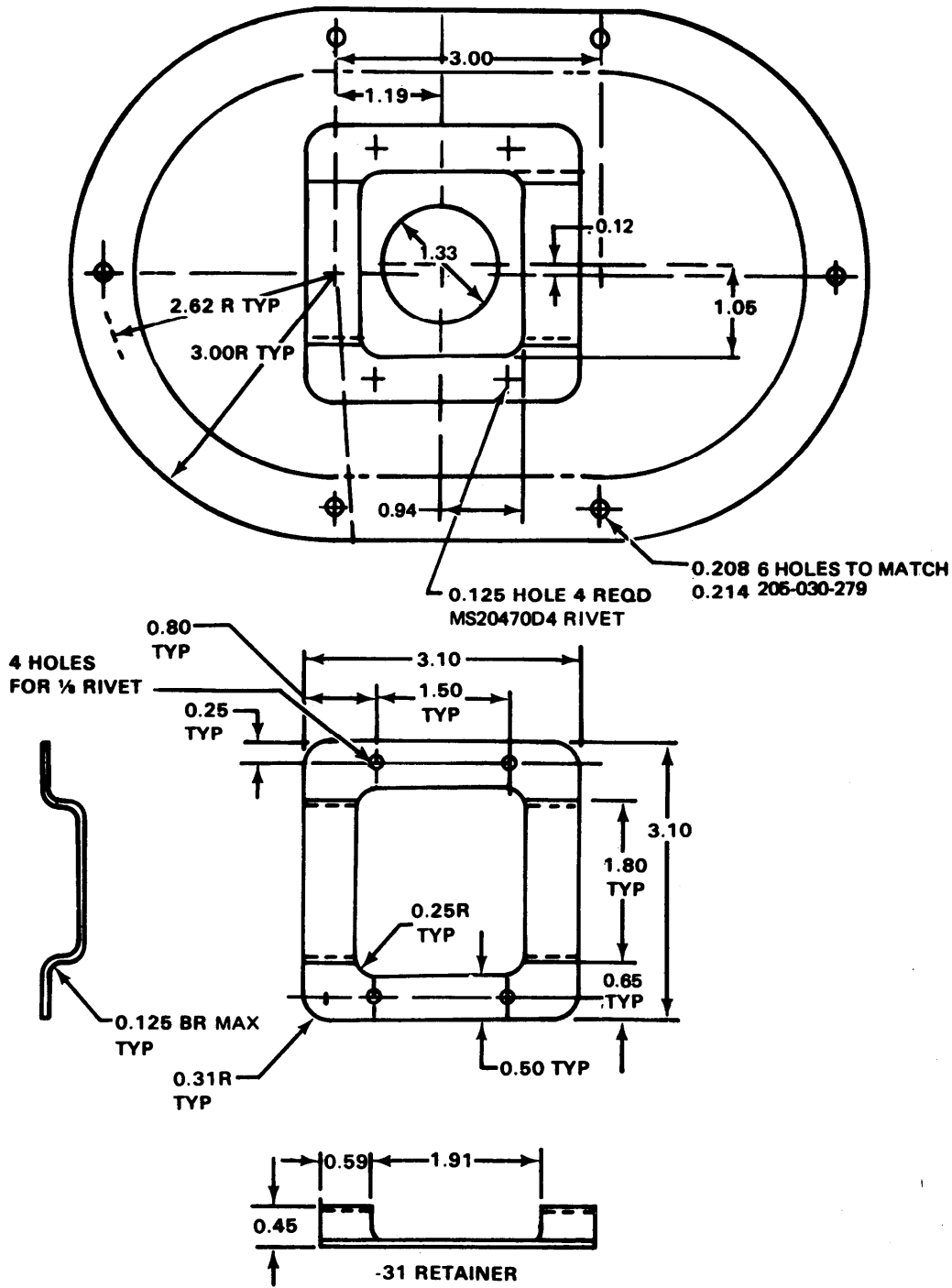
NOTES  
1 RIVET 205-961-102-23 RETAINER TO 205-961-102-17 COVER

**Figure D-299.** Part Number 205-961-102-17 COVER  
 Fabricate from: NSN 9535-00-086-9729, NSN 9515-00-683-9294  
 Material: 2024 AL ALY, Federal Specification QQ-A-250/5 T3,  
 0.032 Inch Thick, 3.3 Inch Wide, 6.6 Inch Long. Metal Sheet  
 Steel Corrosion, Federal Specification, MIL-S-5059 Comp 302,  
 Craw 18-18, 0.060 Inch Thick, 3.6 Inch Wide, 4.6 Inch Long

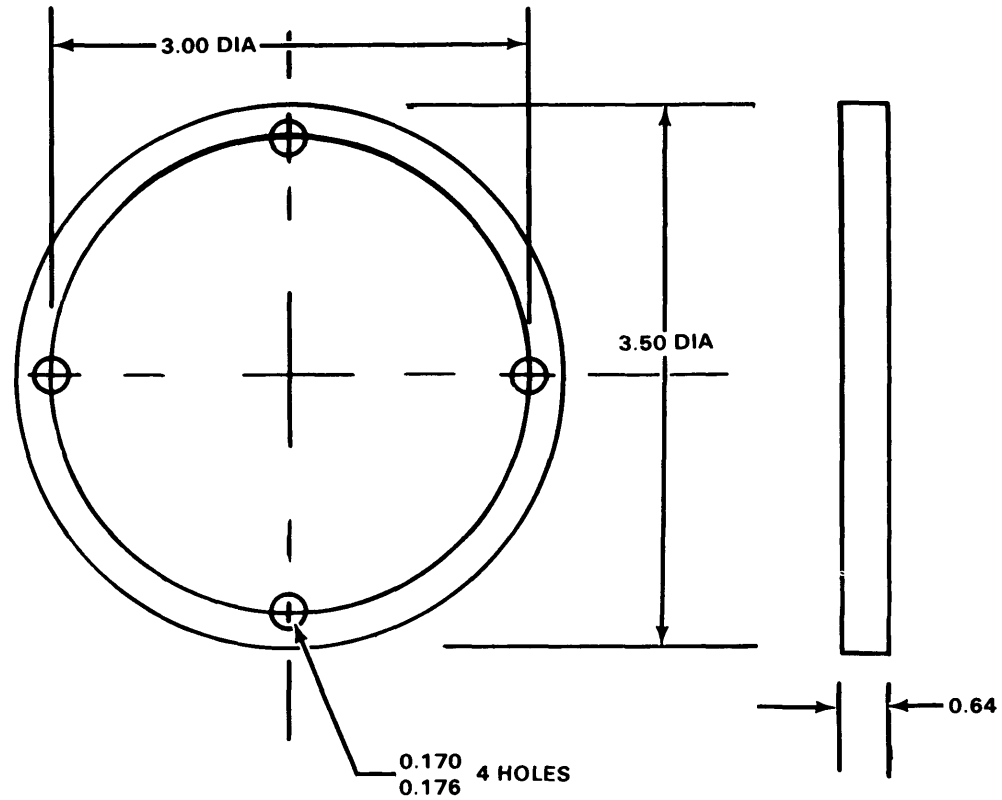


**Figure D-300.** Part Number 205-961-102-25 COVER  
 Fabricate from: NSN 9535-00-086-9729  
 Material: 2024 AL ALY, Federal Specification QQ-A-250/5 T3  
 0.032 Inch Thick, 3.3 Inch Wide, 6.6 Inch Long





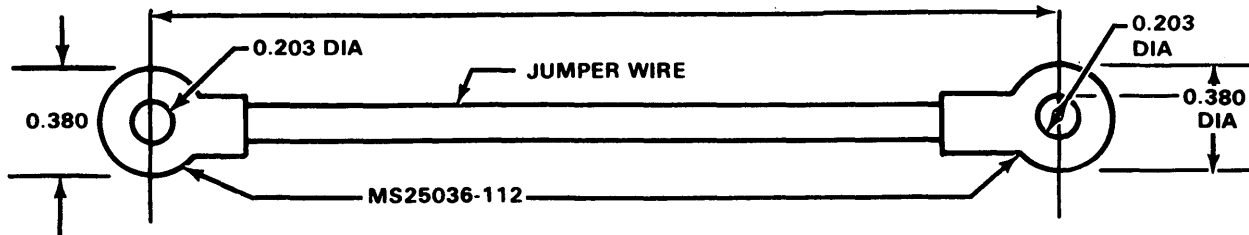
**Figure D-301.** Part Number 205-961-102-33 COVER  
 Fabricate from: Metal Sheet Steel Corrosion, Federal Specification MIL-S-5059 COMP 302, Annealed, CRES 18-8, 0.060 Inch Thick, 6.7 Inch Wide, 9.8 Inch Long, 3.16 Inch Wide, 4.6 Inch Long



**NOTES:**

1. 205-961-155-3 WINDOW MAKE FROM 0.064 INCH THICK POLYCARBONATE MATERIAL
2. PURCHASE FROM TEXAS WESTERN PLASTICS INC, 1824 INDUSTRIAL BLVD, DALLAS, TEXAS PER BELL HELICOPTER SPEC 299-947-044 AND FEDERAL SPECIFICATION L-P-393

**Figure D-302.** Part Number 205-961-155-3 WINDOW  
 Fabricate from: :NSN  
 Material: Polycarbonate Resin Material Federal Specification L-P-393 and Bell Helicopter SPEC 299-947-044, 0.064 Inch Thick, 4.0 Inch Wide, 4.0 Inch Long

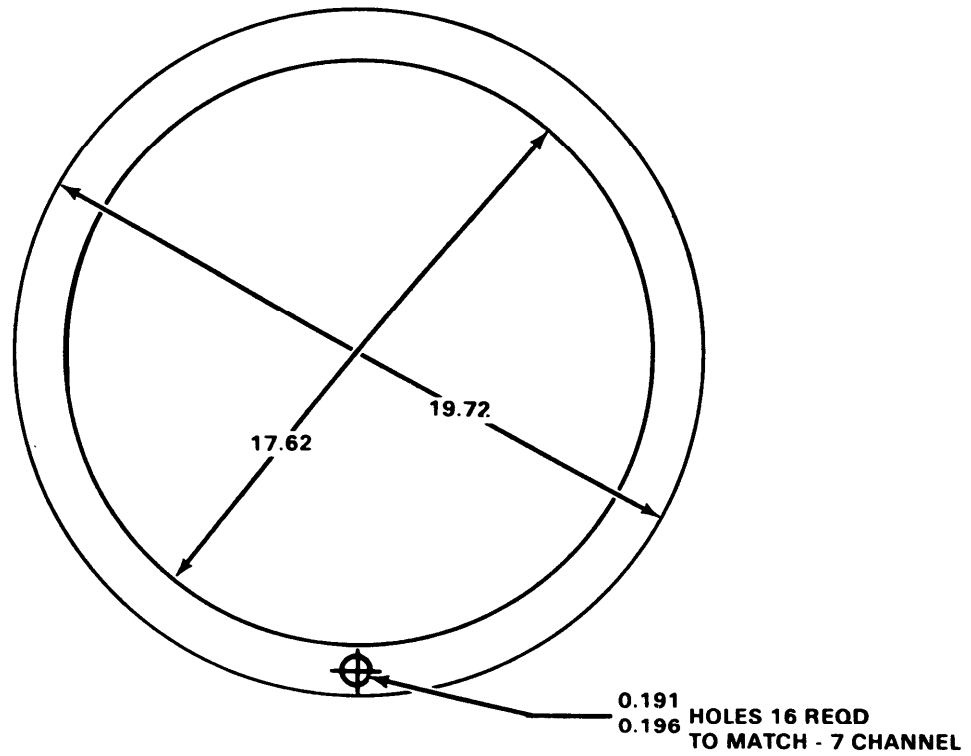


**NOTES:**

1. SECURE TERMINAL LUG AND BULK WIRE.
2. ATTACH TERMINALS TO COPPER WIRE WITH MS3316 OR MS17726 CRIMPING TOOLS AS APPLICABLE.

PART NO.	JUMPER WIRE	LENGTH
MS25083-2BB5	TINNED STRANDED COPPER	5.0
MS25083-2BB6	TINNED STRANDED COPPER	6.0

**Figure D-303.** Part Number MS25083-2BB5 JUMPER ASSY  
 MS25083-2BB6 JUMPER ASSY  
 Fabricate from: NSN 5940-00-143-4794  
 NSN 6145-00-819-0058  
 Material: Terminal Lug Copper (MS25036-112)  
 Wire, Electrical Copper Tinned, Federal  
 Specification QQ-W-343-TYPE RB Class 1, AWG 12



**NOTES:**

- 1. PURCHASE FROM JOHNS-MANSVILLE PRODUCTS  
NEW YORK, NEW YORK CODE IDENT 92798**

THICKNESS	SIZE	STYLE
0.047 INCH	20.00 x 20.00	89

**Figure D-304.** Part Number 204-060-816-33 GASKET  
 Fabricate from: NSN 5330-00-938-1719  
 Material:

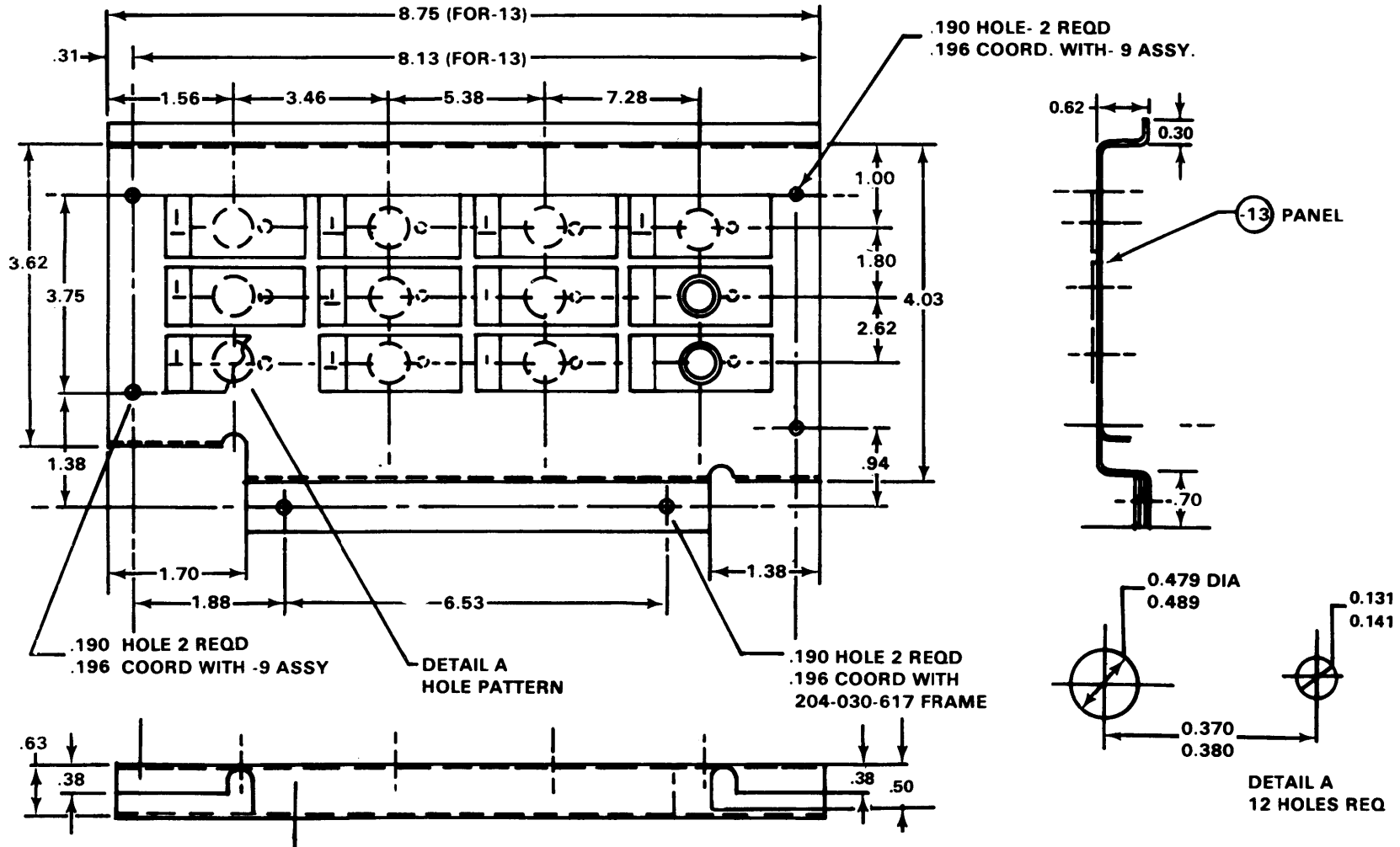
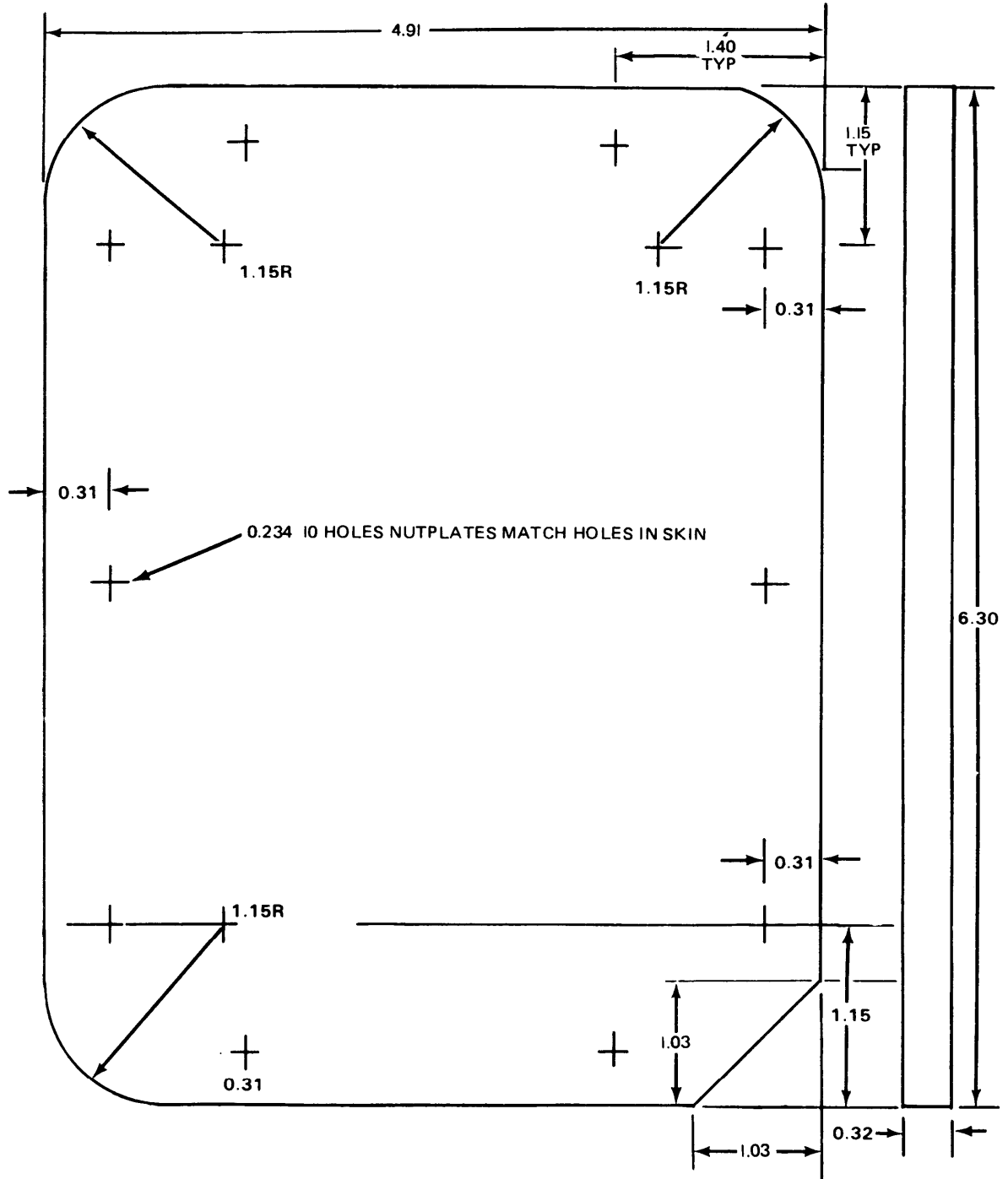
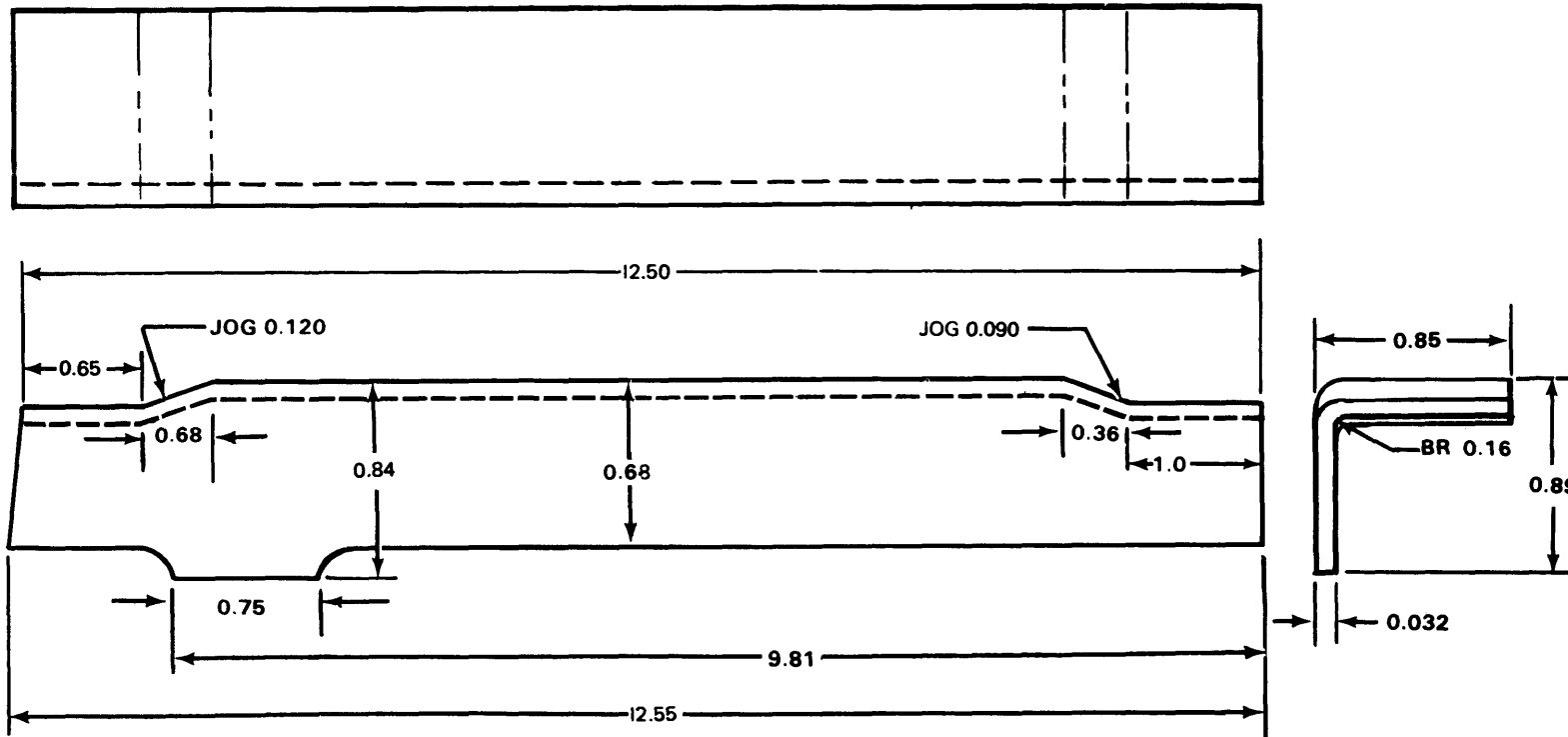


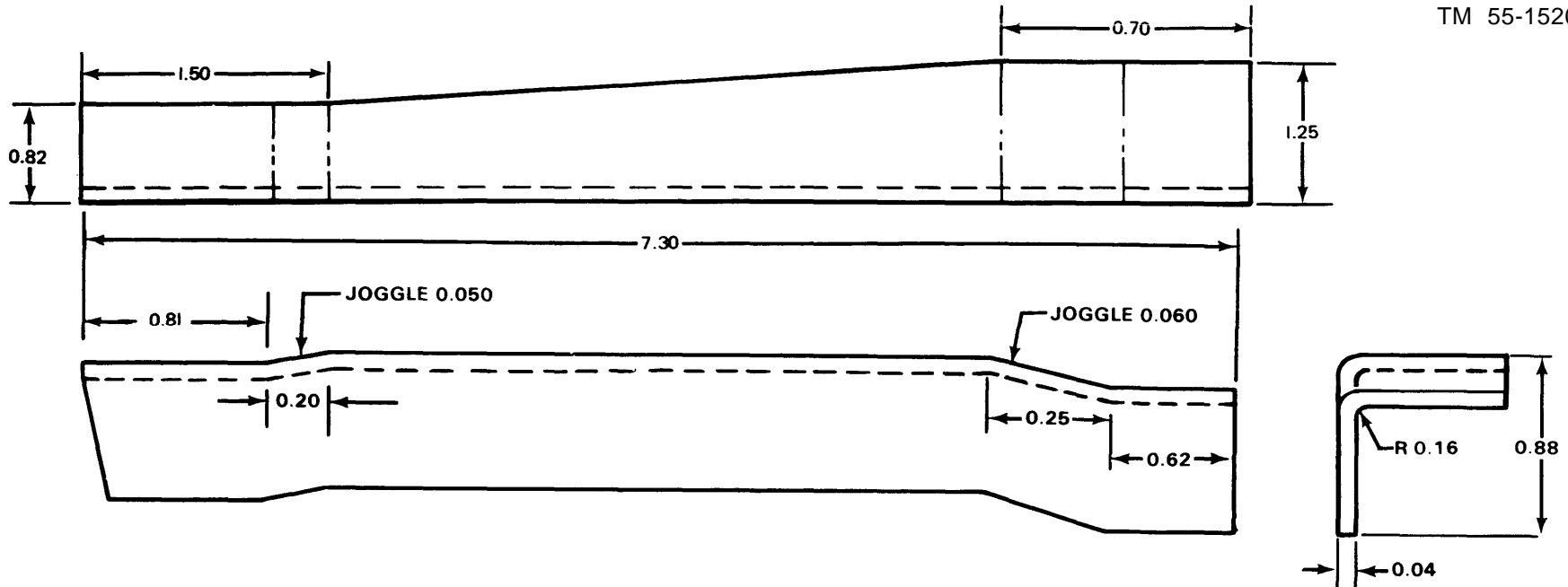
Figure D-305. Part Number 204-075-177-13 PANEL  
 Fabricate from: NSN 9353-00-086-9729  
 Material: 2024 AL ALY Federal Specification QQ-A-362, T3  
 0.032 Inch Thick, 6.8 Inch Wide, 9.3 Inch Long



**Figure D-306.** Part Number: 205-030-007-347 DOOR  
 Fabricate from: NSN 9535-00-086-9729  
 Material: 2024 AL ALY, Federal Specification QQ-A-250/5 T13,  
 0.032 Inch Thick, 5.5 Inch Wide, 6.8 Inch Long

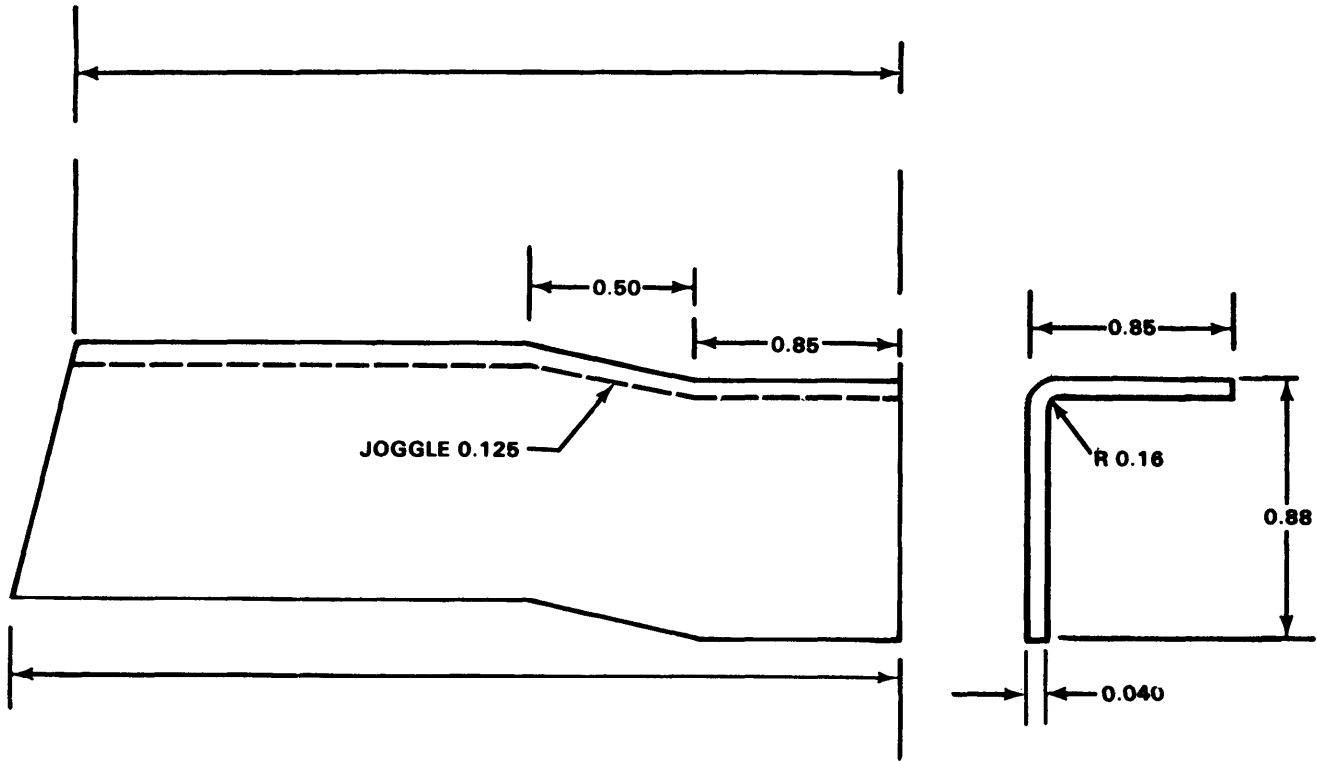


**Figure D-307.** Part Number: 205-030-163-25 ATTACHMENT  
 Fabricate from: NSN 9535-00-086-9860  
 Material: 7075 AL ALY, Federal Specification QQ-A-250/1 3 TO,  
 0.032 Inch Thick, 2.5 Inch Wide, 13.2 Inch Long

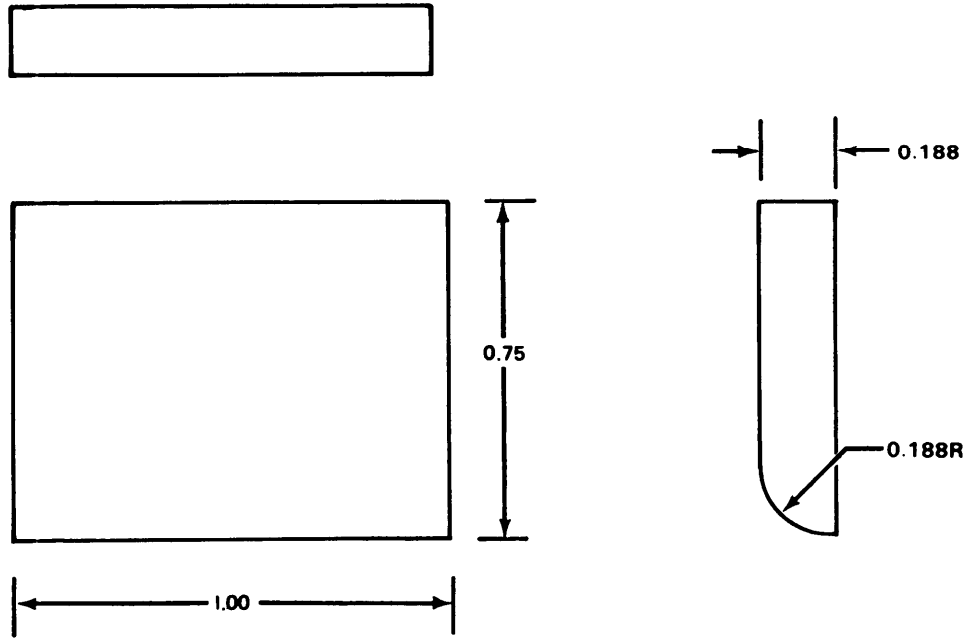


**Figure D-308.** Part Number: 205-030-163-125 ATTACHMENT  
 Fabricate from: NSN 9535-00-086-9860  
 Material: 2024 AL ALY, Federal Specification QQ-A-250/5 T3,  
 0.040 Inch Thick, 3.2 Inch Wide, 8.3 Inch Long

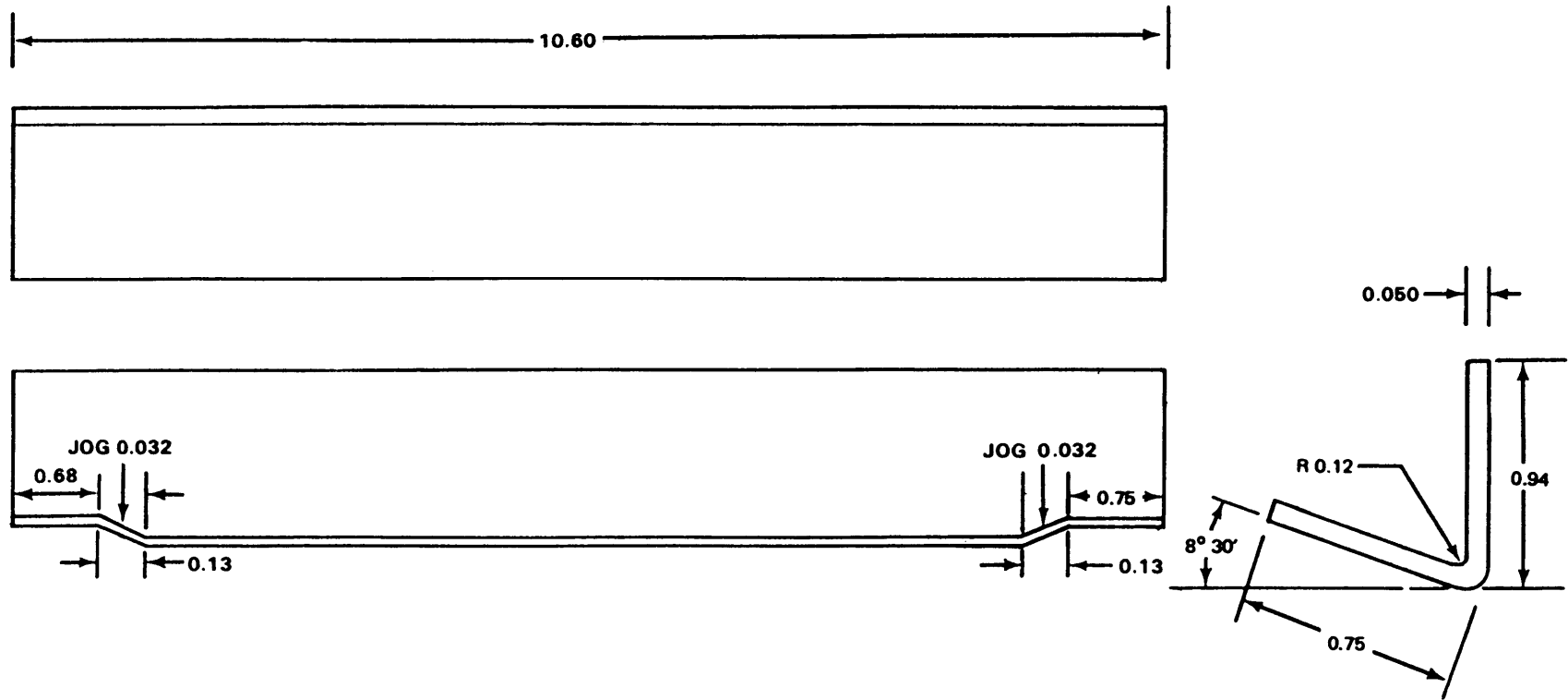




**Figure D-309.** Part Number: 205-030-163-129 ATTACHMENT  
Fabricate from: NSN 9535-00-084-4551  
Material: 2024 AL ALY Federal Specification QQ-A-250/5 T3,  
0.040 Inch Thick, 2.2 Inch Wide, 4.2 Inch Long



**Figure D-310.** Part Number: 205-030-163-231 RADIUS BLOCK  
Fabricate from: 9535-00-084-4516  
Material: 2024 AL ALY, Federal Specification QQ-A-250/5 T3,  
0.188 Inch Thick, 1.5 Inch Wide, 1.5 Inch Long



**Figure D-311.** Part Number 205-030-163-329 STIFFENER  
Fabricate from: NSN 9535-00-086-9456  
Material: 7075 AL ALY, Federal Specification QQ-A-250/13 TEMPO To T6  
0.050 Inch Thick, 2.5 Inch Wide, 11.2 Inch Long

Figure D-312

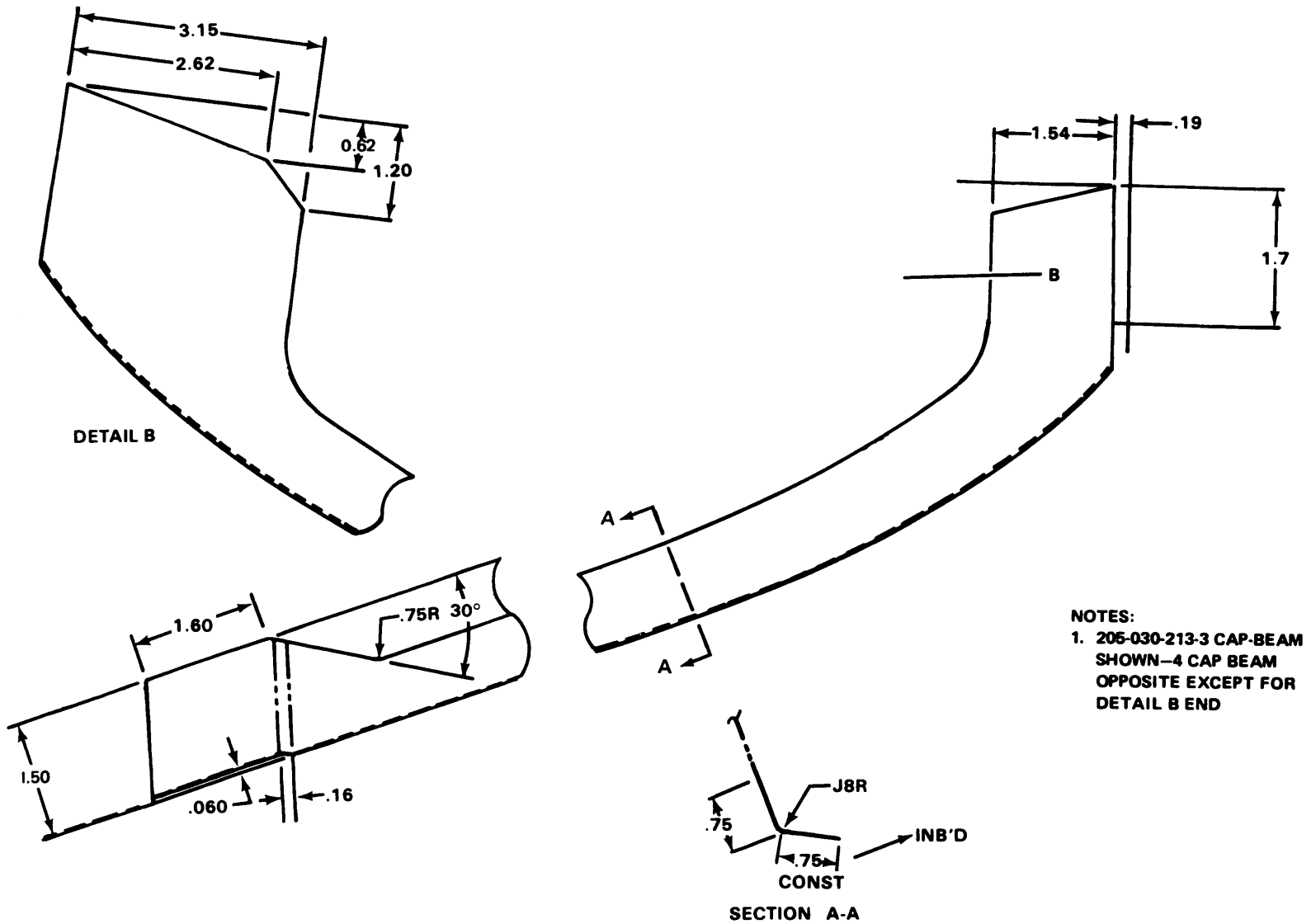
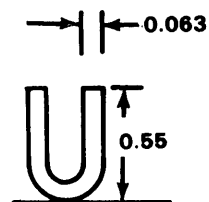
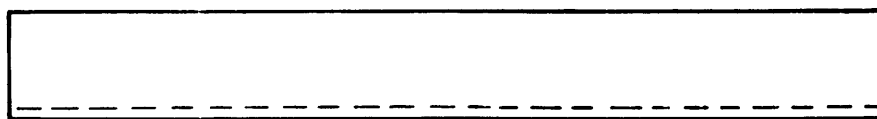


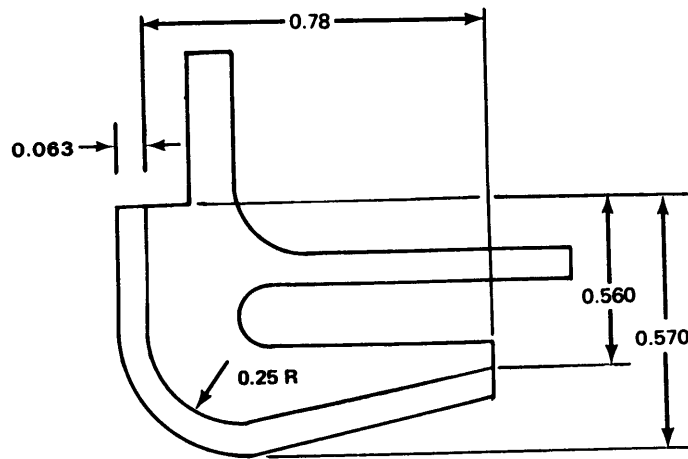
Figure D-312. Part Number 205-030-213-4 CAP-BEAM  
Fabricate From: NSN 9535-00  
Material: 2024 AL ALY, Federal Specification QQ-A-362-To, 0.032 Inch Thick, 3.4 Inch Wide, 40.0 Inch Long



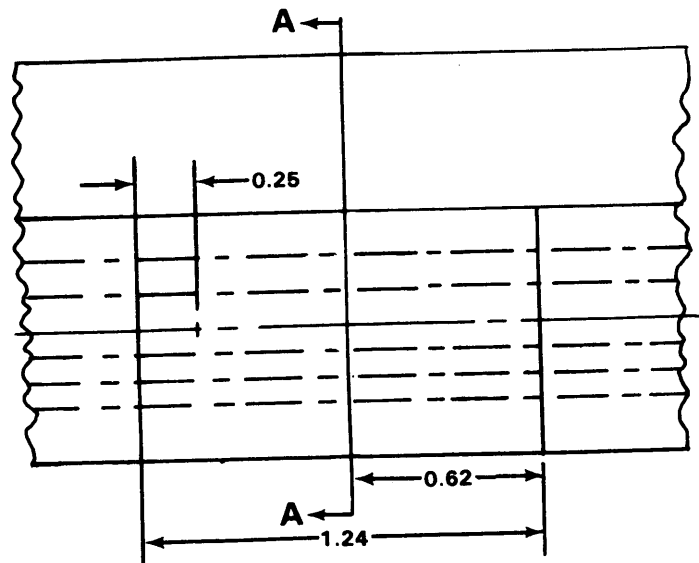
**NOTE:**

1. 205-030-385-17 GUIDE MAKE FROM FABRIC #6112 PURCHASE FROM SUMMER AND MACA GLASS MACHINERY CO. CHICAGO, ILL. CODE IDENT 55899
2. 205-030-385-17 GUIDE SHOWN —18 GUIDE OPPOSITE
3. CUT CLOTH TO DESIRED LENGTH 92.5 INCHES
4. BOND GUIDE TO TRACK WITH PROSEAL 584 ADHESIVE

**Figure D-313.** Part Number 205-030-385-18 GUIDE  
Fabricate from: NSN 8305-01-031-0130  
Material: Weather Strip; Cloth Fabric 0.063 Inch Thick,  
1.25 Inch Wide, 92.5 Inch Long



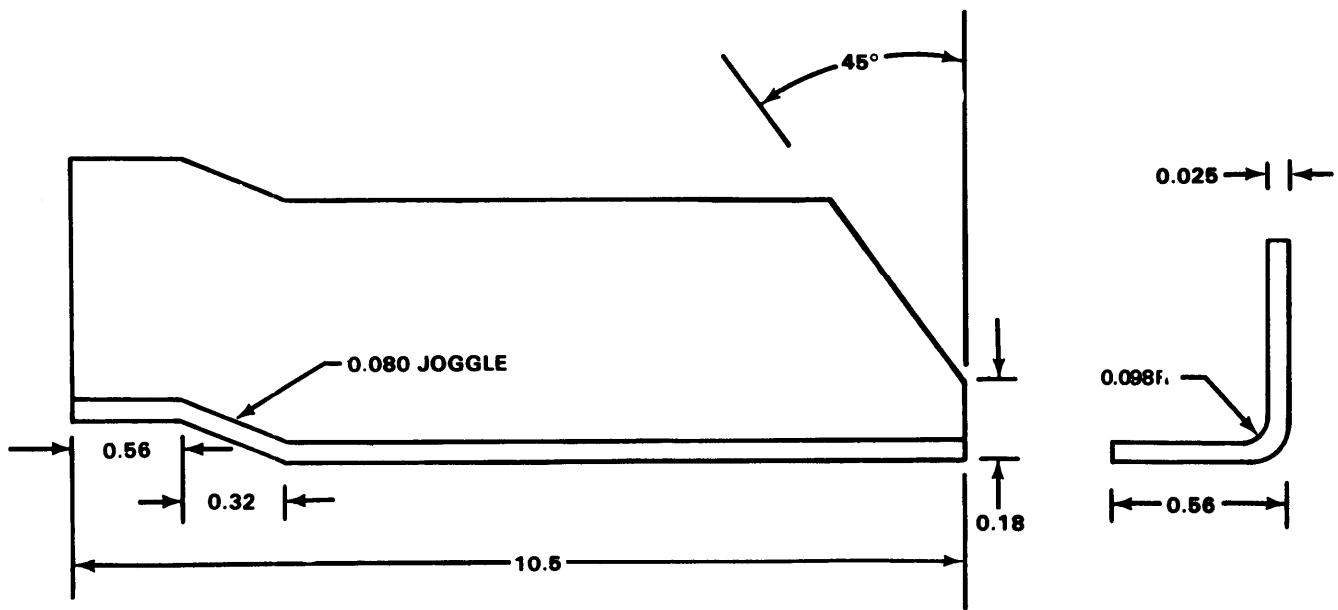
**Section A-A**



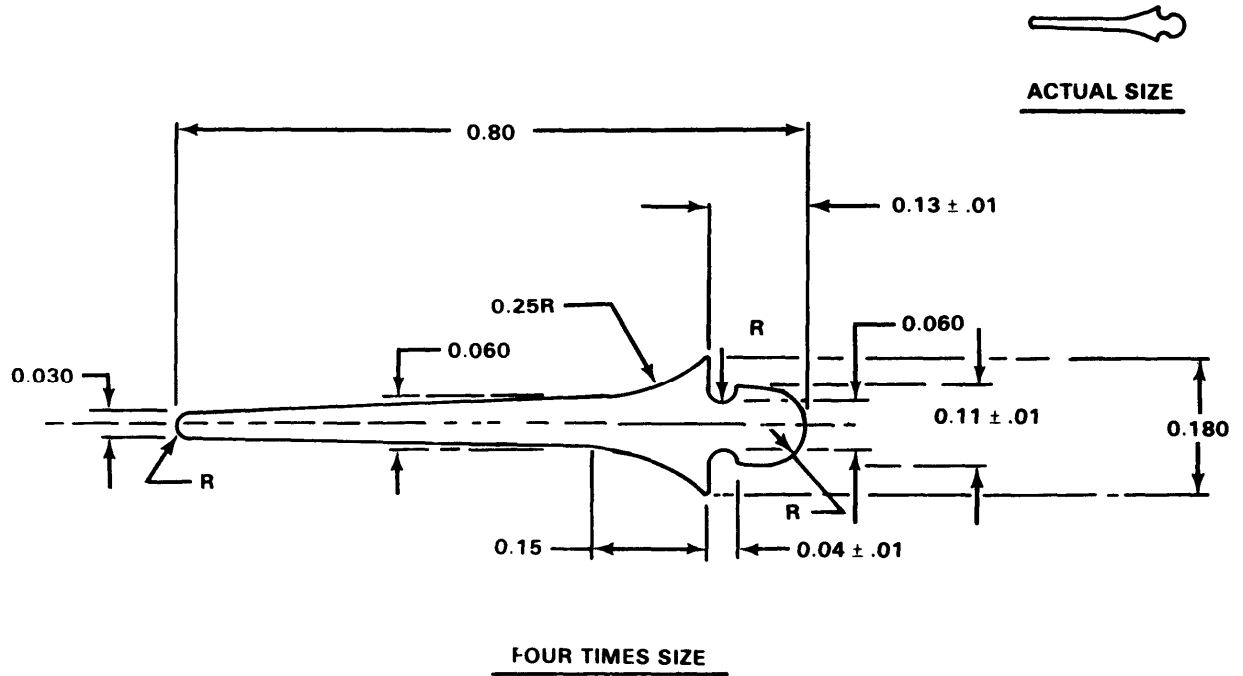
**NOTES:**

1. RIVET -21 DOUBLER TO TRACK WITH CR2248-4 RIVETS
2. BOND -21 DOUBLER TO TRACK WITH EPON 934 ADHESIVE

**Figure D-314.** Part Number 205-030-385-21 DOUBLER  
 Fabricate from: NSN 9515-00-234-7953  
 Material: Metal Steel Corrosion Resistant 18-8 Rolled, Annealed Federal Specification MIL-S-5059 Comp 301, 0.063 Inch Thick, 1.8 Inch Wide, 2.0 Inch Long



**Figure D-315.** Part Number: 205-030-407-121 ANGLE  
Fabricate from: 9635-00-167-2278  
Material: 2024 AL ALY Federal Specification QQ-A-250/5,T3,  
0.025 Inch Thick, 1.2 Inch Wide, 11.0 Inch Long

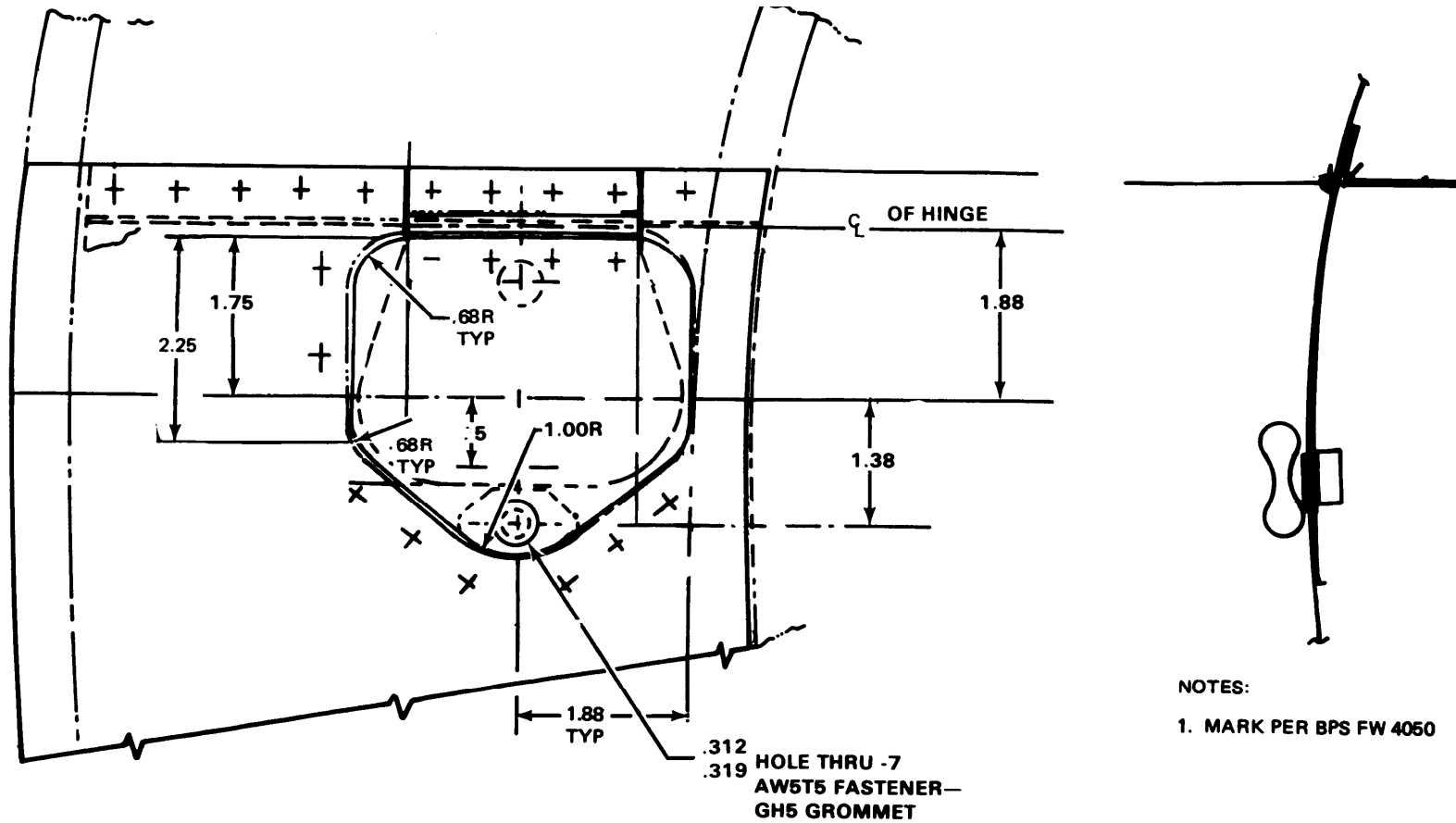


**NOTES:**

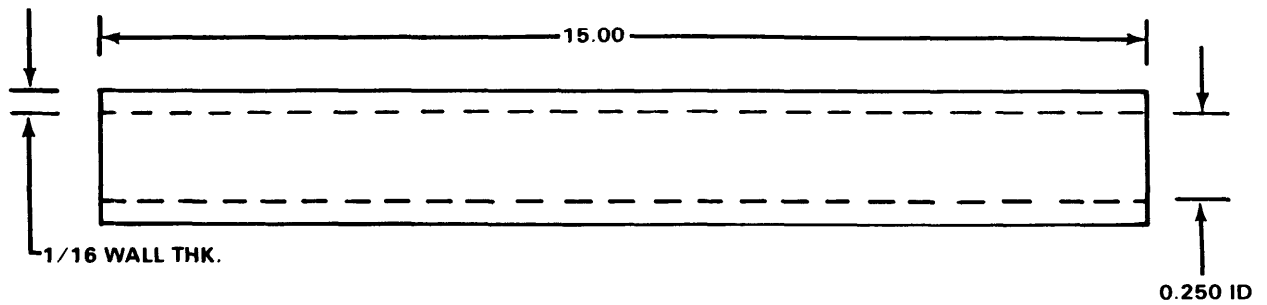
1. PART NO. 205-030-407-317 SEAL MAKE FROM BELL STD 110-032-1 MATERIAL 51.2 INCHES LONG
2. PURCHASE FROM BELL HELICOPTER OR BURKE RUBBER CO., 2250 SOUTH TENTH, SAN JOSE, CALIFORNIA.

**Figure D-316.** Part Number 205-030-407-317 SEAL  
 Fabricate from: NSN 5340-00-949-8281  
 Material: Extruded Silicone Rubber, Bell Specification 299-947-095, Color Black or Grey

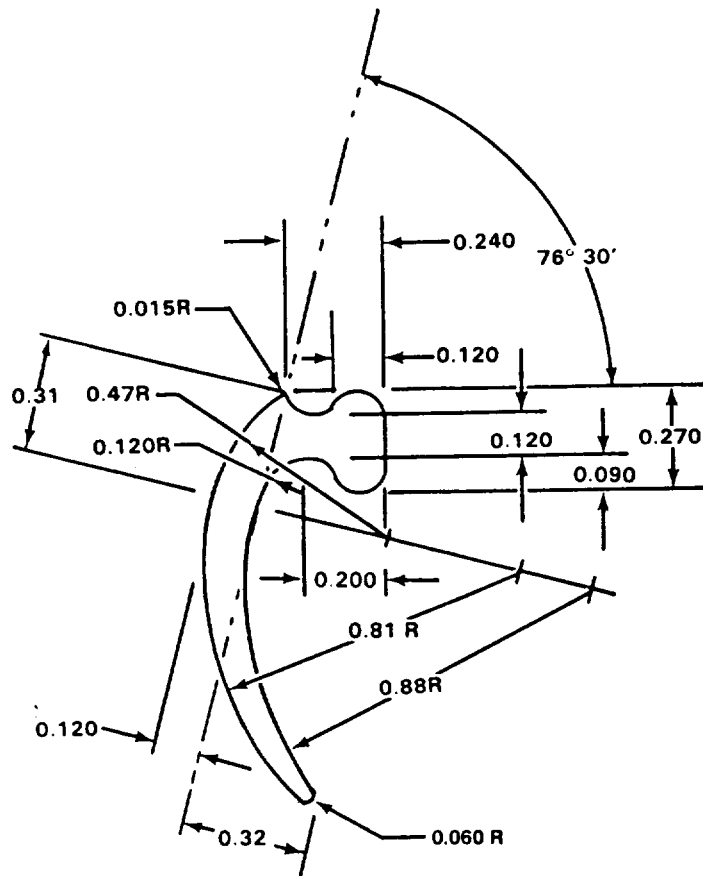




**Figure D-317.** Part Number 205-030-539-7 DOOR  
 Fabricate from: NSN 9535-00-167-2278  
 Material: 2024 AL ALY, Federal Specification QQ-A-250/5, T3,  
 0.025 Inch Thick, 4.0 Inch Wide, 4.5 Inch Long



**Figure D-318.** Part Number 205-030-611-15 TUBE  
 Fabricate from: NSN 4720-00-235-5455  
 Material: Hose, Rubber Synthetic, Federal Specification MIL-R-6855,  
 Class V 1/4 ID, 1/16 Wall Thk. 15.0 Inch Long



NOTES:

1. PART NO. 205-030-615-93 AND -94  
MAKE FROM BELL STD 110-015-1  
MATERIAL BOTH ITEMS 98.00 INCH LONG.
2. PURCHASE FROM BELL HELICOPTER OR  
BURKE RUBBER CO. 2250 SOUTH TENTH,  
SAN JOSE, CALIFORNIA

Figure D-319. Part Number

205-030-615-93-SEAL

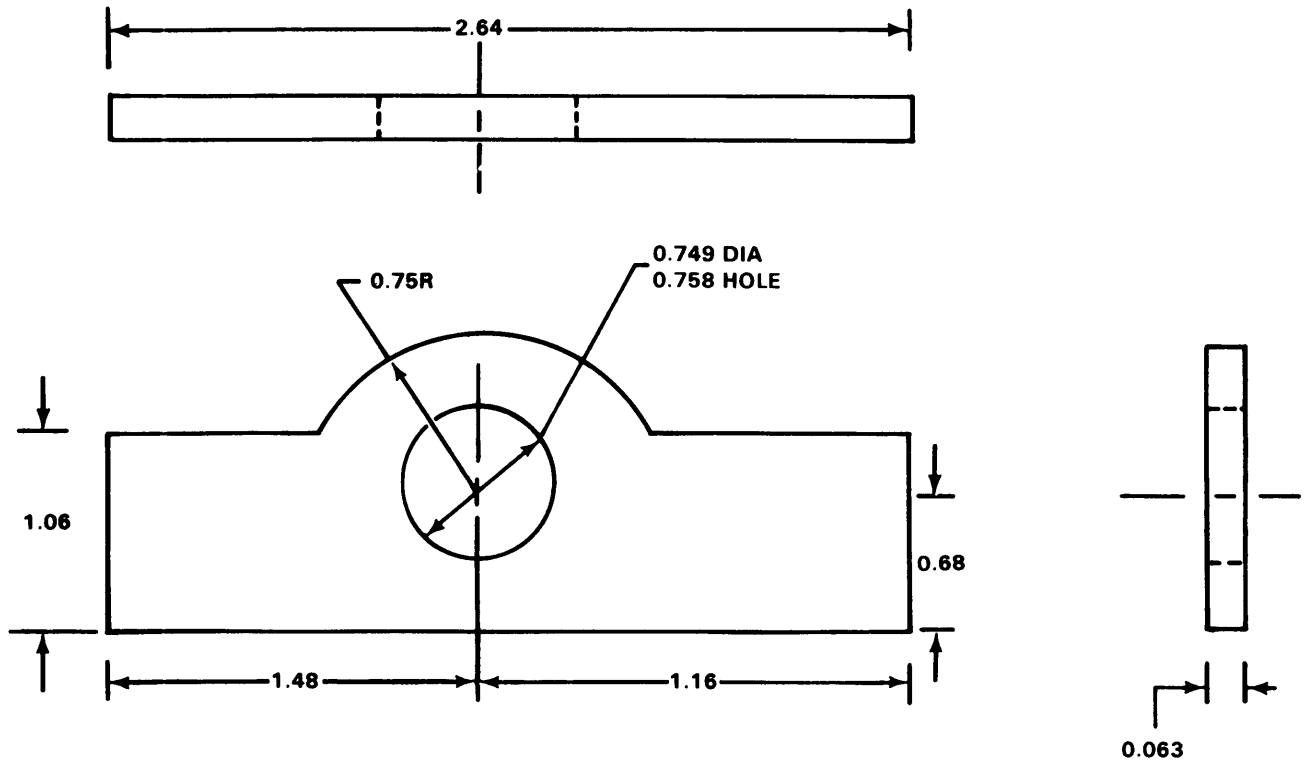
205-030-615-94-SEAL

Fabricate from:

9390-00-877-6254

Material:

Extrusion-Rubber, Door Seal Bell Specification  
299-947-095 Color Black or Grey

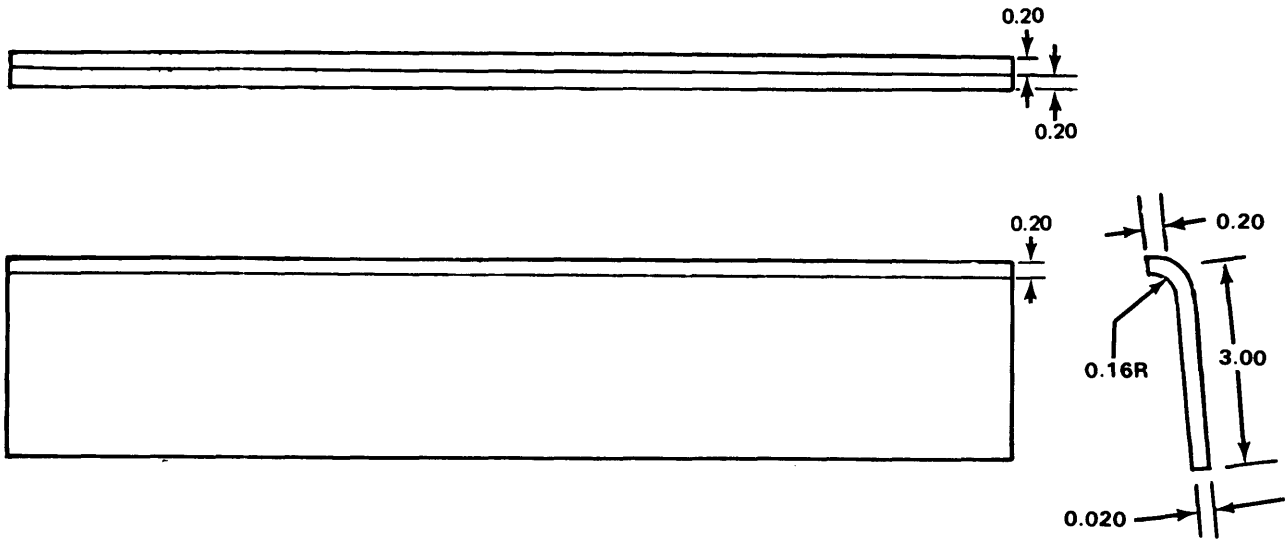


**NOTES:**

**LOCATE CENTER HOLE TO MATCH  
205-031-669-141, AND -143 SUPPORT**

**Figure D-320. Part Number  
Fabricate f rem:  
Material:**

**206-031-669-137 DOUBLER  
NSN 9536-00-664-1417  
2024 AL ALY Federal Specification QQ-A-250/5, T3,  
0.063 Inch Thick, 2.0 Inch Wide, 3.4 Inch Long**



**NOTES:**

205-030-711-27 CAP STRIP SHOWN  
205-030-711-28 CAP STRIP OPPOSITE

Figure D-321. Part Number: 205-030-711-27 CAP STRIP  
205-030-711-28 CAP STRIP  
Fabricate from: NSN 9536-00-232-7636  
Material: 7075 AL ALY Federal Specification QQ-A-250/I3, T6,  
0.020 Inch Thick, 3.2 Inch Wide, 16.8 Inch Long.

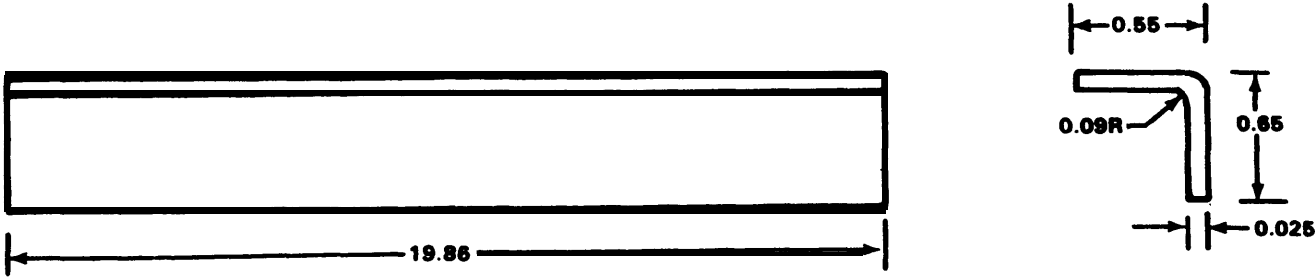
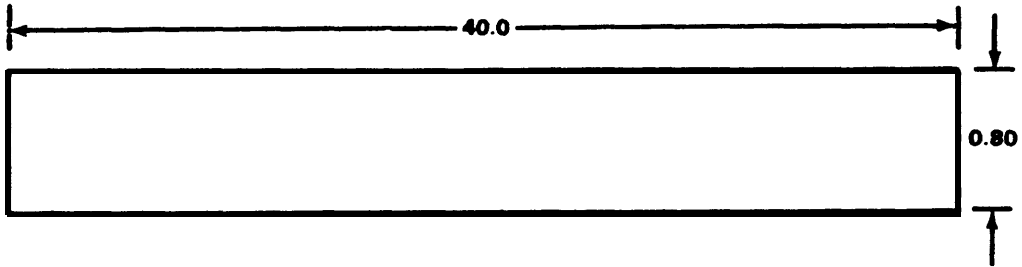
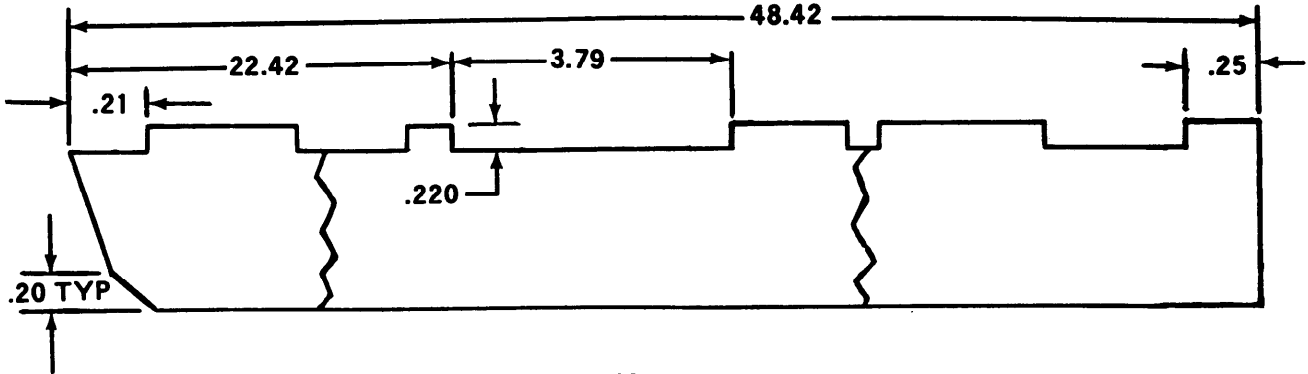


Figure D-322 Put Number 206-030-729-49 SUPPORT COVER  
 Fabricate from: NSN 9535-00  
 Material 2024 AL ALY, Federal Specification QQ-A-250/5. T3.  
 0.026 inch Thick 1.7 inch Wide, 20.4 Inch Long



- NOTES:
1. PART NO. 206-030-819-21 MAKE FROM ANTI-CHAFFING TAPE #366. 0.80 INCH WIDE, 40.0 INCH LONG PURCHASE FROM MINNESOTA MINING AND MFG COMP ST PAUL MINN. CODE IDENT 76381
  2. ALTERNATE MATERIAL FOR ANTI-CHAFFING TAPE #649-3% MILLS PURCHASE FROM MINNESOTA MINING AND MFG. COMP, ST PAUL, MINN. CODE IDENT 76381

Figure D-323. Part Number 205-030-819-21 STRIP-CHAFFING  
 Fabricate from: TAPE, ANTI-CHAFFING #366, 0.80 Inch Wide,  
 Material 40.0 Inch Long

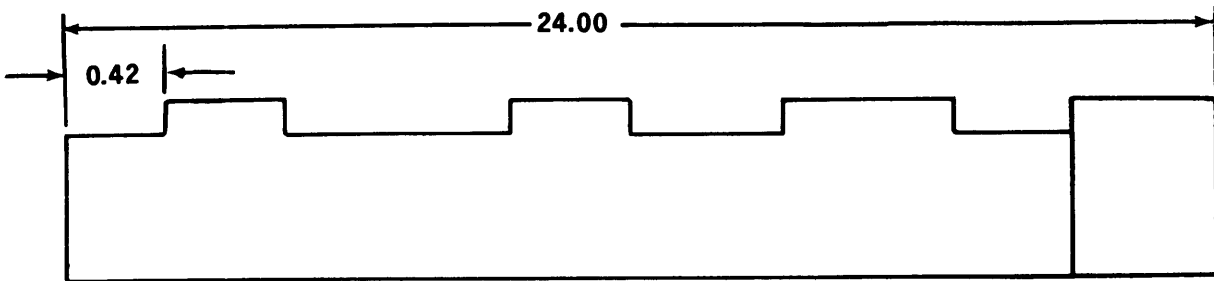


NOTES:

1. 205-030-846-33S HINGE MAKE FROM MS20001PH4-7200 LEAF BUTT HINGE MATERIAL
2. CUT HINGE MATERIAL TO PROPER LENGTH 49.00 INCH LONG
3. DESIGNATION S IS SYNTHETIC PART NO.

Figure D-324.

Part Number: 295-030-846-33S HINGE  
 Fabricate from: NSN 5340-00-949-8274  
 Material: HINGE, BUTT AL ALY Anodized 0.056 Inch Thick, 0.495 Inch Wide, 72.00 Inch Long

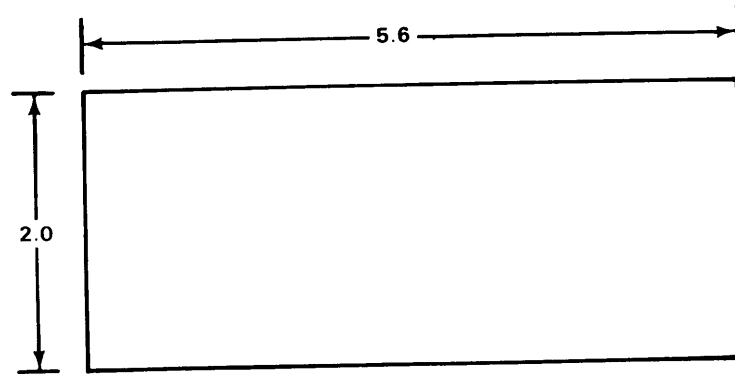


NOTES:

1. PART NO. 205-030-850-21 HINGE HALF MAKE FROM MS20257HP2-7200 STOCK
2. CUT HINGE MATERIAL TO THE REQUIRED LENGTH 24.00 INCH LONG

Figure D-325.

Part Number: 205-030-850-21 Hinge Half  
 Fabricate from: NSN 5340-00-993-1461  
 Material: Leaf, Butt Hinge - Aluminum Alloy Anodized, 0.040 Inch Thick, 0.531 Inch Wide, 72.00 Inch Long



**NOTES:**

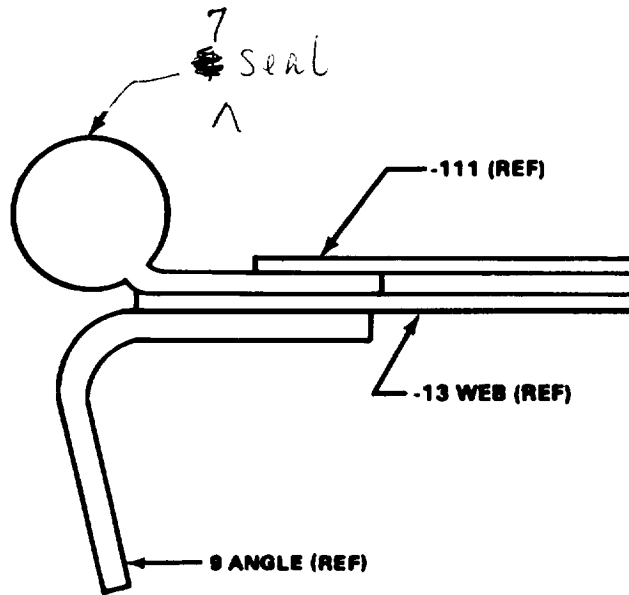
1. PART NO. 205-060-826-79 GRIP  
MAKE FROM SCOTCH-TRED COLOR  
GREY PURCHASE FROM MINNESOTA  
MINING AND MFG. CO. ST. PAUL,  
MINN. (CODE IDENT NO 76381)
2. ATTACH GRIP MATERIAL TO COWL  
ASSY. HAND HOLD.

**Figure D-326.**

**Part Number**  
**Fabricate from:**  
**Material:**

**205-060-826-79 GRIP**  
**NSN 7220-00-206-0390**  
**Cloth Material, Adhesive Backing One Side,**  
**Abrasive Material Other Side, Scotch Tred Color Grey**





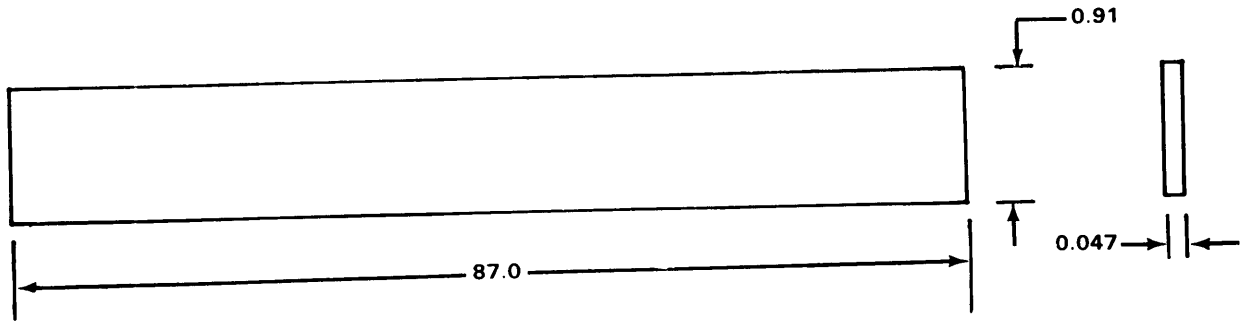
NOTES

1. 206-060-909-7 SEAL MARK FROM  
3/8 DIA BULB, TADPOLE SEAL, FIREWALL  
1.2 INCH WIDE, 87.0 INCH LONG
2. PURCHASE SEAL FROM JOHNS-MANSVILLE  
COMP, NEW YORK N.Y. CODE IDENT 92788

Figure D-327.

Part Number  
Fabricate from:  
Material:

206-060-909-7 SEAL  
NSN 9390-00-861-9178  
SEAL, Bulb 3/8 Inch Dia, Firewall Seal



**NOTES:**

1. MARK PER BPS FW 4050
2. PURCHASE FROM JOHNS-MANSVILLE PRODUCTS CO., NEW YORK, N.Y. CODE IDENT 92789
3. SPECIAL ASBESTOS MATERIAL

THICKNESS	SIZE	STYLE
0.047 INCH	1.9 X 87.0 INCH	# 89

Figure D-328. Part Number 205-060-909-17 GASKET  
 Fabricate from: NSN 5330-00-938-1719  
 Material: GASKET, Asbestos Material 0.047 Inch Thick, 1.9 Inch Wide, 87.0 Inch Long

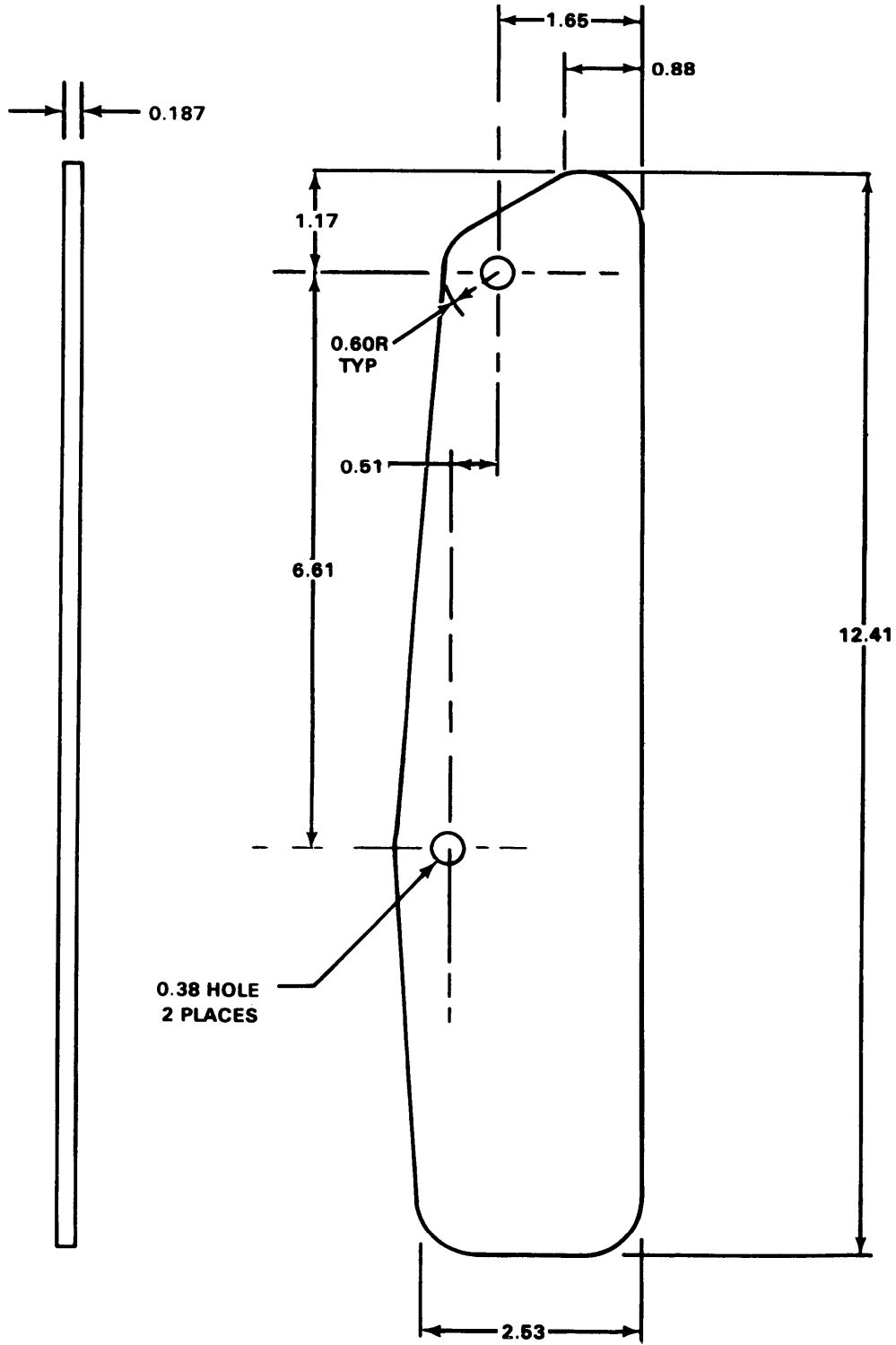


Figure D-329.

Part Number: 205-061-232-1 SEAL  
Fabricate from: NSN 9320-00-466-1884  
Material: Closed Cell Medium Sponge Federal Specification AMS-3195,  
0.187 Inch Thick, 3.2 Inch Wide, 13.0 Inch Long

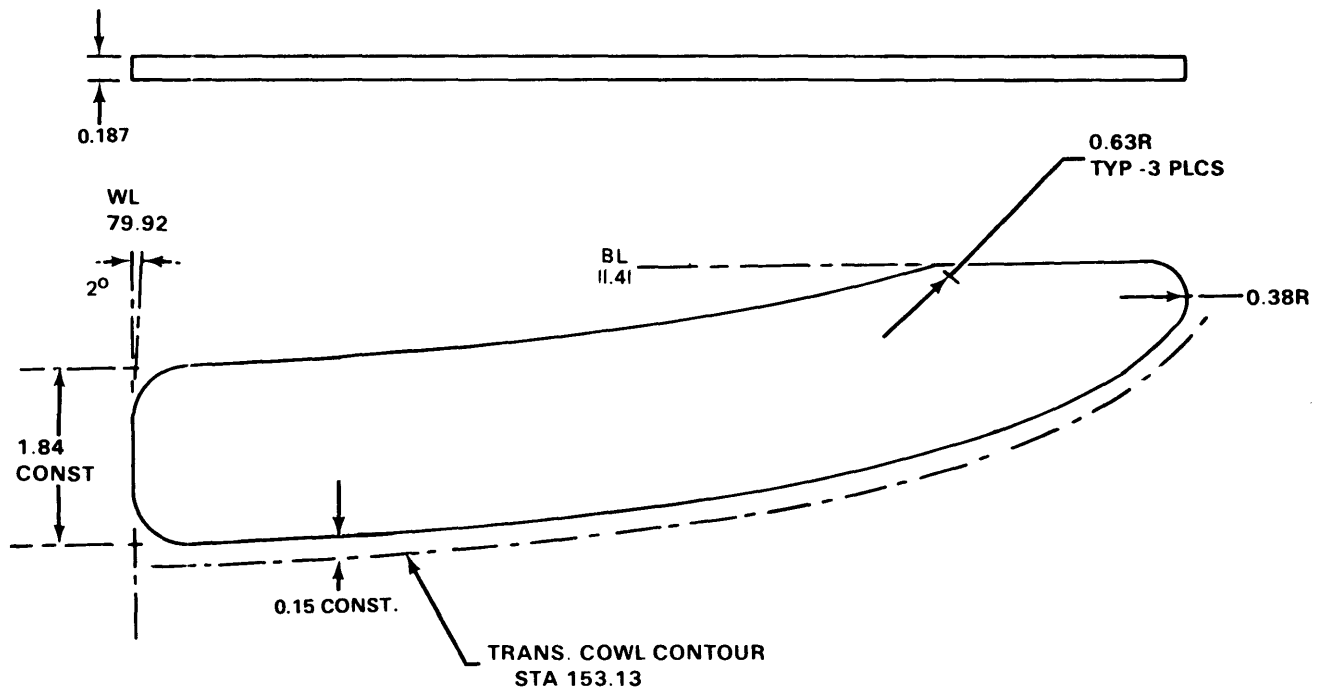


Figure D-330.

Part Number: 205-061 -234-1 SEAL FORWARD  
 Fabricate from: NSN 9320-00-456-1804  
 Material: Closed Cell Medium Sponge, Federal Specification AMS-3195,  
 0.187 Inch Thick, 3.0 Inch Wide, 13.5 Inch Long

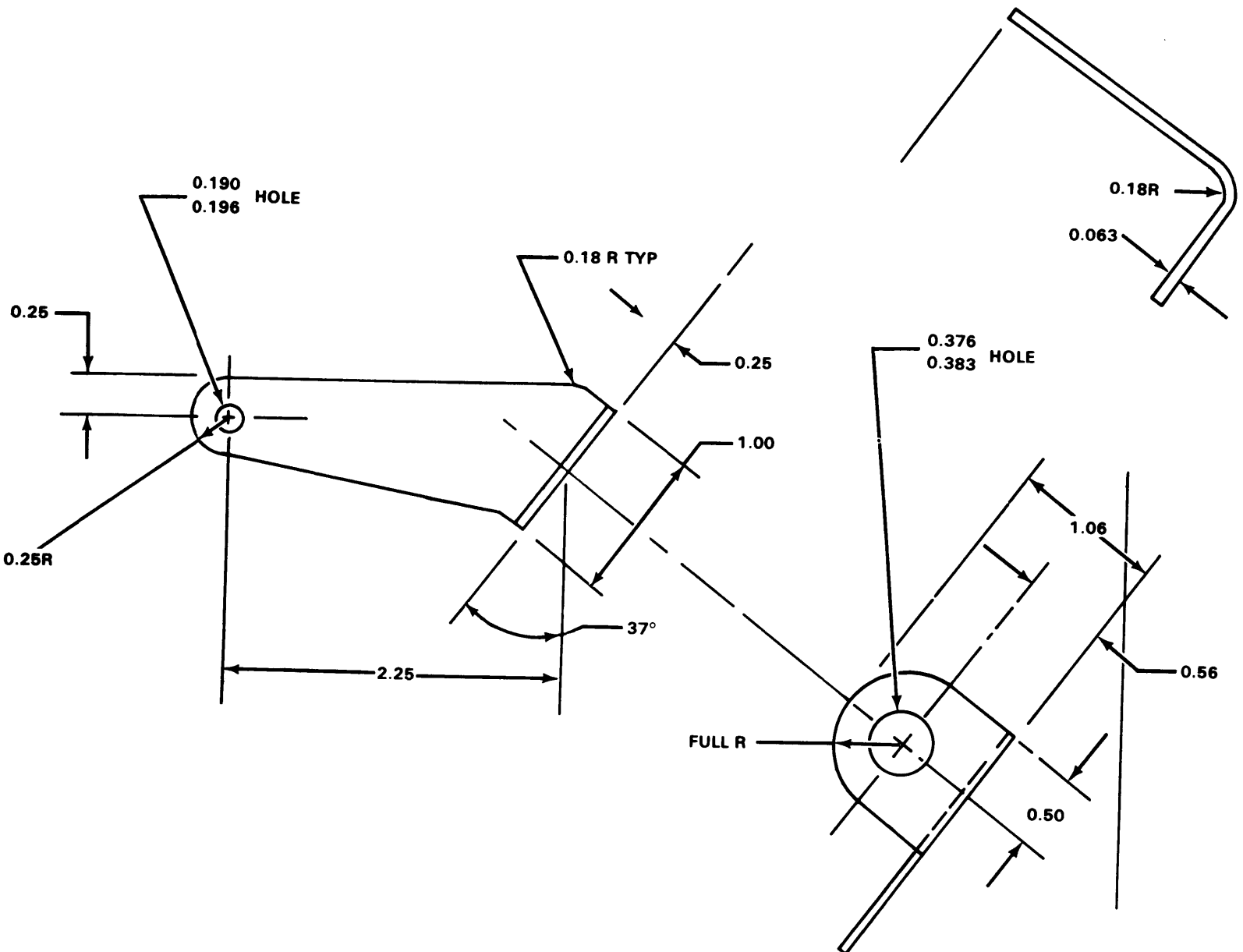


Figure D-331.

Part Number

205-061-412-1 Bracket

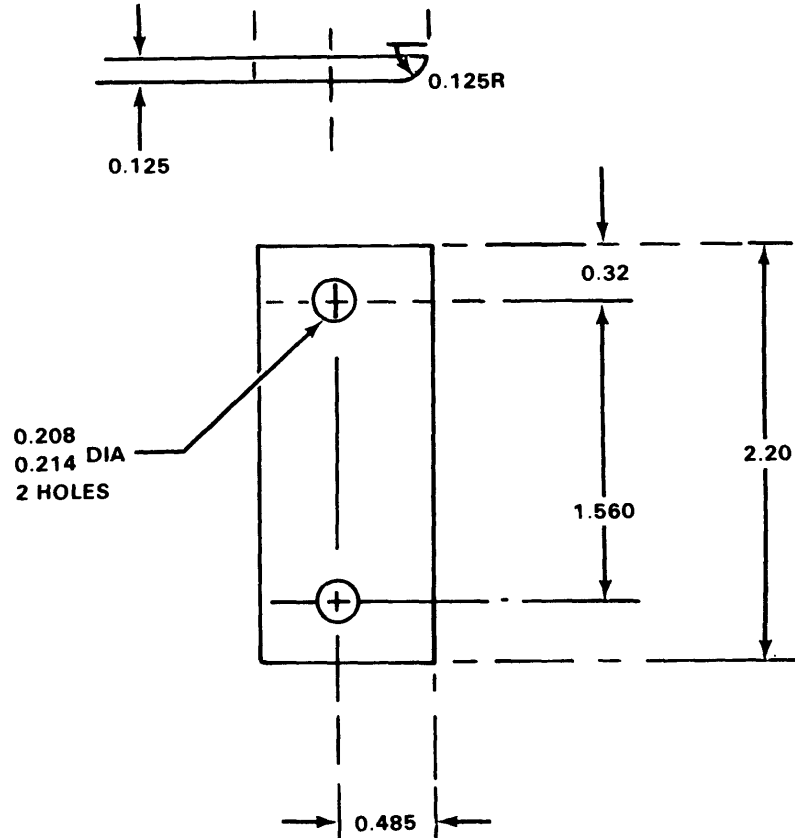
Fabricate From:

NSN 9535-00-554-1417

Material:

2024 AL ALY, Federal Specification QQ-A-250 5 T3,

0.063 Inch Thick, 2.2 Inch Wide, 4.0 Inch Long



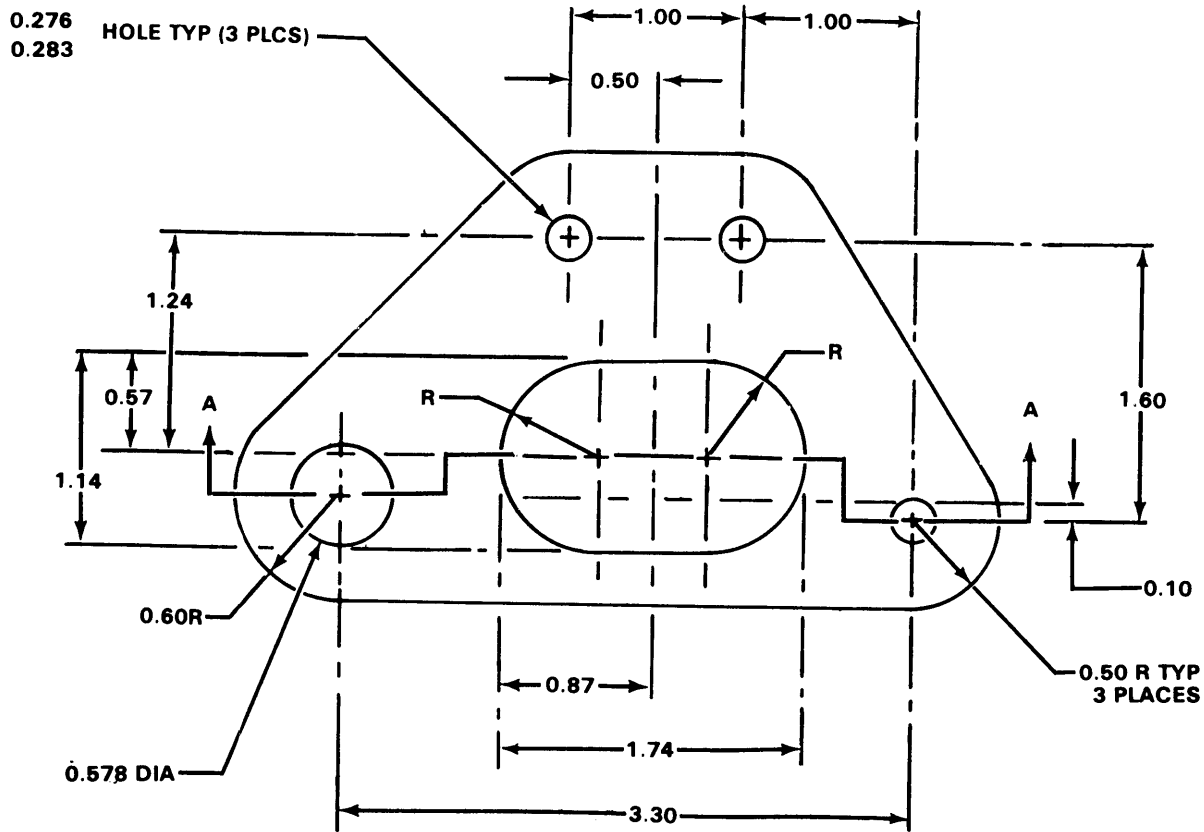
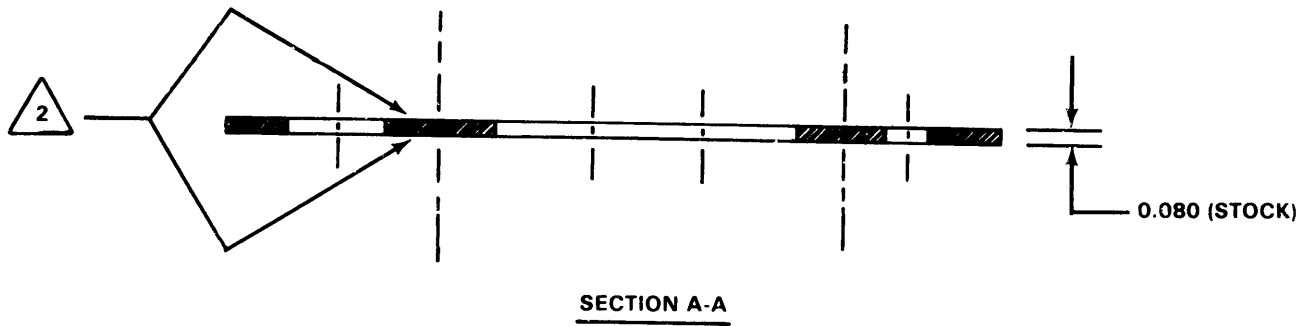
**NOTES:**

1. PART NO. 205-061-521-1 MAKE FROM BELL STD  
20-042-3 BULK STOCK EXTRUSION

2. EXTRUSION MAY BE PURCHASED FROM:  
COMPANY SOURCE DIE NO.

REYNOLDS ALUMINUM	32537
PIONEER ALUMINUM	PA16364
HOWMET CORPORATION	T-16657

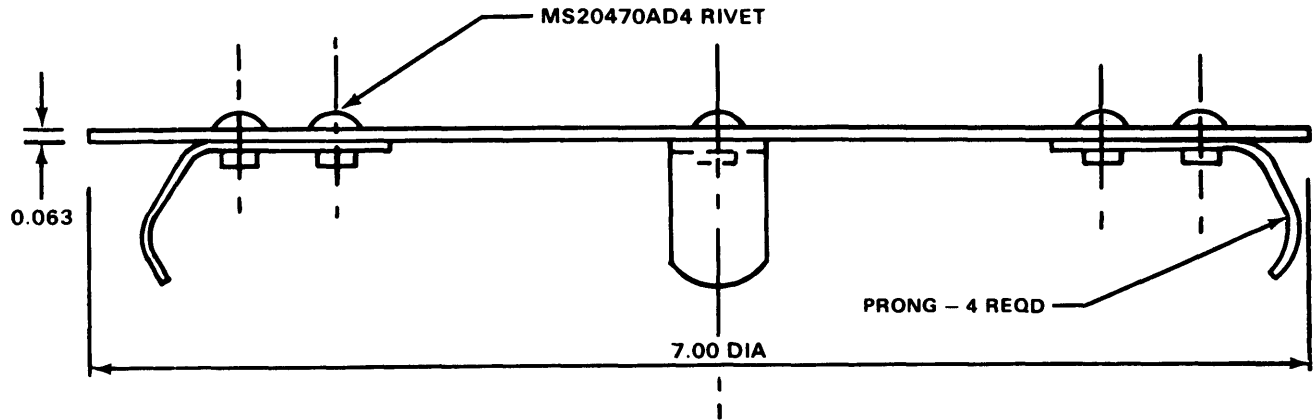
Figure D-332. Part Number 205-061-521-1 RADIUS BLOCK  
 Fabricate from: NSN 9636-00-232-0418  
 Material: 2024 AL ALY Federal Specification QQ-A-200/3, T4, or T3510 or T3511, 0.125 Inch Thick, 0.875 Inch Wide



**NOTES:**

**BOTH SURFACES SHALL BE FLAT WITHIN 0.005 TIR**

Figure D-333. Part Number: 205-061-643-3 PLATE  
 Fabricate from: NSN 9535-00-232-0398  
 Material: 2024 AL ALY, Federal Specification  
 QQ-A-250/5 T3, 0.080 Inch Thick,  
 3.1 Inch Wide, 4.9 Inch Long



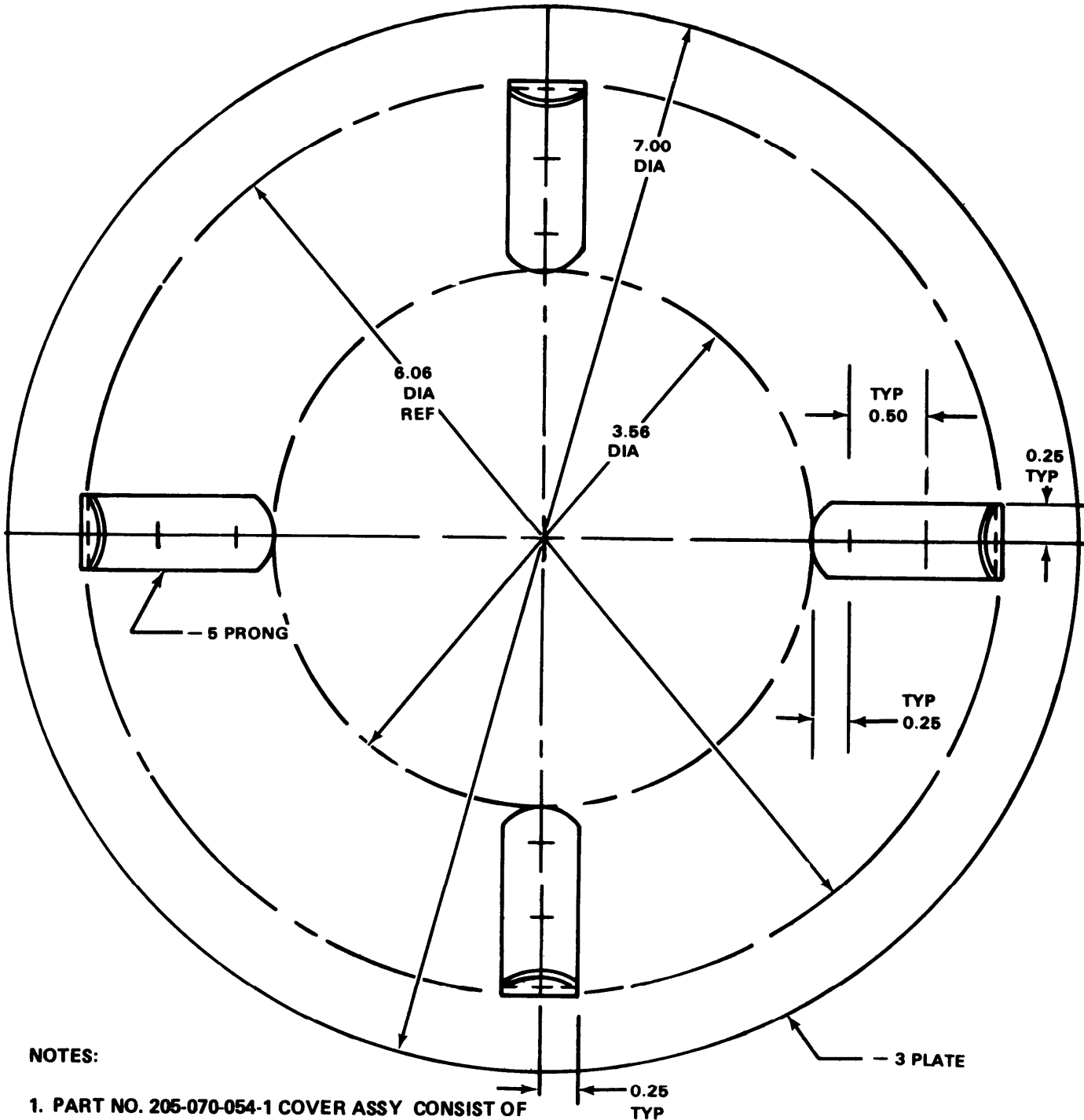
**NOTES:**

**ASSEMBLE 205-070-054-5 CLIP TO 205-070-054-3 PLATE**

Figure D-334. (Sheet 1 of 3) Part Number:  
Fabricate from:  
Material:

205-070-054-1 COVER ASSY  
NSN 9535-00-232-0378  
NSN 9515-00-184-8822  
2024 AL ALY, Federal Specification QQA-250/5,  
T3, 0.063 Inch Thick. Steel Corrosion Resistant  
18-8, Federal Specification MIL-S-5059 Comp 301,  
1/2 Hard, 0.025 Inch Thick

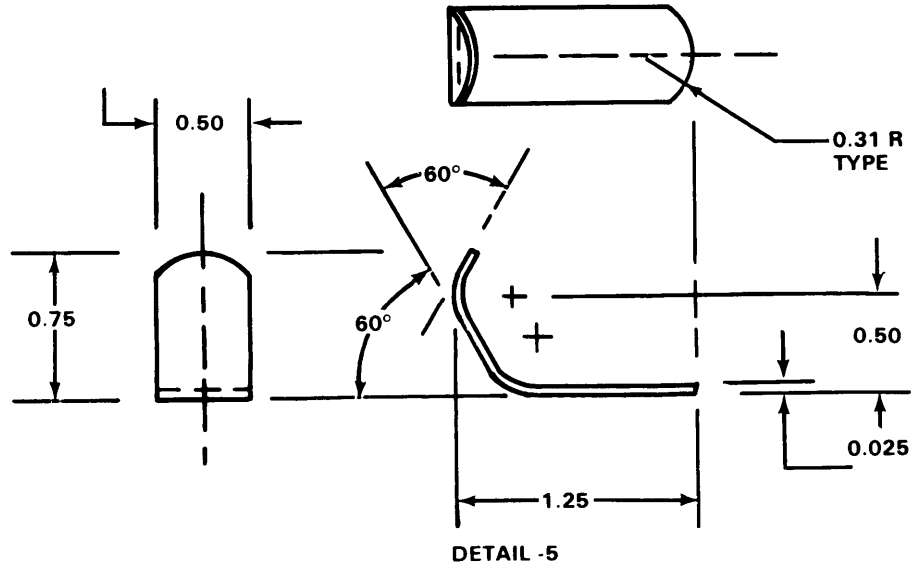




**NOTES:**

1. PART NO. 205-070-054-1 COVER ASSY CONSIST OF 205-070-054-3 PLATE AND 205-70-054-5 PRONG
2. 205-070-054-3 PLATE MAKE FROM 2025 AL ALY FEDERAL SPECIFICATION QQ-A-250/5 T3, 0.063 INCH THICK, 7.5 INCH WIDE, 7.5 INCH LONG (NSN 9535-00-232-0478)
3. BREAK ALL SHARP EDGES AND MARK PER BPS FW 4050

Figure D-334. (Sheet 2 of 3)



BEND RADII -.25  
BEND ANGLE TOL. ± 5°

NOTES:

1. PART NO. 205-070-054-5 PRONG MAKE FROM STEEL, CORROSION RESISTANT 18-8, FEDERAL SPECIFICATION MIL-S-5959 COMP 301, ½ HARD (NSN 9515-00-184-8822, 0.025 INCH THICK, 1.0 INCH WIDE, 2.3 INCH LONG
2. BREAK ALL SHARP EDGES

Figure D-334. (Sheet 3 of 3)

NOTES:

1. PART NO. 205-072-038-1 INSTRUMENT PANEL ASSY CONSIST OF THESE PARTS.

PART NO.	DESCRIPTION	SHEET
205-072-038-3	SIDE	2
205-072-038-5	END	3
205-072-038-7	END	4
205-072-038-9	PANEL	5
205-072-038-11	HINGE HALF	6
205-072-038-13	HINGE PIN	6

2. ASSEMBLE PARTS TO MAKE THE COMPLETE UNIT.

Figure D-335. (Sheet 1 of 7)

Part Number: 205-072-038-1 INSTRUMENT PANEL ASSY

Fabricate from: See Part Number Sheets  
Material: See Part Number Sheets

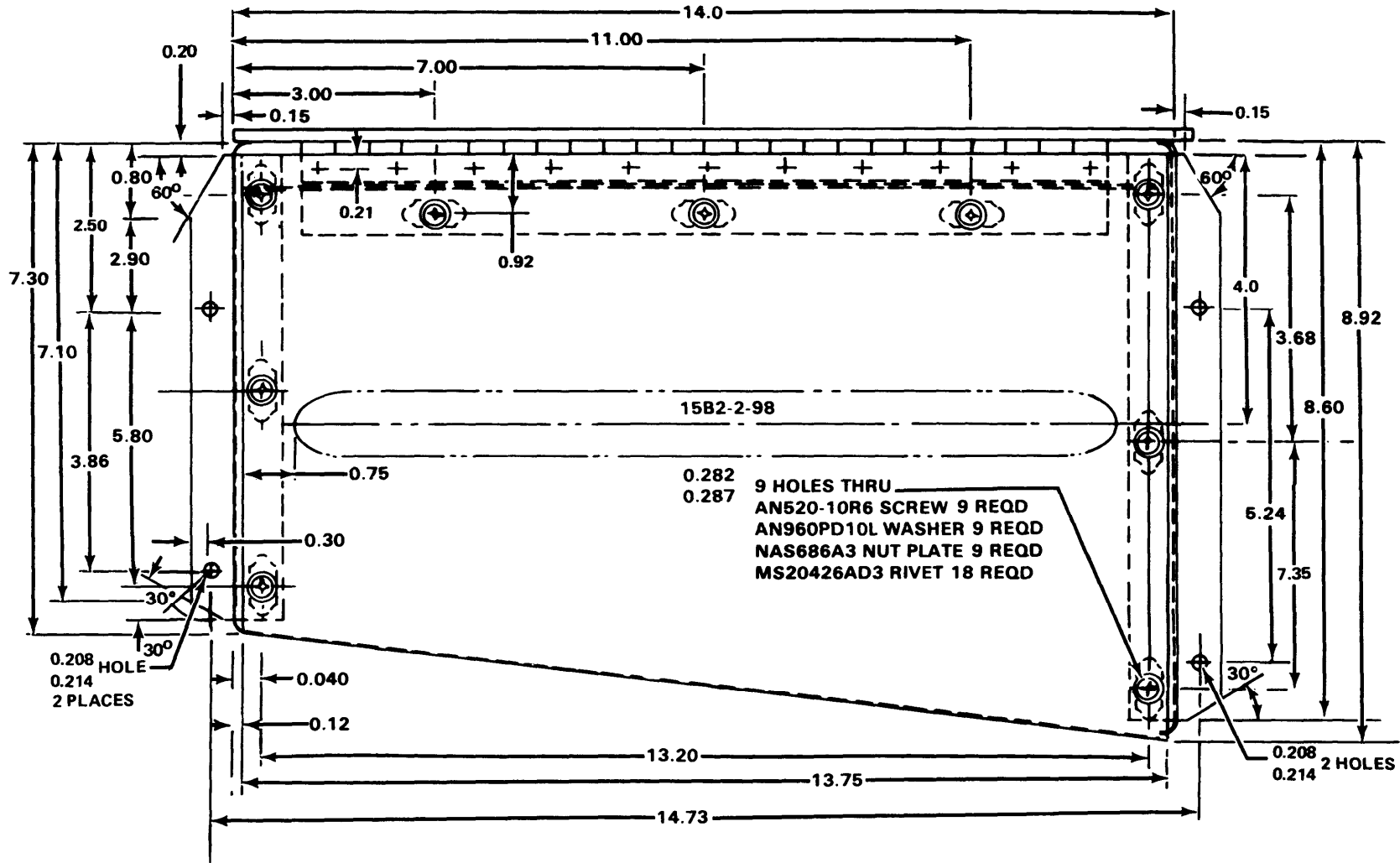


Figure D-335. (Sheet 2 of 7)

Part Number: 205-072-038-3 SIDE  
 Fabricate from: NSN 9535-00-086-9729  
 Material: 2024 AL ALY Federal Specification QQ-A-250/4 T3  
 0.032 Inch Thick, 9.7 Inch Wide, 14.3 Inch Long

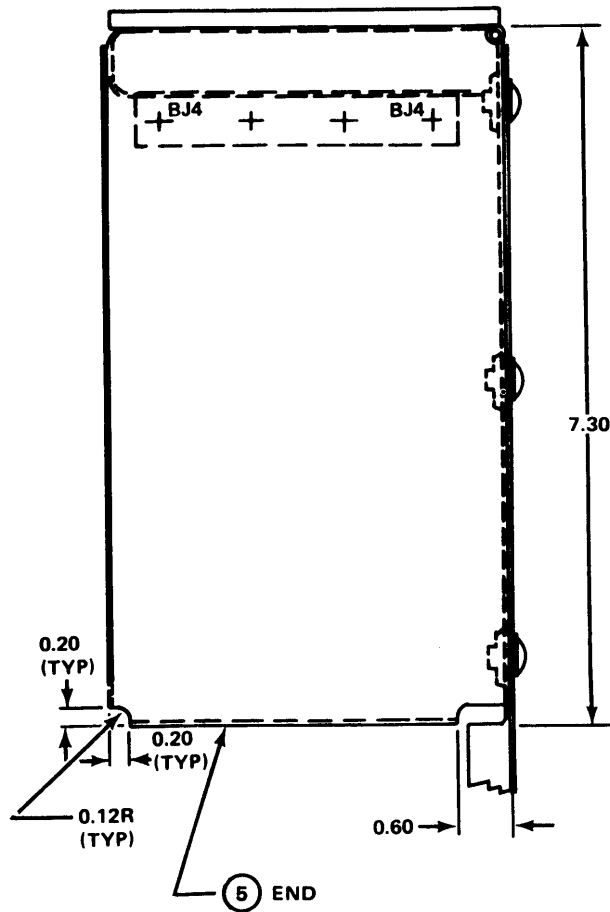


Figure D-335. (Sheet 3 of 7) Part Number 206-072-038-5 END  
 Fabricate from: NSN 9535-00-086-9729  
 Material: 2024 AL ALY Federal Specification QQ-A-250/4 T3,  
 0.032 Inch Thick, 6.1 Inch Wide, 8.2 Inch Long

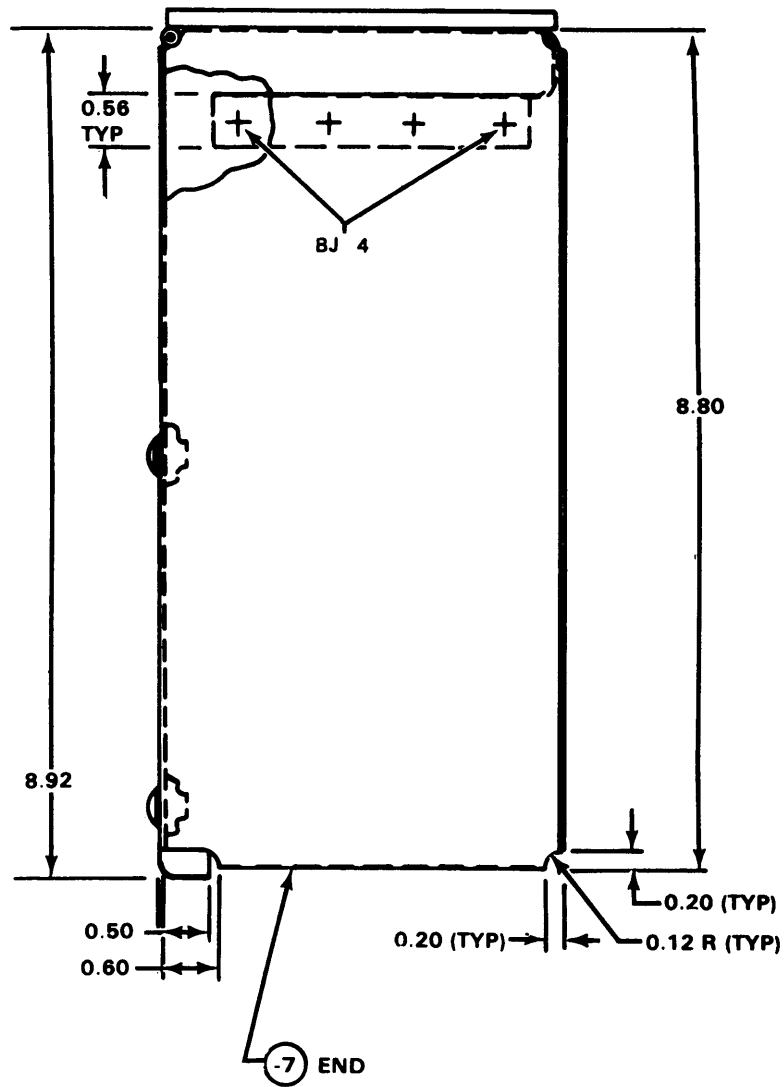


Figure D-335. (Sheet 4 of 7) Part Number:  
Fabricate from:  
Material:

205-072-038-7 END  
NSN 9535-00-086-9729  
2024 AL ALY, Federal Specification QQ-A-250/4 13,  
0.032 Inch Thick, 6.1 Inch Wide, 10.0 Inch Long

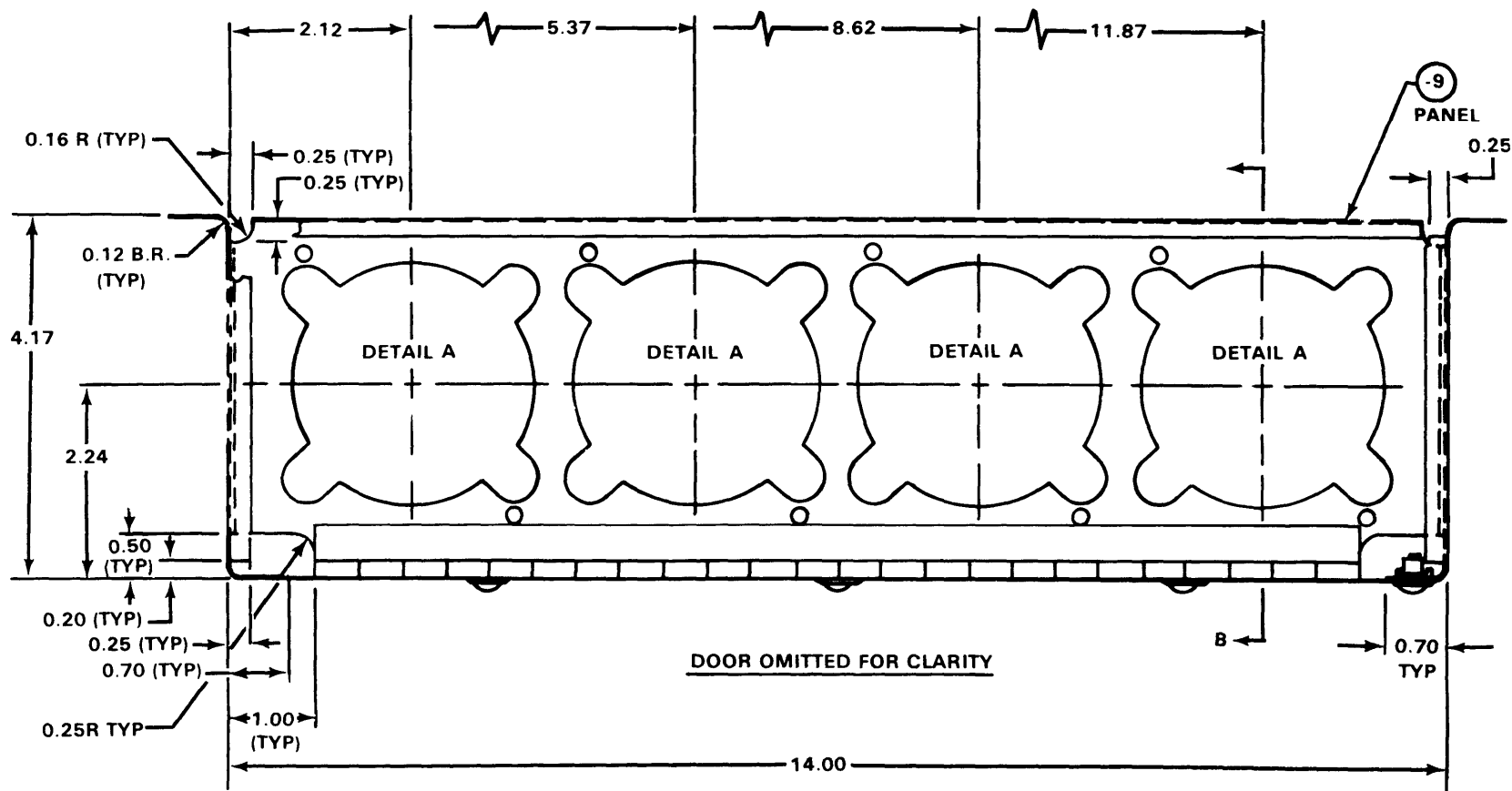
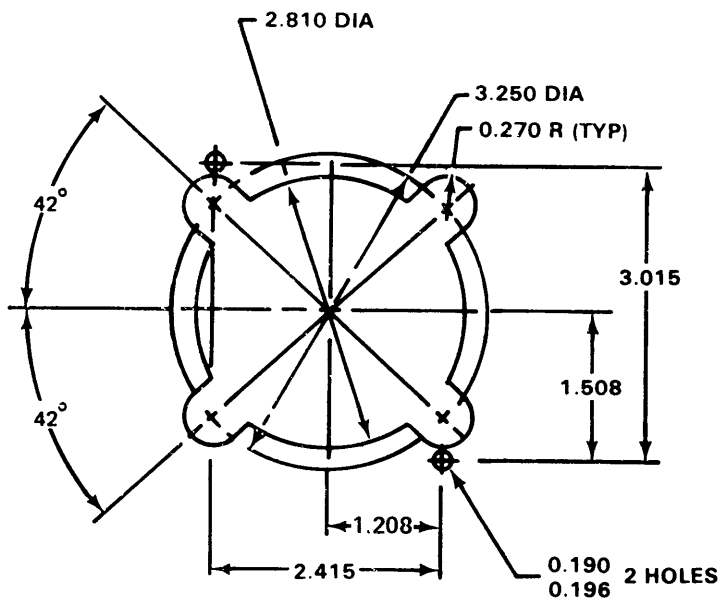
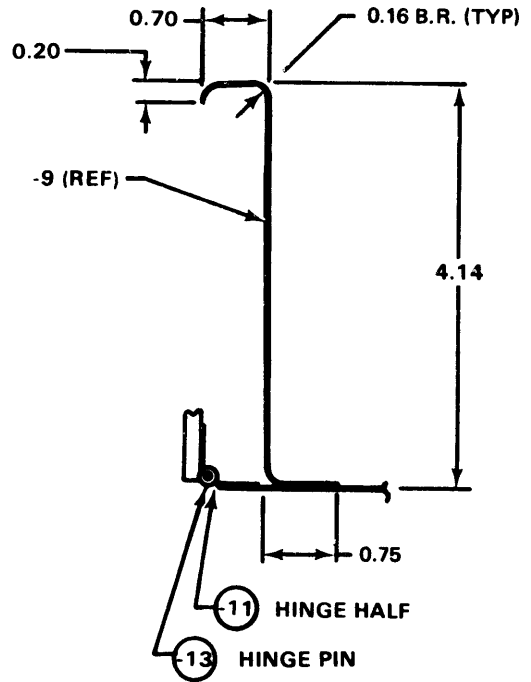


Figure D-335. (Sheet 5 of 7) Part Number:  
Fabricate from:  
Material:

205-072-038-9 PANEL  
NSN 9535-00-086-9930  
2024 AL ALY Federal Specification QQ-A-250/4 T3,  
0.040 Inch Thick, 7.0 Inch Wide, 16.0 Inch Long



DETAIL A



SECTION B-B

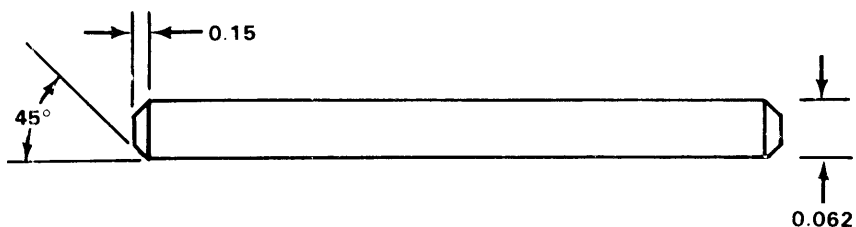
NOTES:

1. CUT HOLES IN -9 PANEL PER DETAIL A AND SECTION B

Figure D-335. (Sheet 6 of 7)

Part Number

206-072 -038-9 PANEL



**NOTES:**

1. 205-072-038-13 HINGE PIN MAKE FROM MS20253P1-7200 MATERIAL

Part Number	205-072-038-13 HINGE PIN
Fabricate from:	NSN 5340-00-182-9901
Material:	Rod Straight, Headless, Corrosion Resistant Cadmium Plated 0.062 Dia., 11.88 Inch Long

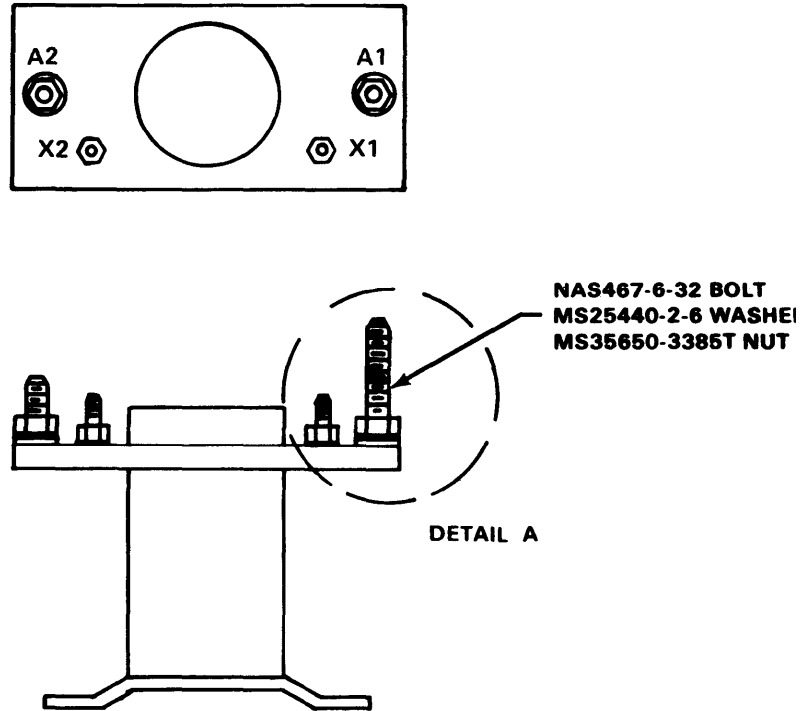


**NOTES:**

1. 205-072-018-11 HINGE HALF MAKE FROM MS20257HP2-7200 STOCK MATERIAL

Figure D-335. (Sheet 7 of 7)	Part Number	206-072-038-11 HINGE HALF
	Fabricate from:	NSN 5340-00-993-1461
	Material:	Leaf Butt Hinge AL ALY Anodized 0.531 Inch Wide, 0.040 Inch Thick, 12.00 Inch Long

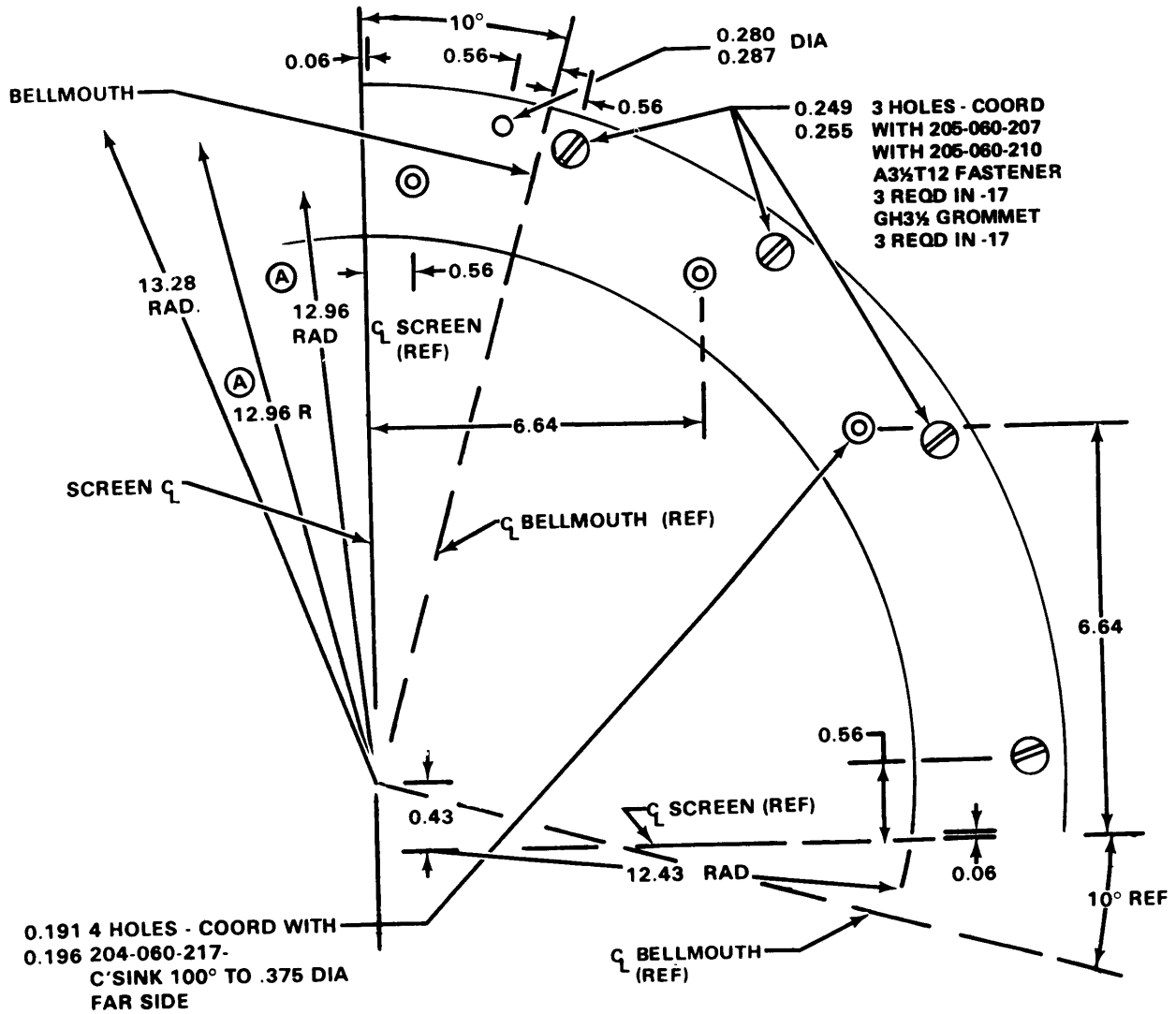




**NOTES:**

1. ALTER MS 24171-D1 RELAY PER DETAIL A  
REMOVE EXISTING STUD AT POSITION A1  
AND INSTALL NAS 467-6-32 BOLT
2. 205-075-137-3 RELAY MAKE USING  
ALTERED MS 24171-D1 RELAY SOLENOID

Figure D-336.	Part Number:	205-075-137-3 RELAY
	Fabricate from:	NSN 5306-00-819-5120
		NSN 5945-00-660-931 5
	Material:	Machine Bolt (NAS 467-6-32)
		Relay Solenoid (MS 24171-D1)

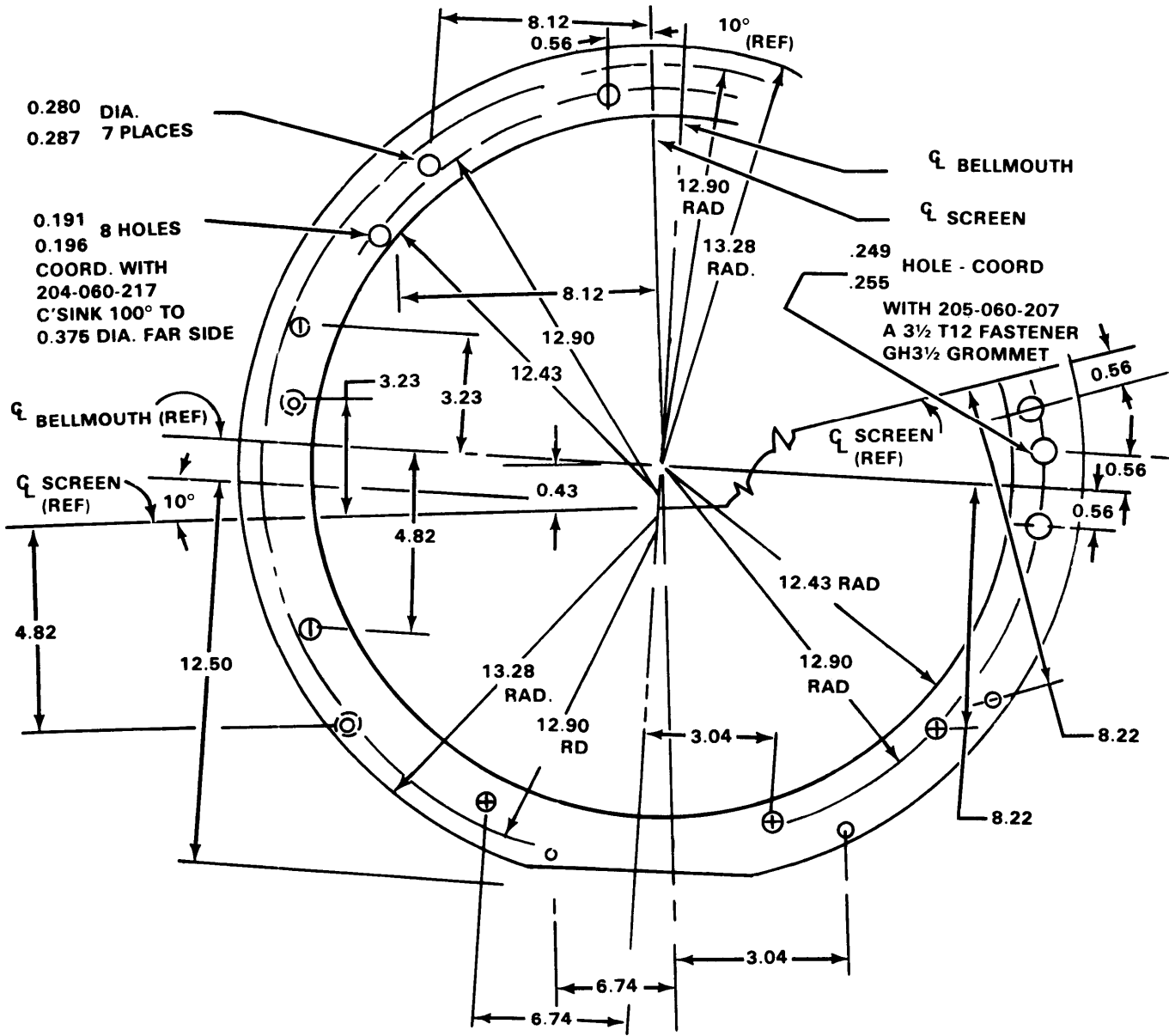


NOTES:

2024 AL ALY FEDERAL SPECIFICATION QQ-A-362  
 T3, 0.090 INCH THICK MATERIAL MAY BE USED  
 AS AN ALTERNATE

Figure D-337. Part Number:  
 Fabricate from:  
 Material:

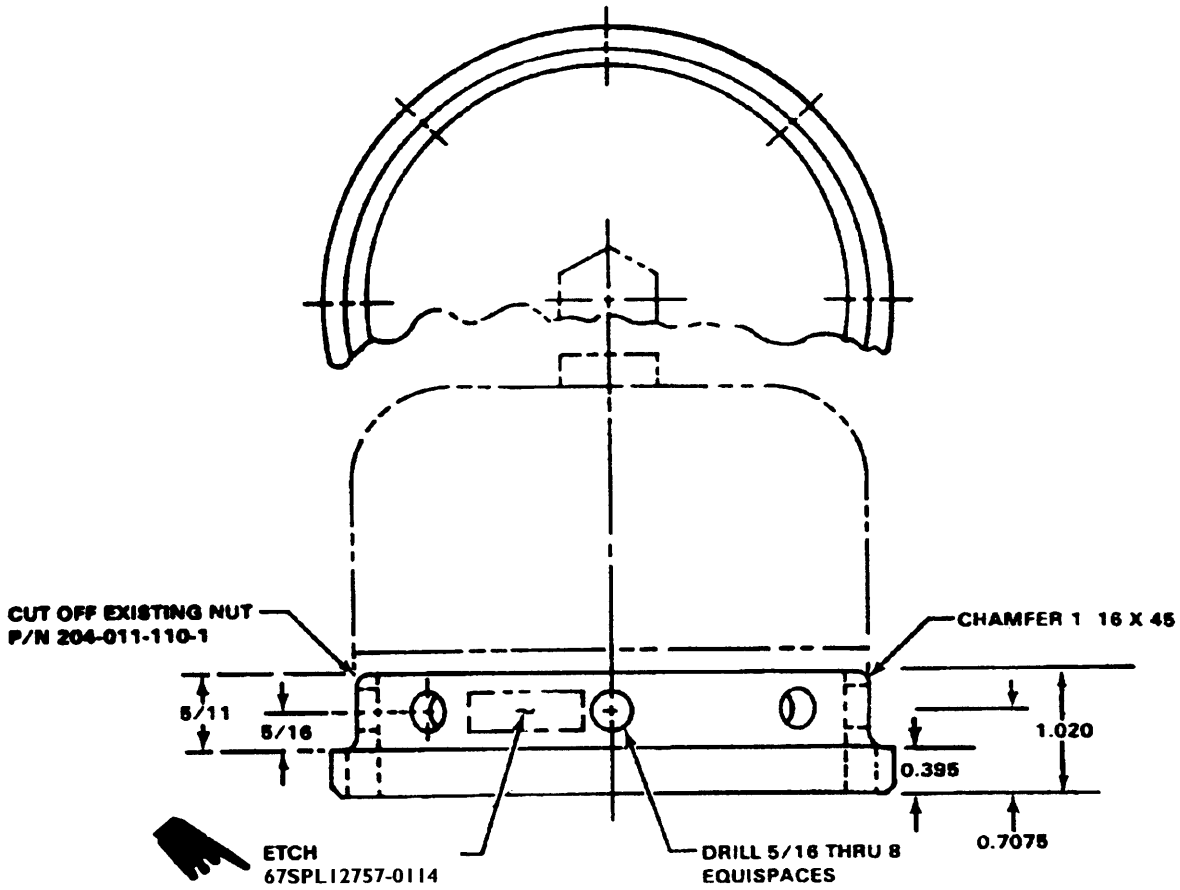
205-706-025-17 ADAPTER SEGMENT  
 NSN 9535-00--232-0405  
 2024 AL ALY, Federal Specification, QQ-A-362, T3, 0.093  
 Inch Thick, 13.7 Inch Wide, 14.0 Inch Long



NOTES:

2024 AL ALY FEDERAL SPECIFICATION QQ-A-362  
T3, 0.090 INCH THICK MATERIAL MAY BE USED AS  
AN ALTERNATE

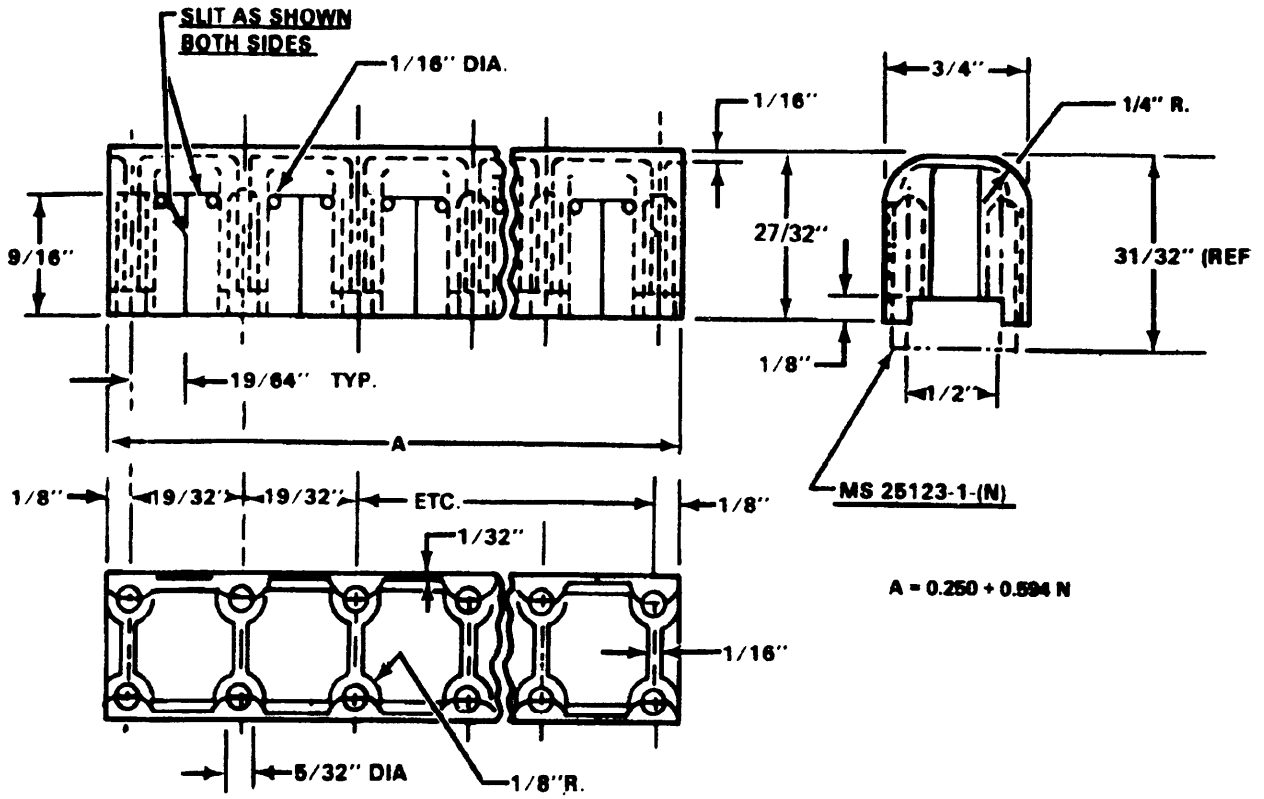
Figure D-338. Part Number 205-706-025-19 ADAPTER SEGMENT  
Fabricate from: NSN 9535-00-232-0405  
Material: 2024 AL ALY Federal Specification QQ-A-362 T3,  
0.093 Inch Thick, 27.5 Inch Wide, 27.5 Inch Long



**NOTES:**

1. USE 204-011-116-1 NUT FOR REWORK INTO WRENCH ADAPTER.
2. REMOVE EXCESS MATERIAL AS INDICATED ABOVE, AND DRILL HOLES.
3. MARK NEW PART NO AS INDICATED ON FIGURE ABOVE.

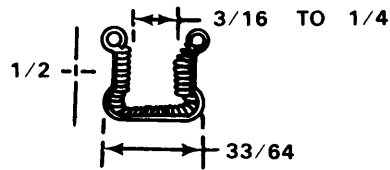
Figure D-339. Part Number 67SPL12757-0114 WRENCH ADAPTER  
 Fabricate from: NSN 1615-00-474-9840  
 Material:



**NOTES:**

1. COVER DESIGNED FOR USE ON MS 25123-1-(N) AN3436-1-(N), AN3436-2(N) TERMINAL BOARD
2. DESIGNATION (N) INDICATES THE NUMBER OF TERMINAL STUDS WILL COVER

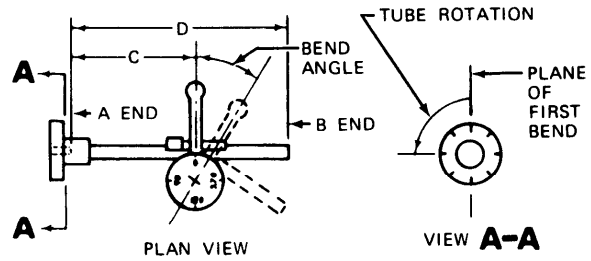
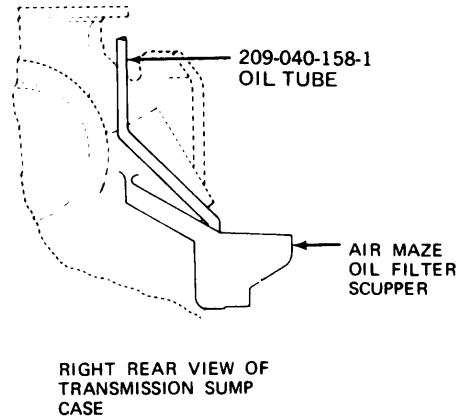
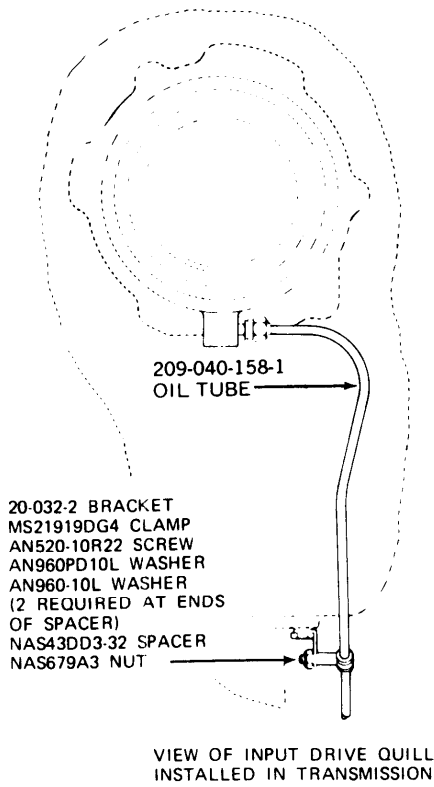
Figure D-340. Part Number 397-1 COVER ELECTRICAL TERMINAL BOARD  
 Fabricate from: NSN 5940-00-082-4642  
 Material: Plastic, phenol-formaldehyde



**NOTES:**

1. PART NO. 204-030-853-97, -98, -99, -100  
CHANNEL MAKE FROM COMMERCIAL  
PART Y563-2 CHANNEL EACH PART  
NO ALL 127.0 INCH LONG
2. PURCHASE CHANNEL FROM  
STANDARDS PRODUCTS CO.  
2130 WEST 10TH STREET  
CLEVELAND, OHIO  
CODE IDENT 82654

Figure D-341. Part Number: 204-030-853-97 CHANNEL  
 204-030-853-98 CHANNEL  
 204-030-853-99 CHANNEL  
 204-030-853-100 CHANNEL  
 Fabricate from: NSN 1560-00-004-4458  
 Material: Channel Rigid Pile Lining Uncovered, 33/64 Inch Wide,  
 1/2 Inch High 3/16 to 1/4 Opening



Part Number 209-040-158-1 Oil Tube  
Fabricate From NSN 4710-00-541-4932  
Material Aluminum Alloy Tube

INSTALLATION INSTRUCTIONS

FINISHED TUBE DIMENSIONS							
BEND NO.	C INCHES	BEND RADIUS INCHES	TUBE ROTATION FROM PLANE OF FIRST BEND, CCW VIEWED FROM B END, DEGREES.	BEND ANGLE DEGREES	D = 17.25 ALONG C OF TUBE FROM END A TO B		
1.	15.94	0.56	0	90	END	FITTING	4
2.	12.00	0.56	274	46	A	NONE	
3.	9.62	0.56	197	30			
4.	8.12	0.56	14	29	B	AN818-4D	2
5.	5.50	0.56	93	51		MS20819-4D	
6.	2.69	0.56	213	38	TYPE OF END		
FABRICATION INSTRUCTIONS							
STOCK TUBE SIZE			MATL	MATL SPEC		1	FLARE . . . . . MS33584
OD	WALL	LENGTH	5052-0 AL. ALY. TUBE	WW-T-700/4	TYPE 1 TEMP - 0	2	DBL FLARE . . . . . MS33583
1/4	0.028	19.0				3	BEAD . . . . . MS33660
						4	SQUARE
						5	NOTED

Part Number AN8 18-4D, Nut, Tube Coupling  
NSN 4730-00-287-0289

Part Number MS208 19-4D, Sleeve, Flares, Tube  
NSN 4730-00-302-8641 Figure D-342.

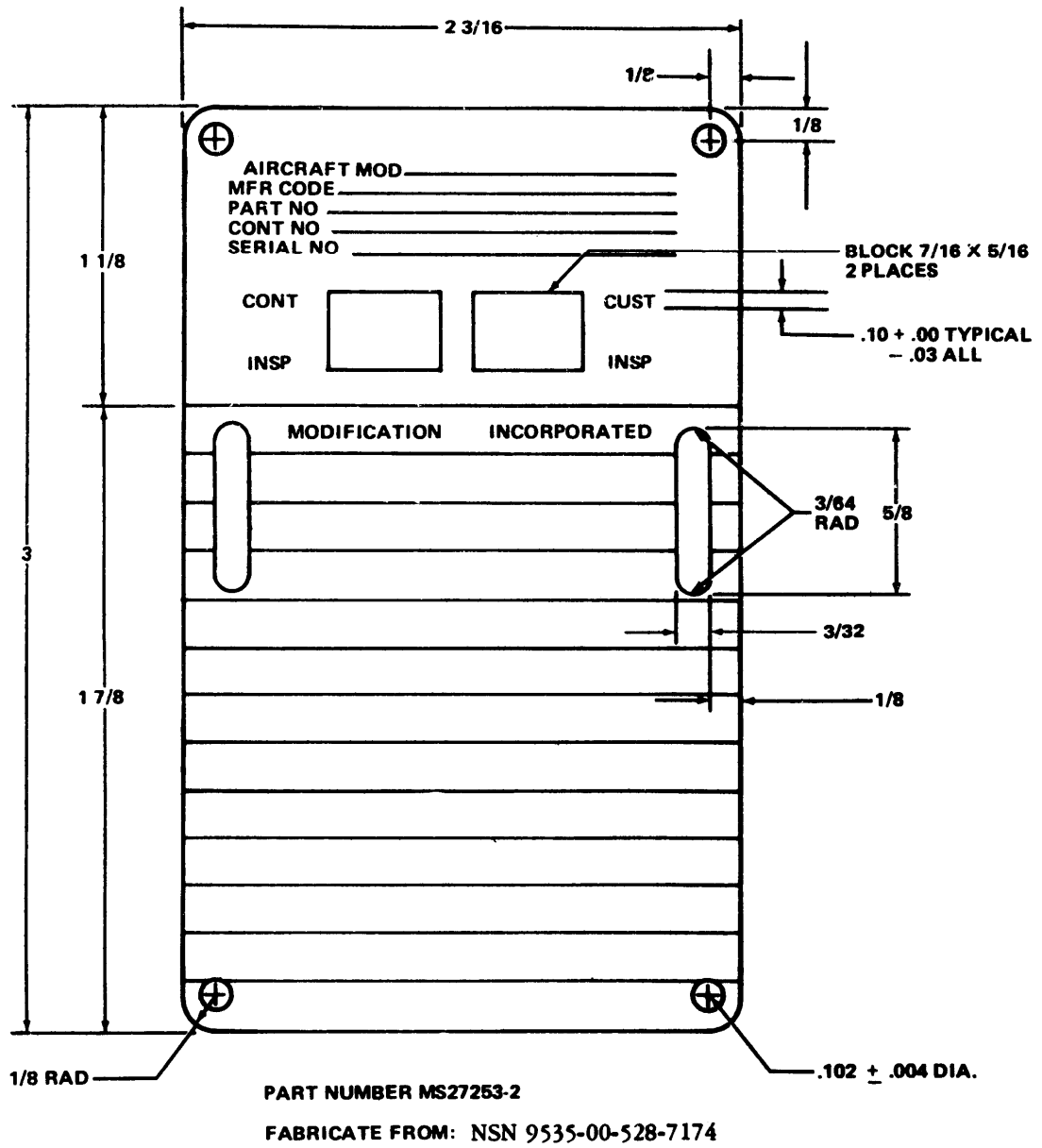
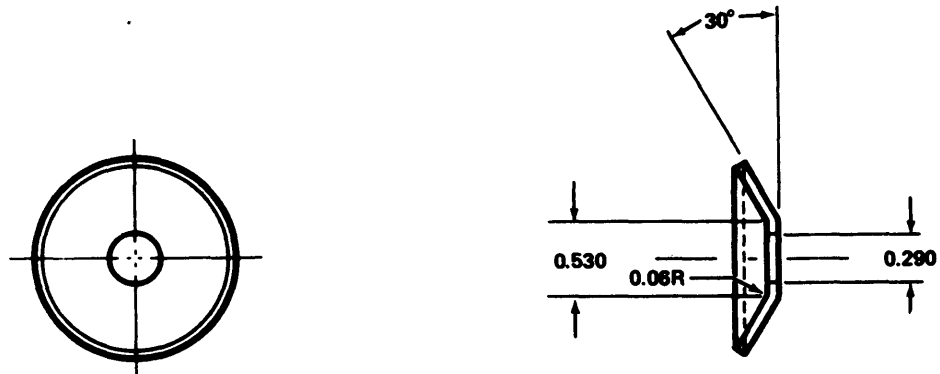


Figure D-343, Plate , Modification



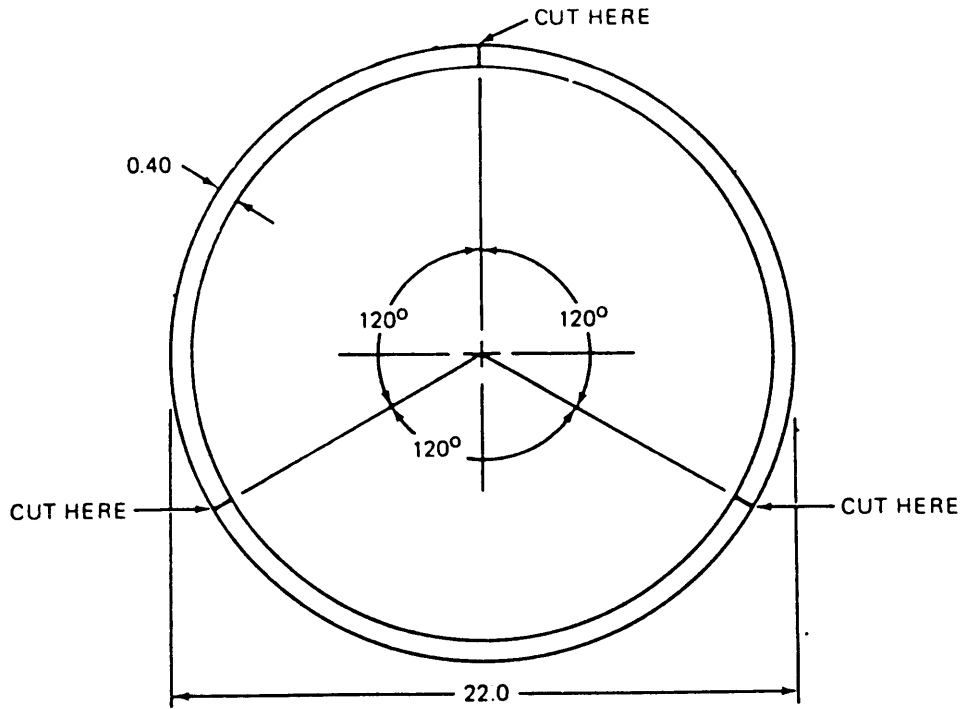


**NOTES:**

1. Brush CAD reworked areas as required.

**WASHER, SAFETY**  
**PART NUMBER: 206-010-324-1 (FSCM 97499)**  
**FABRICATE FROM: NSN 5310-00-167-0766**

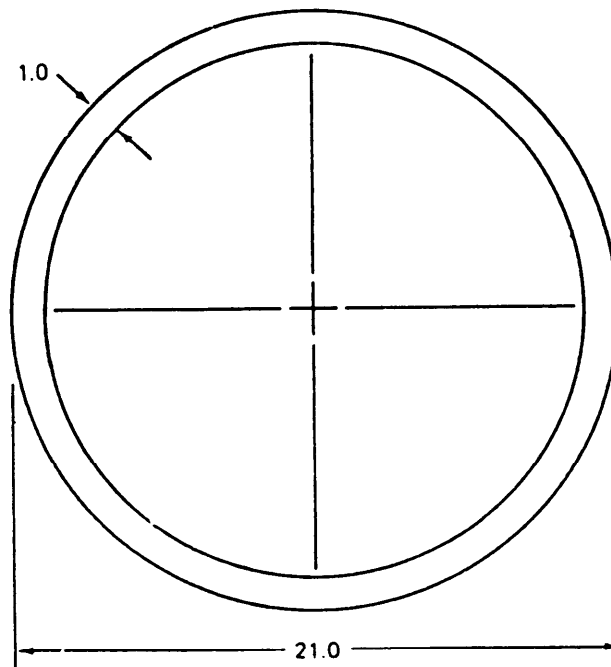
Figure D-344. Washer, Safety



NOTE  
EACH SECTION CONSTITUTES  
A 204-060-868-5 GASKET. THREE  
GASKETS ARE REQUIRED FOR  
INSTALLATION.

GASKET  
PART NUMBER: 204-060-868-5  
FABRICATE FROM: 5330-00-938-1719

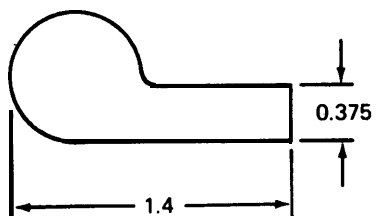
Figure D-345. Gasket



GASKET  
PART NUMBER: 204-060-816-33  
FABRICATE FROM: 5330-00-938-171

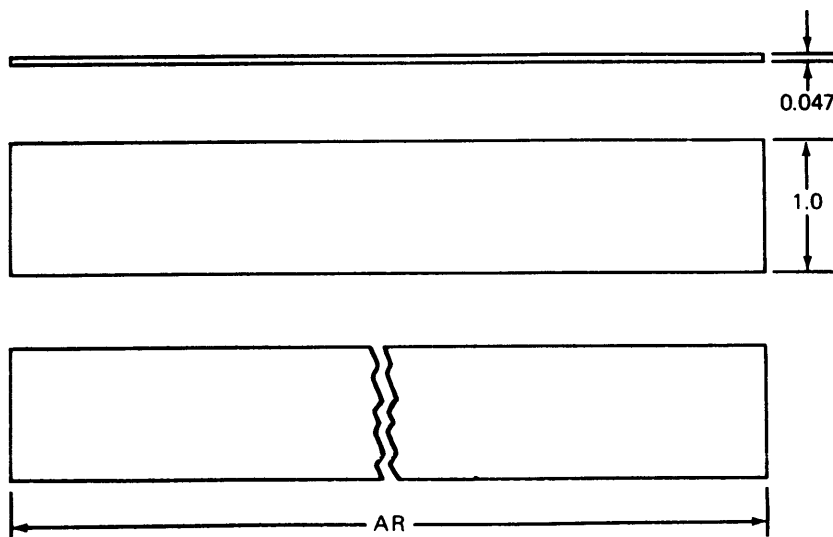
Figure D-346. Gasket





**PART NUMBER: 205-060-909-7**  
**FABRICATE FROM: NSN 9390-00-851-9178**  
**LENGTH: AS REQUIRED**

Figure D-347. Seal, Tadpole



**PART NUMBER: 205-060-909-23**  
**FABRICATE FROM: NSN 5330-00-938-1719**

Figure D-348. Gasket

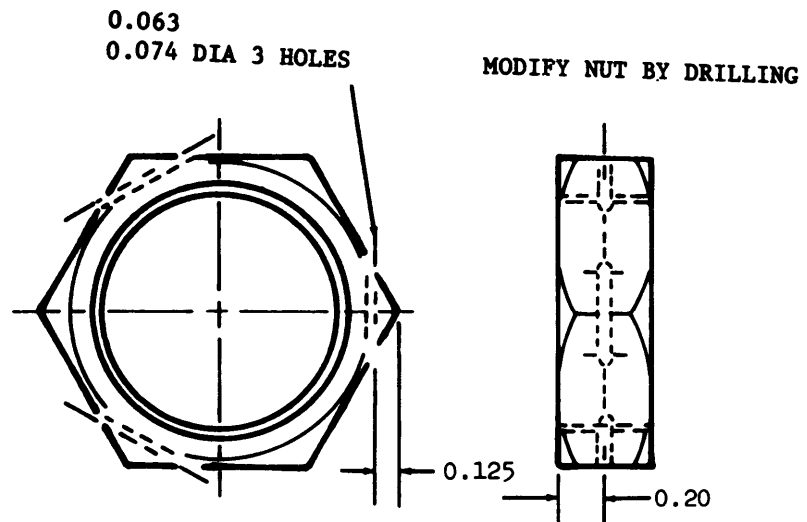
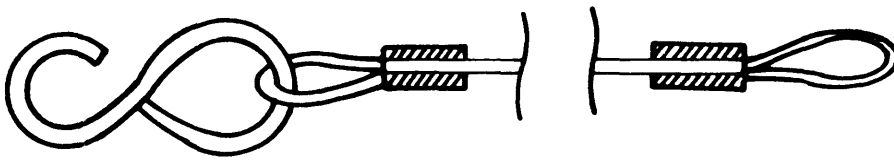


Figure D-349. Engine torque transmitter nut  
PART NUMBER 270-580292-12  
FABRICATE FROM: NSN 5310001991028  
MATERIAL: AN924-12D



NOTE: Overall length of cable assy  
to be determined at time of installation.

Figure D-350. Part Number 1560-UH1-76C Cable Assembly, Cargo Door  
Fabricate from: NSN 4010-00-222-4482 Cable 1/16inch  
NSN 9505-00-528-5017, Rod 3/16 inch  
4181 steel  
NSN4030-00-452-2568 Swaging sleeve (2)

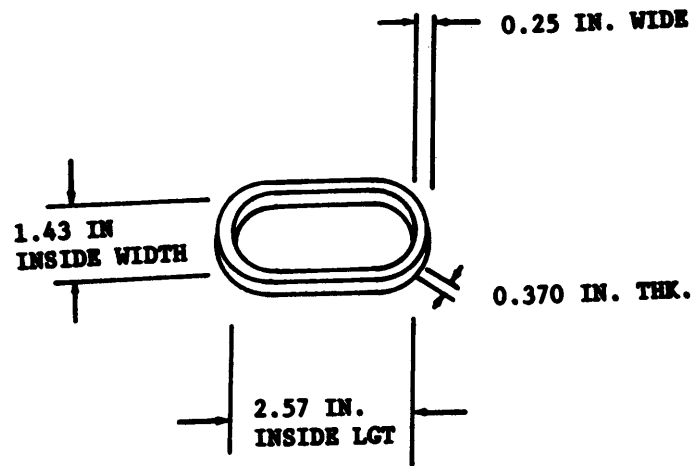
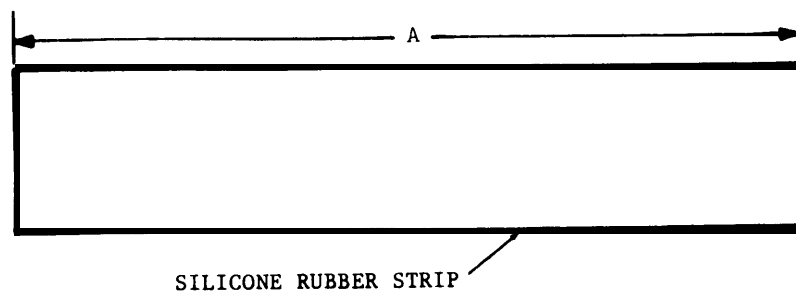


Figure D-351 Part Number AA 8621-2D12 Gasket  
Fabricate from: NSN 9320-00-839-8503  
Material: Rubber Sheet Cellular,  
MIL-R-6130, Type 2, Grade A,  
condition soft



PART NUMBER	NOMENCLATURE	FABRICATE FROM NSN	A
204-030-287-89	SILICONE RUBBER STRIP	9320-00-827-0584	26 INCHES
204-030-287-91	SILICONE RUBBER STRIP	9320-00-827-0584	2.5 INCHES
204-031-347-25	SILICONE RUBBER STRIP	9320-00-827-0584	24 INCHES
205-031-669-105	RUBBER SEAL	9320-00-113-5845	100 INCHES
205-060-805-13	RUBBER SEAL	9390-00-138-4145	17 INCHES
205-030-028-29	SILICONE RUBBER STRIP	9320-00-827-0584	32.5 INCHES
205-030-484-25	SILICONE RUBBER STRIP	9320-00-827-0584	32.5 INCHES

Figure D-352,

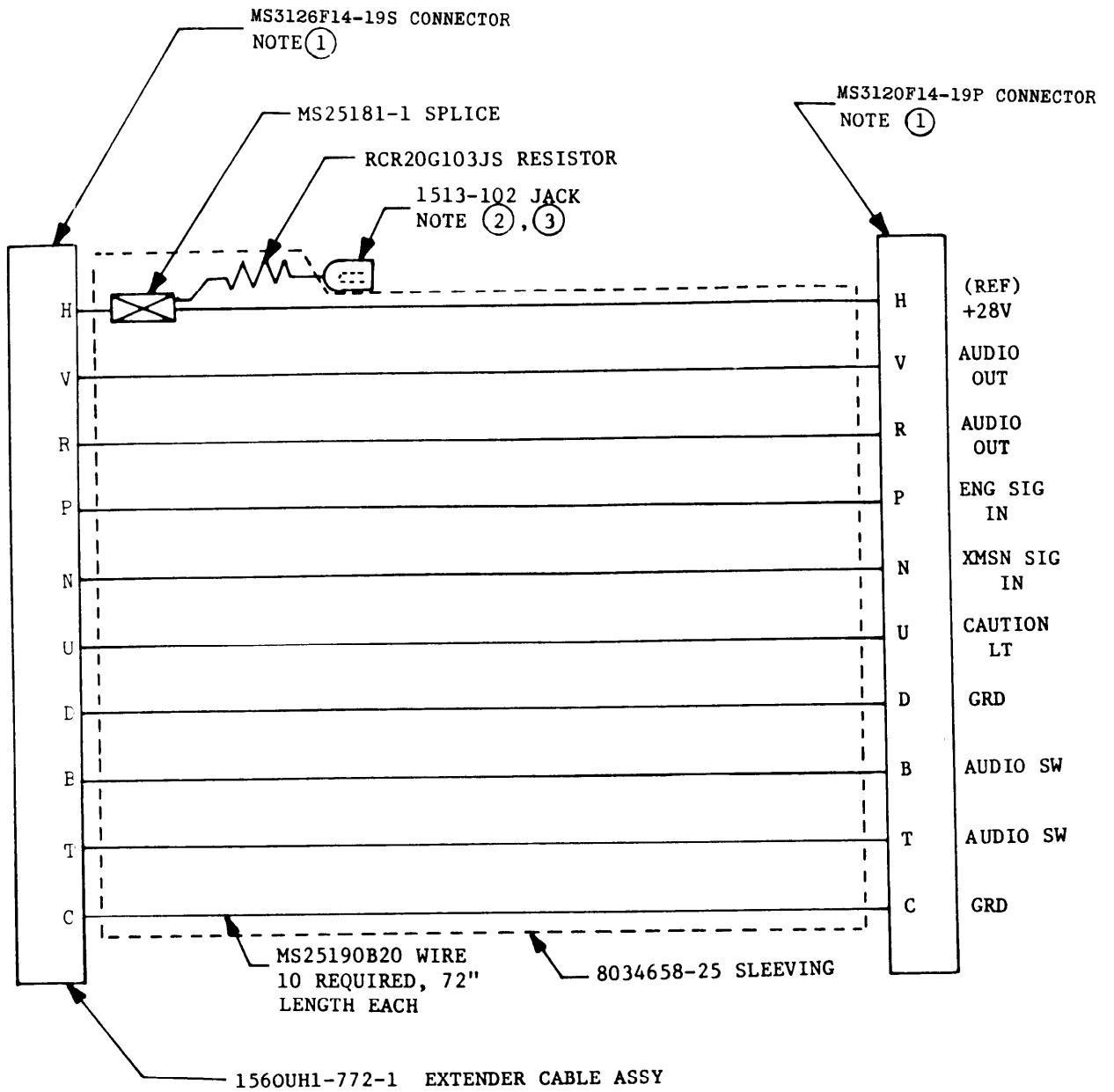
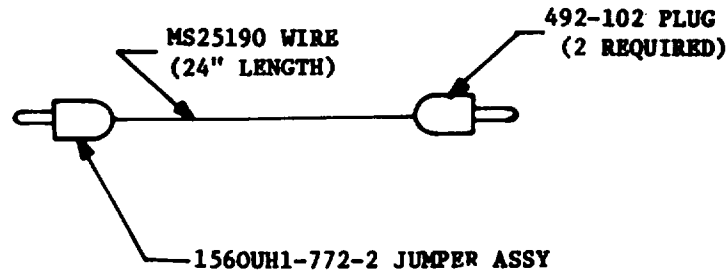


Figure D-353.(Sheet 1 of 2)





NOTES

- 1 PIN A, E, F, G, J, K, L, M, S NOT USED
- 2 MARK "AUX JACK"
- 3 UNINSULATED LEAD MUST BE COVERED BY SLEEVING, SECURE JACK TO CABLE
- 4 INSULATED WITH STD PHONE TIP (0.080 DIA X 0.5 INCH TEST PROD)
- 5 INSULATED, CABLE MOUNT ACCEPTS STD PHONE TIP (NOTE 4)

Figure D-353 Part Number 1560 UH1-772-1, RPM  
WARNING DETECTOR TEST EXTENDER CABLE  
ASSEMBLY (sheet 2 of 2)

- Fabricate from: NSN 6145-00-851-8505
- Material: MIL-W-50861 Type 2
- Material: NSN 5970-00-557-6254
- Material: MIL-J-7444, Type 1 Class 1
- Material: NSN 5935-00-078-3586
- Material: MIL-C-26482
- Material: NSN 5935-00-765-5989
- Material: MIL-C-26482
- Material: NSN 5935-00-909-7894
- Material: 5
- Material: NSN 5905-00-141-0591
- Material: MIL-R-39008
- Material: NSN 5940-01-007-7875
- Material: MIL-T-7928

- Part Number 1560UH1-772-2, RPM  
WARNING DETECTOR TEST JUMPER ASSEMBLY
- Fabricate from: NSN 6145-00-851-8505
- Material: MIL-W-5086 Type 2
- Material: NSN 5935-00-578-3494

(4)

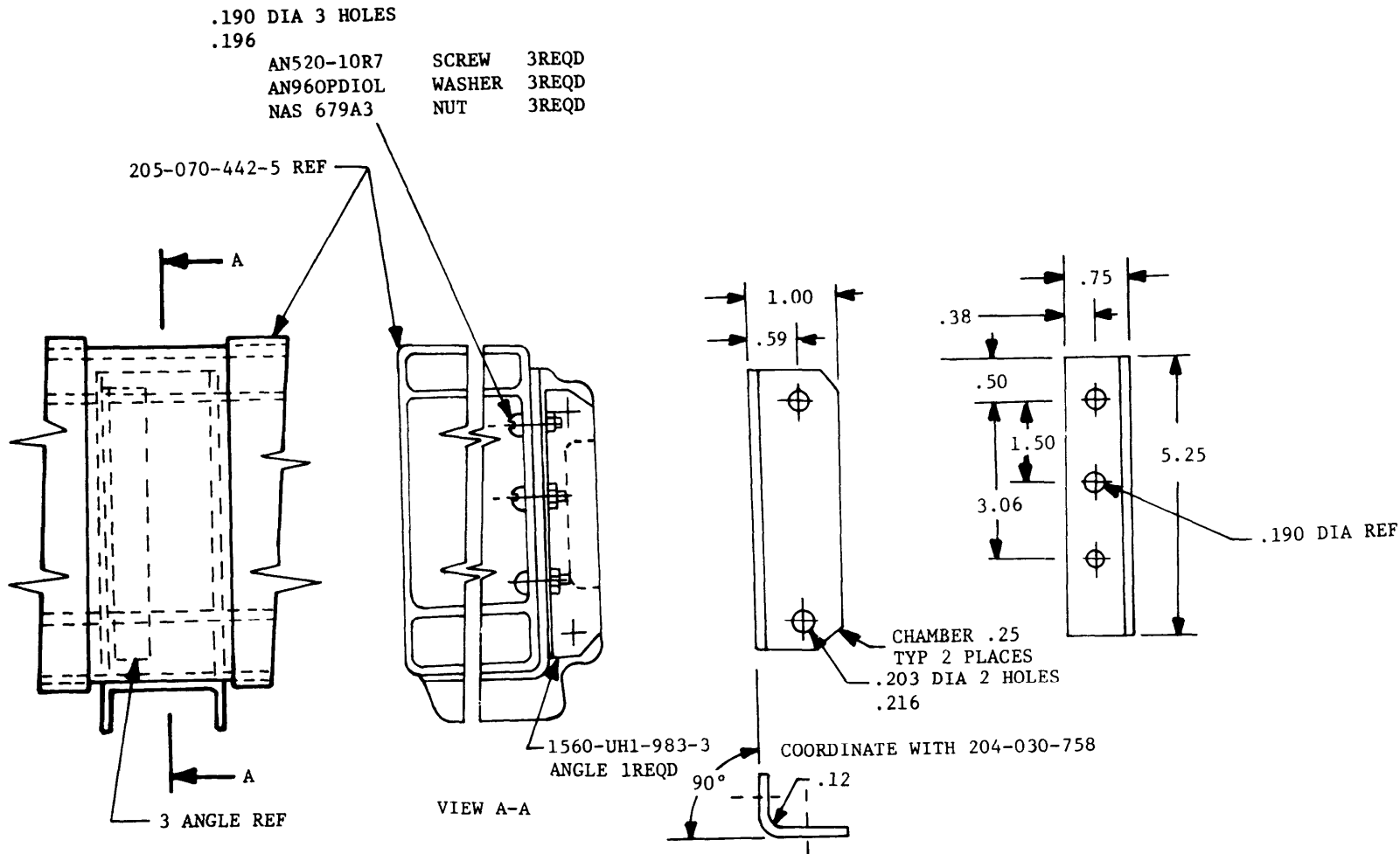


Figure D-354. Part Number 1560-UH1-983-3,  
Angle, Air Distribution Valve

Fabricate from: NSN 9535-00-086-9729  
Material: 2024-T3 QQ-A-250/5  
.032 X 1.75 X 5.25

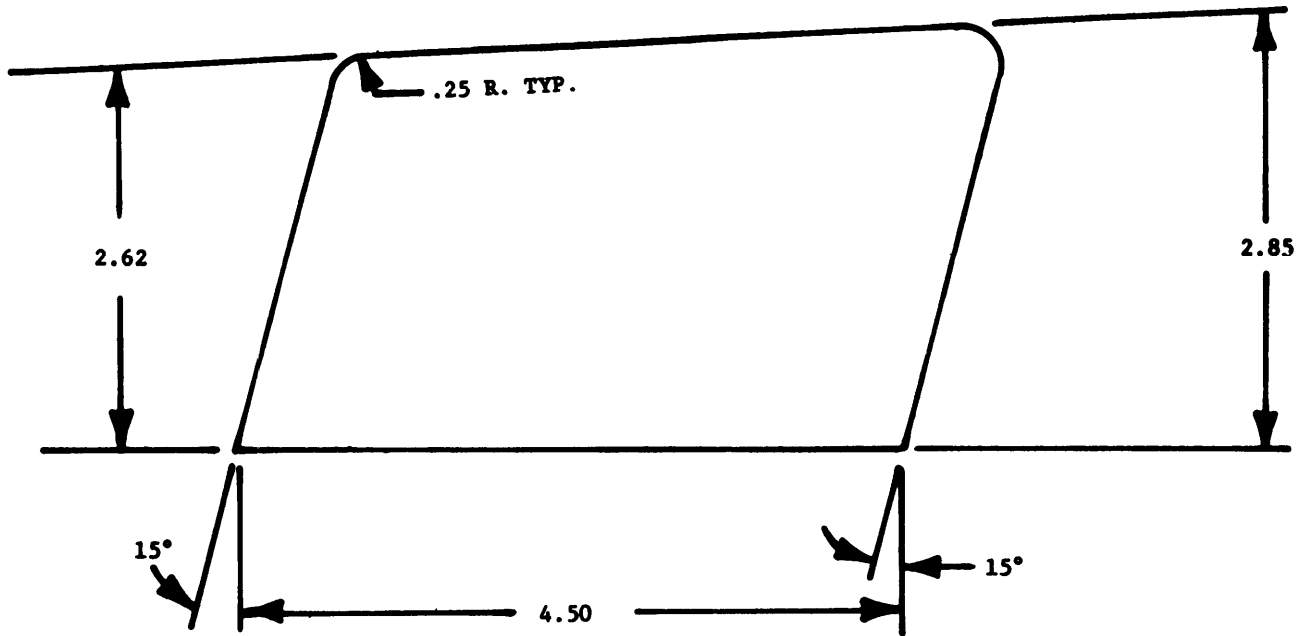


Figure D-355. Part Number 1560-UH1-781 Doubler Plate,  
R-1963/ARN  
Fabricate from: NSN 9535-00-232-8846  
Material: Aluminum Sheet, .032 inch  
thick 2024-T3, QQ-A-250/4

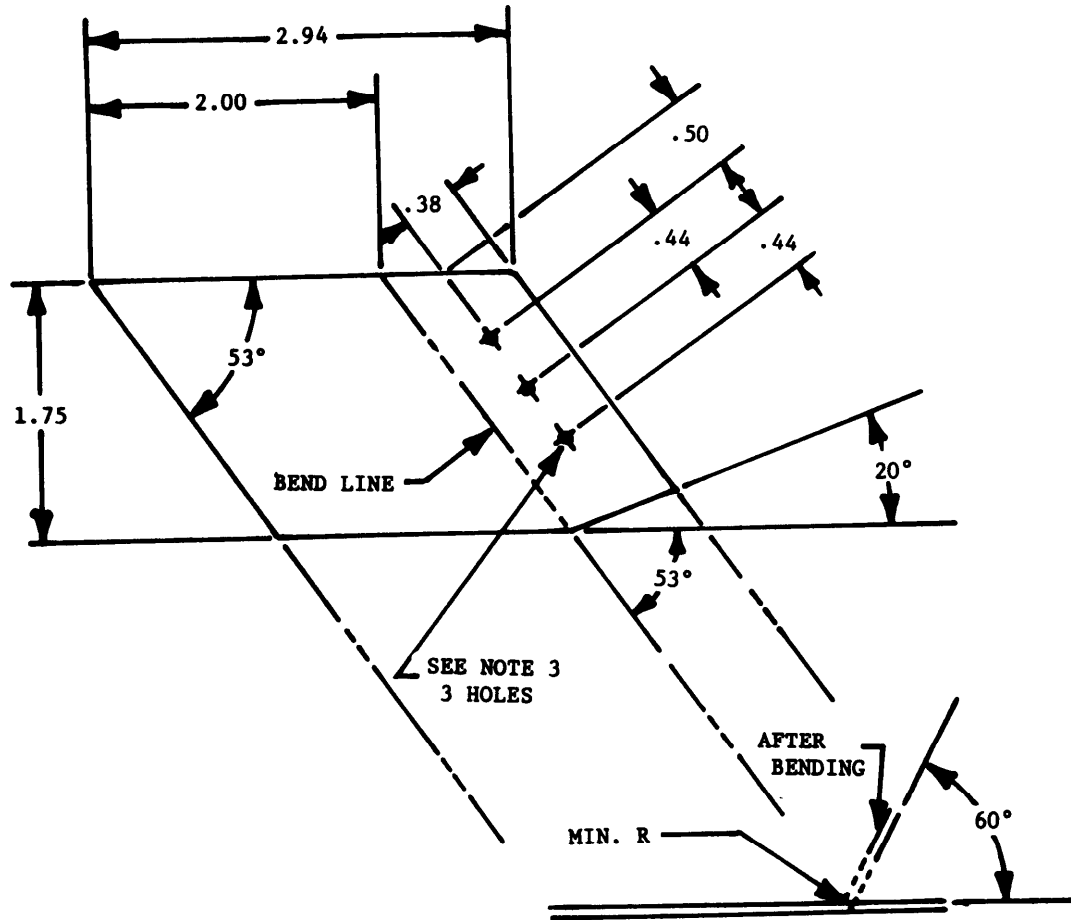
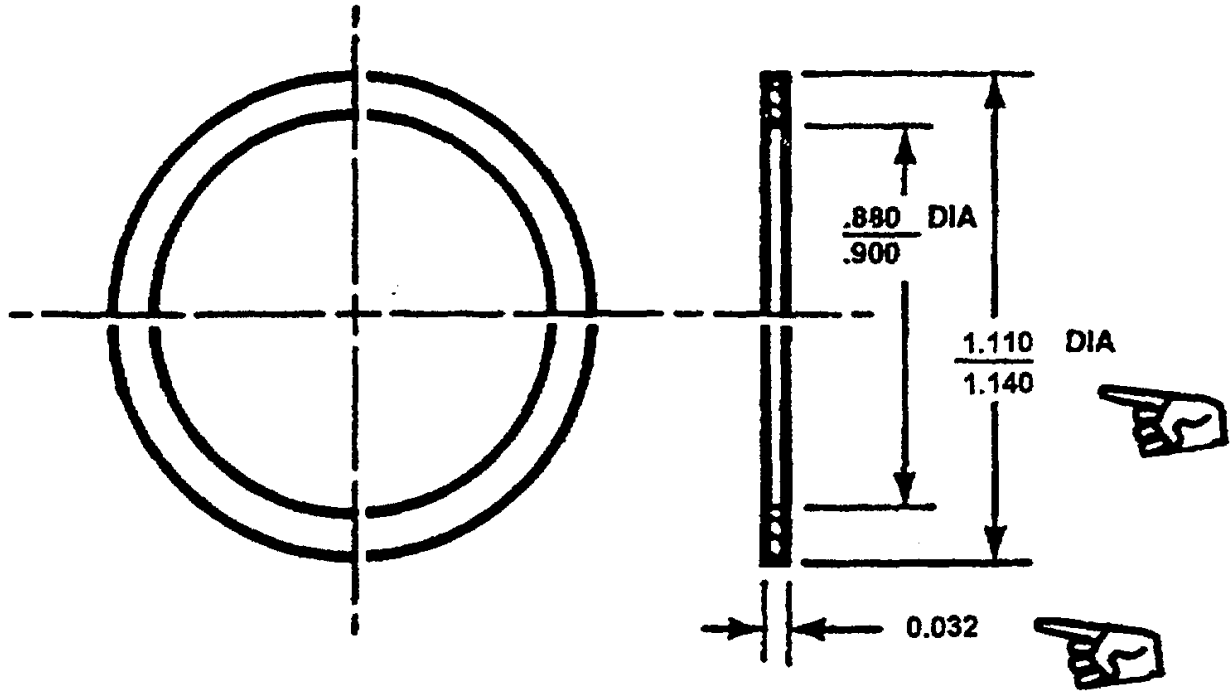
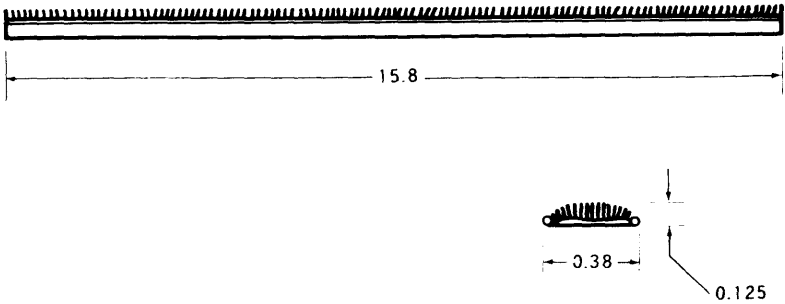


Figure D-356. Part Number 1560-UH1-791. Cross  
 Brace Extension, R-1963/ARN  
 Fabricate from: NSN 9535-00-232-8825  
 Material: Aluminum Sheet, .063 inch  
 thick 2-24-T3, QQ-A-350/4

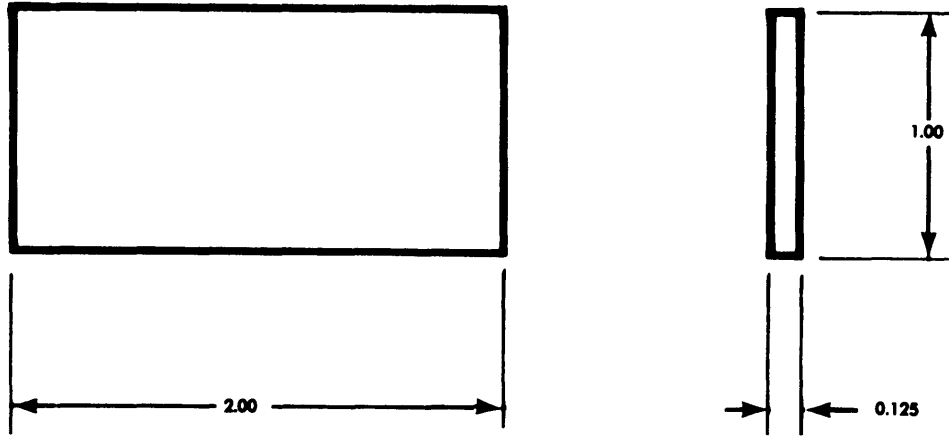


1. DEBURR SARP EDGES
2. FABRICATE FROM NSN 5310-00-282-6904, WASHER FLAT

Figure D-357. Part Number 1560-UH-1-990-1 washer, Flat

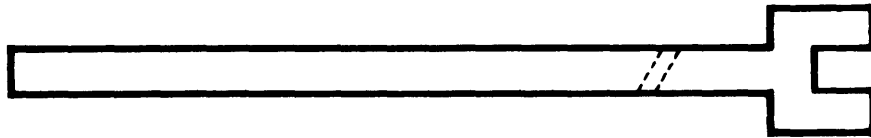


**Figure D-358, Part Number: 204-030-853-93, WIPER**  
**Fabricate from: NSN 6320-00-079-0897**  
**Material: YM3 Strip, Commercial**  
A Product of FSCM 82654.  
Alternate, #T179Y 5022 Poly-Pile,  
A product of FSCM 77824.



**FABRICATE FROM: NSN 9330-00-202-1890,  
PLASTIC SHEET 0.125 INCH THICK**

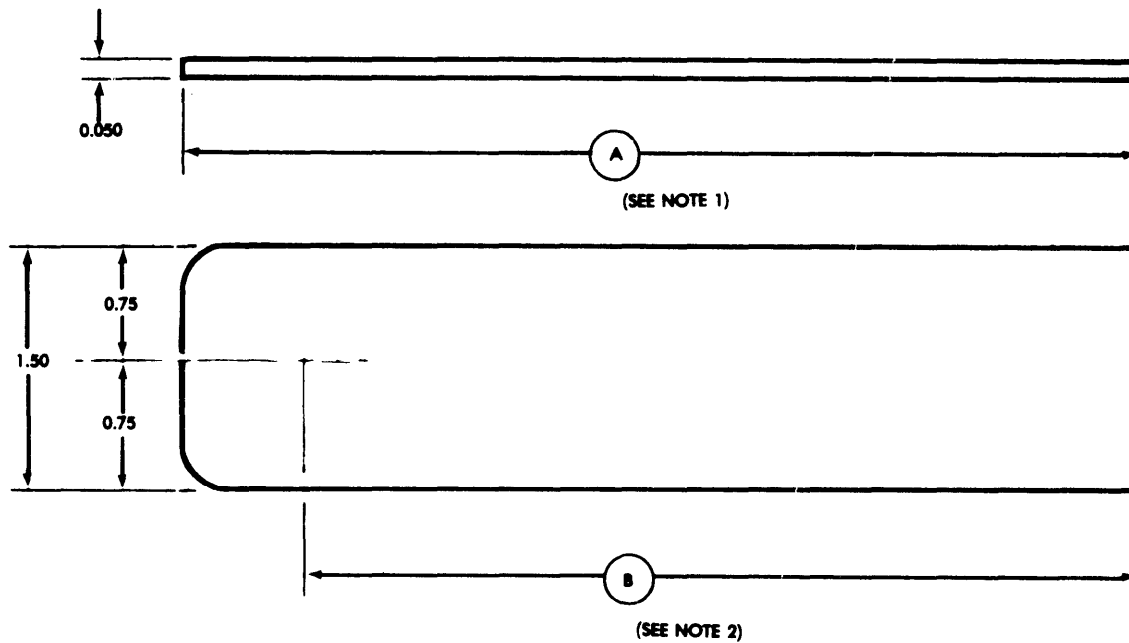
Figure D-359. Port Number 1560-UH-1-761 , Security Device, Window



**Fabricate from NSN 3040-00-701-9919 by drilling a 3/32 in. dia. hole.  
The hole should be parallel to adjacent door structure to accommodate pin.**

**Figure 360. Part Number 1560-UH-1-762-1, Rod, Security Device Pilot's Door.**



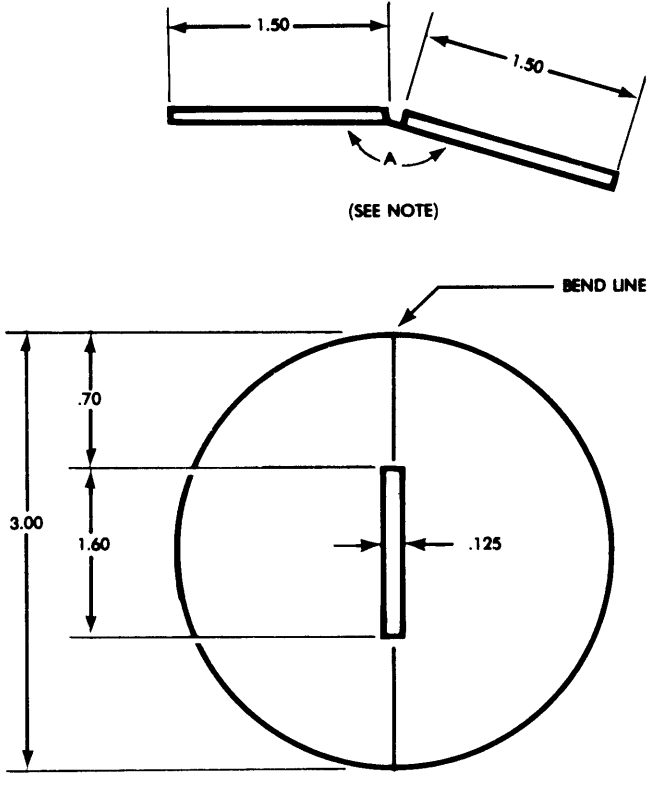


**NOTES: 1. LENGTH A AS REQUIRED TO PICK UP EXISTING RIVET PATTERN ON DOOR POST ASSEMBLY AND TO ALLOW A SMALL TAB TO PROTRUDE BEYOND DOOR MOLD LINE FOR LOCK HOLE**

**2. LENGTH B SHOULD BE MEASURED FOR EACH AIRCRAFT TO INSURE SNUG FIT BETWEEN PLATE (1560-UH-1 -765) AND LOCK**

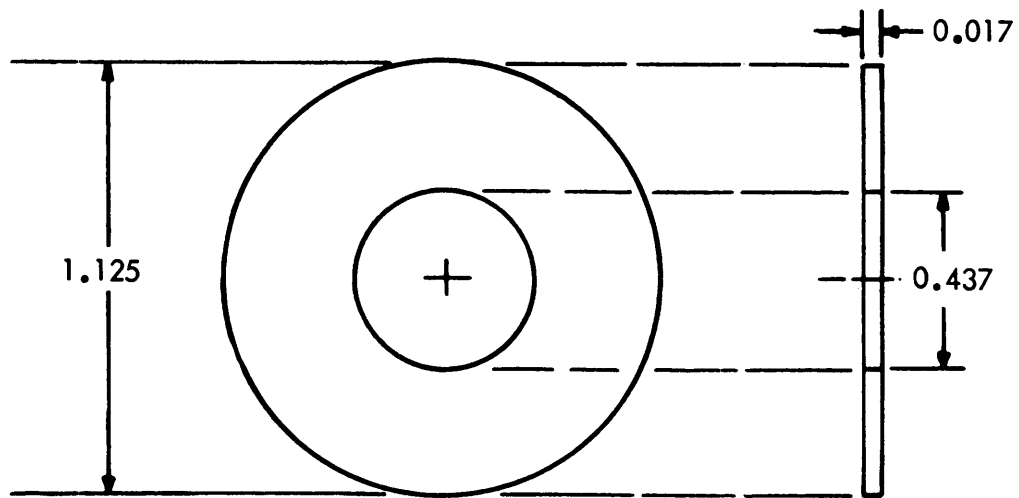
**FRABRICATE FROM: NSN 9515-00-878-4332, STAINLESS STEEL SHEET, 0.050 THICK**

Figure D-361. Part Number 1560-UH-1-764, Security Device



**FABRICATE FROM: NSN 9515-00-878-4332,  
STAINLESS STEEL SHEET 0.050 INCH  
THICK**

Figure D-362. Part Number 1 560-UH-1-765, Plate Copilot Security Device



PART NUMBER: 1560UH1-1 WASHER, ANTI-CHAFFING  
FABRICATE FROM: NSN 5970-00-118-8838  
MATERIAL: INSULATION SHEET, ELECTRICAL FIBERGLASS

FIGURE D-363.

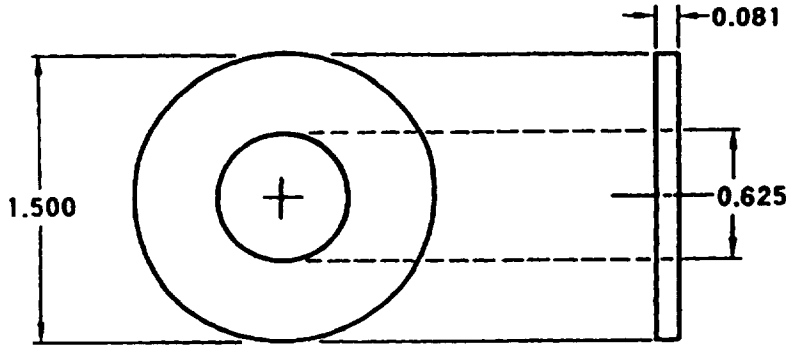
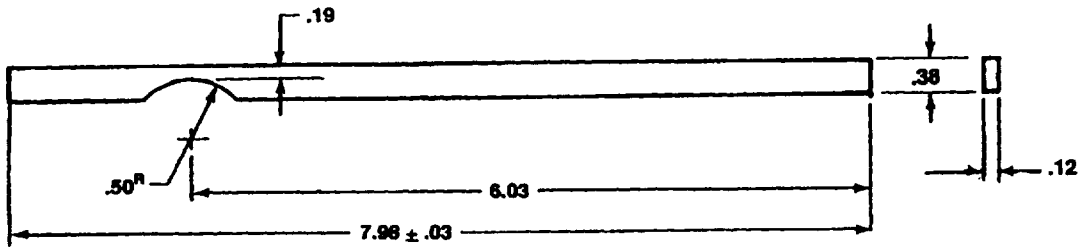


Figure D-364. Number: 5310-UH1-038-1, WASHER  
 Fabricate from: NSN 9380-00-143-7110  
 Material: Rubber Sheet



PART #8531834

Figure D-364.1. Part Numbers 8531804 AND 8531834, GASKET  
 Fabricate from: NSN 9320-00-814-4583; P/N 8635958-7  
 Material: Rubber, Sheet, Cellular

P/N 205-030-009-51

Fabricate from 98 inches of NSN 9320-01-012-7683

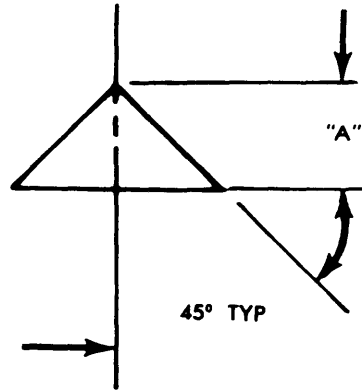
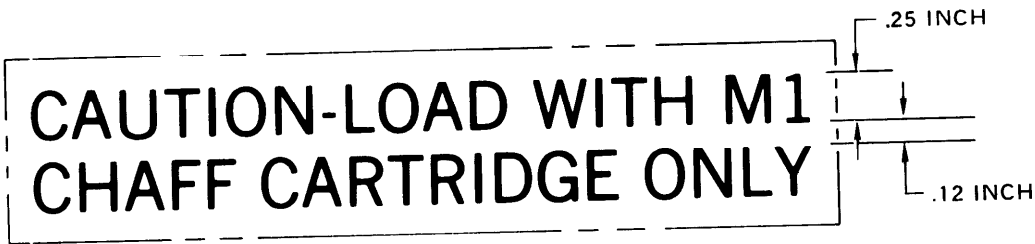


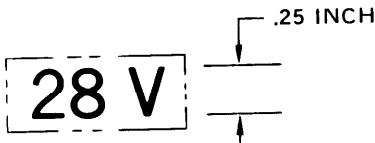
FIGURE D-365, EXTRUSION-RUBBER



STENCIL (205-071-118-101)



STENCIL (205-071-118-103)



STENCIL (205-071-118-105)



STENCIL (205-071-118-107)

Figure D-366.

Part Number:

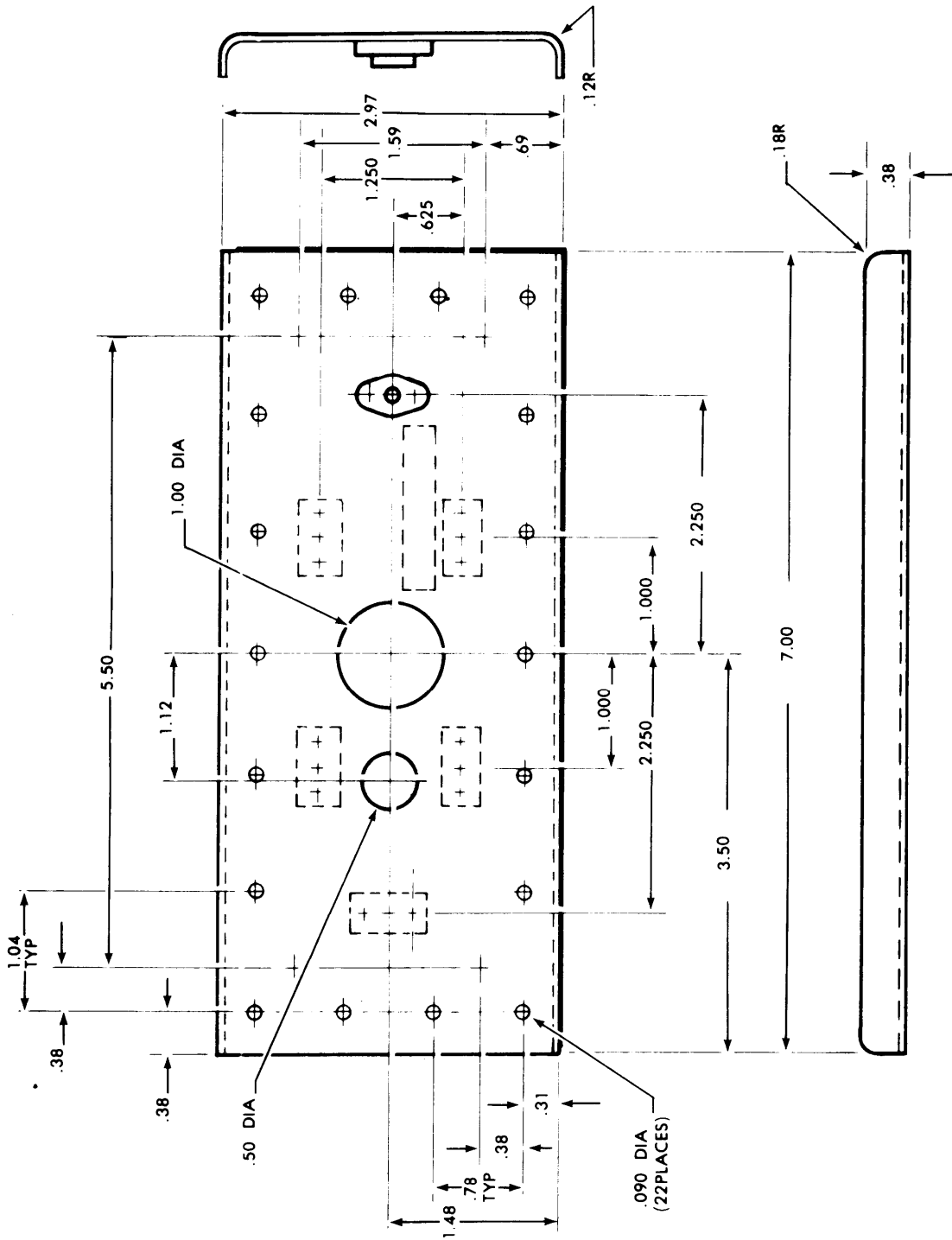
- 205-071-118-101
- 205-071-118-103
- 205-071-118-105
- 205-071-118-107

Fabricated from:

9310-00-265-6797

Material:

Stencil Board, Federal Specification  
 UU-S-625, Type 2, Grade 1

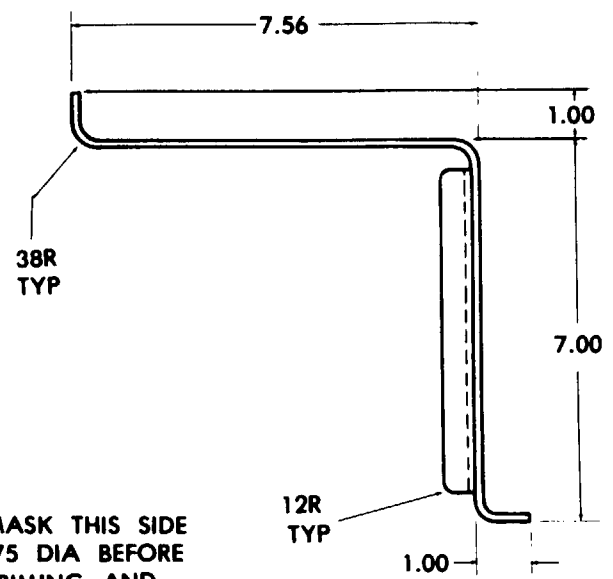
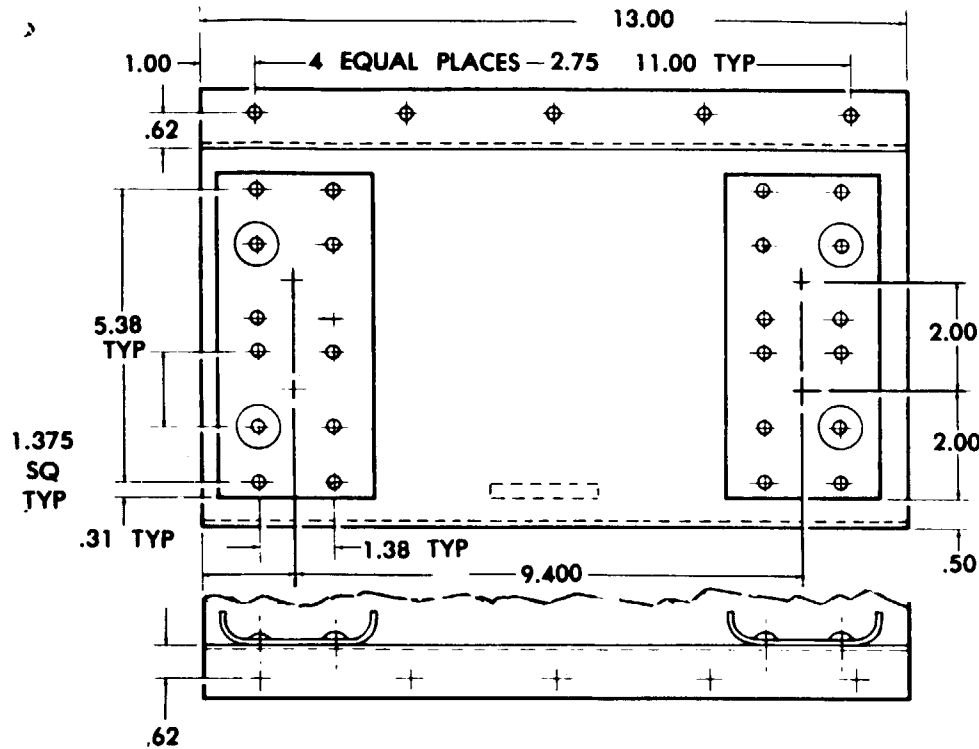


**Figure D-367. Plate Doubler Assembly, PN1560-UH-1-1044**

Fabricate From: NSN 9535-00-086-9930 Metal Sheet  
 5310-00-781-9493 Nut  
 5320-00-117-6938 Rivet

Material: Aluminum Alloy, .040 Thick, 2024-T3 per QQ-A-250/4

.209 DIA THRU  
(TYP 26 PLACES)



MASK THIS SIDE  
.75 DIA BEFORE  
PRIMING AND  
PAINTING  
(4 PLACES)

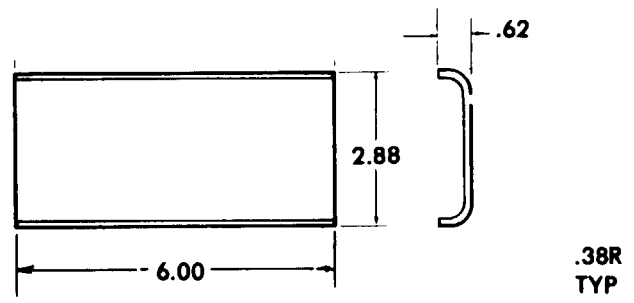
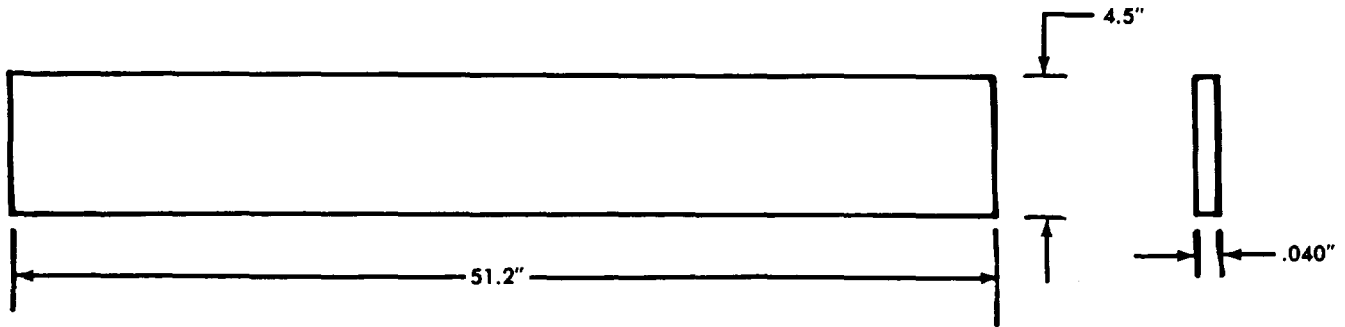


Figure D-368. Bracket, PN1560-UH1-1023

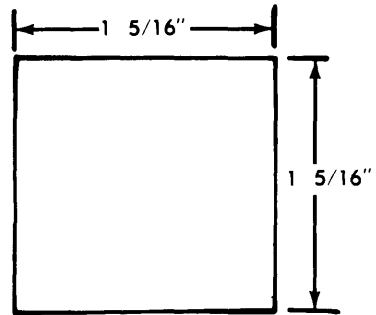
Fabricate From: NSN 9535-00-230-7571 Metal Sheet  
5320-00-999-2188 Rivet  
Material: Aluminum Alloy GR2024-T3 .071 Thick per QQ-A-250-4





PART NUMBER: 205-031-669-101  
FABRICATE FROM: NSN B305-00-205-2735  
MATERIAL: SEAL, STANFLEX FAB

FIGURE D-369.



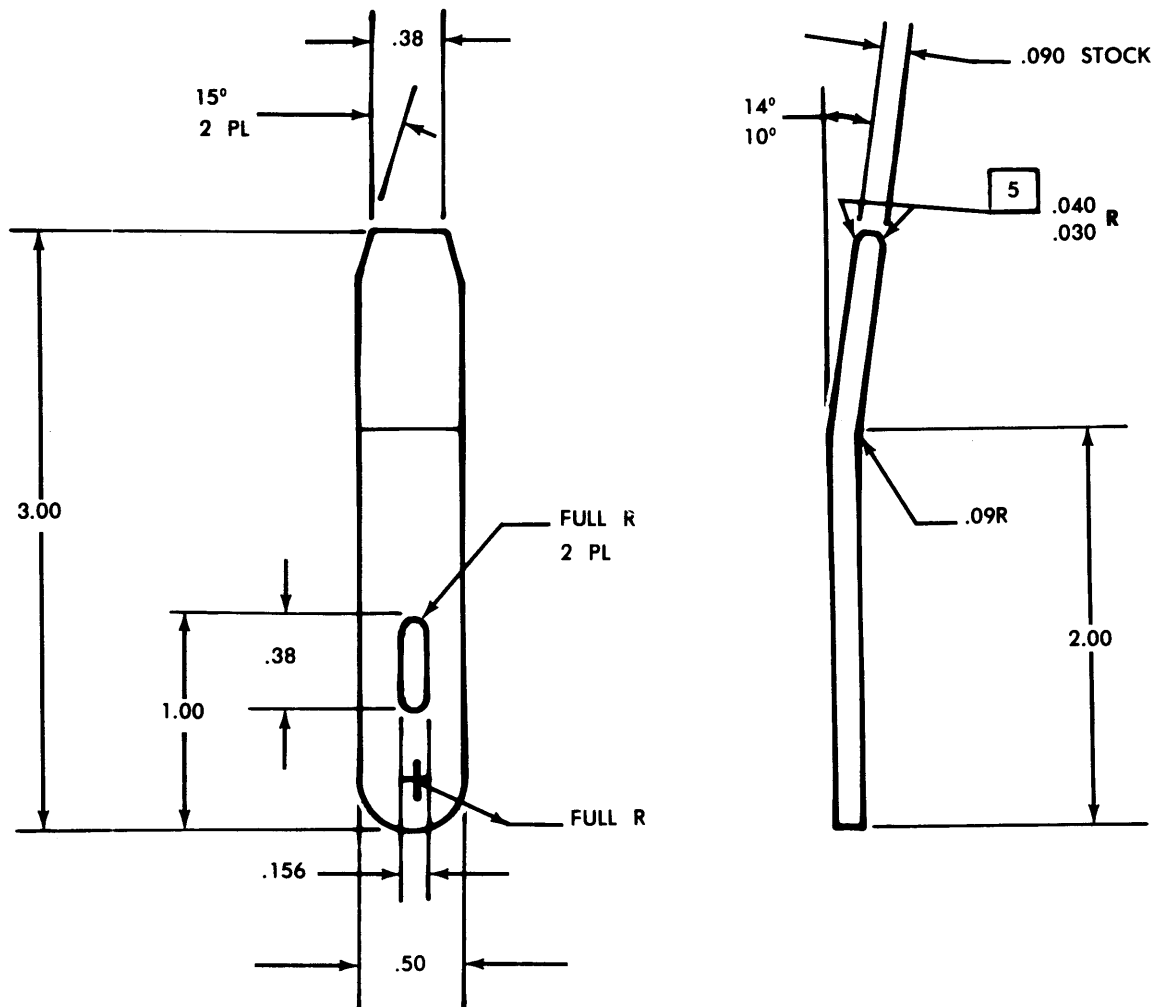
Part Number: 204-030-832-7

Fabricate from: NSN 9320-00-814-4583

Material: Rubber sheet, MIL-R-6130, Type 2,

Grade A fire and oil resistant

FIGURE D-370.



PART NUMBER 745016  
FABRICATE FROM: NSN 9535-00-818-0871  
MATERIAL: ALALY; 6061-T6 PER QQ-A-250/11

FIGURE D-371.

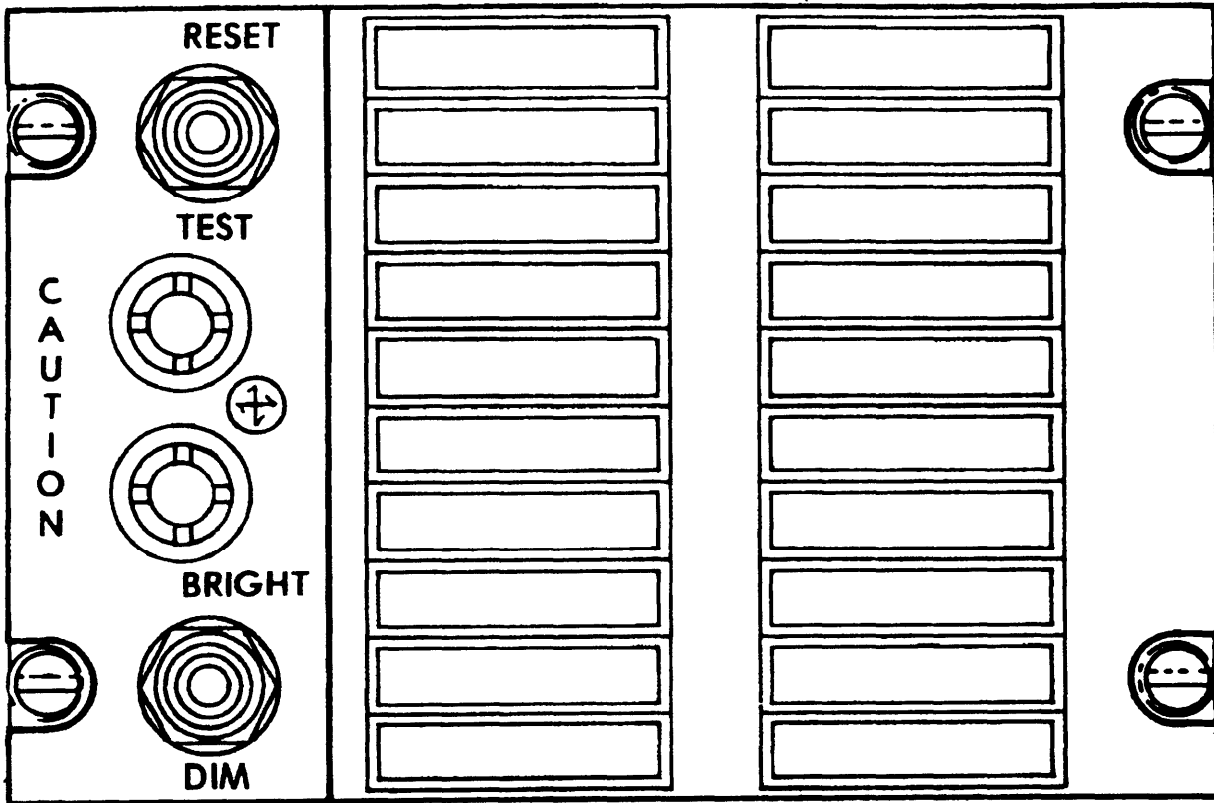
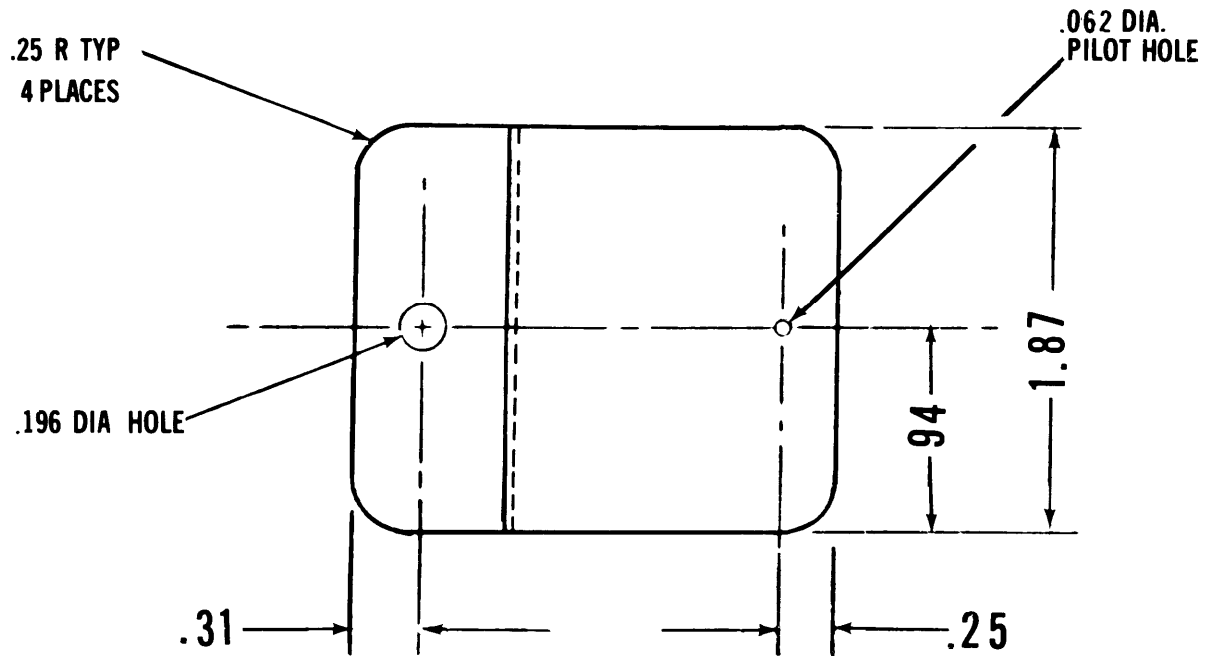
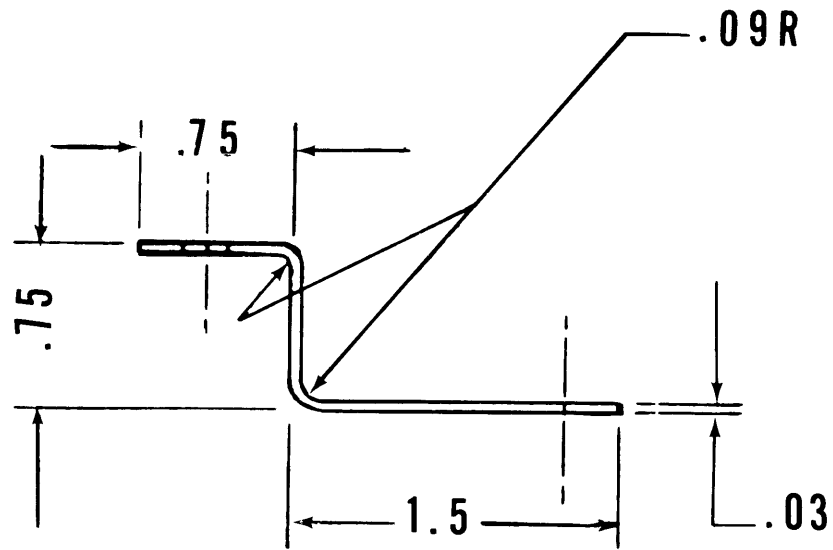


Figure D-372. Master Caution Panel, PN ES-C-221355

Fabricate from: NSN 1680-00-021-5510, PANEL  
P/N 25-0259-30, LENS  
P/N 25-0259-220, LENS



Figure D-373. DELETED



**NOTES:**

1. MATERIAL: ALUM. ALLOY 2024-T4, .031 THK. PER SPRCC QQ - A-250/4
2. FINISH P 513.1 LUSTERLESS BLK. NO. 37038 PER FED - STS - 595 AND MIL - F14072.
3. IDENTIFY PER MIL STD-130.

Figure D-374. Bracket, Relay PN ES-C-221697  
Fabricate From: NSN 9535-00-084-4395

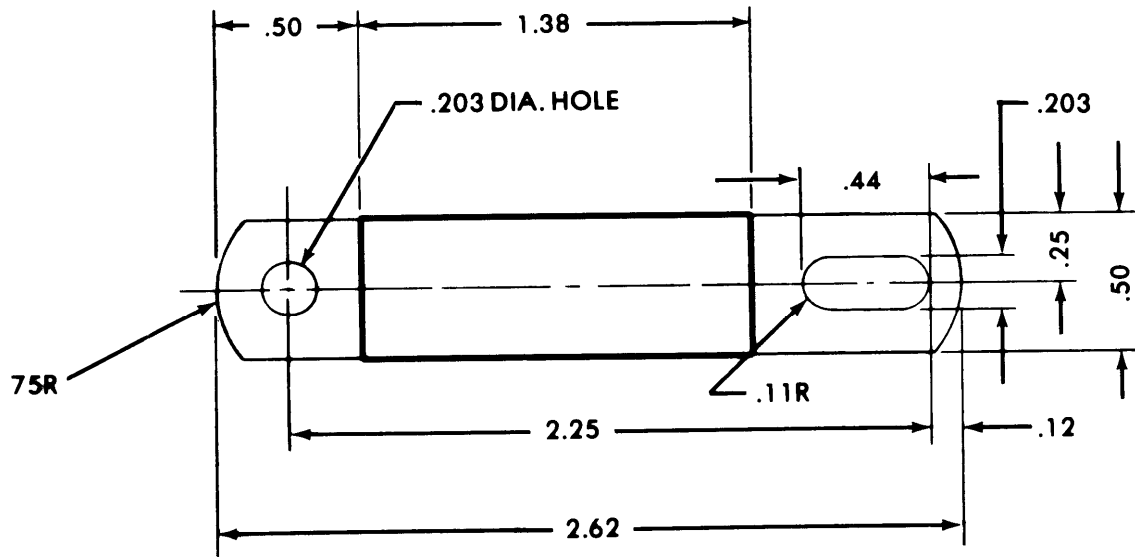


Figure D-375. Jumper Assy, Bus Bar, PN ES-B-221720

Fabricate From: NSN 5970-00-815-1295, 6150-00-225-0267  
Material: Copper Sheet, .063 Thk, annealed per spec. QQ-C-576

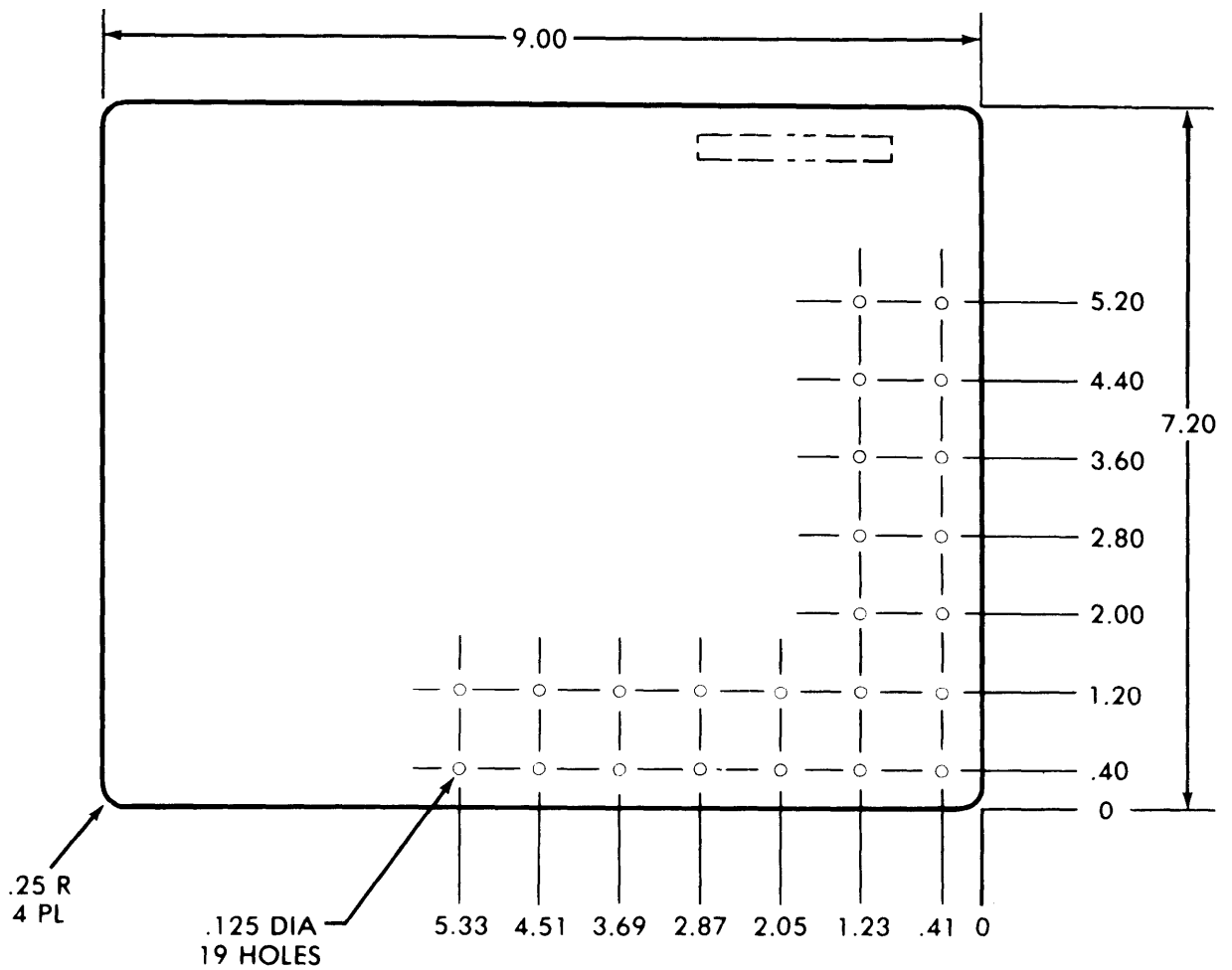


Figure D-376. Plate, Reinforcing, DF Ant., Forward PN5065695

Fabricate From: NSN 9535-00-085-4133

Material: Al. Alloy, 6061-T6, .032 Thk, QQ-A-250/11



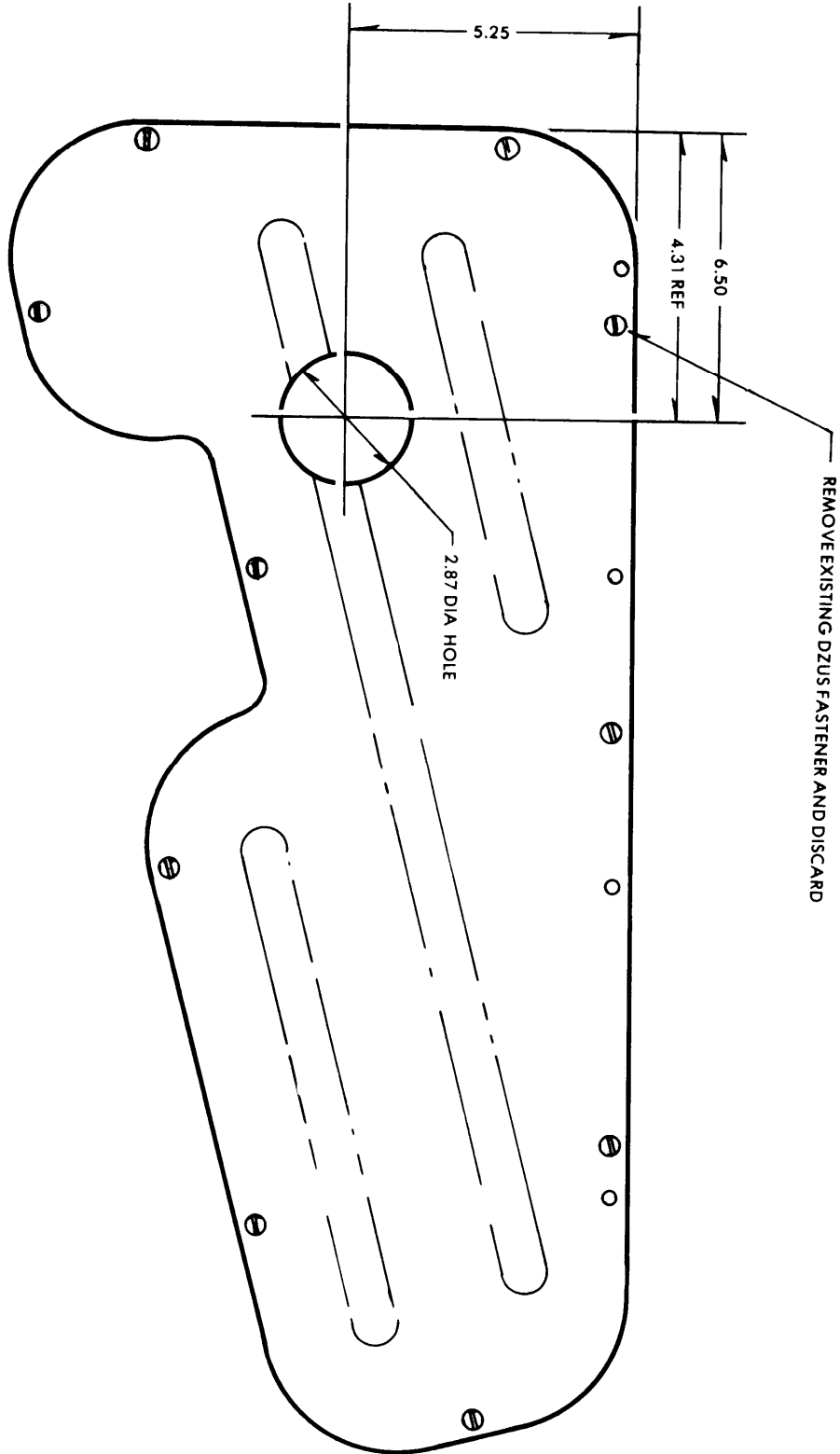
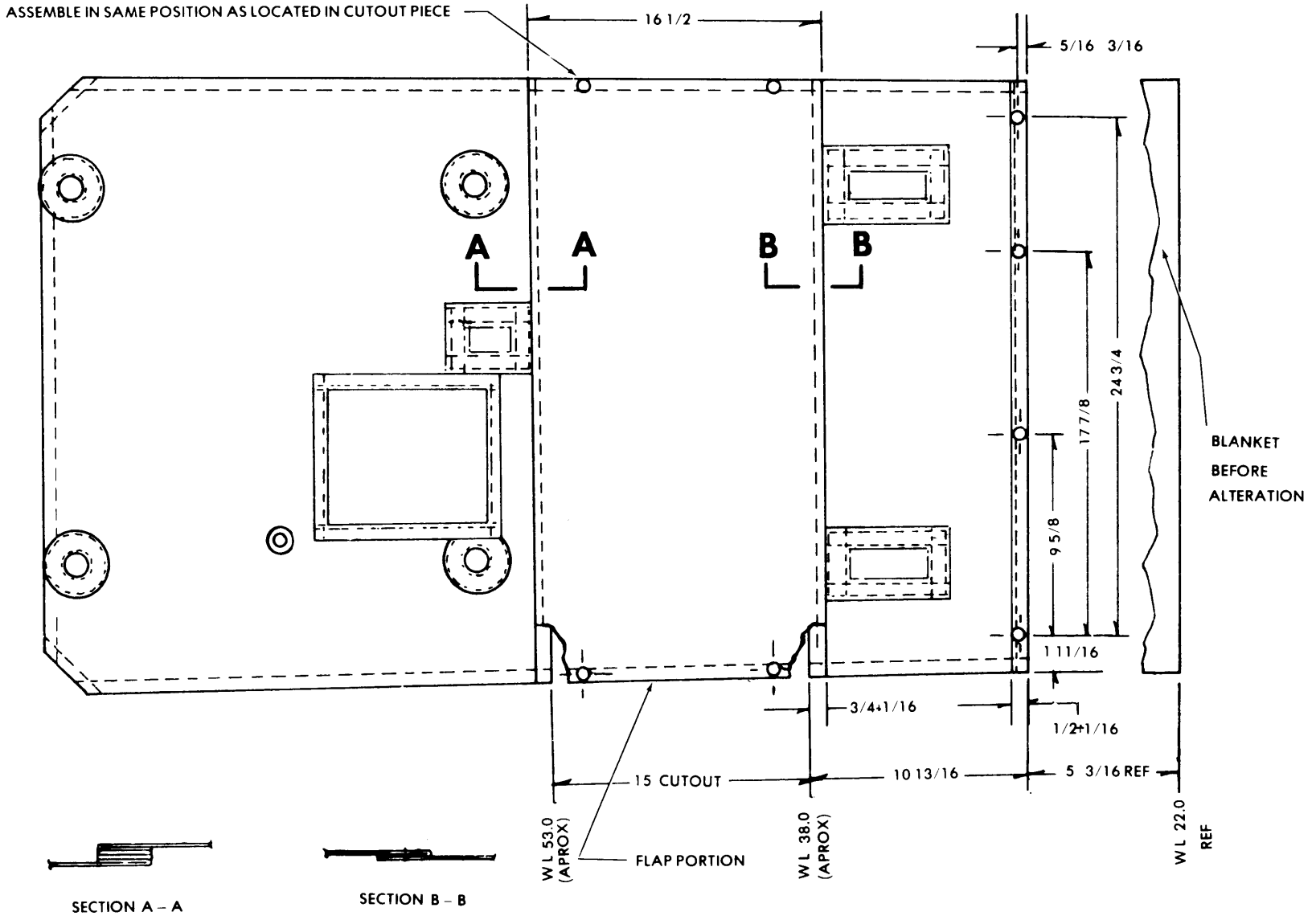


Figure D-377. Pedestal, Access Door, PN ES-F-221565

Fabricate From: NSN 1560-00-885-1835

Figure D-378. Blanket Assembly, PN ES-F-221752



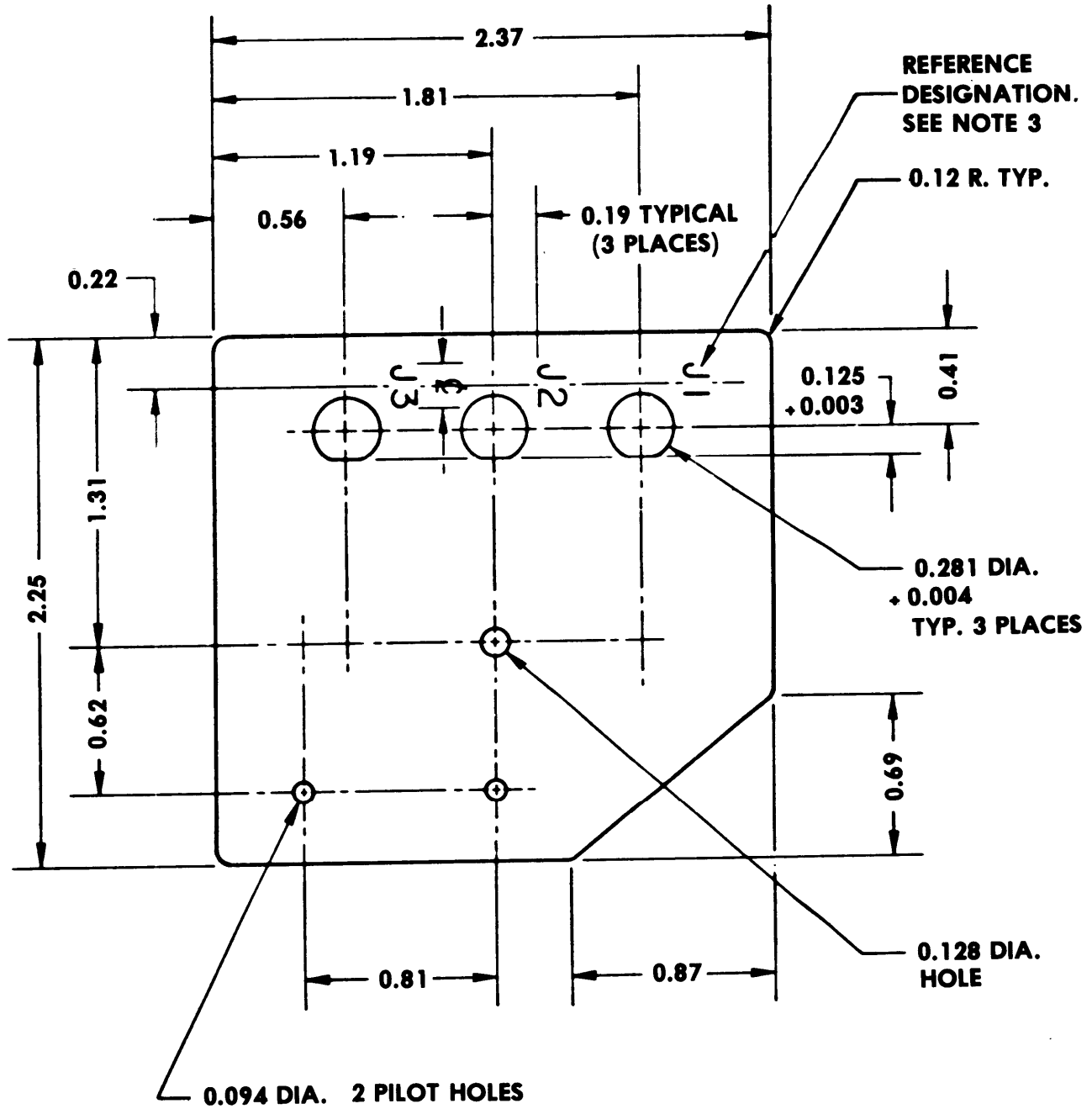


Figure D-379. Bracket Angle PN ES-C-221739

Fabricate From: NSN 9535-00-232-0405

Material: Aluminum Alloy, 0.063 Thick, 2024-T3 per spec. QQ-A-250/5

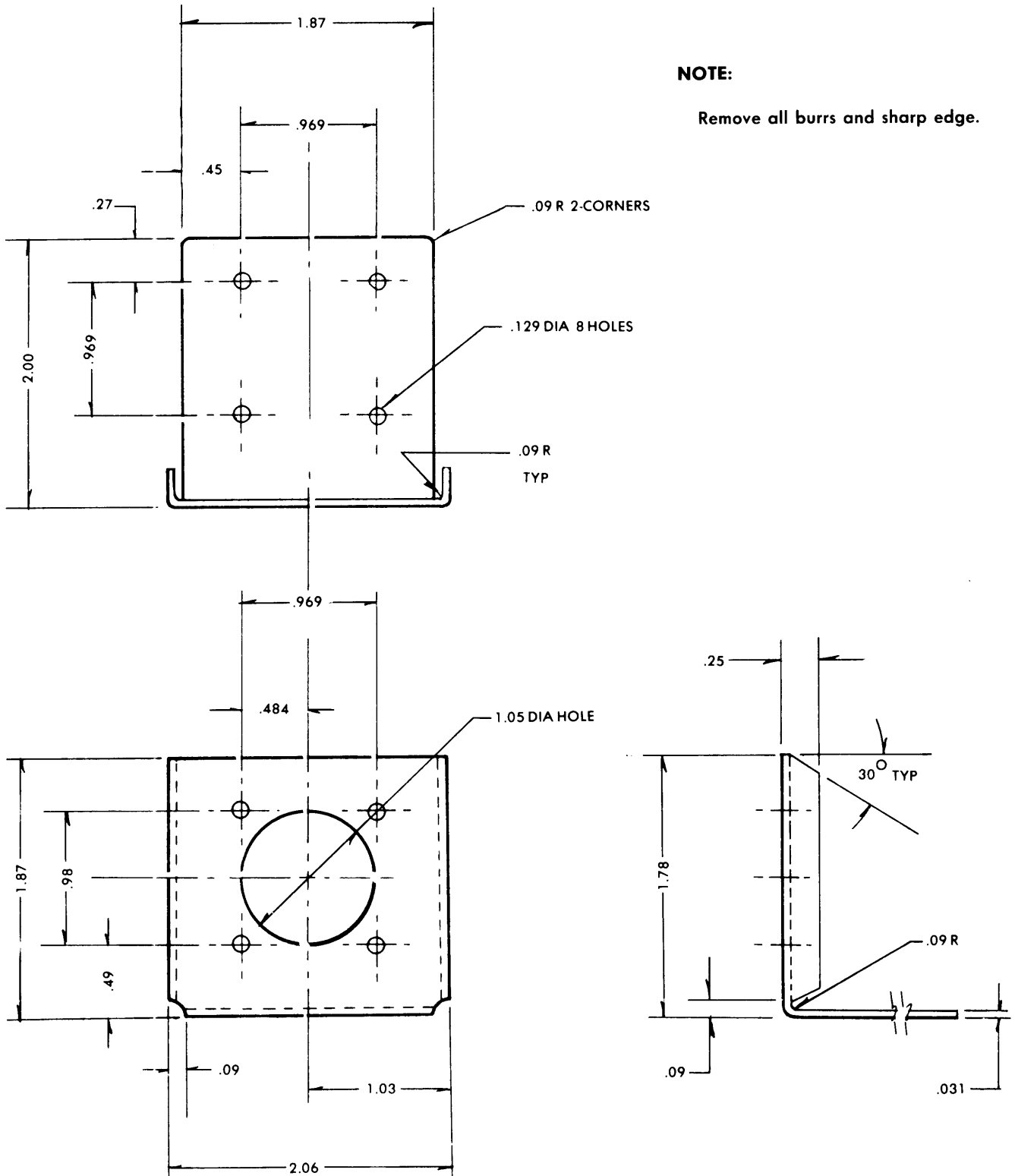


Figure D-380. Support, Connector, PN ES-C-221709

Fabricate From: NSN 9535-00-167-2248  
 Material: .031 Thick Aluminum Alloy, 2024 Temper  
 T4 per spec. QQ-A-250/4

**NOTES:**

1. Plug Hole with lucite plug, glued in place with ketone
2. Characters to be  $\frac{1}{8}$ " high unless otherwise specified to meet applicable requirements of spec. MIL-P-7788, Class 1-W.

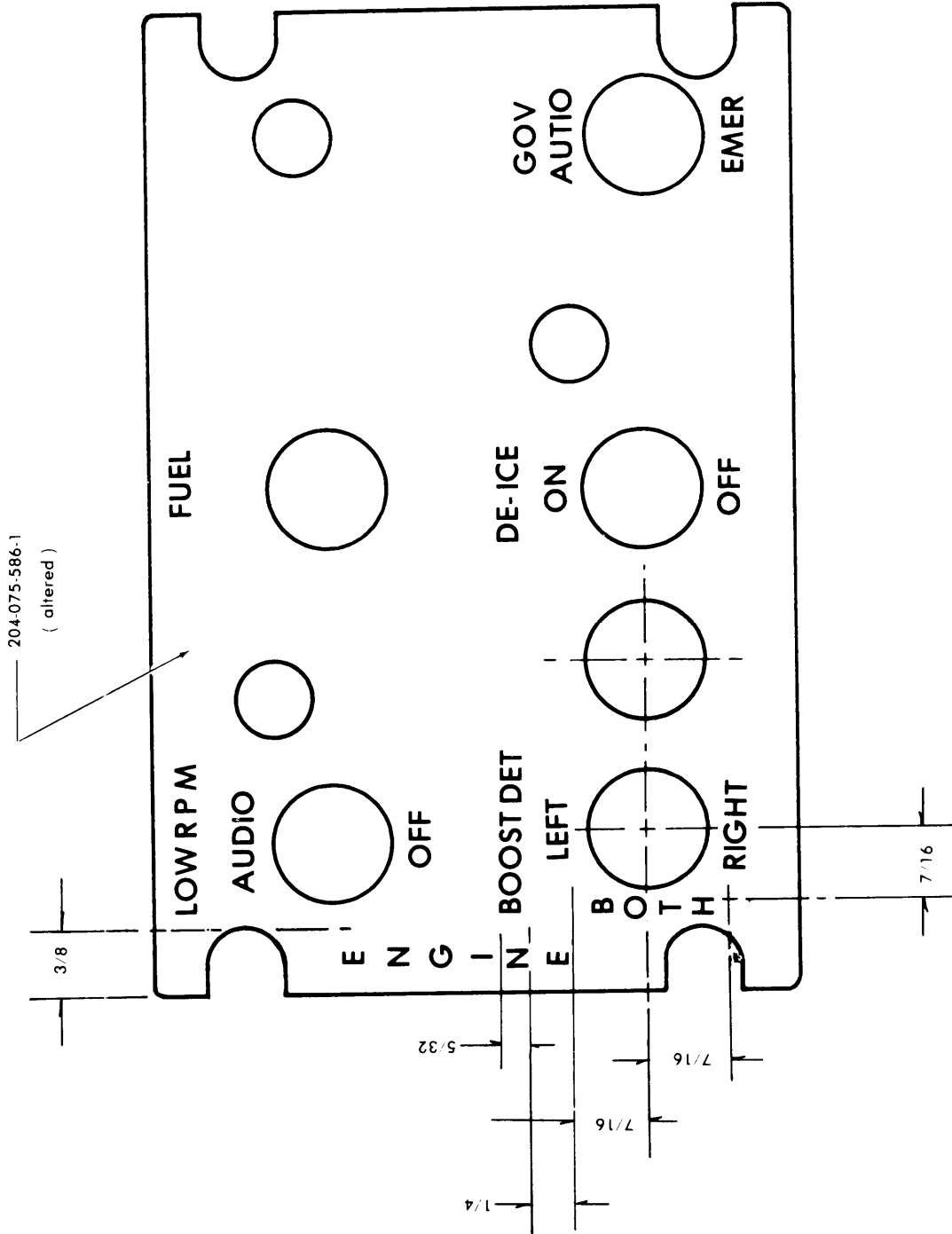


Figure D-381. Panel, Control PN ES-C-221569

Fabricate From: NSN 6110-01-063-3689

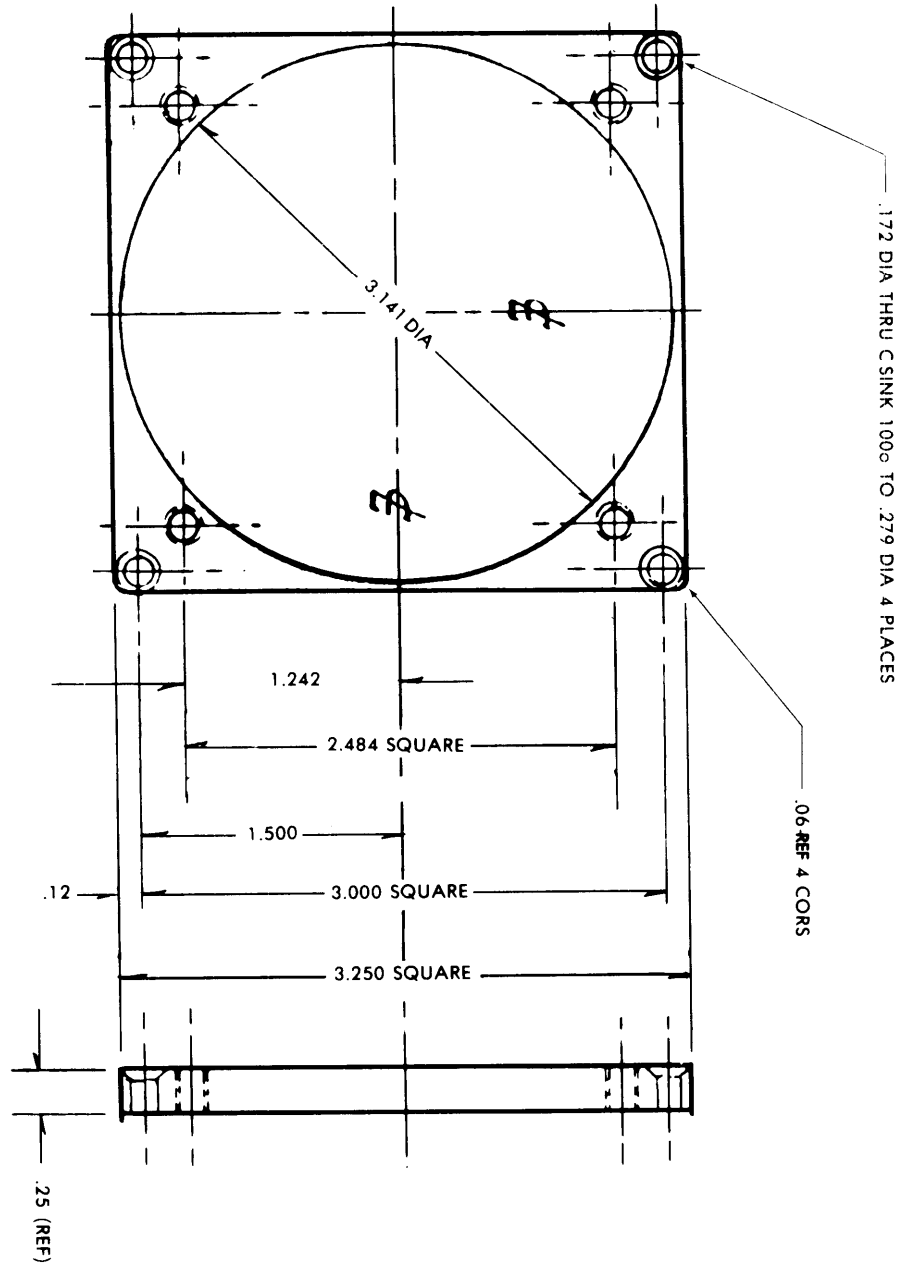


Figure D-382. Plate, Mounting PN ES-C-221440  
 Fabricate From: NSN 9535-00-085-4134, NSN 5340-00-815-4930  
 Material: Aluminum Alloy, .250 Thick, 2024-T3 per spec QQ-A-250/4

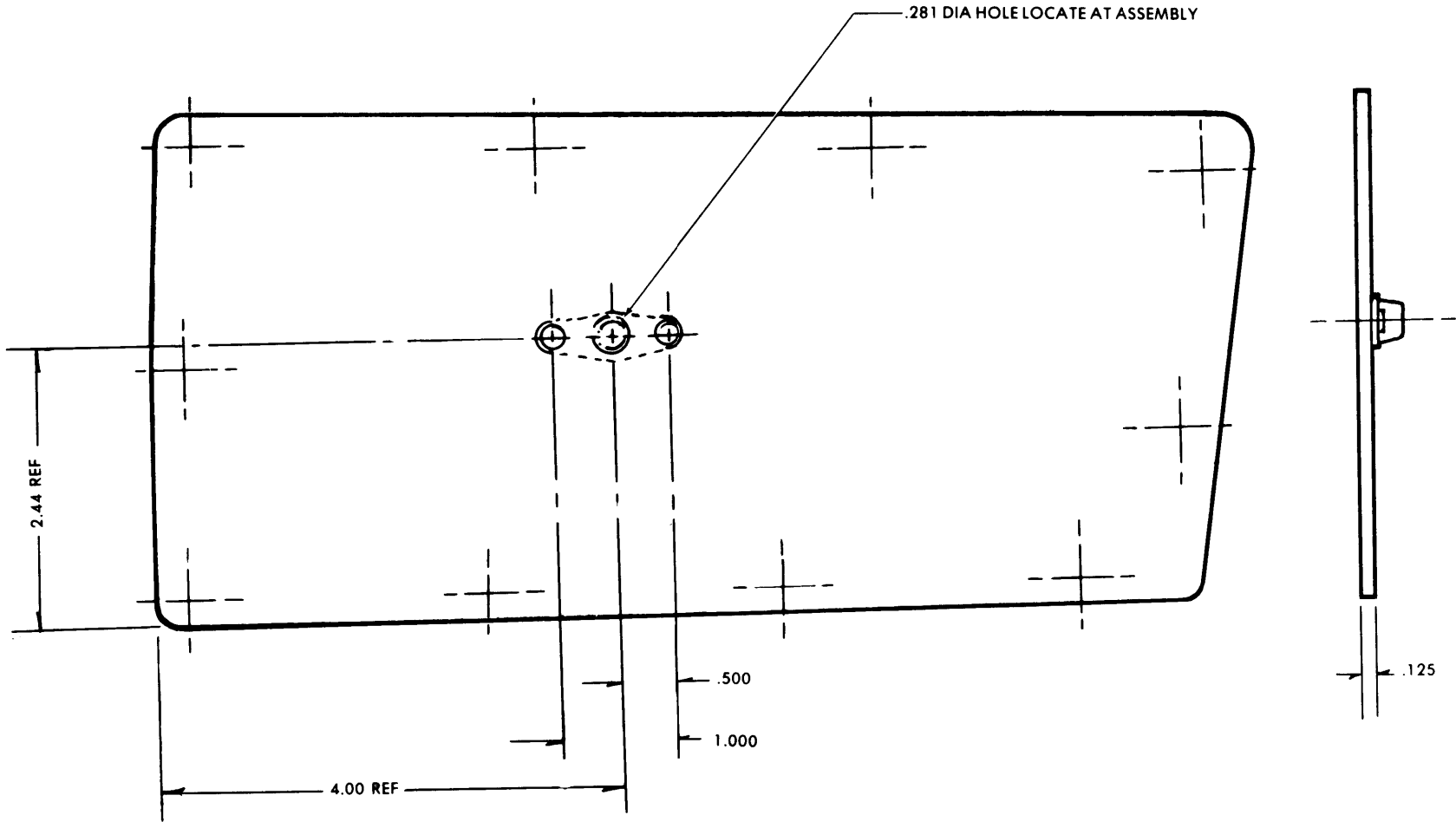


Figure D-383. Plate, Structural Aircraft, PN ESC-213928  
Fabricate From: NSN 9535-00-085-4169  
Material: Alum. Alloy, Sheet, 6061-T6, per QQ-A-250/11

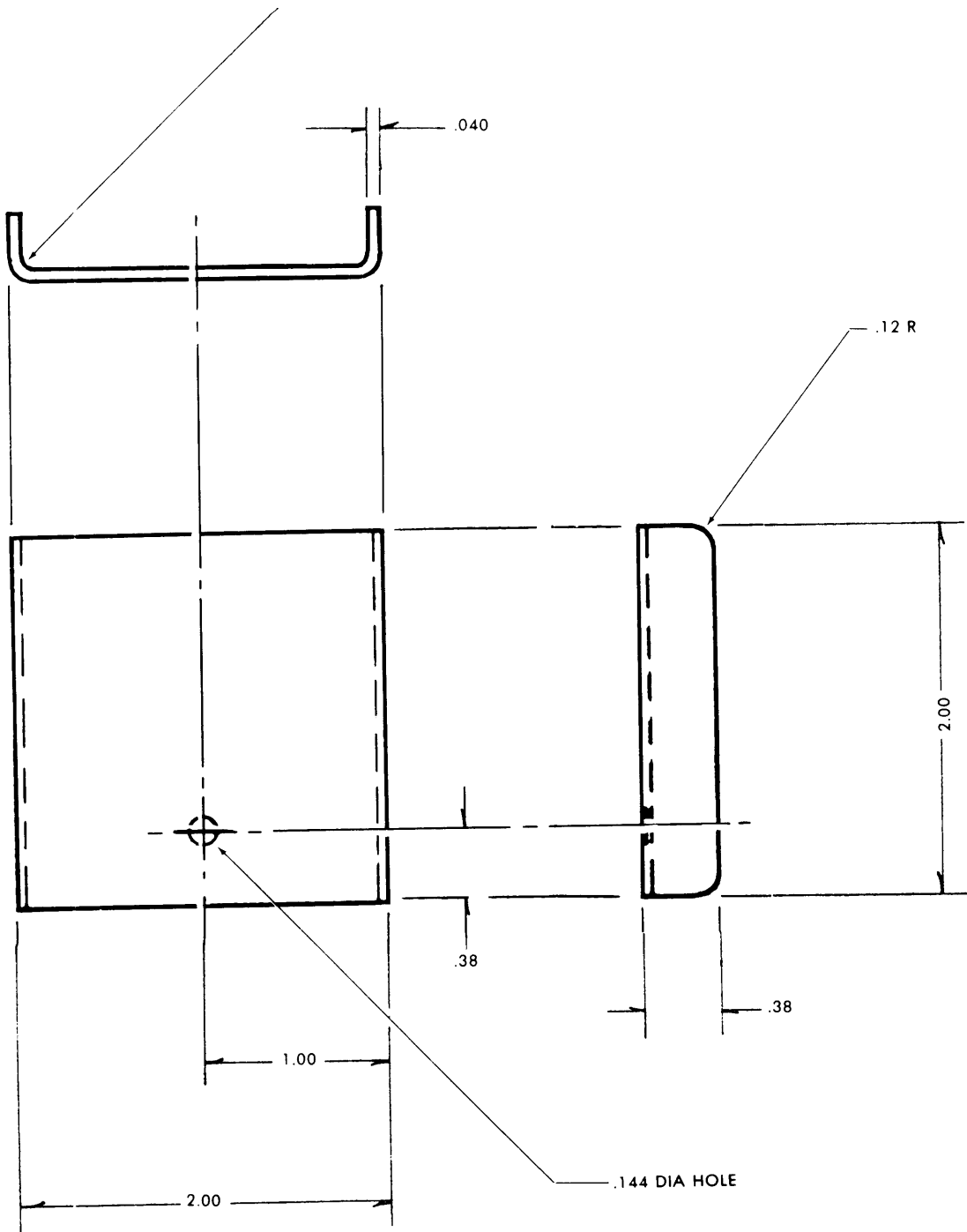


Figure D-384. Plate, Structural Aircraft PN ES-B-221712  
 Fabricate From: NSN 9535-00-084-4413  
 Material: Aluminum Alloy, 6061-T6 per QQ-A-250/1 1



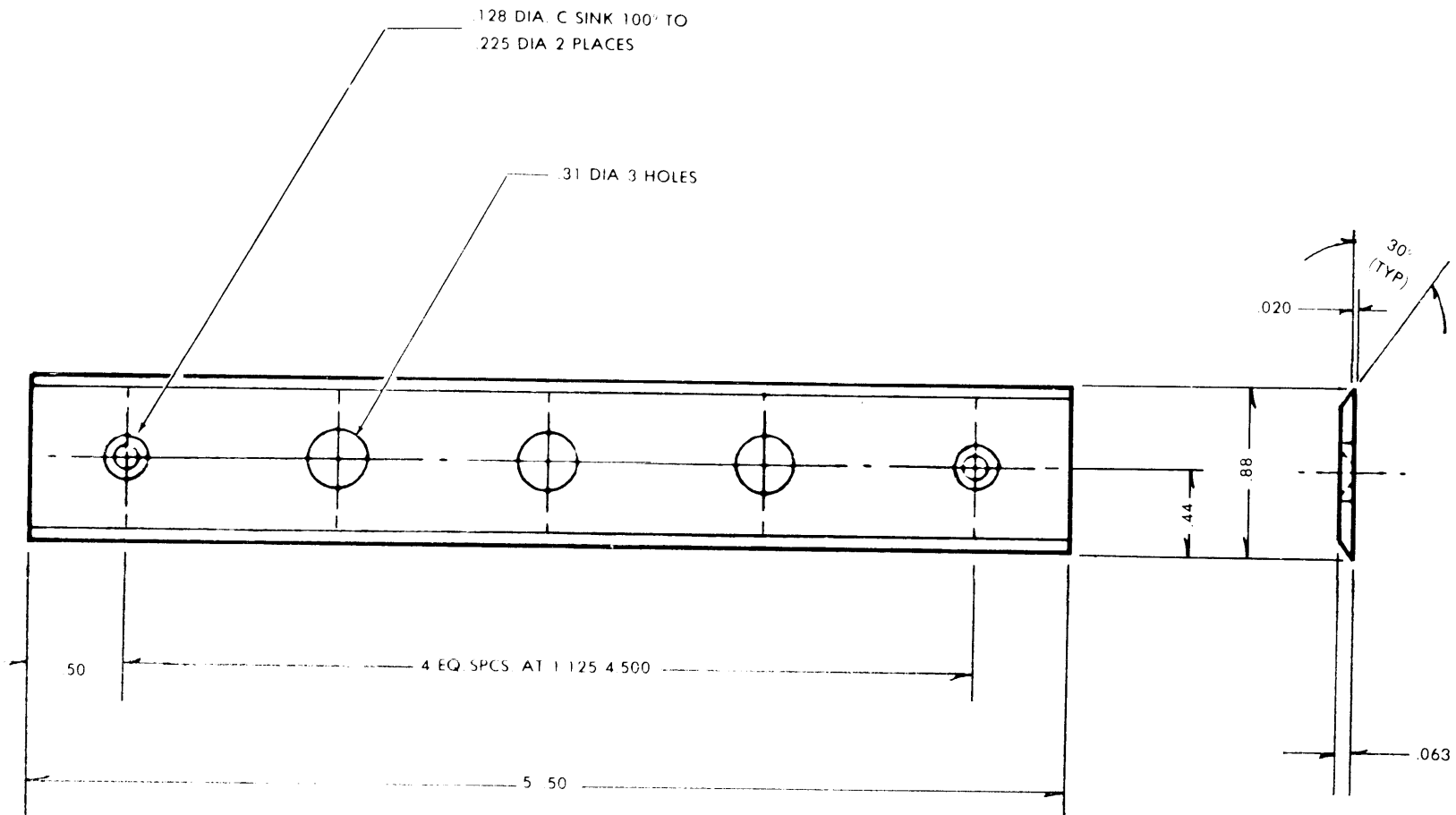


Figure D-385. Spacer, Plate PN ES-B-221566  
Fabricate From: 9535-00-232-1882  
Material: Aluminum Alloy, 6061-T6, Sheet, per QQ-A-250/1

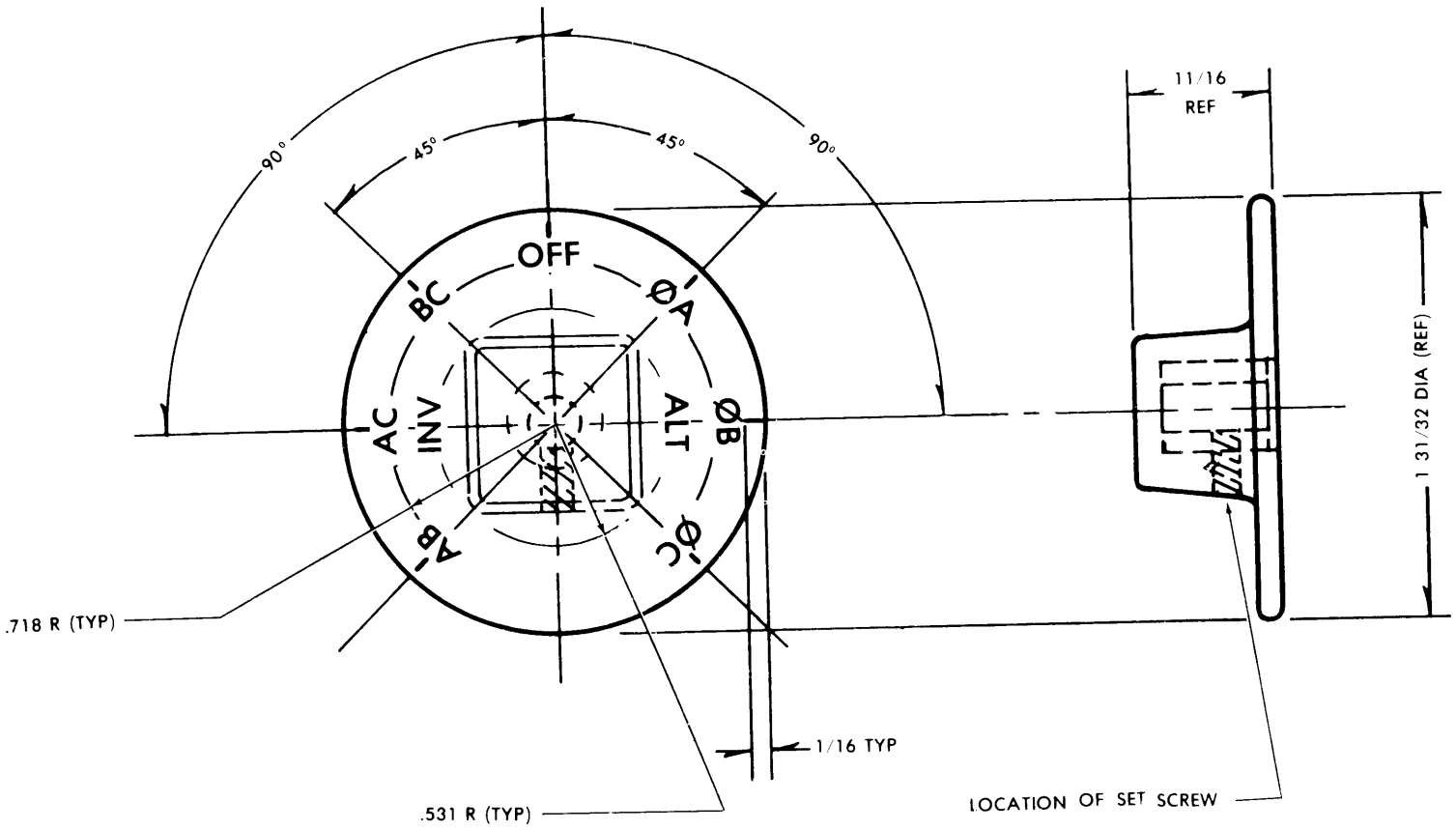


Figure D-386. Knob Assy, Indicator PN ES-B-221427  
Fabricate From: 1560-00-771-2502

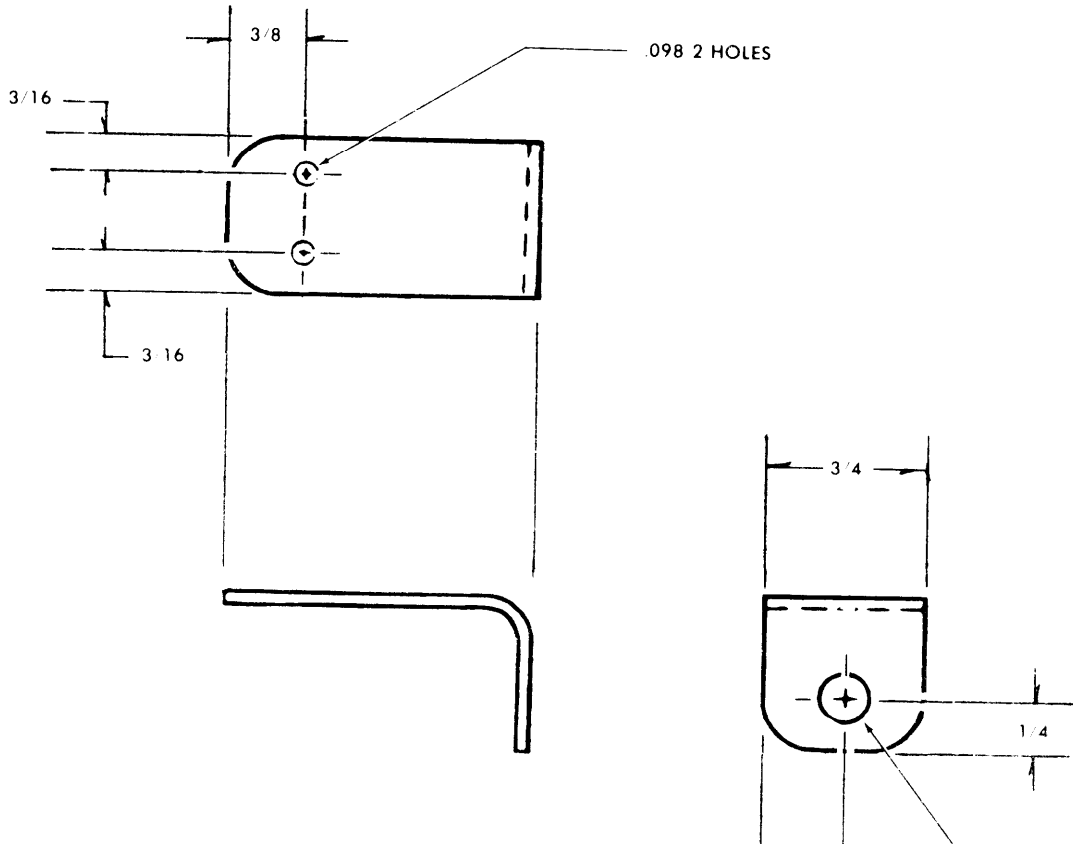


Figure D-387. Bracket, Angle PN ES-B-220355  
Fabricate From: 9535-00-232-0378  
Material: .063 Aluminum Alloy, 2024-T3 per QQ-A-250/5

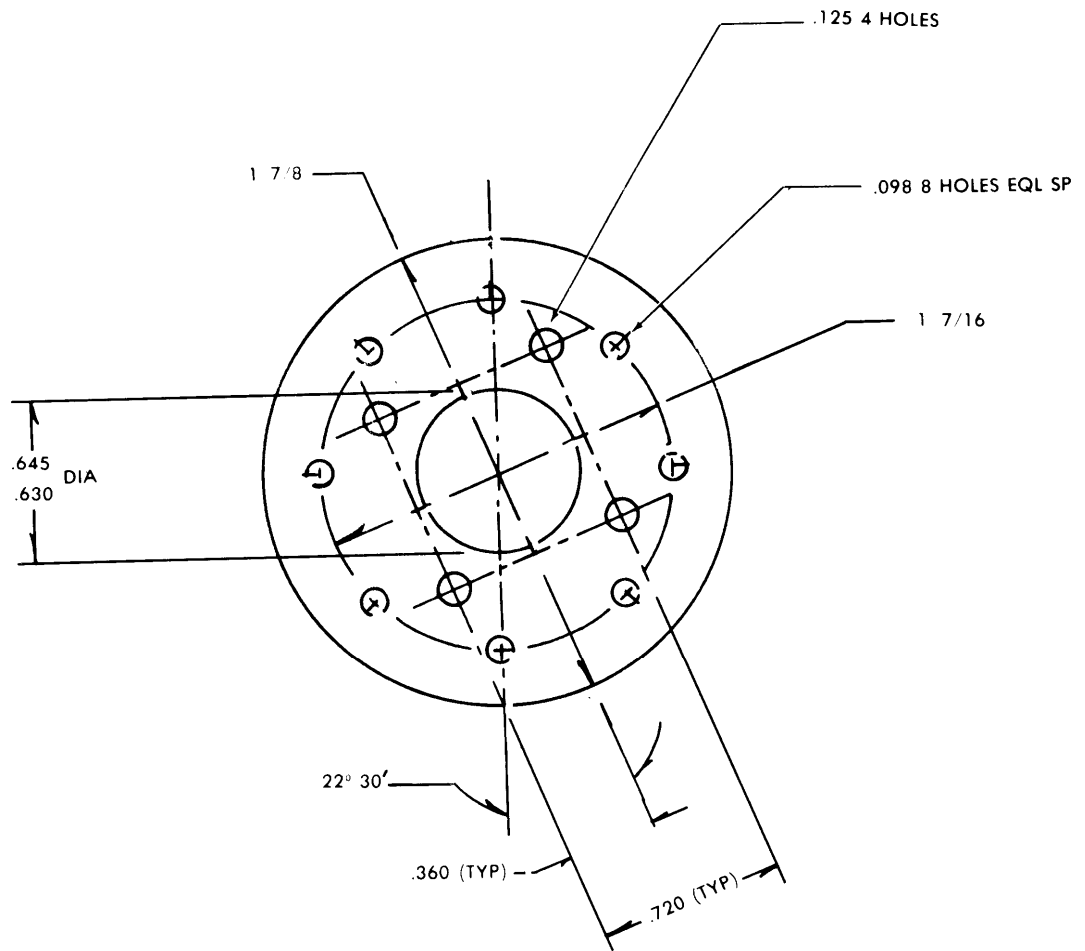
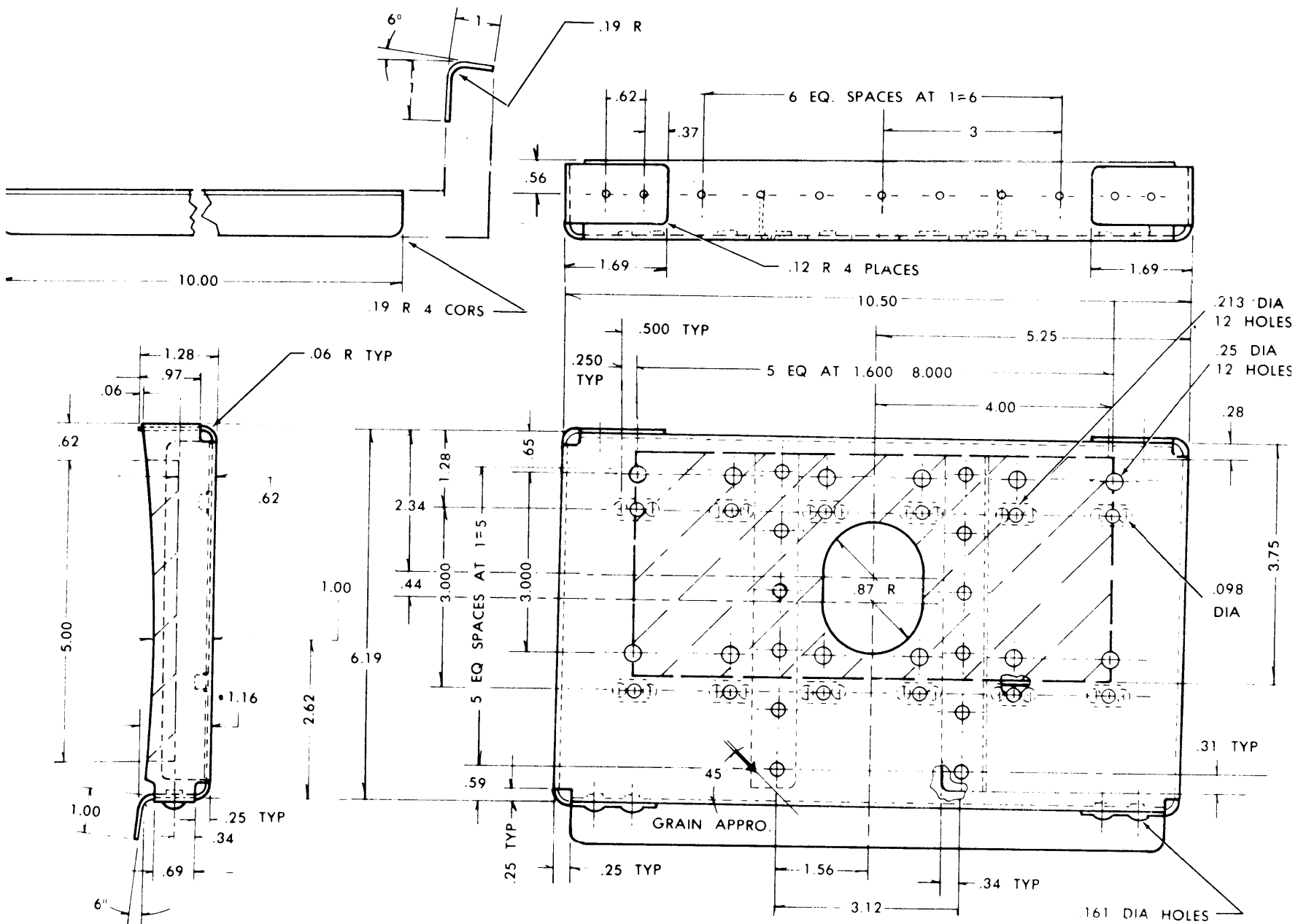


Figure D-388. Plate, Structural, Aircraft PN ES-B-220354  
 Fabricate From: NSN 9535-00-232-0565  
 Material: .03 ZX2X2 AL Aly 2024-T3 per QQ-A-250/5



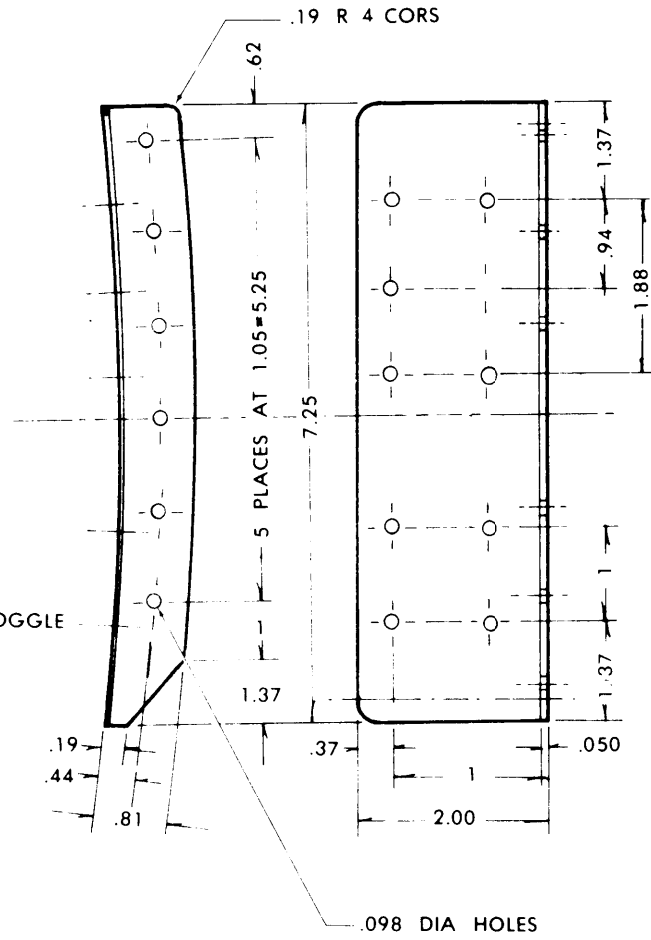
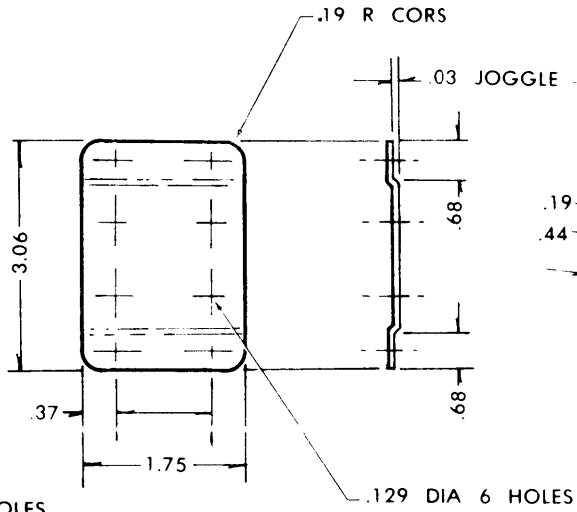
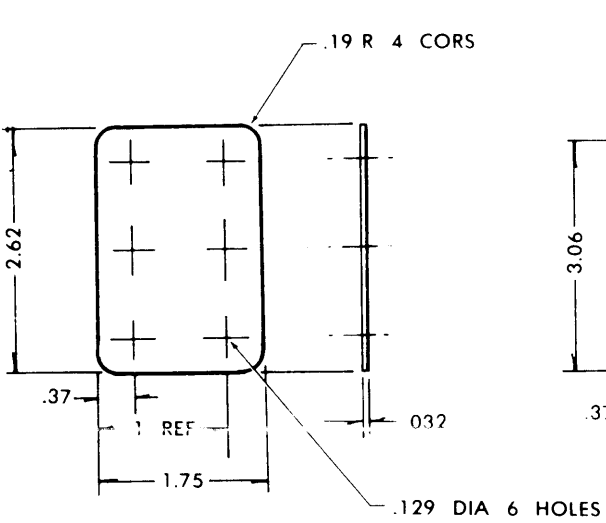
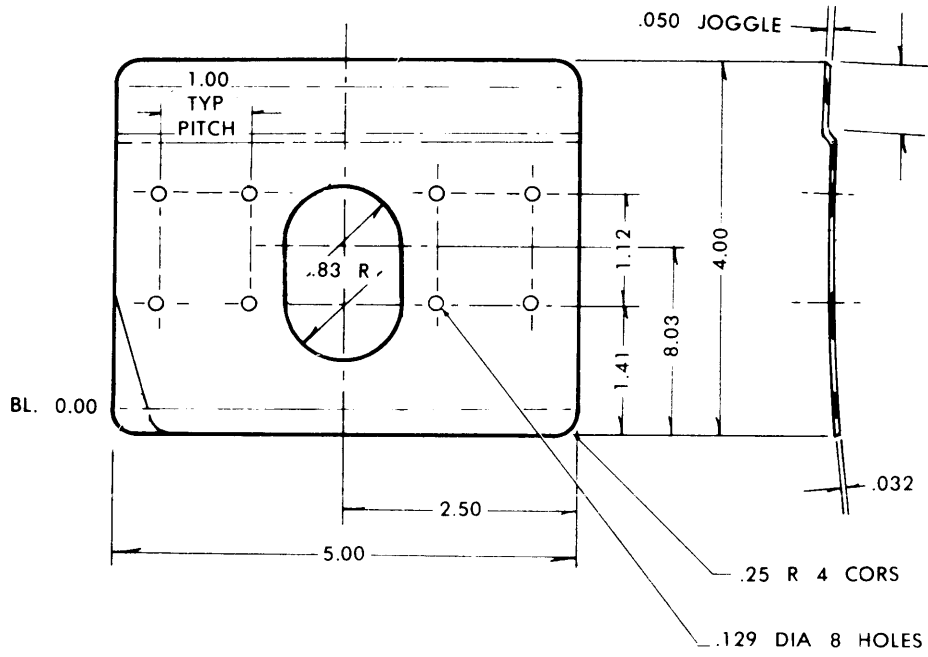


Figure D-389 (sheet 2 of 2). B. I. T. E., Ant., Mtg. PN ES-D-221672

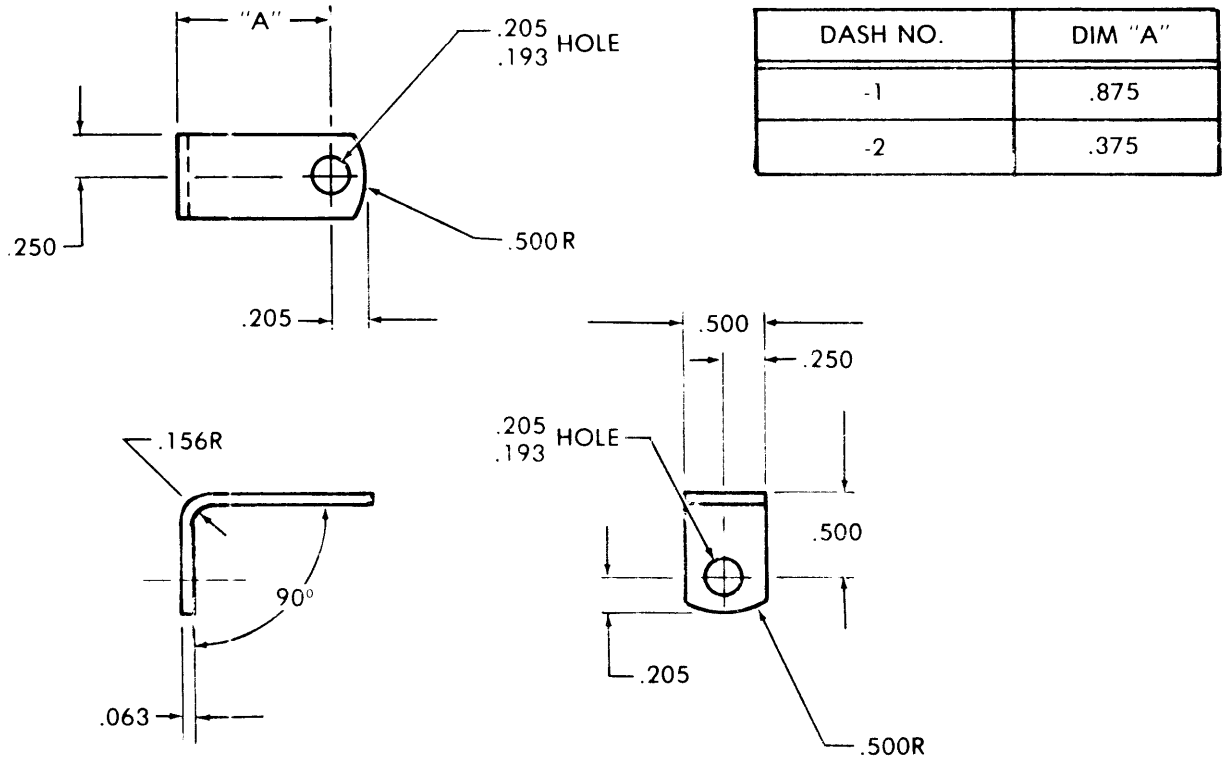
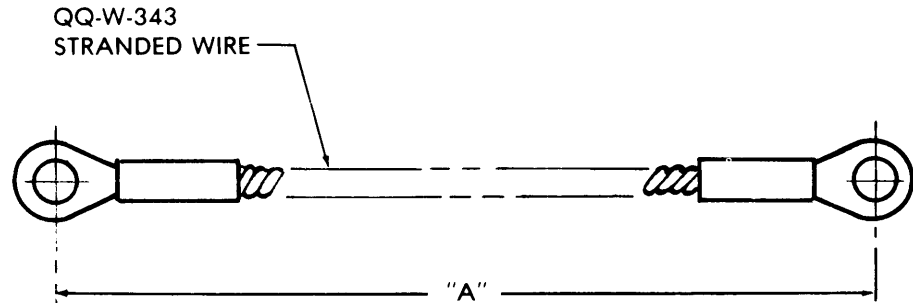


Figure D-390. Bracket, Angle PN ES-B-220311  
 Fabricate From: NSN 9535-00-232-0378  
 Material: .063 AL. Alloy 2024-T3 per QQ-A-250/5



DASH NO.	DIM "A"
1	4 ¼
2	6
3	5 ½
4	7 ½

Figure D-391. Cable Assy, Special Purpose, Electrical PN ES-B-220309  
 Fabricate From: NSN 6145-00-236-9503 and 5940-00-143-4794  
 Material: Wire, Tinned, Soft, Type RB Class M and Terminal, Lug, Crimp Style



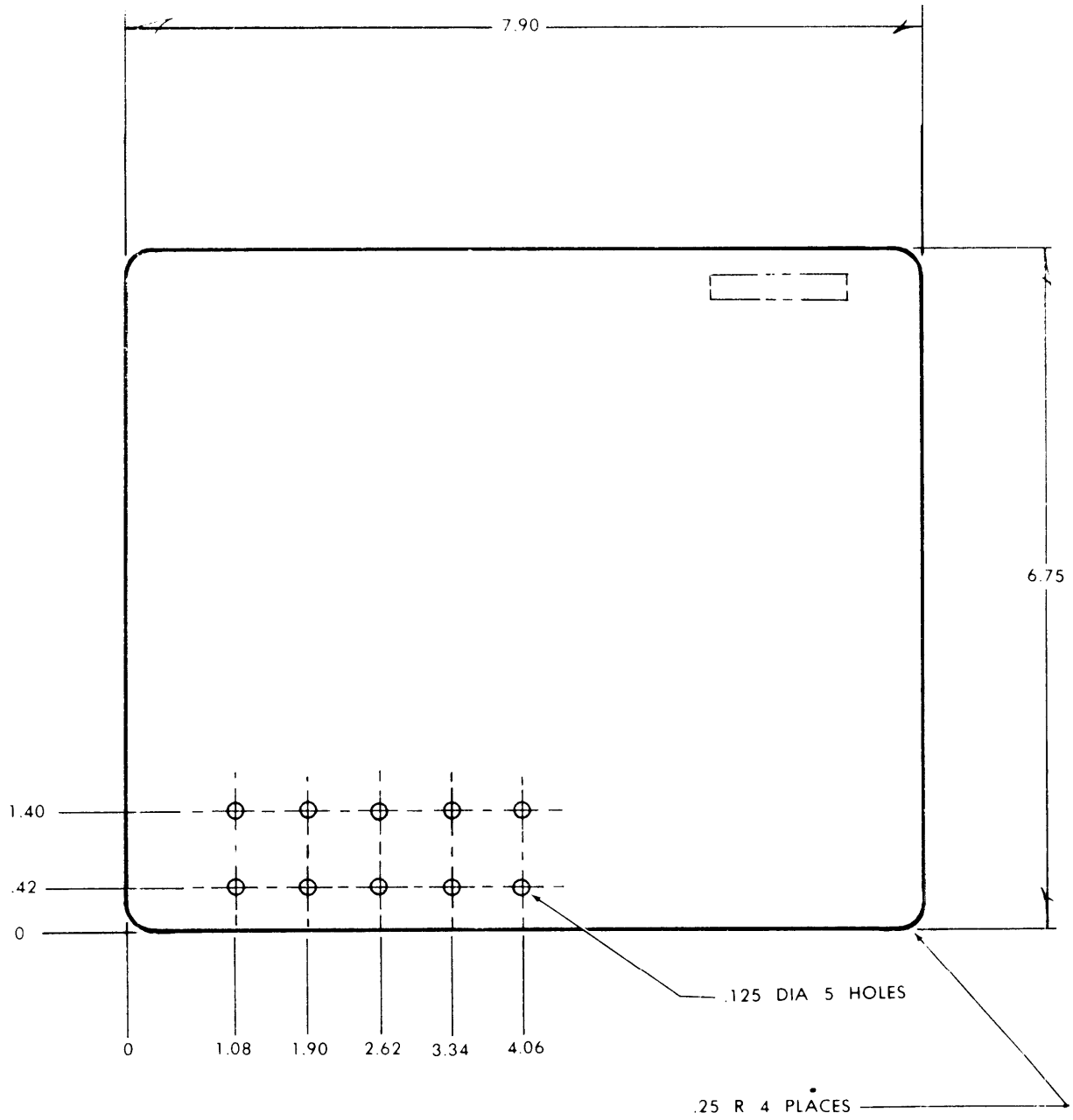


Figure D-392. Plate, Reinforcing, DF Ant., Rear PN 5065698  
Fabricate From: NSN 9535-00-232-1882  
Material: AL. Alloy, 6061-T6, .032 THK, QQ-A-250/11

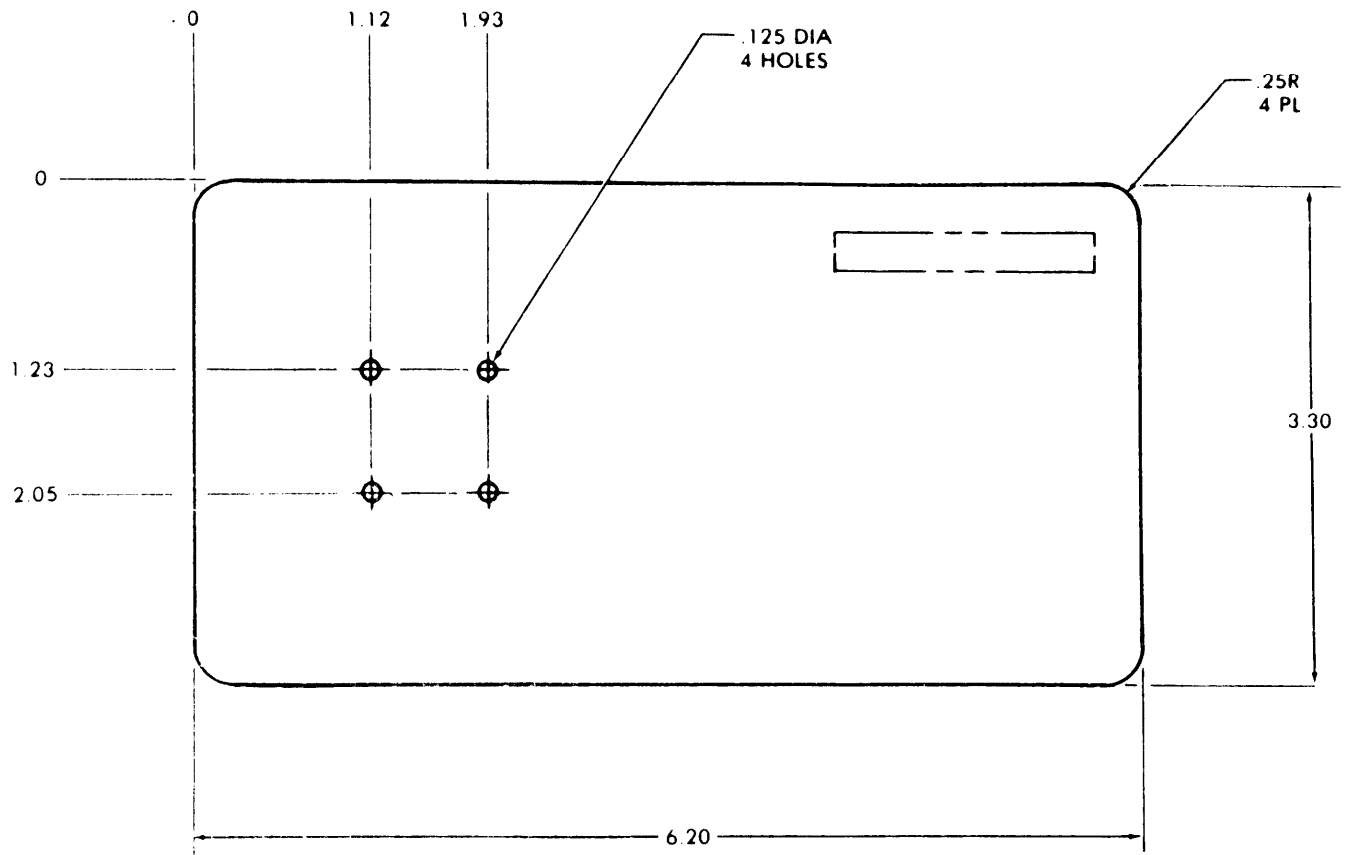
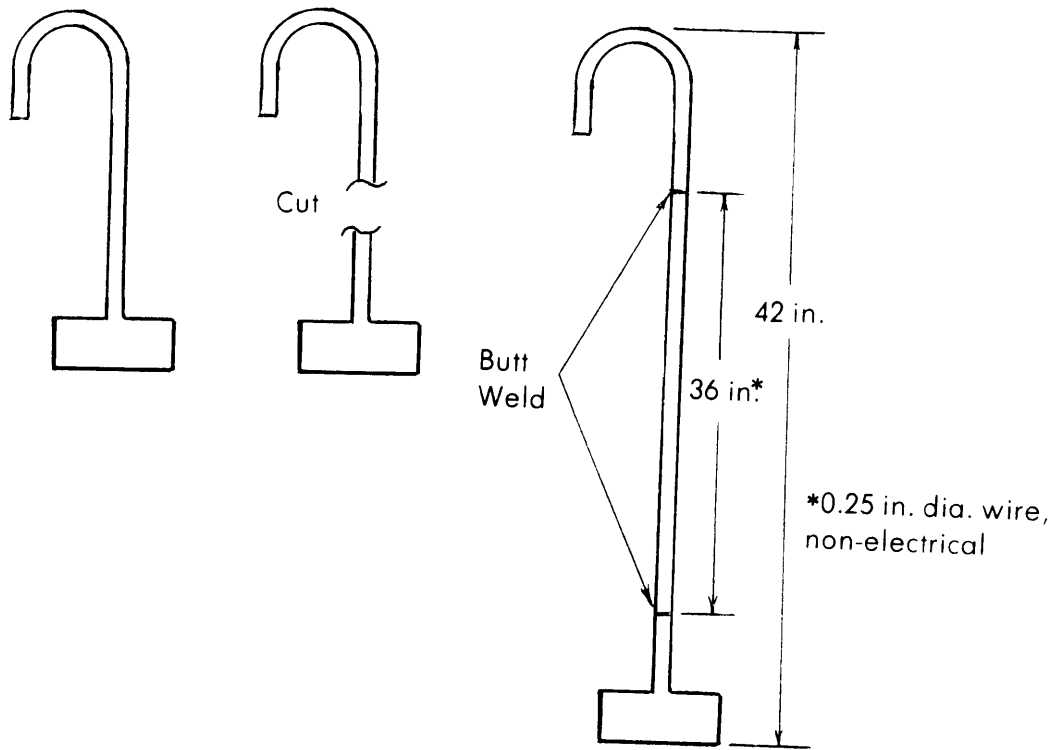


Figure D-393

Fabricate from:  
Material:

Plate, Doubler, Forward PN 5065696  
NSN 9535-00-084-4448  
AL Alloy, 6061-T6, .062 THK, QQ-Q-250/11

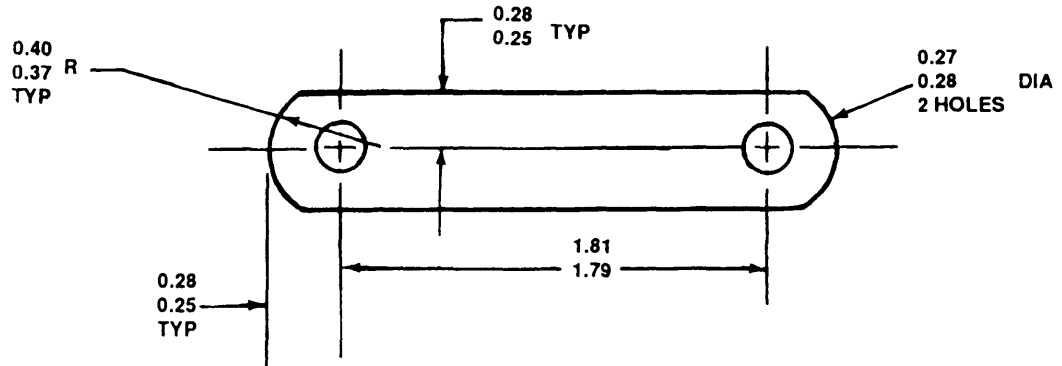


PART NUMBER: HM-1 FSCM: 81996

FABRICATE FROM: P/N SW1961-2, NSN 1730-00-427-7939

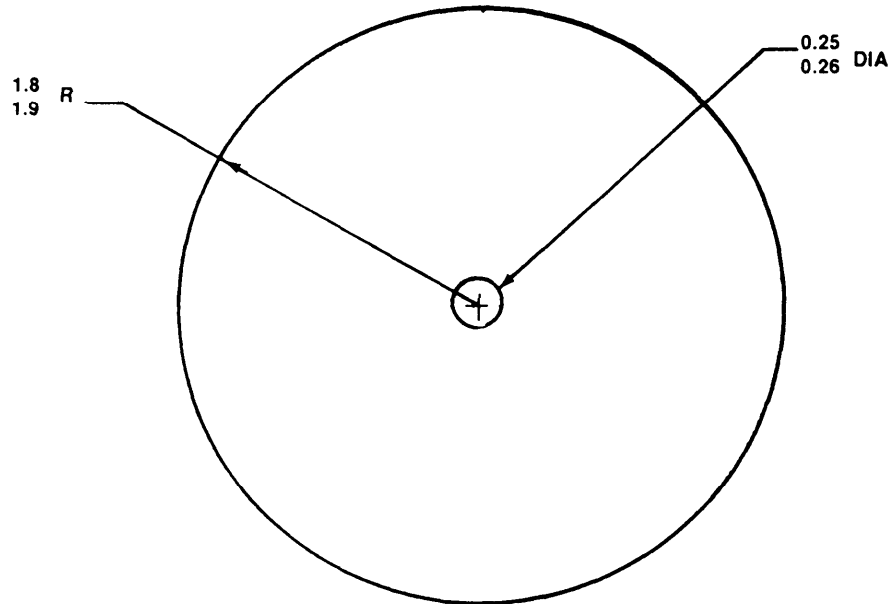
FABRICATION INSTRUCTIONS: CUT TIE-DOWN IN HALF. WELD 36 INCH PIECE OF 0.25 INCH DIAMETER WIRE, NONELECTRICAL, ANNEALED, P/N C120917, NSN 9525-00-167-1817 ON EACH HALF OF MAIN ROTOR BLADE TIE-DOWN.

FIGURE D-394 MAIN ROTOR BLADE TIE DOWN AFTER HUB SPRING INCORPORATION



PART NUMBER: GRHB-1  
FABRICATE FROM: GASKET MATERIAL, MIL-C-6183, 0.0157 OR 0.0313 INCH THICK, NSN 5330-00-054-1450

Figure D-395 Gasket GRHB-1.



PART NUMBER: GRHB-2  
FABRICATE FROM: GASKET MATERIAL, MIL-C-6183, 0.0157 OR 0.0313 INCH THICK, NSN 5330-00-054-1450

Figure D-396 Gasket GRHB-2.

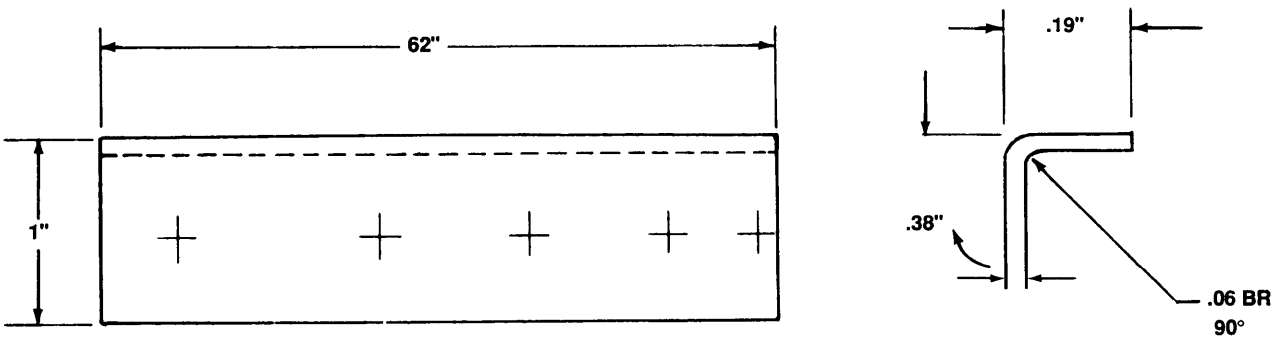


Figure D-397. Part Number 205-060-805-35 RETAINER 2 ea 62"  
 205-060-805-37 RETAINER 2 ea 17"  
 Fabricate from: NSN 9535-00-167-2267  
 Material: 2024 AL ALY, Federal Specification QQ-A-250/5, T3,  
 0.032 inch DIA.

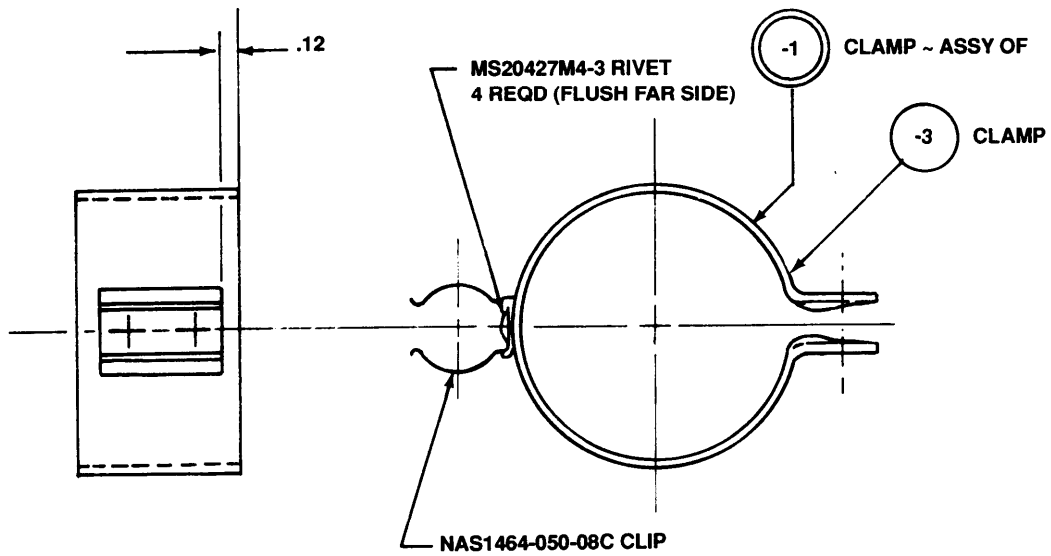


Figure D-398. Part Number 204-050-228-1 CLAMP ASSEMBLY, Support  
 Fabricate from: NSN 1560-00-691-0553

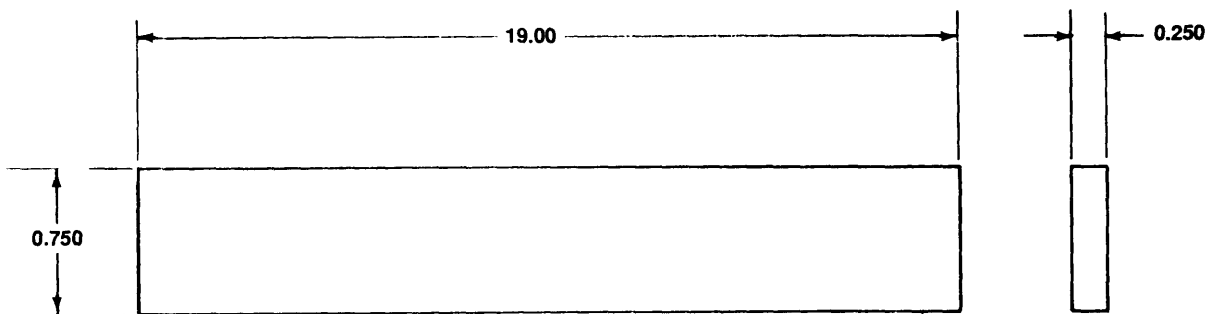


Figure D-399. Part Number 205-060-254-9 SEAL HINGE  
 Fabricate from: NSN 9330-00-939-7534  
 Material: STRIP PLASTIC, 0.250 X 0.750 x19.00

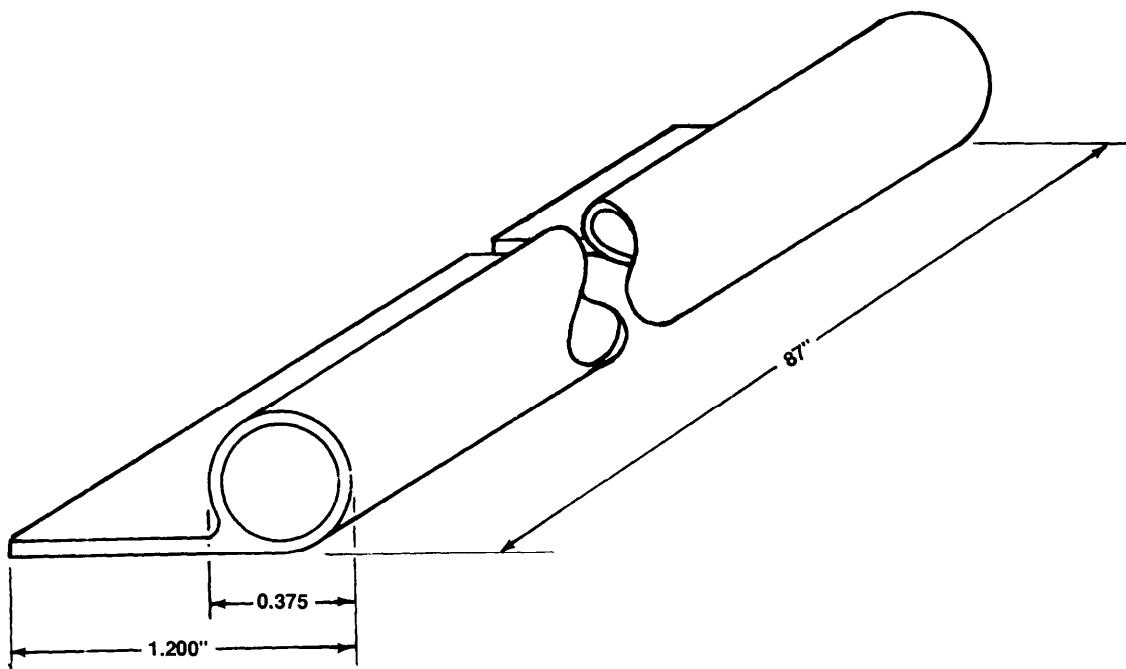


Figure D-400. Part Number 205-060-805-41 SEAL BULB  
 Fabricate from: NSN 9390-00-851-9178  
 Material: MIL SPEC: RL-2066

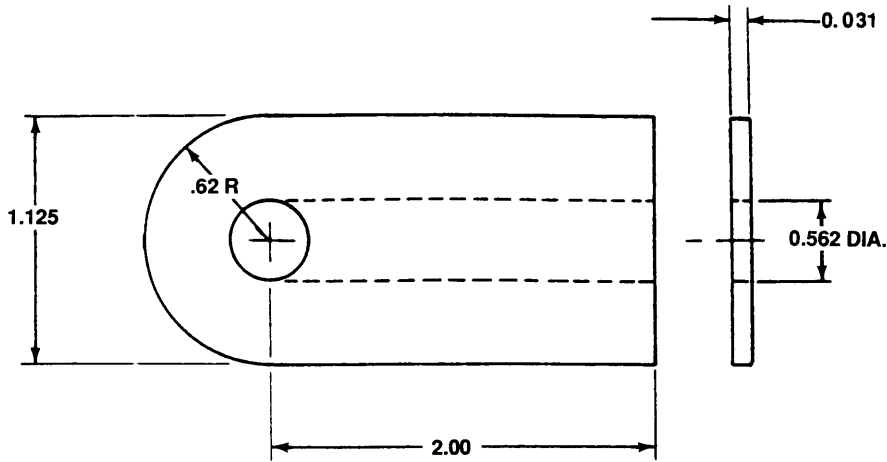


Figure D-401. Part Number: DK-1 , ANTI-CHAFFING PAD  
 Fabricate from: NSN 5970-00-912-1907  
 Material: MELAMIDE RESIN IMPREGNATED GLASS CLOTH  
 MIL-P-15037 .031 Thick

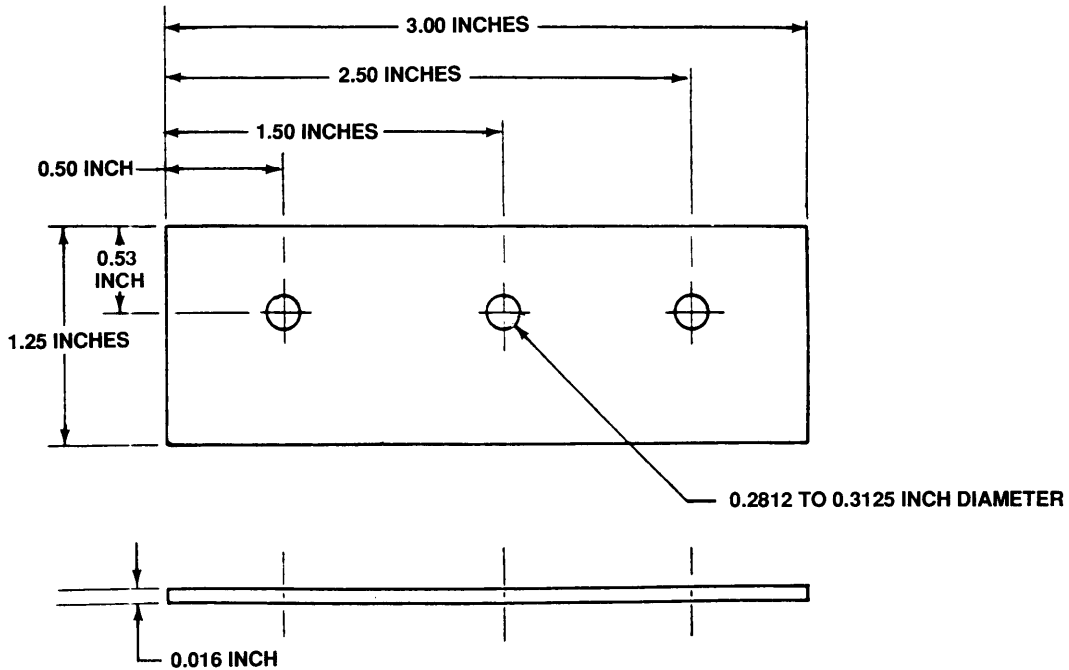


Figure D-402. Part Number 1560-UH1-981 SHIM  
 Fabricate from: NSN 9535-00-084-4450  
 Material: 2024T3 AL ALY

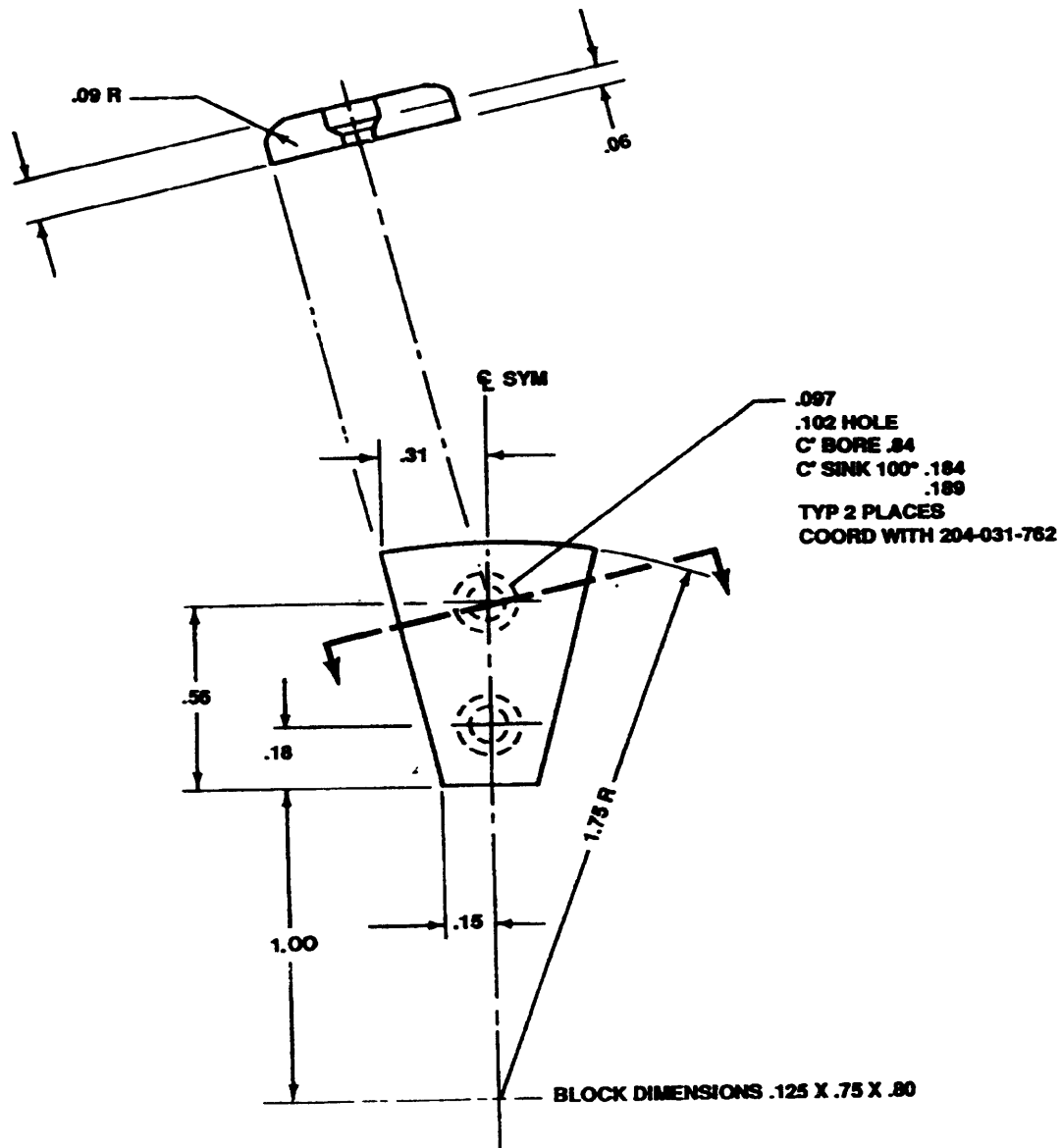


Figure D-403.

Part Number 204-031-766-1 DOOR STAY  
Fabricate from: NSN 9330-01-295-4343  
Material: TETRALON, 510, P/N 5T125X12.000E



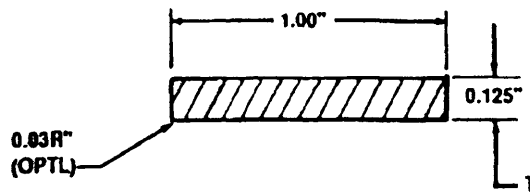


Figure D-404. Part Number: 205-030-872-21  
Fabricate from: NSN 9320-00-814-4583  
Material: MIL-R-6130 Extrusion Rubber,  
Solid Rectangular, Color Natural  
26.2 Inches long

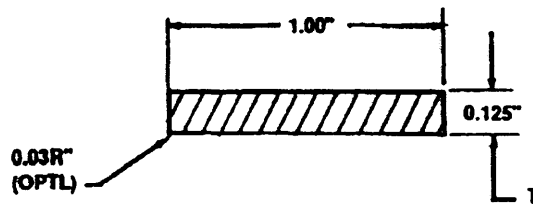


Figure D-405 Part Number 205-030-872-23  
Fabricate from: NSN 9320-00-814-4583  
Material: MIL-R-6130 Extrusion Rubber,  
Solid Rectangular, Color: Natural  
82.7 inches long

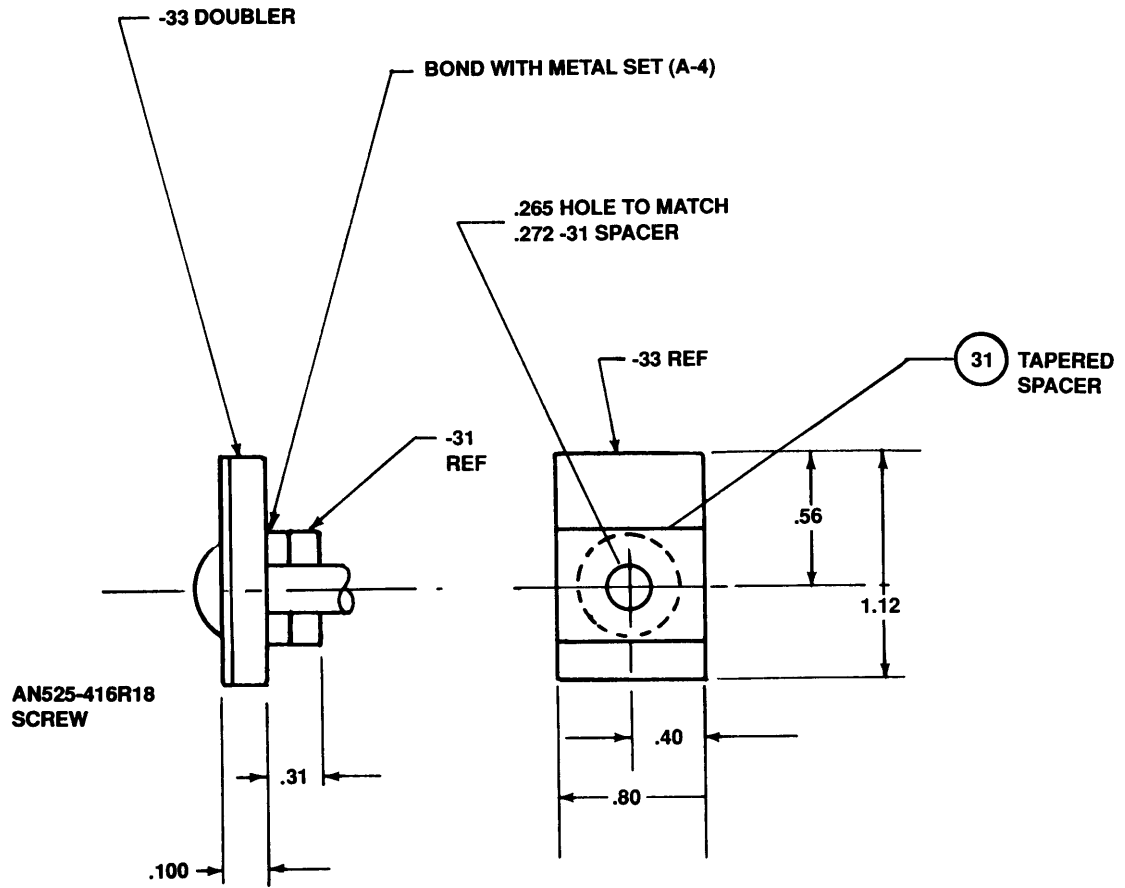
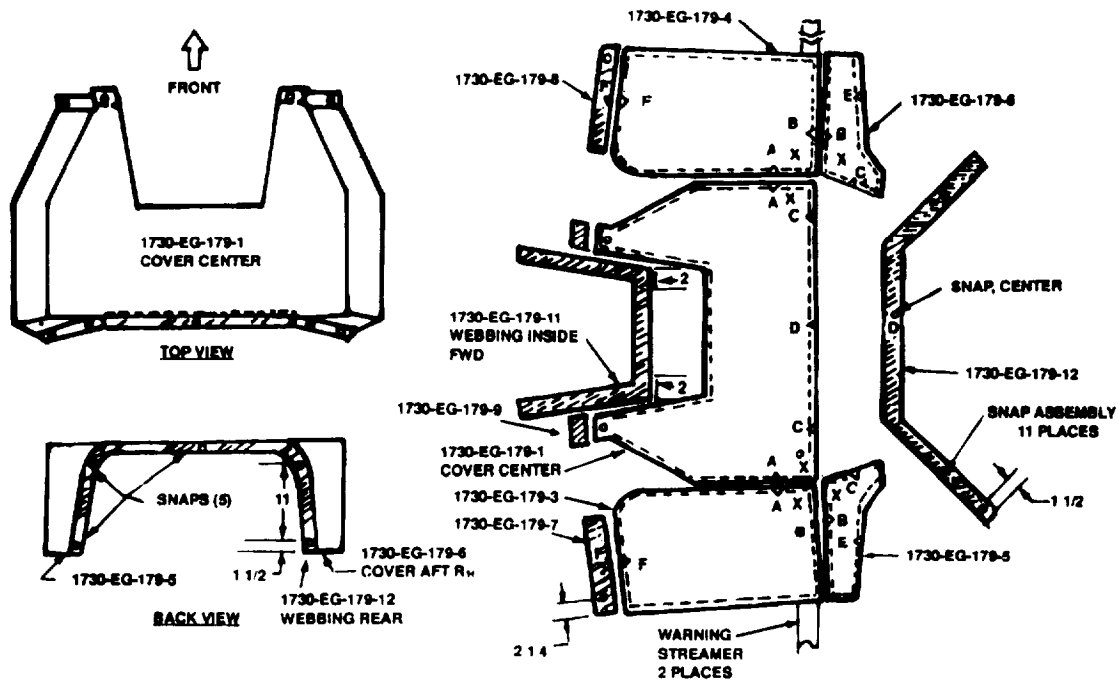


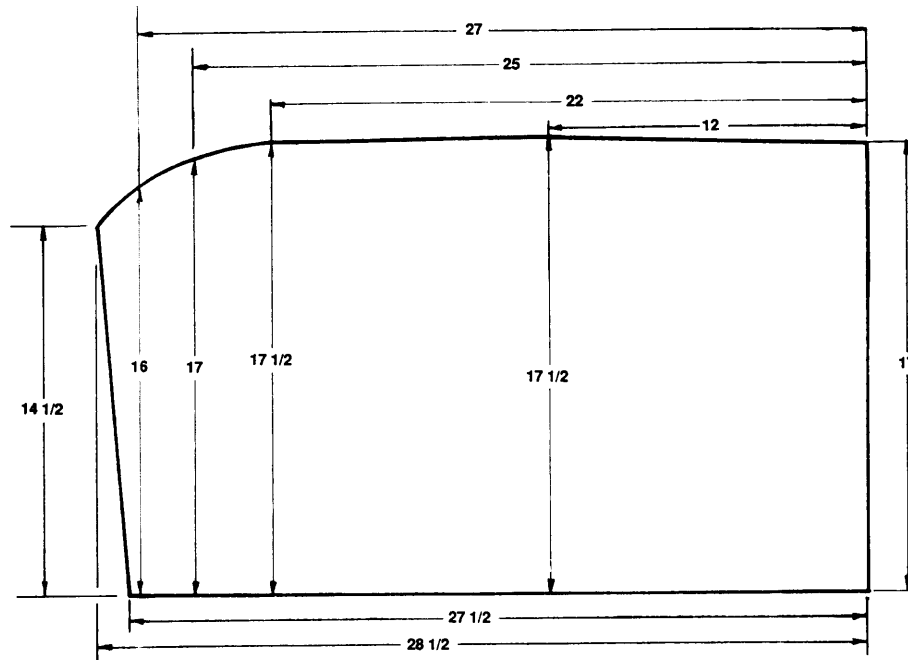
Figure D-406. Part Number  
Fabricate from:  
Material:

205-031-481-33, DOUBLER -.100 X 1.2 x 1.0  
9535-00-064-4430  
2024 AL ALY SHEET, Federal Specification, QQ-A-250/5,  
T3 .100 inch Thickness

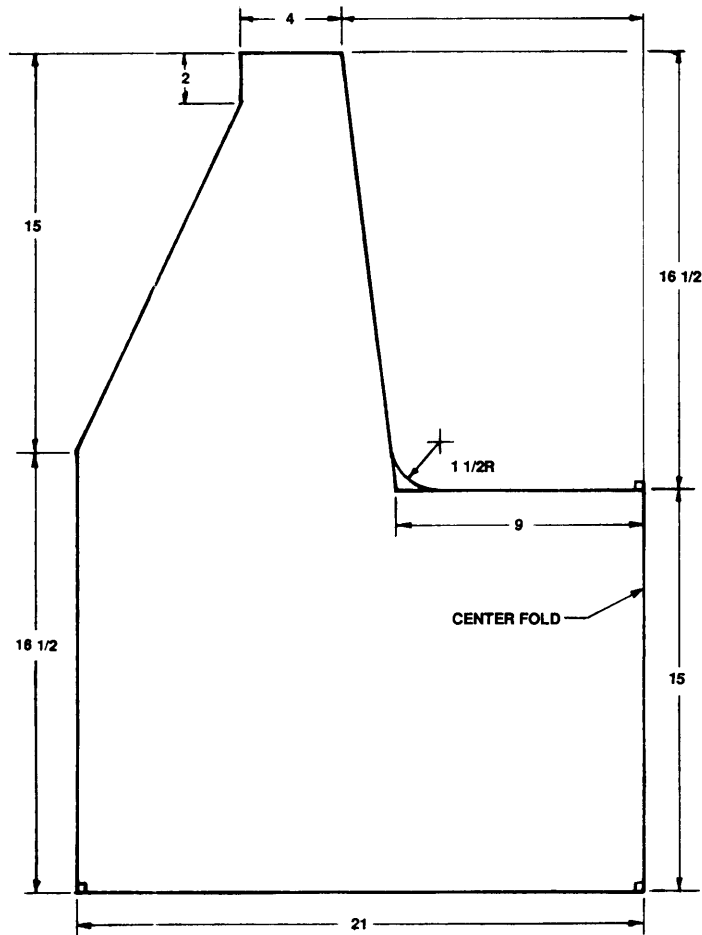


WEBBING REAR	1730-EG-179-12	2 X 65
WEBBING INSIDE FWD	1730-EG-179-11	2 X 40
WEBBING DOUBLER R/H	1730-EG-179-10	2 X 4
WEBBING DOUBLER L/H	1730-EG-179-9	2 X 4
WEBBING FWD R/H	1730-EG-179-8	2 X 15
WEBBING FWD L/H	1730-EG-179-7	2 X 15
COVER AFT R/H	1730-EG-179-6	19 X 9.29
COVER AFT L/H	1730-EG-179-5	19 X 9.25
COVER SIDE R/H	1730-EG-179-4	28.5 X 17.5
COVER SIDE L/H	1730-EG-179-3	28.5 X 17.5
COVER, CENTER	1730-EG-179-1	42 X 31.5
CLOTH, COATED	8305-00-820-8155	MIL-C-20696
THREAD, NYLON	8130-00-262-2772	VT 295
WEBBING NYLON	8305-00-082-2142	MIL-W-4098
STREAMER, WARNING	8345-00-863-9170	57034391-3
CAPSNAP, FASTENER	5325-00-359-6844	
SOCKET, SNAP FASTENER	5325-00-285-6250	

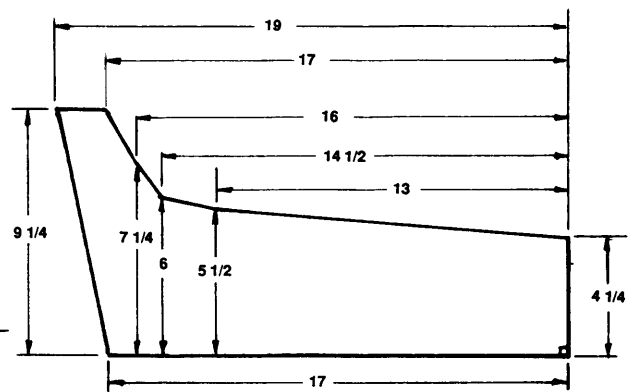
Figure D-407. cover Assembly P/N 1730-EG-179 (Sheet 1 of 2)



1730-EG-179-3 COVER SIDE L<sub>H</sub> (SHN)  
1730-EG-179-4 COVER SIDE R<sub>H</sub> (OPP)

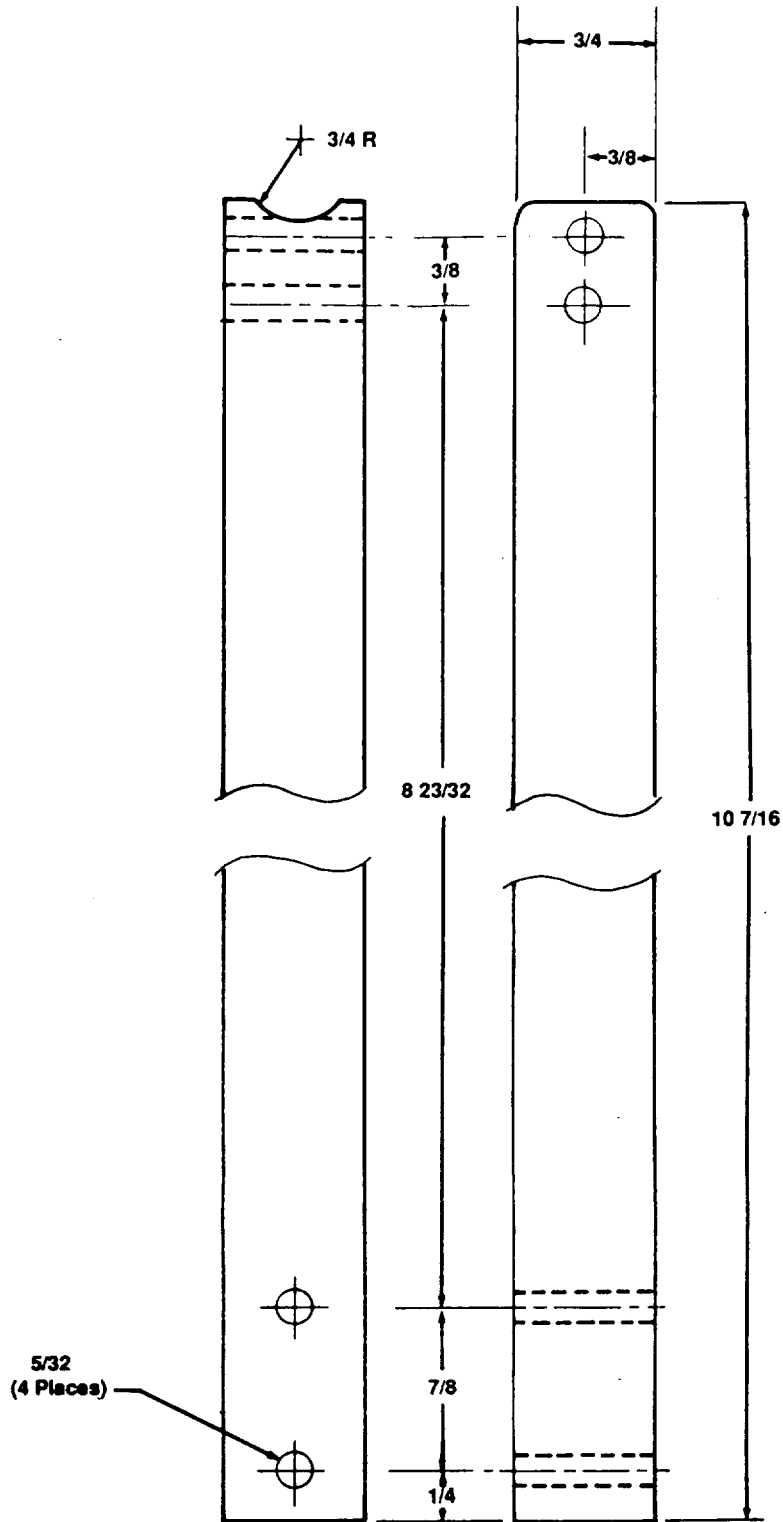


1730-EG-179-1 COVER CENTER  
PART IS SYMMETRICAL ABOUT CENTERFOLD  
L<sub>H</sub> DIMENSIONS (SHN)



1730-EG-179-5 COVER AFT L<sub>H</sub> (SHN)  
1730-EG-179-6 COVER AFT R<sub>H</sub> (OPP)

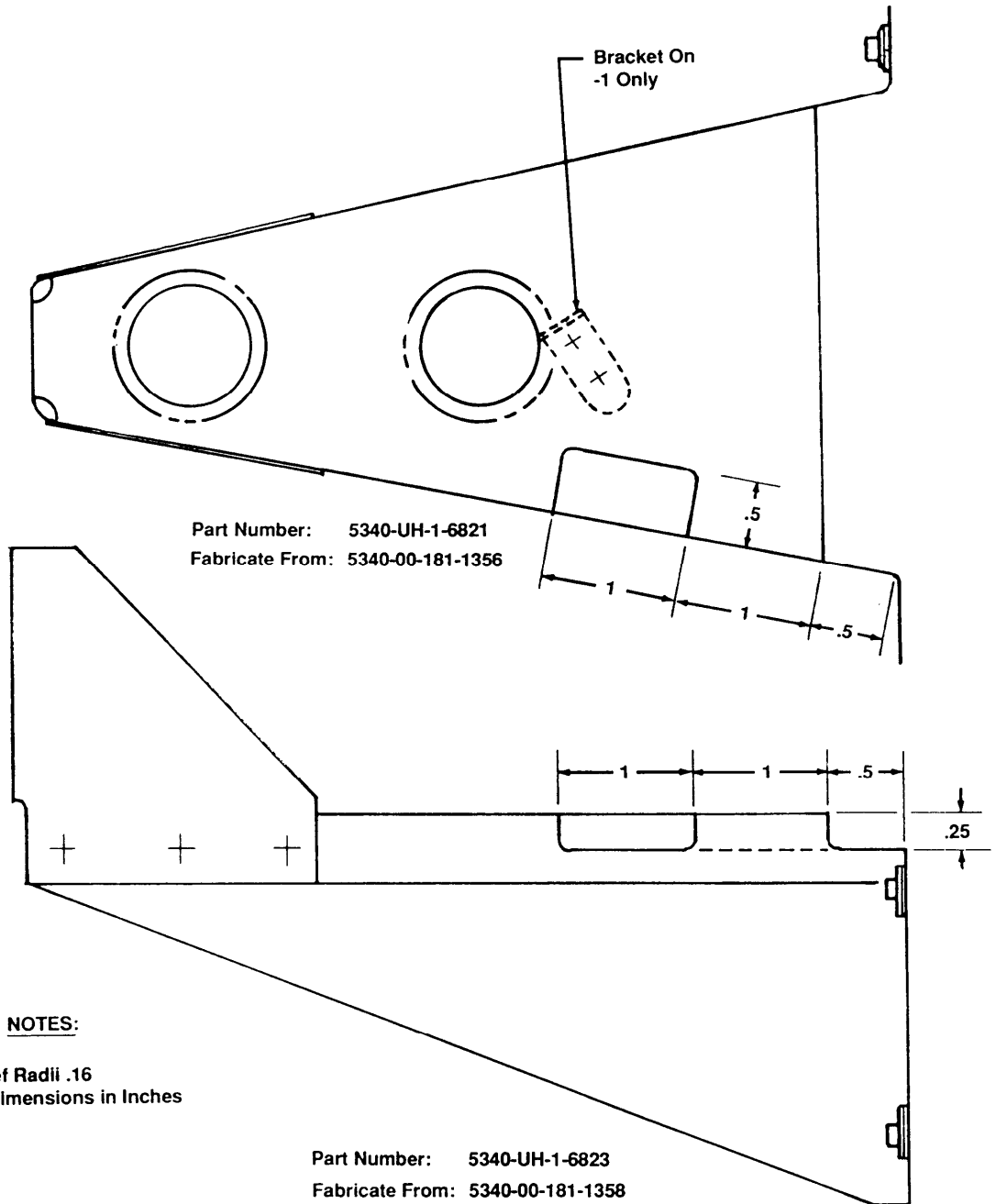
Figure D-407. Cover Assembly P/hi 1730-EG-1 79 (Sheet 2 of 2)



Part Number: BS-1, Troop Seat Support  
Material: 2024T3 Tube 0.065 inch Thick  
NSN: 4710-00-278-6381

Figure D-408

Fuel Quantity Transmitter Bracket  
P/N 205-062-682-1/-3



NOTES:

1. Relief Radii .16
2. All Dimensions in Inches

Figure D409

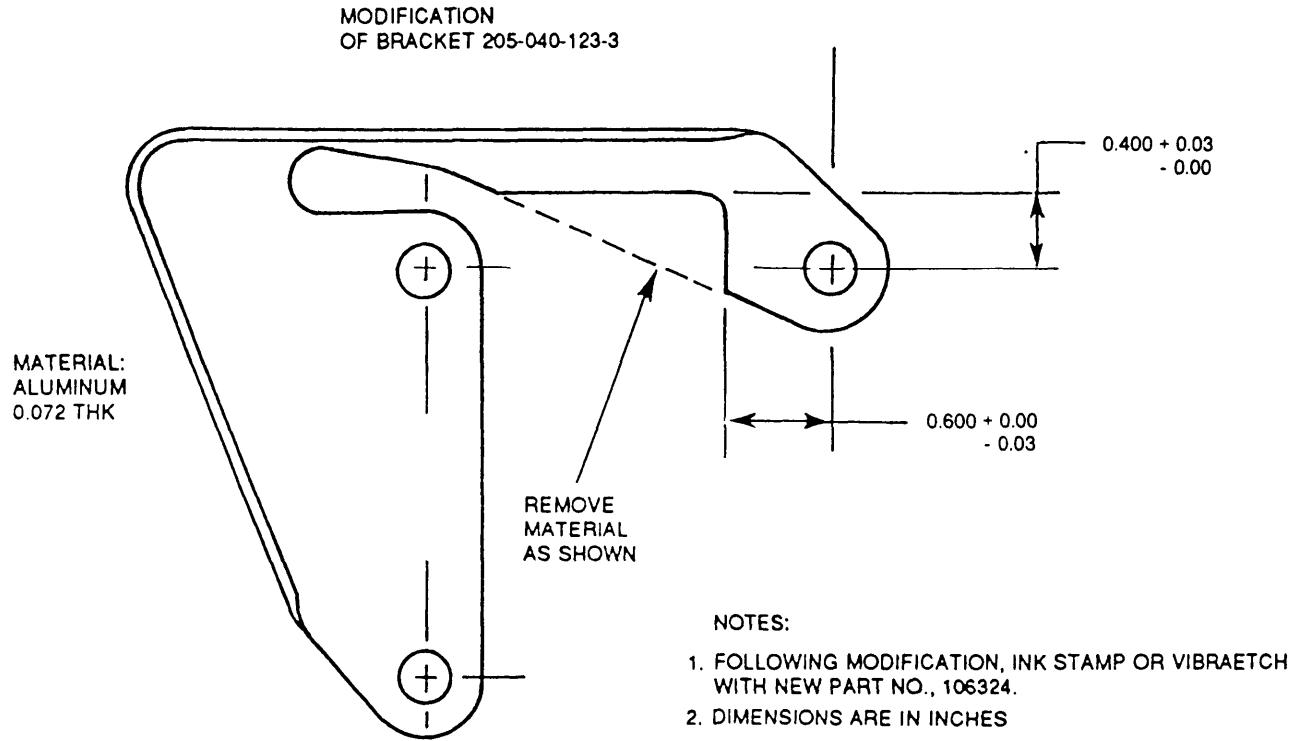
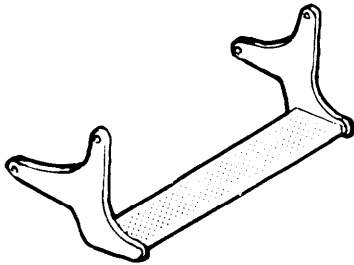


Figure D-410, Bracket 106324

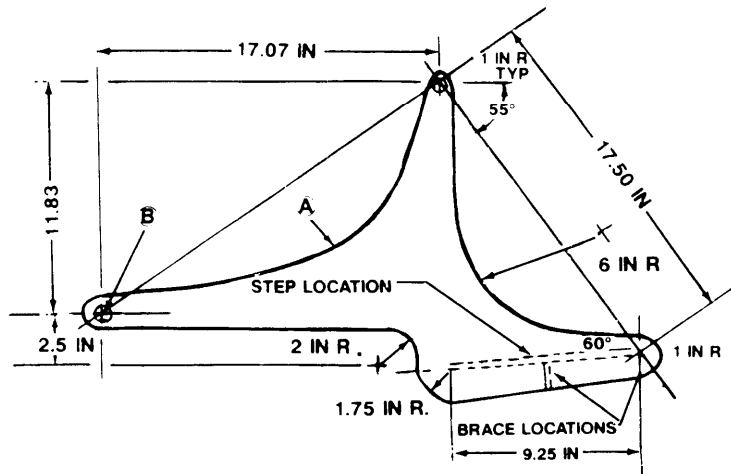
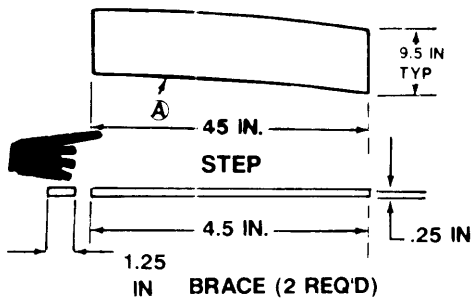
MATERIAL: PLATE ALUM, ALOY PER QQA-250/7  
 TEMPER H-32, THICKNESS .25 INCH, OR EQUIVALENT

NOTES:

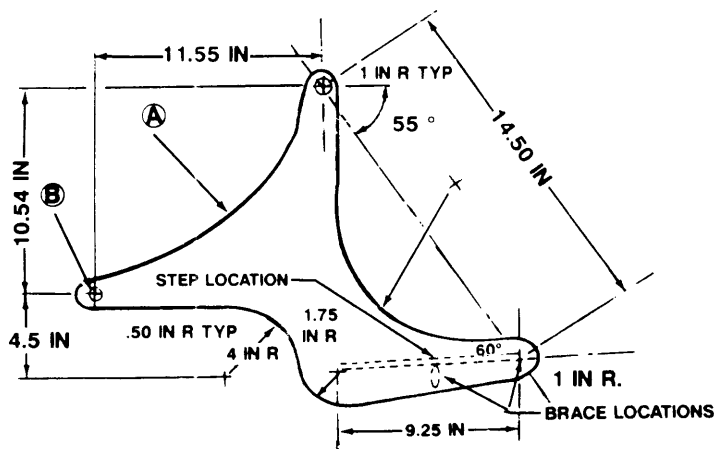
1. WELD PER MIL-STD-1595A BOTH SIDES OF STEP AND BRACE AS SHOWN.
2. FILE ALL EDGES TO REMOVE BURRS.
3. STAGGER WEIDS AT 3 INCH INTERVALS ON OPPOSITE SIDES OF BRACES .
- Ⓐ 4. CONTOUR TO MATCH AIRCRAFT.
5. FINISH: PAINT ALL SURFACES WITH PRIMER, MIL-P-23377 AND TOP COAT, MIL-C-46168 .
- Ⓑ 6. MATCH DRILL TO AIRCRAFT HARDPOINTS ( .25 IN ).
7. APPLY NON-SKID COATING TO TOP OF STEP PER MIL-W-5044, TYPE II, CLASS 2. PRIME STEP WITH MIL-P-23377 PRIOR TO APPLICATION.



PART NUMBER: STP-01  
 AIRCRAFT STEP ASSY.



FORWARD SUPPORT



AFT SUPPORT

Figure D-411



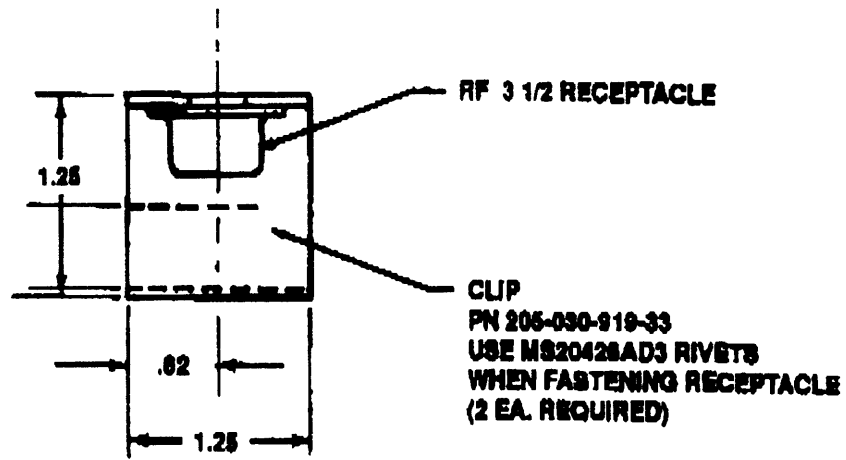


Figure D-412. Part Number: 205-030-919-33  
Fabricate from: NSN 9535-00-232-0378  
METAL SHEET, QQA 250-5  
GRZ404, T3  
0.063 INCH THICK

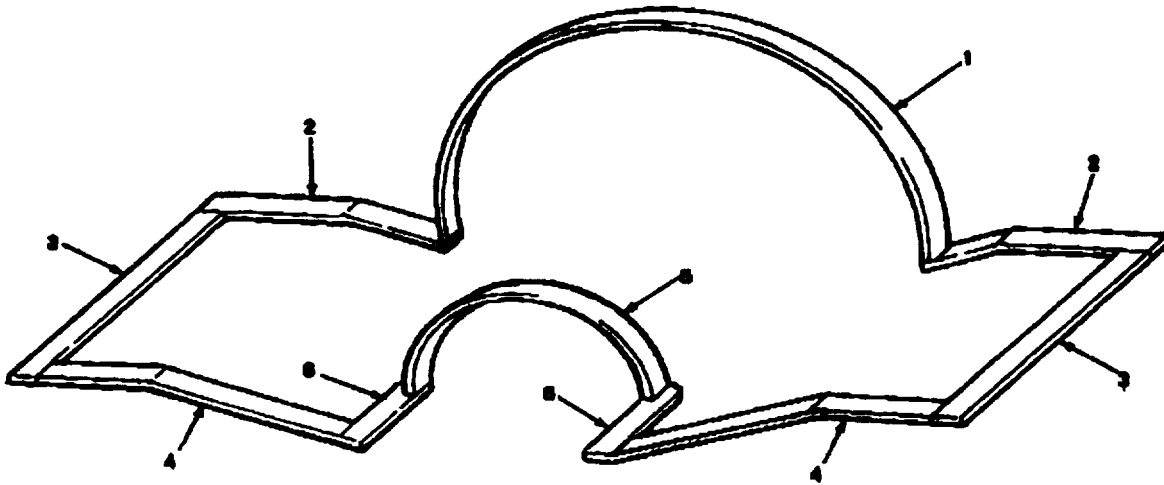
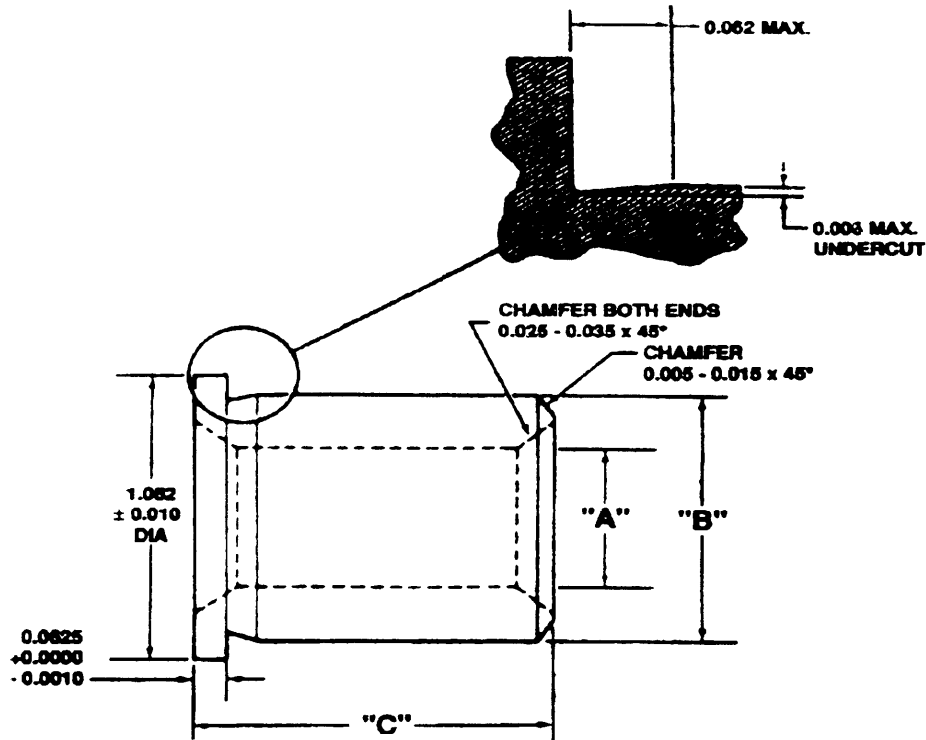


Fig. D-413

Gasket: PIN AA9500-2317-0  
 Manufactured from: 5330-01-330-2786  
 Dimensions. .50 ± .03 inch thick  
                   .75 ± .03 Inch wide  
 Lengths Item 1-35 5/8 inches  
               2-5 3/4 inches  
               3-11 3/4 inches  
               4 -12 1/2 inches  
               5 -14 3/8 inches  
               6-4 inches



BUSHING ITEM NO.	BUSHING PART NO.	SIZE	"A" DIA	"B" DIA OD	HOLE FOR BUSHING	"C" DIM (± 0.003)
-1	22-012-35-28-34	STD	0.559/0.556	0.7510-0.7515	0.7495-0.7505	0.437
-1	22-012-35-28-34	OS 0.005	0.559/0.556	0.7560-0.7565	0.7545-0.7555	0.437
-1	22-012-35-28-34	OS 0.010	0.559/0.556	0.7610-0.7615	0.7595-0.7605	0.437
-1	22-012-35-28-34	OS 0.015	0.559/0.556	0.7660-0.7665	0.7645-0.7655	0.437
-1	22-012-35-28-34	OS 0.030	0.559/0.556	0.7810-0.7815	0.7795-0.7805	0.437
-1	22-012-35-28-34	OS 0.060	0.559/0.556	0.8110-0.8115	0.8095-0.8105	0.437
-3	22-014-47-58-34	STD	0.747/0.744	0.8760-0.8765	0.8745-0.8755	0.906
-3	22-014-47-58-34	OS 0.005	0.747/0.744	0.8810-0.8815	0.8795-0.8805	0.906
-3	22-014-47-58-34	OS 0.010	0.747/0.744	0.8860-0.8865	0.8845-0.8855	0.906
-3	22-014-47-58-34	OS 0.015	0.747/0.744	0.8910-0.8915	0.8895-0.8905	0.906

NOTES:

1. "A" AND "B" DIAMETERS TO BE PARALLEL AND CONCENTRIC WITHIN .003 TIR.
- \*2. CADMIUM PLATE BUSHING PER QQ-P-416, TYPE II, CLASS 3.
3. ALL DIMENSIONS TO BE MET AFTER PLATING.
4. FINISH TO BE 32 RMS.
5. MARK BUSHINGS BY PART NO. AND SIZE.

\* ALTERNATE: USE MIL-P-23377, MIL-P-53030, OR MIL-P-53022

MATERIAL:

AISI 4140 ST L	MIL-S-5626 OR AMS 6381, 6390
AISI 8740 ST L	MIL-S-6049 OR AMS 6323
AISI 8630 ST L	MIL-S-6050 OR MIL-T-6732
AISI 4130 ST L	MIL-S-5758 OR MIL-T-6736

HEAT TREAT:

PER MIL-H-6875 TO ROCKWELL C-26 TO C-33, WITH TENSILE STRENGTH OF 125,000 - 145,000 PSI.

Figure D-414. Replacement of lift link bushings

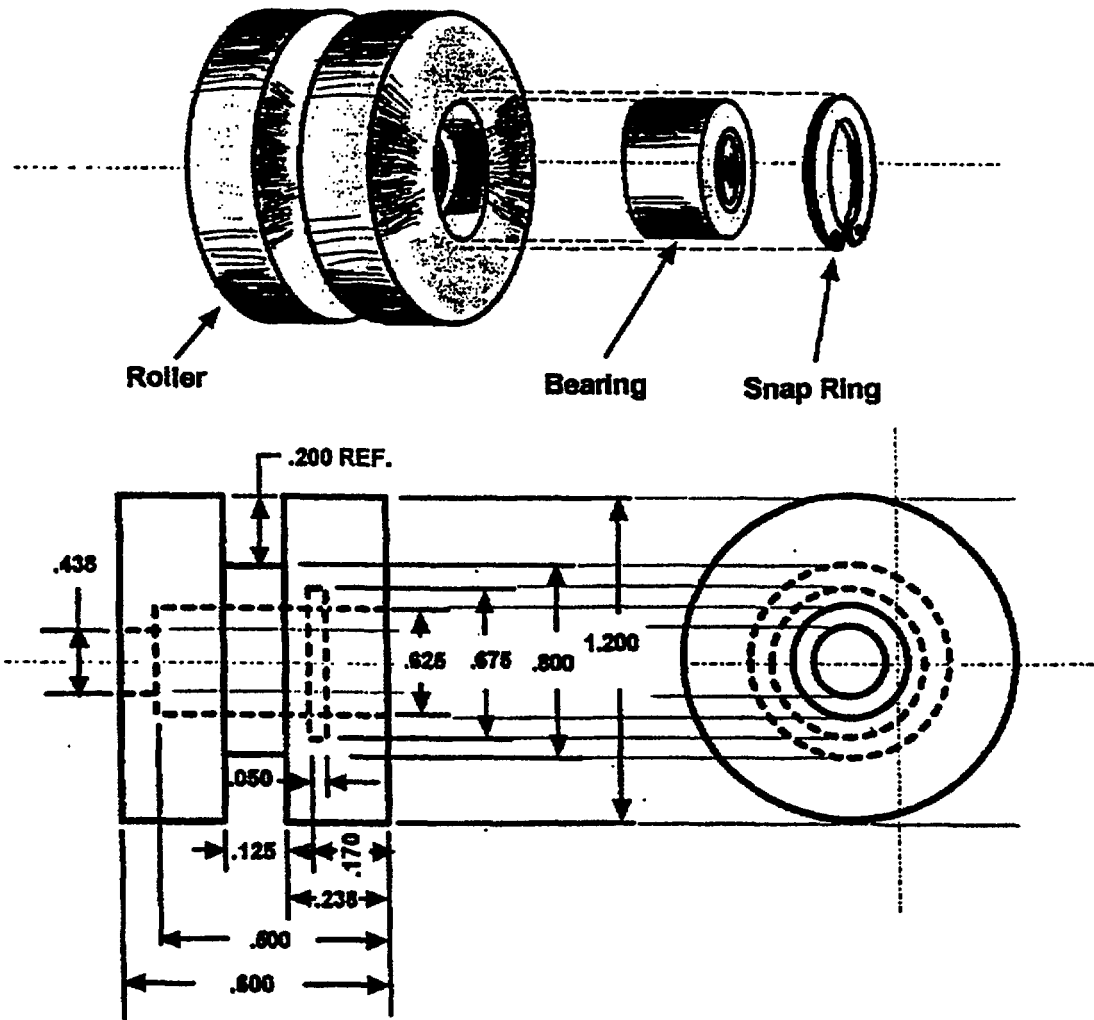


Fig. D-415. DOOR ROLLER, P/N SKRV2-1994

FABRICATE FROM: NSN 9390-01-020-9953  
 MATERIAL: Nylon  
 BEARING: PIN MS14102-4  
 LOCK RING: P/N MS16625-1062

## APPENDIX E

### STORAGE OF AIRCRAFT

#### SECTION 1. GENERAL INFORMATION

##### E-1 . PURPOSE.

###### NOTE

Aircraft that are inactive for seven or more consecutive days must be placed in storage. Scheduling helicopters for flight or ground run a minimum of once every seven days is key to long term preservation of mission ready aircraft. If this is not possible the aircraft should be processed into the appropriate category of storage.

The purpose of this chapter is to assure the readiness of inactive aircraft (not flown or ground run for seven or more consecutive days) by processing for storage. The objective is to minimize airframe and component corrosion, seal and packing deterioration and maintain avionics and electrical equipment in an operable condition. Procedures provided are for aircraft in storage for six months or less, inspection requirements during storage and procedures to activate the aircraft after storage.

a. Flyable Storage (no time limit). This implies maintaining the helicopter in operable condition and will entail mooring helicopter, installing protective covers, and a daily inspection every seven day, and an engine runup every fourteen days.

b. Short Term Storage (1-45 days). This type storage includes a ground runup, preservation of the engine fuel system, oil system, and exposed helicopter components together with removal of classified communications equipment battery, clock fire extinguishers, and first aid kit. The helicopter will be moored, protective covers will be installed, and a daily inspection will be performed every seven days.

c. Intermediate Storage (46-180 days). This category of storage will include all requirements of Short Term Storage. In addition, the fuel system will be preserved and a corrosion control program established.

d. Storage of Aircraft Undergoing Maintenance (no time limit). This category of maintenance will include general requirements of storage of aircraft undergoing any maintenance action which causes the aircraft to be inactive for more than seven days. Due to the wide range of maintenance actions that may create this situation, some storage procedures will not be required and a degree of latitude is given to the local maintenance officer on the storage measures needed for the particular situation. The seven day limit is a guideline and variances are allowed at the discretion of the maintenance officer.

##### E-2. STORAGE RESPONSIBILITY.

The local maintenance officer shall be responsible for processing the helicopter 'for storage taking into consideration the anticipated duration of storage and local climatic conditions.

a. Records. The processing organization shall be responsible for performing a receiving check of the helicopter and for the records-keeping requirements during storage. For forms used for equipment inventory refer to DA PAM 738-751 Army Maintenance Management System.

b. Removed Equipment. Equipment and components removed from the helicopter as part of storage procedures shall be stored and records maintained in accordance with current supply directives.

###### NOTE

Any component removed because of accident or materiel failure shall not be preserved but shall be shipped in the present condition.

c. Classified Equipment. Removal of classified equipment other than communications equipment shall be discretionary with the Commanding Officer. His decision will be based on consideration of local storage facilities, climatic conditions affecting deterioration or corrosion, and man-hours required to remove and reinstall such equipment. Appropriate security measures shall be taken for all classified equipment either removed or left installed.

E-3. INSPECTION OF STORED HELICOPTERS.

Aviation unit maintenance officer shall be responsible for establishing an inspection program to ensure that the helicopter remains properly preserved. Helicopters in Flyable Storage will have a daily inspection at least once every seven days and an engine runup at least once every 14 days. Helicopters in Short Term or Intermediate Storage shall be inspected for corrosion every 15 days where relative humidity exceeds 40%. Helicopters in any storage shall be

inspected for condition of protective coverings whenever they have experienced high winds (exceeding 40 mph). In addition, the following general inspection procedures apply to all types of storage:

- a. Provide adequate helicopter ventilation and preservation. Determine cockpit temperatures by thermometer, and when in excess of 135°F (57°C), ventilate to prevent condensation and mildew.

b. Check that all fuselage, wings, center section, control surfaces, and empennage drain holes are open.

c. If covers are used, check that they are not accumulating water. provide drains if necessary. Replace damaged or deteriorated covers.

d. Regularly inspect and treat for corrosion as necessary. Inspection frequency will be determined by local humidity conditions. Close attention should be given to areas where moisture does not evaporate readily. Evidence of corrosion will not be as obvious on painted surfaces as it is on bare metal; however, corrosion can attack metal through paint and will be indicated by blisters or scaly appearance of paint.

e. Inspect static ground wires, tie-down straps and mooring devices (rope, cables, rods, or eyes) at regular intervals but immediately after being subjected to winds exceeding 40 mph. Replace deformed or deteriorated ground wires or mooring devices and tiedown straps.

f. Inspect communications equipment for fungus and corrosion. At the first indication of deterioration, remove, clean, preserve, and package any affected components to comply with MIL-P-116. Stow these items in the helicopter from which removed.

g. Enter inspection date in the helicopter Log Book.

## SECTION II. FLYABLE STORAGE

### E-4. INSPECTION PRIOR TO FLYABLE STORAGE.

Helicopters in this storage category shall be maintained in a serviceable condition. Perform Daily Inspection (PMD cards) prior to accomplishing the requirements of subsequent paragraphs. Enter the date and type storage in the helicopter log book.

#### NOTE

The general requirements in Section I are applicable.

### E-5. PRESERVATION.

#### a. Power-train.

(1) Check the power-train lubrication system including sight gages. Service the system in accordance with Chapter 1.

(2) The preservation run up prescribed in paragraph E-5b completes the preservation of transmission and gearboxes.

#### b. Engine.



Cleaning materials are flammable and toxic. Avoid skin contact and breathing of solvent vapors.

#### NOTE

This runup may be omitted if the helicopter has been operated within the past fourteen days and is known to be dry.

(3) Limit the run to that necessary to stabilize engine temperatures.

(4) Shutdown engine in accordance with the Operator's Manual.

(5) After engine cools, install engine inlet and exhaust protective covers. If these are not available, seal the openings with barrier material (C115) and secure with tape (C279).

(6) Cover additional engine cowling openings as in step (5) above.

(7) Record in the helicopter log book the date helicopter was placed in Flyable Storage.

c. **Hydraulic System.** Check the hydraulic reservoir and fill as necessary with hydraulic fluid (C131).

d. **Fuel System.** Service fuel tanks to normal capacity after each engine runup. Drain water from fuel tanks before adding fuel.

#### NOTE

**Full tanks minimize fuel contamination by condensation. The maintenance officer shall determine the interval of periodic drainage.**

e. **Battery.**

(1) Check that all cockpit switches are OFF.

(2) Clean the battery as necessary, but leave it in the helicopter unless the temperature is expected to be colder than -40 degrees F (-40 degrees C).

(3) Service the battery in accordance with TM 11-6140-203-14-2.

f. **Airframe.**

(1) Install pitot tube cover or wrap pitot tube with barrier material (C115) and secure with tape (C279).

(2) Disengage circuit breakers.

(3) Close all doors and windows.

(4) Install static ground wire.

(5) install helicopter shipping and storage cover (flyable configuration), if available, in accordance with instructions accompanying covers.

#### E-6. MAINTENANCE OF PRESERVATION DURING FLYABLE STORAGE.

a. Helicopter shall be inspected in accordance with local directives and requirements in preceding paragraph E-3.

b. A preventive daily inspection in accordance with PMD cards will be performed at least every seven days, together with an engine runup in accordance with paragraph E-5b will be performed at least every fourteen days.

#### E-7. DEPRESERVATION AFTER FLYABLE STORAGE.

a. Remove protective covers, clean, and return to storage.

#### WARNING

**Cleaning materials are flammable and toxic. Avoid skin contact and breathing of solvent vapors.**

b. Remove all barrier material and tape. Remove tape residue with solvent, (C261).

c. Clean helicopter as necessary in accordance with Chapter 1.

d. Open all doors and windows for ventilation.

e. Remove ail tiedowns.

f. Perform preventive maintenance daily inspections in accordance with PMD cards.

g. Remove and stow static ground wire.

h. indicate on helicopter maintenance records that it has been depreserved and removed from storage.

### SECTION III. SHORT TERM STORAGE

#### E-8. INSPECTION PRIOR TO STORAGE.

#### NOTE

**The general requirements of Section I are a part of these procedures.**

a. Ensure that all removed components are preserved and stowed within the helicopter in suitable containers.

b. Record all removed or disconnected parts in the helicopter maintenance records.



**WARNING**

**Cleaning materials are flammable and toxic. Avoid skin contact and breathing of solvent vapors.**

c. Bolts, washers, nuts, and other hardware which are removed during disassembly should be coated with a light coat of corrosion preventive compound (C86), and reinstalled as removed from the major component unless otherwise specified.

d. Check fuel, oil, and hydraulic lines/hoses for leakage.

e. Lubricate the helicopter for the 50 hour interval in accordance with Chapter 1.

f. Record the date and type of storage in the helicopter records.

**E-9. PRESERVATION.**

a. Power-train.

**WARNING**

**Cleaning materials are flammable and toxic. Avoid skin contact and breathing of solvent vapors.**

(1) Clean the exposed bare metal surfaces with a clean cloth dampened with solvent (C261 ) and coat with corrosion preventive compound (C86).

(2) Deleted.

(3) Check power-train lubrication levels including sight gages and service in accordance with Chapter 1.

(4) Deleted.

(5) Deleted.

(6) If engine is inoperable, preserve power-train as follows:

(a) Remove main rotor blades in accordance with Chapter 5.

(b) Remove mast assembly in accordance with Chapter 6.

(c) Spray inside of transmission through top opening with one gallon of oil (C166 or C168). While spraying, manually rotate internal gears and bearings with input drive quills.

(d) Reinstall mast assembly in accordance with Chapter 6.

**WARNING**

**Cleaning materials are flammable and toxic. Avoid skin contact and breathing of solvent vapors.**

(e) Apply fingerprint remover (C88) to all unpainted surfaces of mast assembly. Remove residue with solvent (C261 ) on a clean cloth.

(f) Apply corrosion preventive compound (C86) to all unpainted surfaces.

(g) Reinstall main rotor in accordance with Chapter 5.

(h) Ensure 42 and 90 degree gear-boxes have been filled with oper-

sting oil (C166 or C168) to the proper operating level.

(7) Cover breather holes in gearboxes and transmission with barrier material (C115) and secure with tape (C279).

b. Engine. (Operable).

**WARNING**

Cleaning materials are flammable and toxic. Avoid skin contact and breathing of solvent vapors.



(1) Use every precaution to keep engine and its accessories clean. Keep air intake screens, plenum chambers, and compressor inlet screens clean and free of foreign material. Use solvent (C261 ) for general cleanup.

**WARNING**

**Cleaning materials are flammable and toxic. Avoid skin contact and breathing of solvent vapors.**

(2) Check oil level; service as required in accordance with Chapter 1. Remove any spilled oil on painted surfaces with a clean cloth dampened with solvent (C261 ).

**CAUTION**

**To prevent accidental firing of the engine ensure IGNITION SYSTEM IGNITER SOLENOID circuit breaker is open. (Pulled out.)**

(3) Disengage ignition system igniter solenoid circuit breaker.

**WARNING**

**Cleaning materials are flammable and toxic. Avoid skin contact and breathing of solvent vapors.**

(4) Remove fuel inlet and pump discharge strainers from fuel control. Clean with solvent (C261 ) and reinstall. Replace servo supply filter.

(5) Disconnect main fuel hose from main fuel manifold and starting fuel hose from starting fuel solenoid valve on T53-L-11 series engines.

(6) Disconnect main fuel hose from flow-diver assembly and starting fuel hose from starting fuel solenoid valve on T53-L-13 engines.

(7) Install temporary lines on ends of hoses to allow drainage into a suitable container.

(8) Connect hose from source of oil (C192) to fuel control inlet fitting.

(9) When engine has cooled sufficiently to prevent auto-ignition, set throttle to IDLE position.

**CAUTION**

**Do not operate starter beyond operating limits, three runs of 40 seconds each during any 60 minute period. A cooling interval of three minutes is required between each 40-second run. Do not engage starter until engine has stopped rotating. START FUEL switch, if installed, shall be ON. Ignition switch shall be ON.**

(10) Motor engine with starter to pump lubricating oil into fuel system.

(11) Open and close throttle to ensure flushing the fuel control.

(12) Continue motoring engine until fuel-free oil flows into container.

(13) Disconnect lubricating oil source from fuel system.

(14) Connect main and starting fuel hoses.

(15) Spray power turbine rotor with sufficient corrosion preventive compound to cover blades.

(16) Turn ignition switch OFF.

**NOTE**

**Use dehydrated air for spraying operations.**

(17) Install engine inlet and exhaust covers. If not available, seal openings with barrier material (C115) and secure with tape (C279).

(18) Remove, disassemble, and clean oil filter. Immerse filters in operating lubricant (C192), assemble, and install.

(19) Attach tag to fuel control stating, ENGINE PRESERVED; FUEL CONTROL PRESERVED WITH MIL-L-6081 OIL. FLUSH WITH OPERATING FUEL BEFORE PLACING IN SERVICE.

(20) Visually check entire engine to ensure:

(a) All holes are plugged.

(b) All ports are capped.

(c) All external parts are complete and secure.

(d) All bare metal, including internal and external threads, is covered with corrosion-preventive compound (C86).

(21) Deleted.

(22) Record date and extent of engine preservation in helicopter records.

c. **Engine (Inoperable).**

**WARNING**

**Cleaning materials are flammable and toxic. Avoid skin contact and breathing of solvent vapors.**

NOTE

**Engine involved in an accident shall not be preserved. Refer to TM 55-2840-229-23.**

(1) Use every precaution to keep engine and its accessories clean. Keep air intake screens, plenum chambers, and compressor inlet screens clean and free of foreign material. Use solvent (C261 ) for general cleaning.

**CAUTION**

**To prevent accidental firing of the engine, ensure IGNITION SYSTEM IGNITER SOLENOID circuit breaker is open. (Pulled out.)**

(2) Disengage ignition system igniter solenoid circuit breaker.

(3) Disconnect the fuel lines from the fuel control inlet and outlet ports.

(4) Remove fuel control drain plug and drain fuel from the fuel control and hoses.

(5) Remove overspeed governor and drain fuel.

(6) Connect fuel hoses and replace drain plug.

(7) Safety throttle to CLOSED position.

(8) Pour oil (C192) into openings made accessible by removal of overspeed governor until the fuel regulator is filled.

(9) Pour oil (C192) into overspeed governor while rotating driveshaft by hand.

(10) Pour excess lubricating oil from overspeed governor and install.

(11) Install engine inlet and exhaust covers, or if not available, seal openings with greaseproof barrier material (C115) and secure with tape (C279).

(12) Seal the gap between the bleed band and compressor housing by encircling the engine with a narrow strip of barrier material (C115) and secure with tape (C279).

(13) Visually check entire engine to ensure:

(a) All holes are plugged.

(b) All ports are capped.

(c) All external parts are complete and secure.

(d) All bare metal including internal and external threads is covered with corrosion preventive compound (C86).

(14) Attach a tag to controls stating, FUEL CONTROL HAS BEEN PRESERVED WITH MIL-L-6081 OIL. FLUSH WITH STANDARD FUEL BEFORE PLACING IN SERVICE.

(15) Record date and extent of engine preservation in helicopter records.

d. **Rotors and Controls.**

(1) Lubricate rotor system in accordance with lubrication order, Chapter 1.

**WARNING**

**Cleaning materials are flammable and toxic. Avoid skin contact and breathing of solvent vapors.**

(2) Apply fingerprint remover (C88) to all unpainted metal surfaces. Remove residue with solvent (C261) and a clean cloth.

**WARNING**

Cleaning materials are flammable and toxic. Avoid skin contact and breathing of solvent vapors.

(3) Wipe all parts dry with a clean lint-free cloth and apply corrosion preventive compound (C86) on all unpainted surfaces not in contact with bearings.

(4) Clean surface of rotor blades with cleaning compound (C67). Wipe blades completely dry with clean lint free cloth.

(5) Delete

**WARNING**

Cleaning materials are flammable and toxic. Avoid skin contact and breathing of solvent vapors.

(6) Apply a light coat of corrosion-preventive compound (C88) to tail rotor cables, sprocket and chain. Cycle controls through full range for complete coverage.

**e. Landing Gear.**

(1) Place blocks or shoring under skid tubes to provide free air passage.

(2) Clean skid/crosstubes and treat for corrosion in accordance with TM 55-1500-204-25/1 .

**WARNING**

Cleaning materials are flammable and toxic. Avoid skin contact and breathing of solvent vapors.

(3) Repaint any exposed metal surfaces. If paint cannot be touched up, coat bare metal surfaces with corrosion preventive compound (C88).

**f. Hydraulic System.**

(1) Fill hydraulic reservoir with fluid (C131).

(2) Wipe exposed portions of hydraulic boost cylinder actuator pistons with lint-free cloth moistened with hydraulic preservative fluid (C 132).

**g. Avionics.**

(1) Remove, attach condition tags, and turn-in all headsets and microphones to Supply.

(2) Leave all unclassified installed avionic equipment in helicopter.

**h. Fuel System.** Maintain fuel tanks FULL for the duration of the storage period to preclude condensation. Drain water from tanks before adding fuel. If a requirement exists to drain tanks, refer to Intermediate Storage.

**i. Battery**

(1) Remove battery and turn in to the battery shop.

(2) Clean battery compartment, quick disconnect plug, cables, battery shelf, and vent hoses with a solution of five ounces boric acid crystals dissolved in one gallon of water. Rinse with clean water and allow to dry.

(3) Seal the battery vent tubes and cover the quick-disconnect plug with barrier material (C115) secured with tape (C279).

**j. Airframe.**

(1) Park and moor helicopter with main and tail rotor tiedowns installed in accordance with Chapter 1.

(2) Remove clock, fire extinguishers, and first aid kits. Tag for condition and transfer to Supply to prevent possible pilferage.

(3) Apply pitot cover or cover pitot head and static ports with barrier material (C115) secured with tape (C279).

(4) Remove windshield wipers and blades. Wrap, tag, and store in the cockpit.

(5) Close all doors, windows, inspection panels, and cowling.

(6) Clean all exposed antennas and connections.

(7) Close all openings or voids not already covered with barrier material (C98) secured with tape (C221).

(8) Cover windshield with cover.

(9) Install static ground wire.

(10) Install storage covers, if available, in accordance with instructions accompanying covers.

(11) Annotate helicopter records to reflect short term storage.

#### **E - 1 0 .   M A I N T E N A N C E            O F P R E S E R V A T I O N   D U R I N G   S H O R T T E R M S T O R A G E .**

a. Inspect helicopters in accordance with local directives and those requirements outlined in paragraph E-3.

b. Should conditions change so that the helicopter is to remain in storage for a longer period of time than 45 days, represerve it in accordance with Section IV.

#### **NOTE**

**Do not renew Short Term Storage.**

#### **E-11.    D E P R E S E R V A T I O N   A F T E R S H O R T   T E R M   S T O R A G E .**

##### **a. Airframe.**

(1) Remove storage covers, clean, and return to supply.

(2) Remove static ground wire.

**WARNING**

**Cleaning materials are flammable and toxic. Avoid skin contact and breathing of solvent vapors.**

(3) Remove, clean, and store windshield cover and barrier material/tape covering openings of voids. Remove tape residue with solvent (C261).

(4) Open all doors and windows to ventilate helicopter.

(5) Install windshield wipers and blades.

(6) Remove pitot cover and ensure static ports are open and free of tape residue.

(7) Replace clock, fire extinguisher, and first aid kit.

(8) Remove main/tail rotor tiedown and any mooring devices.

##### **b. Battery.**

(1) Remove barrier material/tape from vent tubes and quick-disconnect plug in battery compartment,

(2) Install battery, and after ensuring that all switches are off, attach quick-disconnect plug.

##### **c. Fuel System (tanks and lines).**

(1) Drain water from tanks.

(2) Inspect fittings and clamps.

(3) Sample fuel and test for contamination.

##### **d. Avionics.**

(1) Replace headsets and microphones.

(2) Ensure that all components including antennae are in place.

##### **e. Hydraulic System.**

(1) Check reservoir level and inspect system for leaks.

**WARNING**

**Cleaning materials are flammable and toxic. Avoid skin contact and breathing of solvent vapors.**

(2) Clean exposed portion of hydraulic boost cylinder actuator pistons with a clean cloth dampened with solvent (C261).

f. Landing Gear. Remove blocks or shoring under skid tubes.

g. Rotors and Controls

**WARNING**

Cleaning materials are flammable and toxic. Avoid skin contact and breathing of solvent vapors.

(1) Clean main and tail rotor assemblies with solvent (C261). Wipe dry with lint-free cloth.

(2) Ensure that corrosion preventive compound is removed from tail rotor control chain and sprocket.

(3) Lubricate in accordance with Chapter 1.

(4) Ensure stabilizer bar dampers have fluid (C129) to the proper level. Check timing after refilling and replace damper if unsatisfactory. (See Chapter 5).

h. Power-train.

**WARNING**

Cleaning materials are flammable and toxic. Avoid skin contact and breathing of solvent vapors.

(1) Using solvent (C261), clean all surfaces coated with corrosion preventive compound. Wipe dry with a clean cloth.

(2) Check sight gages for proper lubricant levels. Service as necessary in accordance with Chapter 1.

(3) Check and clean transmission oil filters.

i. Engine

(1) Remove covers of inlet, exhaust, and bleed band if applicable. Perform engine wash, paragraph 4-4b.

**WARNING**

Cleaning materials are flammable and toxic. Avoid skin contact and breathing of solvent vapors.

(2) Inspect opening for foreign material and corrosion. Wipe clean with solvent (C261).

(3) Remove chip detector from accessory drive gearbox and drain plugs from fuel control. After oil has drained, clean and replace chip detector (if serviceable) and plugs.

(4) Ensure ignition system igniter solenoid circuit breaker is not engaged.

(5) Disconnect main fuel hose from main fuel manifold or flow divider, as applicable, and drain into a container of at least two gallons capacity.

(6) Check oil level; service if necessary.

**CAUTION**

Do not exceed starter limitations.

(7) Operate helicopter boost pump to prime fuel system, then motor engine with starter.

(8) Move throttle to maximum open until a solid stream of fuel with no air bubbles is observed flowing into the container. At least one gallon of fuel must flow into the container.



NOTE

**Engine lubrication system is fully primed when oil pressure gage shows a steady positive indication.**

(9) Connect main fuel hose to main fuel manifold or flow divider, as

applicable, and inspect engine for leakage.

(10) Engage ignition system igniter solenoid circuit breaker.

(11) Operate the engine for approximately ten minutes at a minimum N2 rpm of 5500. Restrict the engine operation at IDLE position to a

maximum of two minutes in each period. Check all instruments for normal operation and ensure that the engine temperature has stabilized. (Refer to Operator's Manual.)

(12) Shut down engine,

(13) Remove oil filter, check for excessive condensation, clean and install.

(14) Remove chip detector, check for excessive contamination, clean and install.



Cleaning materials are flammable and toxic. Avoid skin contact and breathing of solvent vapors,

(15) Remove fuel inlet strainer and pump discharge strainer from fuel control. Check for contamination, clean with solvent(C261) and install. Replace servo supply filter.

(16) If no contamination is evident, engine is ready for ground test. If there is slight contamination, drain the oil, and refill the system with new oil.

(17) Repeat steps (11) through (15). Evidence of continued oil contamination requires a thorough investigation.

**NOTE**

**If there are fewer than ten hours operating time on engine since new or last overhaul, repeat steps (11 ) through (15) until no contamination is evident or analysis of the contamination determines that the engine must be replaced.**

**j. Miscellaneous.**

(1) Clean helicopter as necessary in accordance with Chapter 1

(2) Check helicopter records for components which had been removed or disconnected. Ensure that all have been replaced and connected.

(3) Ensure that all related systems have been properly depreserved and serviced before any system or component operational check is performed.

(4) Check that all procedures required to activate the helicopter from storage have been accomplished. Clear form entries.

(5) Perform daily inspection in accordance with PMD cards.

**SECTION IV – INTERMEDIATE STORAGE**

**E - 12. INSPECTION PRIOR TO STORAGE.**

**NOTE**

**The general requirements of Section I are a part of these procedures.**

a. Ensure that all removed components are preserved and either stowed in the helicopter or at a designated location.

b. Ensure that all removed or disconnected components are entered in the helicopter records.

c. Check fuel, oil, and hydraulic lines/,loses for leakage.

d. Lubricate the helicopter for 50 and 100 hour intervals in accordance with Chapter 1.

e. Ensure that bolts, nuts, and washers removed during disassembly are coated with corrosion , preventive compound (C86) and reinstalled in quantities and location exactly as removed from the major component unless otherwise specified.

f. Record the date and type of storage in the helicopter records.



**E-13. PRESERVATION.**

**a. Power-train.** Preserve the power-train in accordance with paragraph E-9a.

**b. Engine.** Preserve operable and inoperable engines in accordance with paragraphs E-9b and E-9c.

**c. Rotors and Controls.**

(1) Preserve in accordance with paragraph E-9d.

(2) Color code and remove rotor blades, clean with mild soap and water, place in blade containers, and store under cover.

**d. Landing Gear.** Process landing gear in accordance with paragraph E-9e.

**e. Hydraulic System.** Preserve in accordance with paragraph E-9f.

**f. Avionics.** Process in accordance with paragraph E-9g.

**g. Fuel System.**



**Observe all safety precautions when purging fuel cells. Use only approved equipment and methods. Refer to TM 55-1500-204-25/1.**

(1) Drain the fuel tanks in accordance with Chapter 1.

(2) Add five gallons diesel fuel and drain. This should remove any residual fuel which puddled at the bottom of the tank.

(3) Open fuel line and activate boost pump to remove fuel at pump sump.

(4) Repeat steps (2) and (3) using lubricating oil (C192).

(5) Spray the inside of the accessible tank with oil (C192).

(6) Drain the oil and test tanks with a Combustible Gas Indicator. If a dangerous level of fuel fumes exists, flush tanks with fresh lubricating oil until a safe reading is obtained.

(7) Tag fuel cap to read THIS FUEL SYSTEM HAS BEEN PRESERVED WITH MIL-L-6081OIL. Flush with standard fuel before placing in service.

**h. Damaged Fuel Systems.**

(1) Open fuel cells in accordance with Chapter 1, and ventilate tanks with rapidly moving dry air until fumes are below the danger level as indicated by testing with a Combustible Gas Indicator.

(2) Preserve the tanks by spraying with oil (C192) through access openings. Coat the entire interior surface.

(3) Tag the fuel system to read TANKS PRESERVED WITH MIL-L-6081 oil

**i. Battery.** Preserve battery in accordance with paragraph E-9i.

**j. Airframe.** Except for rotor blade securement, prepare in accordance with paragraph E-9

**E - 14. MAINTENANCE OF PRESERVATION DURING INTERMEDIATE STORAGE.**

**a.** Inspect helicopter in accordance with local directives and those requirements outlined in paragraph E-3.

**b.** Applicable portions of preventive maintenance daily inspection shall be performed at least once every 30 days in accordance with PMD cards.

**c.** If conditions change so that a helicopter prepared for Intermediate Storage is to remain in storage for a longer period of time, represerve the helicopter at the end of 180 days.

**E - 15. DE PRESERVATION AFTER INTERMEDIATE STORAGE.**

**a.** Airframe. Depreserve helicopters in accordance with paragraph E-11a(1)

**b.** Electrical System. Prepare for flight in accordance with paragraph E-11b.

**c.** Avionics. Prepare for flight in accordance with paragraph E-11d.

**d. Hydraulics.** Depreserve in accordance with E-11e.

**e. Landing Gear.** Remove blocks or shoring from under skid tubes

**f. Rotors and Controls.**

(1) Depreserve in accordance with paragraph E-11g.

(2) Replace main and tail blades on hubs in same position as before removal.

**g. Power-train.** Depreserve in accordance with paragraph E-11h

**h. Engine/Fuel System.**

(1) Drain fuel tanks of any accumulated oil.

(2) Add five gallons operating fuel (C 119) to flush tanks. Drain.

(3) Fill tanks with operating fuel. Check for leaks.

(4) Depreserve engine in accordance with paragraph E-1 li.

**i. Miscellaneous**

(1) Clean helicopter as necessary in accordance with Chapter 1.

(2) Ensure that all removed components have been installed on/in helicopter. Check the records for identification of components which have been removed or disconnected. Check for subsequent Installation or connection.

(3) Determine that all related systems have been properly depreserved and serviced before any system or component operational check is performed.

(4) Perform any necessary inspection required by helicopter records in accordance with Chapter 1

(5) Remove static ground wire.

(6) Ensure all necessary entries are made in helicopter records and indicate in logbook that helicopter has been depreserved and removed from storage.

SECTION V .

STORAGE OF AIRCRAFT  
UNDERGOING MAINTENANCE .

E-16 Helicopters in this category require individual determination as to the degree of protection and inspection necessary while undergoing maintenance. Varying environmental conditions may justify an increase or decrease in the degree of protection needed. Some factors which should be considered are: humidity, temperature, actual location of aircraft (hangered or outside). Depending on the nature of the maintenance being performed certain inspections may not be necessary.

E-17. PRESERVATION.

In general, when appropriate, the preservation requirements of aircraft in flyable storage are applicable to this storage category. Aircraft that are hangered are relieved from the ground run-up> installation of protective covers, and the requirement for full fuel tanks. If deemed appropriate, additional preservation measures from sections III and IV may be taken.

E-18. MAINTENANCE OF PRESERVATION OF  
AIRCRAFT UNDERGOING MAINTENANCE.

a. Daily inspections shall be scheduled at the discretion of the maintenance officer.

b. Helicopter shall be inspected in accordance with local directives and requirements of preceding paragraph E-3 when applicable.

E-19. DEPRESERVATION AFTER STORAGE DURING  
MAINTENANCE.

General maintenance procedures shall be followed for release of aircraft after all maintenance action has been completed.

## APPENDIX F

## WIRING DIAGRAMS

## F-1. WIRING DIAGRAMS

**F-2. Description — Wiring Diagrams**

This appendix contains wiring diagrams, and essential wiring information for the electrical systems and circuits in the UH-1 D/H helicopter to assist maintenance personnel in understanding the circuits and components installed in the helicopter and in troubleshooting and tracing of inoperative and malfunctioning circuits.

## NOTE

**Master wiring diagrams are not furnished for helicopters S/N 65-9565 and subsequent. In lieu of master wiring diagrams, individual system wiring diagrams are furnished to provide easier circuit analysis, troubleshooting, and tracing of inoperative and/or malfunctioning circuits.**

## F-3. WIRING DATA.

**F-4. Wire Identification.** All wires on diagrams are identified by coded wire numbers exactly as they are marked in the helicopter. The coded wire numbers indicate circuit function, wire number, wire segment letter, and wire size (gage). (See figure F-1.)

**F-5, Abbreviations.** Abbreviations are in accordance with MIL-STD-12C and AR310-50, except when the abbreviation depicts a marking or decal contained in or on the helicopter.

**F-6. Symbols.** Wiring diagram component symbols are drawn in accordance with ANSI Y14. 15, Part 1. The symbols chart (figure F-2) illustrates electrical symbols used on the wiring diagrams.

## F-7. EQUIPMENT LISTS.

**F-8. Description — Equipment Lists.** Tables F-1 through F-4 list each item of equipment shown on the electrical system wiring diagrams. Each item of equipment is identified by the reference designator and nomenclature.

## F-9. CONNECTOR REPLACEMENT CHART.

**F-10. Description — Connector Replacement Chart.** The purpose of the connector replacement chart (table F-5) is to provide maintenance-personnel with necessary information to replace (resolder or crimp) a damaged electrical connector. The chart contains the connector code item numbers, the connector pin letters or numbers, and the wire number that installs in each respective pin. Only those connectors that are not shown in their entirety in one of the system diagrams are presented in table F-5.

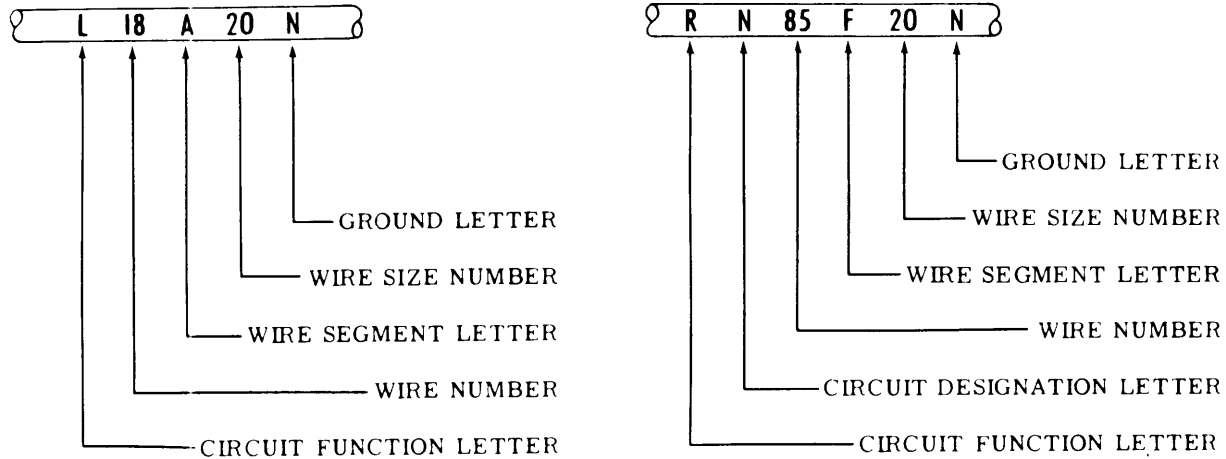
## F-11. WIRING DIAGRAM INDEX.

## NOTE

**System wiring diagrams with no effectivity listing cover helicopter blocks 65-9565 and subsequent.**

<b>Title</b>	<b>Figure</b>
Electrical Schematic (64-13492 thru 64-13901) .....	F-3
Electrical Wiring Diagram (64-13492 thru 64-13901) .....	F-4
RPM Limit Warning Test Set .....	F-5
RPM Limit Warning Test Set Schematic-BHT Model 205-074-033-103 .....	F-6
Mission Antennas OE-201/ARQ-33 and OE-202/ARQ-33 .....	F-7
High Performance Hoist System .....	F-8
Door Gunners Foot Mike Switch .....	F-9
Altimeter AAU-31/A and AAU-321A and Transponder .....	F-10
AN/APX-72 Interconnecting Wiring Diagram .....	F-11 1
Tachometer Generator System .....	F-12
AC Pressure Indicator System .....	F-13
Temperature Bulb, Turn and Slip Indicator .....	F-14
Exhaust Temperature Indicator System .....	F-15
Pilot Heater System.....	F-16
Attitude Indicator System.....	F-17
Fuel Quantity System .....	F-18
<b>HVE</b> Battery System.....	F-18.1
<b>EB:</b> Battery System .....	F-19
External Power System .....	F-19.1
<b>EB</b> External 3 Phase Power System.....	F-20
Generator and Bus System .....	F-20.1
<b>EB</b> Generator and Bus System .....	F-21
AC Power System .....	F-21.1
<b>EB</b> Alternator System.....	F-22
Starter System.....	F-22.1
External 3 Phase Power System .....	F-23
Ignition System.....	F-24
Cockpit, Dome and Crew Lights System.....	F-25
Instrument, Console, and Pedestal Lights System.....	F-25.1
ARC-201 Panel Lighting (MWO 55-1520-210-50-21) .....	F-25.2
Night Vision Goggles.....	F-26
Caution Lights System.....	F-26.1
5-Volt Instrument Lighting System .....	F-27
RPM Warning System .....	F-28
Landing and Searchlight System.....	F-29
Navigation, Fuselage, and Anticollision Lights System .....	F-30
De-ice and Ice Detector System.....	F-31
Fuel Boost and Fuel Valve System .....	F-32
Governor Control and Idle Stop Systems.....	F-33
Force Trim and Hydraulic Control System .....	F-34
Cabin Heating System.....	F-35
Heated Blanket Receptacle Wiring Diagram .....	F-36
Windshield Wiper System .....	F-37
Cargo Hook System .....	F-38
Rescue Hoist System .....	F-38.1
High Performance Utility Helicopter Hoist System .....	F-39
External Fuel System .....	F-40
Fire Detector System.....	F-41
Armament Wiring Diagram .....	F-42
Electrical Schematic (62-2106 thru 62-2113, 62-12351 thru 62-12372) .....	F-43
Electrical Wiring Diagram (62-2106 thru 62-2113, 62-12351 thru 62-12372) .....	F-44
Electrical Schematic (63-8739 thru 63-8859, 63-12956 thru 63-13002) .....	F-45
Electrical Wiring Diagram (63-8739 thru 63-8859, 63-12956 thru 63-13002) .....	F-45

**WIRING IDENTIFICATION CODE**



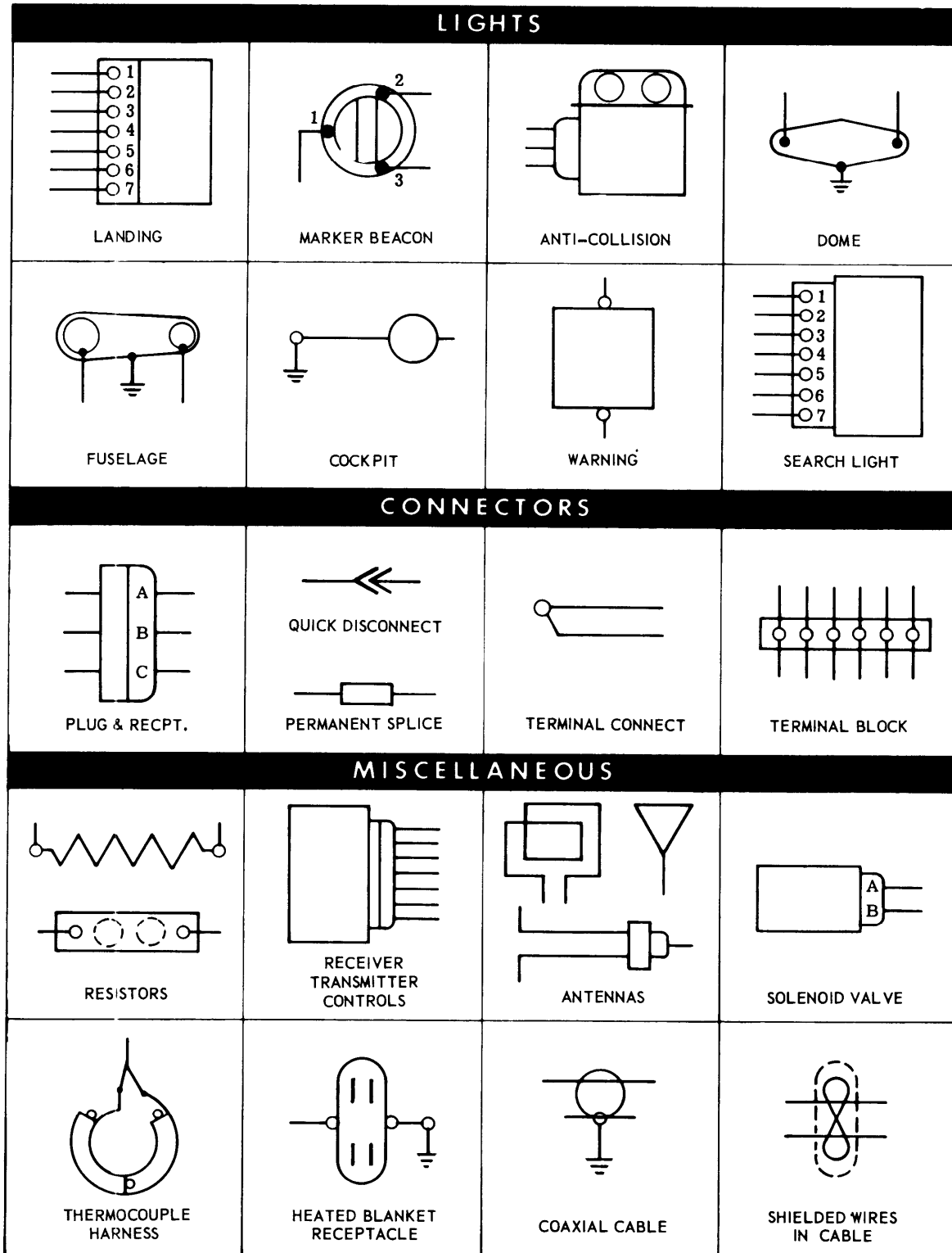
**CIRCUIT FUNCTIONS**

<u>CODE</u>	<u>NOMENCLATURE</u>	<u>CODE</u>	<u>NOMENCLATURE</u>
A	ARMAMENT	RC	COMMAND
C	CONTROL SURFACES	RF	VHF LIAISON
D	INSTRUMENTS (OTHER THAN FLIGHT OR ENGINE)	RL	LIAISON
E	ENGINE INSTRUMENTS	RM	MARKER BEACON
F	FLIGHT INSTRUMENTS	RN	NAVIGATION
H	HEATING, VENTILATING AND DE-ICING	RU	UHF COMMAND
J	IGNITION	RV	VHF COMMAND
K	ENGINE CONTROL	RZ	INTERPHONE AND HEADPHONE
L	LIGHTING	S	RADAR
M	MISCELLANEOUS ELECTRIC	SX	RECOGNITION (IFF)
N	GROUND	TN	TRACKING NAVIGATION
P	DC POWER	V	DC POWER AND DC CONTROL CABLES FOR AC SYSTEM
Q	FUEL AND OIL	W	WARNING AND EMERGENCY
R	RADIO (NAVIGATION AND COMMUNICATION)	X	AC POWER

204475-34C  
AV 054194

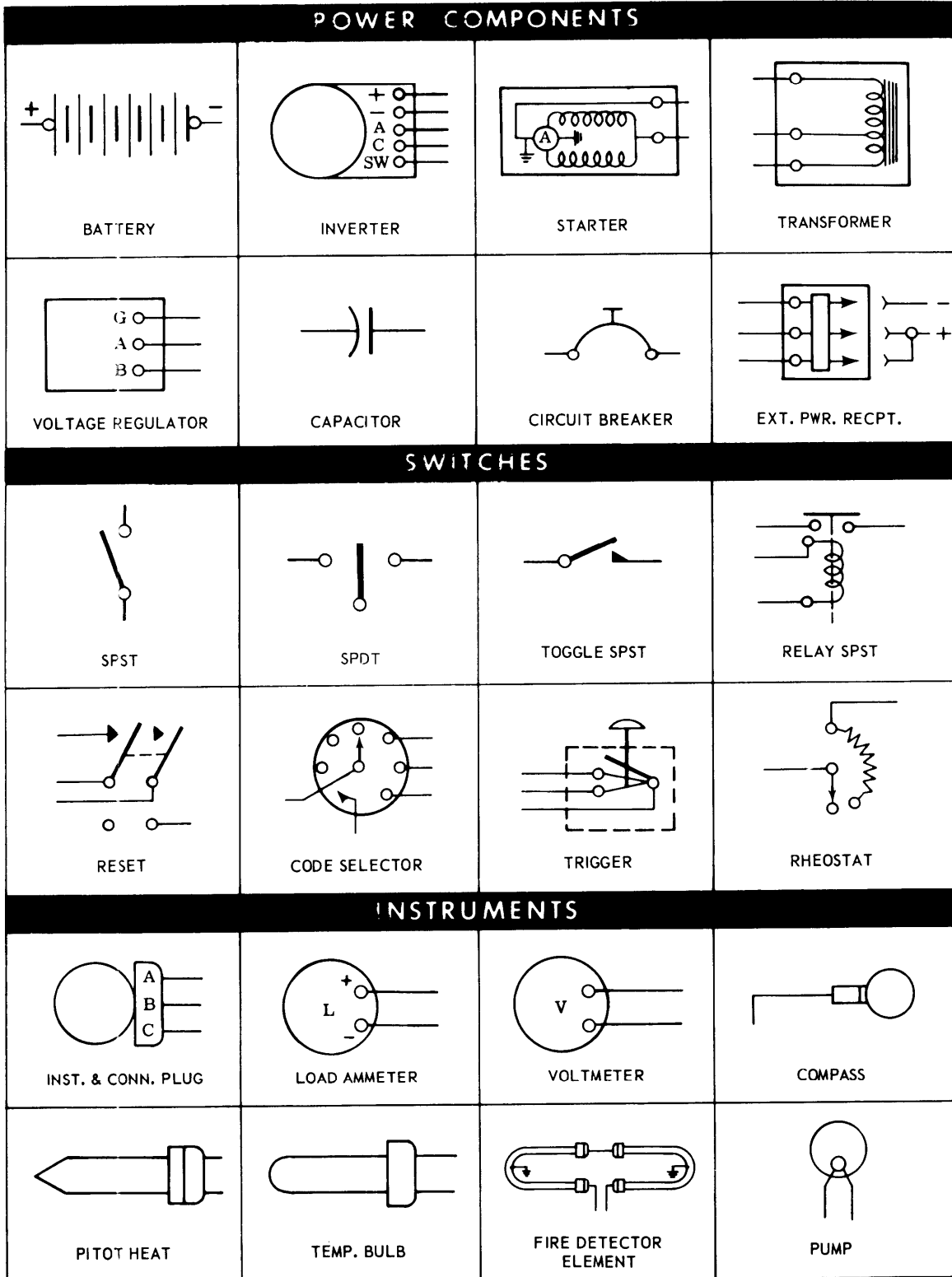
Figure F-1. Wiring identification code





204075-8-1  
AV 052206-1

Figure F-2. Electrical symbol chart (Sheet 1 of 2)



204075-8-2  
AV 052206-2

Figure F-2. Electrical symbol chart (Sheet 2 of 2)

Table F-1. Equipment List - Helicopters Serial No. 65-9565 Through 65-12895

ITEM NO.	DESCRIPTION	ITEM NO.	DESCRIPTION
A1	Panel, DC Power	E2	Detector, Magnetic Chip
A2	Panel, AC Power	E3	Detector, Magnetic Chip
A3	Panel, Engine	E4	Detector, Magnetic Chip
A4	Panel, Caution	G2	Generator, 30 VDC (300A)
A6	Panel, Instrument Lights	G3	Generator, Tach. (Gas Prod.)
A?	Panel, Exterior Lights	G4	Generator, Tach. (Pwr. Turb.)
A8	Panel, Hydraulic Control	G5	Generator, Tach. (Rotor)
A10	Panel, Miscellaneous	G6	Generator, Starter 28V (200A)
A11	Panel, Heating	HR1	Heater, Pitot Tube
A12	Cargo Hook Assembly	11	Indicator, Attitude (Copilot)
A13	Panel, Resistor	12	Indicator, Fuel Quantity
A14	Panel, AC Circuit Breaker	13	Indicator, Torque - Pilot
A15	Panel, Overhead Console	14	Indicator, Oil Pressure (Engine)
A20	Panel Assembly, Aft Dome Lights	15	Indicator, Oil Pressure (XMSN)
A21	Panel, Dome Lights & Pitot Heater	16	Indicator, Fuel Pressure
A26	Panel, Assembly, Ext. Fuel	17	Indicator, Tach. (Gas Prod.)
B1	Syncro XMTR Torque Pressure	18	Indicator, Tach- Dual (Pilot)
B3	Syncro XMTR, XMSN Oil Pressure	19	Light, Utility (Pilot)
B3	Syncro XMTR, Engine Oil Pressure	110	Light, Dome
B4	Syncro XMTR, Fuel Pressure	111	Light, Search
B5	Motor, Fuel Shutoff Valve	I12	Light, Fire Warning
B6	Motor, R/H Fuel Boost Pump	113	Light, Master Caution
B7	Motor, Windshield Wiper	114	Light, Instrument Secondary
B8	Motor, R/H Aux. Fuel Pump	I15	Lamp, Instrument & Edge Lights
B12	Motor, Gov. RPM Actuator	116	Light, Landing
B13	Motor, L/H Aux. Fuel Pump	I17	Light, Left Navigation
B19	Motor, Bleed Air Valve	118	Light, Right Navigation
B31	Motor, Copilot Windshield Wiper	I19	Light, Tail
BT2	Battery	I20	Light, Top Fuselage
C1	Capacitor, PF Corr. (MIL-C-25)	121	Indicator, XMSN Oil Temp.
C 7	Capacitor, Filter, JN14	122	Indicator, Engine Oil Temp.
CB1	Circuit Breaker (5A)	123	Indicator, Turn & Slip (Pilot)
CB2	Circuit Breaker (10A)	125	Light, XMSN Sump Inspect
CB3	Circuit Breaker (15A)	126	Light, Bottom Fuselage
CB4	Circuit Breaker (20A)	I28	Light, Utility (Copilot)
CB5	Circuit Breaker (25A)	131	Indicator, Exh. Temp. (Pilot)
CB6	Circuit Breaker (1A)	I34	Standby Compass (Pilot)
CB7	Circuit Breaker (35A)	I40	Light, Anti-Collision
CB8	Circuit Breaker (2A)	142	Indicator, Attitude (Pilot)
CB11	Circuit Breaker (7.5A)	I44	Light, Cargo Release Armed
CB12	Circuit Breaker (50A)	145	Light, Hi-Lo RPM Warn.
CP1	Coupler, Fuel Qty. Sys. "J" Box, Unshielded	172	Light, Air Filter, Warning
CP2	Coupler, Fuel Qty. Sys. "J" Box, Shielded	J2	Recept. Pitot Tube Heater
CR2	Diode, Ext. Power Relay	J3	Recept. Instrument Panel Disc.
CR30	Diode, Batt. Voltage Fwd. Loc	J4	Recept. Fuel Quantity Ind.
CR31	Diode, Batt. Voltage Aft Loc	J5	Recept. Fuel Pressure Ind.
D1	Inverter, 250 V.A. 3 Ph (Main)	J6	Recept. Copilot Att. Ind.
D2	Inverter, 250 V.A. 3 Ph (Spare)	J?	Recept. Engine Oil Temperature Ind.
DS1	Control Assembly, RPM Warn.	J8	Recept. Engine Oil Pressure Ind.
E1	Detector, Magnetic Chip	J9	Recept. Pilot Dual Tach. (Rotor)
		J10	Recept. Pilot Dual Tach. (Pwr. Turb.)
		J11	Recept. XMSN Oil Temperature Ind.
		J12	Recept. XMSN Oil Pressure Ind.
		J13	Recept. Pilot 5V Power Supply
		J14	Recept. Copilot 5V Power Supply

Table F-1. Equipment List - Helicopters Serial No. 65-9565 Through 66-12895 (Cont)

ITEM NO.	DESCRIPTION	ITEM NO.	DESCRIPTION
J15	Recept. Pilot Torque Meter	J106	Recept. Heated Blanket R/H
J16	Recept. Pilot Turn & Slip Indicator	J107	Recept. Copilot Collective Stick
J17	Recept. Gas Prod. Tach.	J108	Recept. Fuel Diff. Pressure Sw.
J20	Recept. Pilot Cyclic Stick	J109	Recept. Ext. Power
J21	Recept. Hydraulic Control Panel	J110	Recept. Anti-Collision Lt. Disc.
J22	Recept. Copilot Cyclic Stick	J111	Recept. Anti-Collision Lt.
J23	Recept. Engine Panel	J112	Recept. Msg. Brake, Anti-Torque
J24	Recept. Caution Panel	J113	Recept. Msg. Brake, Fore & Aft
J25	Recept. Pilot Collective Stick	J114	Recept. Msg. Brake Lat.
J26	Recept. Windshield Wiper	J115	Recept. Test-Eng. Vibration Meter
J28	Recept. Hydraulic Bypass Solenoid	J127	Recept. Var. Mix Valve Disc.
J29	Recept. Hydraulic Press. Warning Sw.	J129	Recept. Displacement-Roll & Pitch Gyro
J31	Recept. Cargo Hook	J130	Recept. Rate Switching Gyro
J32	Recept. Cargo Sling Disc.	J131	Recept. Attitude Ind.
J35	Recept. Rotor, Tach. Gen.	J135	Recept. Ice Interpreter
J36	Recept. XMSN Oil Pressure Sw.	J136	Recept. Ice Interpreter
J37	Recept. XMSN Oil Temperature Bulb	J138	Recept. Door Post Outlet Valve Act.
J38	Recept. Copilot Windshield Wiper	J146	Recept. Bleed Air Valve
J39	Recept. XMSN Oil Pressure XMTR	J147	Recept. Internal Aux. Fuel Disc. L/H
J41	Recept. XMSN Disc.	J148	Recept. Internal Aux. Fuel Disc. R/H
J42	Recept. Fuel Tank Disc. L/H	J155	Recept. Hi-Lo RPM Warn.
J43	Recept. Compensator Fuel Tank Disc L/H	J156	Recept. Eng. Fuel Filter Bypass Sw.
J44	Recept. Fuel Tank Disc L/H	J166	Recept. Aft, Outlet Valve
J53	Recept. Bulkhead Feed-thru-Aft Fuel Cell	J191	Recept. Main Inverter Power
J54	Recept. Bulkhead Feed-thru-Aft Fuel Cell	J192	Recept. Spare Inverter Power
J57	Recept. Ext. Fuel Cont. Panel	J194	Recept. Engine Chip Detector
J60	Recept. Socket, Relay-Gen Field	J1017	Recept. Ext. Fuel Disc. L/H
J64	Recept. Torque Press. XMTR	J1024	Recept. Ext. Fuel Disc. R/H
J65	Recept. Engine Oil Press. XMTR		
J66	Recept. Fuel Pressure XMTR	K1	Relay, External Power
J68	Recept. Disc. Muff Heater	K2	Relay, Non- Essential Bus
J71	Recept. Engine Fuel Valve	K3	Relay, Starter
J72	Recept. Engine Oil Pressure Sw.	K4	Relay, Bus Cont. (Gen. Fail)
J74	Recept. Batt. Disc.	K5	Relay, Reverse Curr (Main)
J75	Recept. Navigation Lts. Flasher	K6	Relay, Over Voltage
J77	Recept. Ice-Detector	K7	Relay, Generator Field
J80	Recept. Engine Air Pressure Sw.	K8	Relay, AC Failure
J81	Recept. Starter Deck	K9	Relay, Battery
J84	Recept. De-Icing, Hot Air Valve	K10	Relay, Fuel Transfer
J85	Recept. Engine Oil Temp. Bulb	K23	Relay, Standby Gen. Rev. Curr
J86	Recept. Power Turb. Tach.	K24	Relay, Cargo, Hook Release
J87	Recept. Gas Turb. Tach.	K27	Relay, Inverter
J88	Recept. Ignition Unit, Engine	K35	Relay, Main Invtr. Power
J89	Recept. Primer Valve (Fuel Ign. Sol.)	K36	Relay, Spare Invtr. Power
J90	Recept. Fuel Cont. Sol. Valve	K37	Relay, Lo- Fuel Caution Light
J91	Recept. Engine Disc.	K38	Relay, Lo- Fuel Caution Light
J92	Recept. Engine Fwd. Disc.	K46	Relay, Overheat
J93	Recept. Fire Det. Fwd. Disc.	K65	Relay, Battery, Aft Loc
J94	Recept. Fire Det. Element R/H	K66	Relay, Battery Feeder
J95	Recept. Fire Det. Element L/H		
J96	Recept. Fire Det. Element R/H	L1	Solenoid, Primer (Ignition)
J97	Recept. Fire Det. Element L/H	L2	Solenoid, Fuel Cont. Valve
J98	Recept. Tail Light Disc.	L4	Solenoid, Hydraulic Bypass
J99	Recept. Thermocouple Disc.	L6	Solenoid, Hot Air De-icer
J102	Recept. Standby Compass (Pilot)	L?	Solenoid, Idle Stop Rel.
J105	Recept. Heated Blanket L/H	L8	Msg. Brake Anti-Torque Force Trim

Table F-1. Equipment List - Helicopters Serial No. 65-9665 Through 65-12895 (Cont)

ITEM NO.	DESCRIPTION	ITEM NO.	DESCRIPTION
L9	Msg. Brake Fore & Aft Force Trim	P66	Plug, Fuel Press. XMTR
L10	Msg. Brake Lat. Force Trim	P68	Plug, Muff Heater Disc.
L14	Solenoid, Door Post Htr. Outlet Valve	P71	Plug, Fuel Valve Shut-off
L15	Solenoid, Aft Outlet Valve Act.	P72	Plug, Engine Oil Press. Sw.
M1	Meter, DC Load (Stand-By-Gen.)	P74	Plug, Battery Disc. Fwd.
M2	Meter, DC Volts	P75	Plug, Navigation Lights Flasher
M3	Meter, AC Volts	P77	Plug, Ice Detector
M4	Meter, DC Load (Main Gen)	P80	Plug, Eng. Air Pressure SW.
02	Guard - Generator SW-DC Pwr. Panel	P81	Plug, Starter Deck
P2	Plug, Pitot Tube Heater	P84	Plug, De-Iceing Hot Air Valve
P3	Plug, Instrument Panel Corm.	P85	Plug, Oil Temp. Bulb
P4	Plug, Fuel Qty. Ind.	P86	Plug, Power Turb. Tach.
P5	Plug, Fuel Press. Ind.	P87	Plug, Gas Prod. Tach.
P6	Plug, Copilot Att. Ind.	P88	Plug, Ignition Unit- Eng.
P?	Plug, Engine Oil Temp. Ind.	P89	Plug, Ignition Sol. Valve
P8	Plug, Engine Oil Press. Ind.	P90	Plug, Fuel Cont. Sol. Valve
P9	Plug, Pilot Dual Tach. (Rotor)	P91	Plug, Engine Disc.
P10	Plug, Pilot Dual Tach. (Pwr. Turb.)	P92	Plug, Engine Forward Disc.
P11	Plug, XMSN Oil Temp. Ind.	P93	Plug, Fire Det. Forward Disc.
P12	Plug, XMSN Oil Press. Ind.	P94	Plug, Fire Det. Element R/H
P13	Plug, Pilot 5V Power Supply	P95	Plug, Fire Det. Element L/H
P14	Plug, Copilot 5V Power Supply	P96	Plug, Fire Det. Element R/H
P15	Plug, Pilot, Torque Meter	P97	Plug, Fire Det. Element L/H
P16	Plug, Pilot, Turn & Slip Ind.	P98	Plug, Tail Light Disc.
P17	Plug, Gas Prod. Turb. Tach	P99	Plug, Thermocouple Disc. - Engine
P20	Plug, Pilot's Cyclic Stick	P99A	Plug, Thermocouple Disc. - Engine
P21	Plug, Hydraulic Cont. Panel	P99B	Plug, Thermocouple Disc. - Engine
P22	Plug, Copilot Cyclic Stick	P102	Plug, Standby Compass (Pilot)
P23	Plug, Engine Panel	P107	Plug, Copilot Coil. Stick
P24	Plug, Caution Panel	P108	Plug, Fuel Diff. Press. Sw.
P25	Plug, Pilot Collective Stick	P110	Plug, Anti-Collision Light Disc.
P26	Plug, Windshield Wiper	P111	Plug, Anti-Collision Light
P28	Plug, Hyd. Bypass Sol. Valve	P112	Plug, Msg. Brake Anti-Torque
P29	Plug, Cargo Hook	P113	Plug, Msg. Brake Fore and Aft
P32	Plug, Cargo Hook Disc.	P114	Plug, Displacement, Roll & Pitch Gyro
P35	Plug, Rotor Tach. Gen.	P130	Plug, Rate Switching Gyro
P36	Plug, XMSN Oil Pressure Sw.	P131	Plug, Attitude Ind.
P37	Plug, XMSN Oil Temp. Bulb	P135	Plug, Ice-Interpreter
P38	Plug, Copilot Windshield Wiper	P136	Plug, Ice-Interpreter
P39	Plug, XMSN Oil Press. XMTR	P138	Plug, Door Post - Aft Outlet Valve Act.
P41	Plug, XMSN Disc.	P146	Plug, Bleed Air Valve
P42	Plug, Shielded Tank Unit Disc L/H Tank	P147	Plug, Unshielded Tank Coupler Disc.
P43	Plug, Monitor Tank Unit DISC L/H Tank	P148	Plug, Unshielded Tank Coupler Disc.
P44	Plug, Unshielded Tank Unit Disc. L/H Tank	P149	Plug, Unshielded Tank Coupler Disc.
P46	Plug, Fuel Tank Disc. L/H Cell	P151	Plug, Shielded Tank Coupler Disc.
P47	Plug, Fuel Tank Disc. L/H Cell	P152	Plug, Shielded Tank Coupler Disc.
P48	Plug, Fuel Tank Disc. L/H Cell	P153	Plug, Shielded Tank Coupler Disc.
P53	Plug, Unshielded Tank Unit Aft Cell	P155	Plug, Hi-Lo RPM Warning
P54	Plug, Shielded Tank Unit Aft Cell	P156	Plug, Engine Fuel Filter Bypass
P55	Plug, Fuel Tank Disc. - Aft Cell	P166	Plug, Aft Outlet Valve
P56	Plug, Fuel Tank Disc. - Aft Cell	P191	Plug, Inverter Disc. - Main
P57	Plug, Ext. Fuel Cont. Panel	P192	Plug, Inverter Disc. - Spare
P60	Plug, Field Relay Gen.	P194	Plug, Engine Chip Detector
P64	Plug, Torque Press. XMTR	P1017	Plug, Ext. Fuel Disc. L/H
P65	Plug, Eng. Oil Press. XMTR	P1024	Plug, Ext. Fuel Disc. R/H
		PS 1	Pilot, 5V Power Supply (PS-274B)
		PS 2	Copilot, 5V Power Supply (PS-274B)

Table F-1. Equipment List - Helicopters Serial No. 65-9565 Through 65-12895 (Cont)

ITEM NO.	DESCRIPTION	ITEM NO.	DESCRIPTION
R1	Shunt, Ammeter (Stby-Gen.)	S63	Switch, Ext. Fuel Jett.
R2	Shunt, Ammeter (Main Gen.)	S68	Switch, Force Trim
R3	Resistor, Windshield Wiper	S70	Switch, Starter-Generator
R4	Rheostat, Pilot Inst. Light Dim.	S73	Switch, Overheat Bleed Air
R5	Rheostat, Sec. Instrument Light Dim	S75	Switch, Search (ON STOW)
R6	Rheostat, Overhead Console	S76	Switch, Landing Light (ON-OFF)
R7	Resistor, Navigation Lights Dim	S77	Switch, Starter (Co pilot Coil.)
R8	Rheostat, Peal. Lights Dim	S78	Switch, Cargo Rel. (Copilot)
R9	Rheostat, Eng. Inst. Light Dim	S79	Switch, Fuel Ejector FLOW Sw. L/H
R10	Rheostat, Copilot Inst. Lights Dim	S80	Switch, Fuel Ejector Flow Sw. R/H
R11	Resistor, Fire Det. Cont.	S81	Switch, De-Ice (ON-OFF)
R12	Resistor, Spool Thermocouple	S83	Switch, Bleed Air (ON-OFF)
R21	Rheostat, Aft Dome Lights	S84	Switch, Bleed Air (HT-DEF)
R26	Rheostat, Course Ind. Light Dim	S85	Switch, Aft Outlet (Htr)
R27	Resistor, AC Load Balancing	S87	Switch, Aft- Outlet Limit
		S88	Switch, Start Fuel
S1	Switch, Aft Dome Light	S93	Switch, Hi-Low RPM
S2	Switch, Rotary (AC VM Sel.)	S94	Switch, Fuel Filter Bypass
S4	Switch, XMSN Sump Insp. Light	S111	Switch, Fuel Trans. Pump
S5	Switch, Fuel Quantity Test	S112	Switch, Pilot Hoist Cont.
S6	Switch, Starter (Pilot Coil.)	S114	Switch, Fire Control
S7	Switch, Hydraulic Boost Cont.	S115	Switch, Fire Control
S8	Switch, Gen. (ON-OFF Reset)	S124	Switch, Sel-Windshield Wiper
S9	Switch, Pitot Heater	S134	Switch, Chip Det. Sel.
S10	Switch, Force Trim (Copilot Cyc.)	S195	Switch, Diff. Pressure
S11	Switch, Rotary (AC VM Sel.)		
S12	Switch, Searchlight Cont.	T1	Transformer 115/28V
S13	Switch, Navigation Lights (Flash Steady)	TB1	Term. Blk, Forward Inst. Panel.
S14	Switch, Nav. Lights (Bright- Dim)	TB2	Term. Blk. Overhead Console R/H
S18	Switch, Force Trim (Pilot Cyc.)	TE3	Term. Blk. Overhead Console L/H
S20	Switch, Test (Fire Det.)	TB4	Term. Blk. Aft Fuel Cell
S23	Switch, Windshield Wiper	TB9	Term. Blk. Top Ext. & Dome Lights
S25	Switch, Landing Lt. (Ext. -Retr)	TB12	Term. Blk. Peal. Panel Edge Lights
S26	Switch, XMSN Oil Temp.	TB13	Term. Blk. Inst. Panel Lights
S27	Switch, Hydraulic Pressure	TB14	Term. Blk. Inst. Panel Sec. Ligh
S28	Switch, XMSN Oil Pressure Warn.	TB15	Term. Blk. Cockpit Lights L/H
S29	Switch, Engine Oil Pressure Warn.	TB16	Term. Blk. Cockpit Lights R/H
S31	Switch, Limit (Ext. Power Door)	TB25	Term. Blk. Thermocouple Ind.
S32	Switch, Cargo Release (Pilot)	TB26	Term. Blk. DC Grid. & Audio
S33	Switch, Governor (Auto-Emer.)	TB27	Term. Blk. Aft Thermo Lead
S35	Switch, Forward Dome Light	TB29	Term. Blk. Instrument Grid.
S36	Switch, Cargo Release	TB34	Term. Blk. Aft Dome Lt. Panel.
S37	Switch, RPM Gov. (Pilot)	TB35	Term. Blk. R/H Fuel Cell
S38	Switch, Fuel (ON-OFF)	TB36	Term. Blk. Ext. Power Diode
S39	Switch, Inverter (Main-Spare)	TB38	Term. Blk. L/H Fuel Cell
S40	Switch, Battery (ON-OFF)	TB39	Term. Blk. Electrical Compt. Aft
S41	Switch, Upper Float	TB60	Term. Blk. Batt. Voltage, Forward
S42	Switch, Lower Float	TB61	Term. Blk. Batt. Voltage, Aft
S44	Switch, Fuel- Low Level	TB100	Term, Blk. Pilot and Copilot 5V Power Supply
S45	Switch, Fuel- Transfer L/H	VR1	Regulator - Voltage (Main Gen.)
S46	Switch, Fuel-Transfer R/H	VR2	Regulator - Voltage (Stby Gen.)
S50	Switch, Idle Stop Rel (Pilot)		
S51	Switch, RPM Gov. (Copilot)	W1	Cable Assembly, Fire Det.
S58	Switch, Fuel Diff. Pressure		
S59	Switch, Anti- Coil. Light	Z2	Engine Ignition Unit
S62	Switch, Non-Ess Bus Cont.	Z3	Flasher Unit - Navigation Lights

Table F-1. Equipment List - Helicopters Serial No. 65-9565 Through 65-12895 (Cont)

ITEM NO.	DESCRIPTION	ITEM NO.	DESCRIPTION
Z5	XMSN Oil Temperature Bulb	Z16	Fuel Qty. Tank Unit - Aft
Z6	Engine Oil Temperature Bulb	Z17	Displacement - Roll and Pitch Gyro
Z8	Ice Interpreter	Z18	Rate Switching Gyro
Z9	Fire Det. Cont.	Z22	Fuel Qty. Tank Unit R/H Forward
Z13	Ice Detector		

**Table F-2. Equipment List- Helicopters Serial No. 66-746 Through 66-17144**



ITEM NO.	DESCRIPTION	ITEM NO.	DESCRIPTION
A1	Panel, DC Power	E1	Detector, Magnetic Chip
A2	Panel, AC Power	E2	Detector, Magnetic Chip
A3	Panel, Engine	E3	Detector, Magnetic Chip
A4	Panel, Caution	E4	Detector, Magnetic Chip
A6	Panel, Instrument Lights	G2	Generator, 30 VDC (300A)
A7	Panel, Exterior Lights	G3	Generator, Tach. (Gas Prod.)
	Panel, Hydraulic Cont.	G4	Generator, Tach. (Pwr. Turb.)
A10	Panel, Misc.	G5	Generator, Tach (Rotor)
A11	Panel, Heating	G6	Generator, Starter 28V (200A)
A12	Cargo, Hook Assembly	HR1	Heater, Pilot Tube
A13	Panel, Resistor	I1	Indicator, Attitude (Copilot)
A14	Panel, AC Circuit Breaker	I2	Indicator, Fuel Qty.
A15	Panel, Overhead Console	I3	Indicator, Torque - Pilot
A20	Panel, Assembly Aft Dome Lts.	I4	Indicator, Oil Press. (Eng.)
A21	Panel, Dome Light Pitot Heater	I5	Indicator, Oil Press. (XMSN)
A26	Panel, Assembly Ext. Fuel	I6	Indicator, Fuel Pressure
B1	Synchro XMTR, Torque Press.	I7	Indicator, Tach. (Gas Prod.)
B3	Synchro XMTR, XMSN Oil Press.	I8	Indicator, Tach. Dual (Pilot)
B3	Synchro XMTR, Eng. Oil Press.	I9	Light, Utility (Pilot)
B4	Synchro XMTR, Fuel Press.	I10	Light, Dome
B5	Motor, Fuel Shut-Off Valve	I11	Light Search
B6	Motor, R/H Fuel Boost Pump	I12	Light, Fire Warning
B7	Motor, Windshield Wiper	1 3	Light, Master Caution
B8	Motor, R/H Aux. Fuel Pump	I14	Light, Instrument Secondary
B12	Motor, Gov. RPM Actuator	I15	L amp, Instrument & Edge Lights
B13	Motor, L/H Aux. Fuel Pump	I16	Light, Landing
B19	Motor, Bleed Air Valve	I17	Light, Left Navigation
B22	Motor, Boom Actuator Hoist	I18	Light, Right Navigation
B31	Motor, Copilot Windshield Wiper	I19	Light, Tail
B33	Motor, Winch Assy. Hoist	I20	Light, Top Fuselage
B34 	Motor, Bleed Air Valve	I21	Indicator XMSN Oil Temp.
BT2	Battery	I22	Indicator, Engine Oil Temp.
C1	Capacitor, PF (Corr (MIL-C-25)	I23	Indicator, Turn & Slip (Pilot)
C7	Capacitor, Filter	I25	Light, XMSN Sump Inspect
CB1	Circuit Breaker (5A	I26	Light, Bottom Fuselage
CB2	Circuit Breaker (10A)	I28	Light, Utility (Copilot)
CB3	Circuit Breaker (15A)	I31	Indicator, Exhaust Temp. (Pilot)
CB4	Circuit Breaker (20A)	I34	Standby, Compass (Pilot)
CB5	Circuit Breaker (25A)	I40	Light, Anti-Collision
CB6	Circuit Breaker (1A)	I42	Indicator, Attitude (Pilot)
CB7	Circuit Breaker (35A)	I44	Light, Cargo Release Armed
CB8	Circuit Breaker (2A)	I45	Light, Hi- Lo RPM Warn.
CB11	Circuit Breaker (7.5A)	I72 	Light, Air Filter Warning
CB12	Circuit Breaker (50A)	J2	Recept. Pitot Tube Heater
CP1	Fuel Qty. Sys. "J" Box, Unshielded	J3	Recept. Instr, Panel Disc.
CP2	Fuel Qty. Sys. "J" BOX Shielded	J4	Recept, Fuel Qty. Ind.
CR2	Diode, External Power Relay	J5	Recept. Fuel Press. Ind.
CR30	Diode, Batt. Voltage Fwd. Loc	J6	Recept. Copilot Att. Ind.
CR31	Diode, Batt. Voltage Aft Loc	J7	Recept, Engine Oil Temp. Ind.
D1	Inverter (Main)	J8	Recept, Engine Oil Press. Ind.
D2	Inverter (Spare	J9	Recept. Pilot Dual Tach. Rotor
DS1	Control Assy, PM Warning	J10	Recept. Pilot Dual Tach. Pwr, Turb.



Table F-2. Equipment List - Helicopters Serial No. 66-746 Through 66-17144 (Cont)

ITEM NO.	DESCRIPTION	ITEM NO.	DESCRIPTION
J11	Recept. XMSN Oil Temp. Ind.	J102	Recept. Standby Compass (Pilot)
J12	Recept. XMSN Oil Press. Ind.	J105	Recept. Heated Blanket L/H
J13	Recept. Pilot 5V Power Supply	J106	Recept. Heated Blanket R/H
J14	Recept. Copilot 5V Power Supply	J107	Recept. Copilot Collective Stick
J15	Recept. Pilot Torque Meter	J108	Recept. Fuel Diff. Press. Sw.
J16	Recept. Pilot Turn & Slip Ind.	J109	Recept. External Power
J17	Recept. Gas Prod. Tach.	J110	Recept. Anti-Collision Light Disc.
J20	Recept. Pilot Cyclic Stick	J111	Recept. Anti-Collision Light
J21	Recept. Hydraulic Cont. Panel	J112	Recept. Msg. Brake Anti-Torque
J22	Recept. Copilot Cyclic Stick	J113	Recept. Msg. Brake Fore & Aft
J23	Recept. Engine Panel	J114	Recept. Msg. Brake - Lat.
J24	Recept. Caution Panel	J115	Recept. Test-Eng. Vibration Meter
J25	Recept. Pilot Collective Stick	J119	Recept. Cabin Roof Disc. Hoist
J26	Recept. Windshield Wiper (Pilot)	J127 <sup>△</sup>	Recept. Var. Mix. Valve Disc.
J28	Recept. Hydraulic Bypass Sol.	J129	Recept. Displacement Roll & Pitch Gyro
J29	Recept. Hydraulic Press. Warning Sw.	J130	Recept. Rate Switch Gyro
J31	Recept. Cargo Hook	J131	Recept. Attitude Ind.
J32	Recept. Cargo Sling Disc.	J135	Recept. Ice Interpreter
J35	Recept. Rotor, Tach. Gen.	J136	Recept. Ice Interpreter
J36	Recept. XMSN Oil Press. Sw.	J138	Recept. Door Post Outlet Valve Act.
J37	Recept. XMSN Oil Temp. Bulb	J146	Recept. Bleed Air Valve
J38	Recept. Copilot Windshield Wiper	J147	Recept. Internal Aux. Fuel Disc L/H
J39	Recept. XMSN Oil Press. XMTR	J148	Recept. Internal Aux. Fuel Disc. R/H
J41	Recept. XMSN Disc.	J155	Recept. Hi-Lo RPM Warning
J42	Recept. Fuel Tank Disc. L/H	J156	Recept. Engine Fuel Filter Bypass Sw.
J43	Recept. Compensator Fuel Tank Disc L/H	J166	Recept. Aft Outlet Valve
J44	Recept. Fuel Tank Disc. L/H	J191	Recept. Main Inverter Power
J53	Recept. Bulkhead Feed-thru-Aft Fuel Cell	J102	Recept. Spare Inverter Power
J54	Recept. Bulkhead Feed- thru-Aft Fuel Cell	J194	Recept. Engine Chip Detector
J57	Recept. Ext. Fuel Cont. Panel	J268	Recept. Hoist Cont. Box
J60	Recept. Socket, Relay-Gen-Field	J269	Recept. Hoist Cont. Box
J64	Recept. Torque Press. XMTR	J270	Recept. Hoist Cont. Box
J65	Recept. Engine Oil Press. XMTR	J271	Recept. Hoist Cont. Box
J66	Recept. Fuel Press. XMTR	J272	Recept. Hoist Cont. Box
J68	Recept. Disc. Muff Heater	J273	Recept. Hoist Cont. Pendant
J71	Recept. Engine Fuel Valve	J274	Recept. Hoist Boom Act.
J72	Recept. Engine Oil Press. Sw.	J275	Recept. Hoist Winch Assembly
J74	Recept. Battery Disc.	J1017	Recept. Ext. Fuel Disc. L/H
175	Recept. Navigation Lights Flasher	J1024	Recept. Ext. Fuel Disc. R/H
J77	Recept. Ice Detector	K1	Relay, Ext. Power
J80	Recept. Engine Air Filter Press. Sw.	K2	Relay, Non-Ess Bus
J81	Recept. Starter-Deck	K3	Relay, Starter
J84	Recept. De-Icing Hot Air Valve	K4	Relay, Bus Cont. (Gen Fail)
J85	Recept. Engine Oil Temp. Bulb	KS	Relay, Reverse Curr. (Main)
J86	Recept. Power Turbine Tach.	K6	Relay, Overvoltage
J87	Recept. Gas Turbine Tach.	K?	Relay, Gen Field
J89	Recept. Primer Valve (Fuel Ign. Sol.)	K8	Relay, AC Failure
J90	Recept. Fuel Cont. Sol. Valve	K9	Relay, Battery
J91	Recept. Engine Disc.	K10	Relay, Fuel Transfer
J92	Recept. Engine Forward Disc.	K15	Relay, Standby Gen Field
J93	Recept. Fire Det. Forward Disc.	K23	Relay, Standby Gen. Rev. Curr.
J94	Recept. Fire Det. Element R/H	K24	Relay, Cargo Hook Release
J95	Recept. Fire Det. Element L/H	K27	Relay, Inverter
J96	Recept. Fire Det. Element R/H	K32	Relay, Hoist Power
J97	Recept. Fire Det. Element L/H	K35	Relay, Main Invtr. Power
J98	Recept. Tail Light Disc.	K36	Relay, Spare Invtr. Power
J99	Recept. Thermocouple Disc.		

Table F-2. Equipment List - Helicopters Serial No. 66-746 Through 66-17144 (Cont)

ITEM NO.	DESCRIPTION	ITEM NO.	DESCRIPTION
P146	Plug, Bleed Air Valve	S25	Switch, Landing Lt. (Ext. Retr)
P147	Plug, Unshielded Tank Coupler Disc.	S26	Switch XMSN Oil Temp.
P148	Plug, Unshielded Tank Coupler Disc.	S27	Switch, Hydraulic Press.
P149	Plug, Unshielded Tank Coupler Disc.	S28	Switch, XMSN Oil Press. Warn.
P151	Plug, Shielded Tank Coupler Disc.	S29	Switch, Eng. Oil Press. Warn.
P152	Plug, Shielded Tank Coupler Disc.	S31	Switch, Limit (Ext. Pwr. Door)
P153	Plug, Shielded Tank Coupler Disc.	S32	Switch, Cargo Release (Pilot)
P155	Plug, Hi- Lo RPM Warning	S33	Switch, Gov. (Auto- Emer)
P156	Plug, Engine Fuel Filter Bypass	S35	⚠ Switch, Fwd. Dome Lt.
P166	Plug, Aft Outlet Valve	S36	Switch, Cargo Release
P191	Plug, Inverter Disc. - Main	S37	Switch, RPM Gov. (Pilot)
P192	Plug, Inverter Disc. - Spare	S38	Switch, fuel (ON-OFF)
P194	Plug, Engine Chip Detector	S39	Switch, Invtr (Main - Spare)
P268	Plug, Hoist to Ship	S40	Switch, Battery (ON-OFF)
P269	Plug, Cable, Out & Up Limit	S41	Switch, Upper Float
P270	Plug, Hoist to Cont. Pendant	S42	Switch, Lower Float
P271	Plug, Boom Act.	S44	Switch, Fuel - Low Level
P272	Plug, Hoist to Winch Assy	S45	Switch, Fuel - Transfer L/H
P273	Plug, Cont. Pendant	S46	Switch, Fuel - Transfer R/H
P274	Plug, Boom Act.	S49	Switch, J-2 Comp. De-slave
P275	Plug, Winch Assembly	S50	Switch, Idle Stop Rel. (Pilot)
P1017	Plug, Ext. Fuel Disc. L/H	S51	Switch, RPM Gov. (Copilot)
P1024	Plug, Ext. Fuel Disc. R/H	S58	Switch, Fuel Diff. Press.
PS1	Pilot, 5V Power Supply	S59	Switch, Anti- Coil. Light
PS2	Copilot, 5V Power Supply	S62	Switch, Non- Ess Bus Cont.
R1	Shunt, Ammeter (Stby Gen.)	S63	Switch, Ext. Fuel Jett.
R2	Shunt, Ammeter (Main Gen.)	S68	Switch, Force Trim
R3	Resistor - Windshield Wiper	S70	Switch, Starter Gen.
R4	Rheostat, Pilot Inst. Lt. Dim	S73	Switch, Overheat Bleed Air
R5	Rheostat, Sec. Inst. Lt. Dim	S75	Switch, Searchlight (ON-STOW)
R6	Rheostat, Overhead Console	S76	Switch, Landing Light (ON-OFF)
R7	Resistor, Navigation Lts. Dim	S77	Switch, Starter (Copilot Coil)
R8	Rheostat, Peal. Lights Dim	S78	Switch, Cargo Rel (Copilot)
R9	Rheostat, Engine Inst. Lights Dim	S79	Switch, Fuel Ejector Flow Sw. L/H
R10	Rheostat, Copilot Inst. Lights Dim	S80	Switch, Fuel Ejector Flow Sw. R/H
R11	Resistor, Fire Det. Cont.	S81	Switch. De-Ice (ON-OFF)
R12	Resistor, Spool Thermocouple	S83	Switch, Bleed Air (ON-OFF)
R21	Rheostat, Aft Dome Lts.	S84	⚠ Switch, Bleed Air (Ht-Def)
R26	Rheostat, Course Ind. Lt. Dim	S85	Switch, Aft Outlets (Htr)
R27	Resistor, AC Load Balancing	S87	Switch, Aft Outlet Limit
S1	Switch, Aft Dome Lt.	S88	⚠ Switch, Start Fuel
S2	Switch, Rotary (DC VM Sel)	S93	Switch, Hi- Lo RPM
S4	Switch, XMSN Sump Inspection Lt.	S94	Switch, Fuel Filter Bypass
S5	Switch, Fuel Qty. Test	S96	Switch, Cable Cut
S6	Switch, Starter (Pilot Coil)	S97	Switch, Cable Up Limit
S7	Switch, Hydraulic Boost Cont.	S101	Switch, Overload Sense
S8	Switch, Gen. (ON-OFF-RESET)	S111	Switch, Fuel Trans Pump
S9	Switch, Pitot Heater	S112	Switch, Pilot Hoist Cont.
S10	Switch, Force Trim (Copilot Cyc.)	S114	Switch, Fire Control
S11	Switch, Rotary (AC VM Sel)	S115	Switch, Fire Control
S12	Switch, Searchlight Cont.	S124	Switch, Sel- W/Wiper
S13	Switch, Nav. Lts. (Flash Steady)	S134	Switch, Chip Det. Sel
S14	Switch, Nav. Lts. (Bright-Dim)	S195	Switch, Diff. Press.
S18	Switch, Force Trim (Pilot Cyc.)	T1	Transformer 115/28V
S20	Switch, Test (Fire Det.)	RB1	Term. Blk. Fwd. Inst. Panel
S23	Switch, Windshield Wiper		

Table F-2. Equipment List - Helicopters Serial No. 66-746 Through 66-17144 (Cont)

ITEM NO.	DESCRIPTION	ITEM NO.	DESCRIPTION
TB 2	Term. Blk. Overhead Console R/H	W1	Cable Assembly
TB 3	Term. Blk. Overhead Console L/H	Z2	Engine, Ignition Unit
TB 4	Term. Blk. Aft Fuel Cell	Z3	Flasher Unit - Nav. Lts.
TB 9	Term. Blk. Top Ext. & Dome Lts.	Z5	XMSN Oil Temp. Bulb
TB 12	Term. Blk. Peal. Panel Edge Lts.	Z6	Engine Oil Temp. Bulb
TB 13	Term. Blk. Inst. Panel Lts.	Z8	Ice Interpreter
TB 14	Term. Blk. Inst. Panel Sec. Lts.	Z9	Fire Det. Cont.
TB 15	Term. Blk. Cockpit Lts L/H	Z13	Ice Detector
TB 16	Term. Blk. Cockpit Lts. R/H	Z16	Fuel Qty. Tank Unit - Aft
TB 25	Term. Blk. Thermocouple Ind.	Z17	Displacement - Roll * Pitch Gyro
TB 26	Term. Blk. DC Gnd & Audio	Z18	Rate Switching Gyro
TB 27	Term. Blk. Aft Thermo Lead	Z22	Fuel Qty. Tank Unit R/H Fwd.
TB 29	Term. Blk. Inst. Ground	Z24	Hoist Control Box
TB 34	Term. Blk. Aft Dome Lt. Panel	Z25	Hoist Cable Cutter
TB 35	Term. Blk. R/H Fuel Cell	Z41	Hoist Control Pendant
TB 36	Term. Blk. Ext. Power Diode		
TB 38	Term. Blk. Left-hand Fuel Cell		
TB 39	Term. Blk. Elec. Compt. Aft		
TB 45	Term. Blk. Pitot Heater - Disc.		
TB 60	Term. Blk. Battery Voltage, Fwd.		
TB 61	Term. Blk. Battery Voltage, Aft		
TB100	Term. Blk. Pilot and Copilot 5V Power Supply		
VR1	Regulator - Voltage (Main Gen)		
VR2	Regulator, Voltage (Stby Gen.)		
			NOTES
		⚠	EFF 66-16868 thru 66-17144
		⚠	EFF 66-746 through 66-16867
		⚠	EFF 66-746 through 66-1210, 66-16000 through 66-16033

Table F-2. Equipment List - Helicopters Serial No. 66-746 Through 66-17144 (Cont)

ITEM NO.	DESCRIPTION	ITEM NO.	DESCRIPTION
TB 2	Term. Blk. Overhead Console R/H	W1	Cable Assembly
TB 3	Term. Blk. Overhead Console L/H		
TB 4	Term. Blk. Aft Fuel Cell	Z2	Engine, Ignition Unit
TB 9	Term. Blk. Top Ext. & Dome Lts.	Z3	Flasher Unit - Nav. Lts.
TB 12	Term. Blk. Peal. Panel Edge Lts.	Z5	XMSN Oil Temp. Bulb
TB 13	Term. Blk. Inst. Panel Lts.	Z6	Engine Oil Temp. Bulb
TB 14	Term. Blk. Inst. Panel Sec. Lts.	Z8	Ice Interpreter
TB 15	Term. Blk. Cockpit Lts L/H	Z9	Fire Det. Cont.
TB 16	Term. Blk. Cockpit Lts. R/H	Z13	Ice Detector
TB 25	Term. Blk. Thermocouple Ind.	Z16	Fuel Qty. Tank Unit - Aft
TB 26	Term. Blk. DC Gnd & Audio	Z17	Displacement - Roll * Pitch Gyro
TB 27	Term. Blk. Aft Thermo Lead	Z18	Rate Switching Gyro
TB 29	Term. Blk. Inst. Ground	Z22	Fuel Qty. Tank Unit R/H Fwd.
TB 34	Term. Blk. Aft Dome Lt. Panel	Z24	Hoist Control Box
TB 35	Term. Blk. R/H Fuel Cell	Z25	Hoist Cable Cutter
TB 36	Term. Blk. Ext. Power Diode	Z41	Hoist Control Pendant
TB 38	Term. Blk. Left-hand Fuel Cell		
TB 39	Term. Blk. Elec. Compt. Aft		NOTES
TB 45	Term. Blk. Pitot Heater - Disc.		
TB 60	Term. Blk. Battery Voltage, Fwd.	A	EFF 66-16868 thru 66-17144
TB 61	Term. Blk. Battery Voltage, Aft		
TB100	Term. Blk. Pilot and Copilot 5V Power Supply	A	EFF 66-746 through 66-16867
VR1	Regulator - Voltage (Main Gen)		
VR2	Regulator, Voltage (Stby Gen.)	A	EFF 66-746 through 66-1210, 66-16000 through 66-16033

Table F-3. Equipment List - Helicopters Serial No. 67-17146 Through 67-19537

ITEM NO.	DESCRIPTION	ITEM NO.	DESCRIPTION
A1	Panel, DC Power	E1	Detector Magnetic Chip
A2	Panel, AC Power	E2	Detector Magnetic Chip
A3	Panel, Engine	E3	Detector, Magnetic Chip
A4	Panel, Caution	G2	Generator, 30VDC (300A)
A6	Panel, Instrument Lights	G3	Generator, Tach (Gas Prod)
A7	Panel, Ext. Lights	G4	Generator, Tach (Pwr Turb)
A8	Panel, Hydraulic Cont.	G5	Generator, Tach (Rotor)
A10	Panel, Miscellaneous	G6	Generator, Starter 28V (200A)
A11	Panel, Heating	HR1	Heater, Pitot Tube
A12	Cargo, Hook Assembly	I1	Indicator, Attitude (Copilot)
A13	Panel, Resistor	I2	Indicator, Fuel Qty.
A14	Panel, AC Circuit Breaker	I3	Indicator, Torque - Pilot
A15	Panel, Overhead Console	I4	Indicator, Oil Press (Eng)
A20	Panel Assembly Aft Dome Lights	I5	Indicator, Oil Press (XMSN)
A21	Panel, Dome Lt. & Pitot Heater	I6	Indicator, Fuel Press.
A26	Panel, Assembly Ext. Fuel	I7	Indicator, Tach (Gas Prod)
B1	Syncro XMTR, Torque Press.	I8	Indicator, Tach Dual (Pilot)
B2	Syncro XMTR, XMSN Oil Press.	I9	Light, Utility (Pilot)
B3	Syncro XMTR, Engine Oil Press.	I 10	Light, Dome
B4	Syncro XMTR, Fuel Press.	I11	Light, Search
B5	Motor, Fuel Shutoff Valve	I12	Light, Fire Warning
B6	Motor, R/H Fuel Boost Pump	I13	Light, Master Caution
B7	Motor, Windshield Wiper	I14	Light, Instr. Secondary
B8	Motor, R/H Aux. Fuel Pump	I15	Lamp, Instr. & Edge Lights
B12	Motor, Gov. RPM Actuator	I16	Light, Landing
B13	Motor, L/H Aux. Fuel Pump	I17	Light, Left Nav.
B22	Motor, Boom Actuator Hoist	I18	Light, Right Nav.
B31	Motor, Copilot Windshield Wiper	I19	Light, Tail
B35	Motor, Winch Assembly, Hoist	I 20	Light, Top Fuselage
B34	Motor, Bleed Air Valve	I21	Indicato, XMSN Oil Temp.
BT2	Battery	I22	Indicator, Eng. Oil Temp.
C1	Capacitor, PF Corr. (MIL-C-25)	I23	Indicator, Turn & Slip (Pilot)
C7	Capacitor Filter, JN14	I25	Light, XMSN Sump Inspect
CB1	Circuit Breaker (5A)	I26	Light, Bottom Fuselage
CB2	Circuit Breaker (10A)	I28	Light, Utility (Copilot)
CB3	Circuit Breaker (15A)	I31	Indicator, Exh. Temp. (Pilot)
CB4	Circuit Breaker (20A)	I34	Standby Compass (Pilot)
CB5	Circuit Breaker (25A)	I 40	Light, Anti- Collision
CB6	Circuit Breaker (1A)	I42	Indicator, Attitude (Pilot)
CB7	Circuit Breaker (35A)	I 44	Light, Cargo Release Armed
CB8	Circuit Breaker (2A)	I45	Light, Hi-Lo RPM Warn.
CB11	Circuit Breaker (7.5A)	J2	Recept. Pitot Tube Heater
CB12	Circuit Breaker (50A)	J3	Recept. Instrument Panel Disc.
CB13	Circuit Breaker (1A)	J4	Recept. Fuel Quantity Ind.
CP1	Coupler, Fuel Qty. Unshielded	J5	Recept. Fuel Press. Ind.
c P2	Coupler, Fuel Qty. Shielded	J6	Copilot Att. Ind.
CR2	Diode, Ext. Power Relay	J7	Recept. Engine Oil Temp. Ind.
CR30	Diode, Battery Voltage Fwd. Loc	J8	Recept. Engine Oil Press. Ind.
CR31	Diode, Battery Voltage, Aft Loc	J9	Recept. Pilot Dual Tach. Rotor
D1	Inverter (Main)	J10	Recept. Pilot Dual Tach. Pwr. Turb.
D2	Inverter (Spare)	J11	Recept. XMSN Oil Temp. Ind.
DS1	Control Assembly RPM Warn.	J12	Recept. XMSN Oil Press. Ind.
		J13	Recept. Pilot 5V Power Supply
		J14	Recept. Copilot 5V Power Supply

Table F-3. Equipment List - Helicopters Serial No. 67-17145 Through 67-19637 (Cont)

ITEM NO.	DESCRIPTION	ITEM	DESCRIPTION
K66	Relay, Battery Feeder		
L1	Solenoid, Primer (Ignition)	P47	Plug, Fuel Tank Disc. R/H Cell
L2	Solenoid, Fuel Cont. Valve	P48	Plug, Fuel Tank Disc. R/H Cell
L4	Solenoid, Hydraulic Bypass	P53	Plug, Unshld Tank Unit - Aft Cell
L46	Solenoid, Hot-Air De-Ice	P54	Plug, Shld Tank Unit - Aft Cell
L?	Solenoid, Idle Stop Rel.	P55	Plug, Fuel Tank Disc - Aft Cell
L8	Msg. Brake - Anti-Torque Force Trim	P56	Plug, Fuel Tank Disc - Aft Cell
L9	Msg. Brake - Fore & Aft Force Trim	P57	Plug, Ext. Fuel Cont. Panel
L10	Msg. Brake - Lat. Force Trim	P60	Plug, Field Relay Gen.
L14	Solenoid, Door Post Aft Outlet Valve	P64	Plug, Torque Press. XMTR
L15	Solenoid, Aft Outlet Valve Act.	P65	Plug, Engine Oil Press. XMTR
L21	Solenoid, Var. Mix Valve	P66	Plug, Fuel Press. XMTR
M1	Meter, DC Load (St-by Gen.)	P68	Plug, Muff Heater Disc.
M2	Meter, DC Volts	P71	Plug, Fuel Valve Shut- off
M3	Meter, AC Volts	P72	Plug, Eng. Oil Press. Sw.
M4	Meter, DC Load (Main Gen.)	P74	Plug, Battery Disc. Fwd.
02	Guard-Gen. Sw. - DC Pwr. Panel	P75	Plug, Nav. Lts. Flasher
03	Guard-Cable Cut Sw. - Hyd Panel	P77	Plug, Ice Detector
P2	Plug, Pltot Tube Htr.	P 80	Plug, Eng. Air Filter Press. Sw.
P3	Plug, Inst. Panel Corm.	P81	Plug* Starter Deck
P4	Plug, Fuel Qty. Ind.	P 84	Plug, De-icing Hot Air Valve
P5	Plug, Fuel Press. Ind.	P85	Plug, Oil Temp. Bulb
P6	Plug, copilot Att. Ind.	P 86	Plug, Pwr. Turb. Tach.
P7	Plug, Eng. Oil Temp. Ind.	P87	Plug, Gas Prod. Tach.
P8	Plug, Eng. Oil Press. Ind.	P88	Plug, Ignition Unit - Engine
P9	Plug, Pilot Dual Tach. (Rotor)	P89	Plug, Ignition Sol. Valve
P10	Plug, Pilot Dual Tach. (Pwr Turb.)	P 90	Plug, Fuel Cont. Sol. Valve
P11	Plug, XMSN Oil Temp. Ind.	P91	Plug, Engine Disc.
P12	Plug, XMSN Oil Press. Ind.	P92	Plug, Engine Forward Disc.
P13	Plug, Pilot 5V Power Supply	P93	Plug, Fire Det. Forward Disc.
P14	Plug, Copilot 5V power Supply	P94	Plug, Fire Det. Element R/H
P15	Plug, Pilot Torque Meter	P95	Plug, Fire Det. Element L/H
P16	Plug, Pilot Turn & Slip Ind.	P 96	Plug, Fire Det. Element R/H
P17	Plug, Gas Prod. Turb. Tach.	P97	Plug, Fire Det. Element L/H
P20	Plug, Pilot's Cyclic Stick	P98	Plug, Tail Light Disc.
P21	Plug, Hydraulic Cont. Panel	P99A	Plug, Thermocouple Disc. Engine
P22	Plug, Copilot Cyclic Stick	P99B	Plug, Thermocouple Disc. Engine
P23	Plug, Engine Panel	P102	Plug, Standby Compass (Pilot)
P24	Plug, Caution Panel	P107	Plug, Copilot Coil. Stick
P25	Plug, Pilot Coil. Stick	P108	Plug, Fuel Diff. Press. Sw.
P26	Plug, Windshield Wiper	P110	Plug, Anti-Coil. Lt. Disc.
P28	Plug, Hyd. Bypass Solenoid Valve	Pi11	Plug, Anti- Coil. Lt.
P29	Plug, Hyd. Press. Warning Sw.	P112	Plug, Msg. Brake Anti-Torque
P31	Plug, Cargo Hook	P113	Plug, Msg. Brake Fore & Aft
P32	Plug, Cargo Hook Disc.	P114	Plug, Msg. Brake - Lat.
P35	Plug, Rotor Tach. Gen.	P119	Plug, Cabin Roof Disc. Hoist
P36	Plug, XMSN Oil Press. Sw.	P127	Plug, Var. Mix Valve Disc.
P37	Plug, XMSN Oil Temp. Bulb	P129	Plug, Displacement, Roll & Pitch Gyro
P38	Plug, Copilot W/S Wiper	P130	Plug, Rate Switching Gyro
P39	Plug, XMSN Oil Press. XMTR	P131	Plug, Attitude Ind.
P41	Plug, XMSN Disc.	P135	Plug, Ice Interpreter
P42	Plug, Shielded Tank Unit Disc (R/H Tank)	P136	Plug, Ice Interpreter
P43	Plug, Monitor Tank Unit Disc (R/H Tank)	P138	Plug, Door Post - Aft-Out Val. Act.
P44	Plug, Unshielded Tank Unit Disc (R/H Tank)	P146	Plug, Bleed Air Valve
P46	Plug, Fuel Tank Disc R/H Cell	P147	Plug, Unshld-Tank Coupler Disc.

Table F-3. Equipment List - Helicopters Serial No. 67-17145 Through 67-19637 (Cont)

ITEM NO.	DESCRIPTION	ITEM	DESCRIPTION
K66	Relay, Battery Feeder		
L1	Solenoid, Primer (Ignition)	P47	Plug, Fuel Tank Disc. R/H Cell
L2	Solenoid, Fuel Cont. Valve	P48	Plug, Fuel Tank Disc. R/H Cell
L4	Solenoid, Hydraulic Bypass	P53	Plug, Unshld Tank Unit - Aft Cell
L46	Solenoid, Hot-Air De-Ice	P54	Plug, Shld Tank Unit - Aft Cell
L?	Solenoid, Idle Stop Rel.	P55	Plug, Fuel Tank Disc - Aft Cell
L8	Msg. Brake - Anti-Torque Force Trim	P56	Plug, Fuel Tank Disc - Aft Cell
L9	Msg. Brake - Fore & Aft Force Trim	P57	Plug, Ext. Fuel Cont. Panel
L10	Msg. Brake - Lat. Force Trim	P60	Plug, Field Relay Gen.
L14	Solenoid, Door Post Aft Outlet Valve	P64	Plug, Torque Press. XMTR
L15	Solenoid, Aft Outlet Valve Act.	P65	Plug, Engine Oil Press. XMTR
L21	Solenoid, Var. Mix Valve	P66	Plug, Fuel Press. XMTR
M1	Meter, DC Load (St-by Gen.)	P68	Plug, Muff Heater Disc.
M2	Meter, DC Volts	P71	Plug, Fuel Valve Shut- off
M3	Meter, AC Volts	P72	Plug, Eng. Oil Press. Sw.
M4	Meter, DC Load (Main Gen.)	P74	Plug, Battery Disc. Fwd.
02	Guard-Gen. Sw. - DC Pwr. Panel	P75	Plug, Nav. Lts. Flasher
03	Guard-Cable Cut Sw. - Hyd Panel	P77	Plug, Ice Detector
P2	Plug, Pltot Tube Htr.	P 80	Plug, Eng. Air Filter Press. Sw.
P3	Plug, Inst. Panel Corm.	P81	Plug* Starter Deck
P4	Plug, Fuel Qty. Ind.	P 84	Plug, De-icing Hot Air Valve
P5	Plug, Fuel Press. Ind.	P85	Plug, Oil Temp. Bulb
P6	Plug, copilot Att. Ind.	P 86	Plug, Pwr. Turb. Tach.
P?	Plug, Eng. Oil Temp. Ind.	P87	Plug, Gas Prod. Tach.
P8	Plug, Eng. Oil Press. Ind.	P88	Plug, Ignition Unit - Engine
P9	Plug, Pilot Dual Tach. (Rotor)	P89	Plug, Ignition Sol. Valve
P10	Plug, Pilot Dual Tach. (Pwr Turb.)	P 90	Plug, Fuel Cont. Sol. Valve
P11	Plug, XMSN Oil Temp. Ind.	P91	Plug, Engine Disc.
P12	Plug, XMSN Oil Press. Ind.	P92	Plug, Engine Forward Disc.
P13	Plug, Pilot 5V Power Supply	P93	Plug, Fire Det. Forward Disc.
P14	Plug, Copilot 5V power Supply	P94	Plug, Fire Det. Element R/H
P15	Plug, Pilot Torque Meter	P95	Plug, Fire Det. Element L/H
P16	Plug, Pilot Turn & Slip Ind.	P 96	Plug, Fire Det. Element R/H
P17	Plug, Gas Prod. Turb. Tach.	P97	Plug, Fire Det. Element L/H
P20	Plug, Pilot's Cyclic Stick	P98	Plug, Tail Light Disc.
P21	Plug, Hydraulic Cont. Panel	P99A	Plug, Thermocouple Disc. Engine
P22	Plug, Copilot Cyclic Stick	P99B	Plug, Thermocouple Disc. Engine
P23	Plug, Engine Panel	P102	Plug, Standby Compass (Pilot)
P24	Plug, Caution Panel	P107	Plug, Copilot Coil. Stick
P25	Plug, Pilot Coil. Stick	P108	Plug, Fuel Diff. Press. Sw.
P26	Plug, Windshield Wiper	P110	Plug, Anti-Coil. Lt. Disc.
P28	Plug, Hyd. Bypass Solenoid Valve	Pi11	Plug, Anti- Coil. Lt.
P29	Plug, Hyd. Press. Warning Sw.	P112	Plug, Msg. Brake Anti-Torque
P31	Plug, Cargo Hook	P113	Plug, Msg. Brake Fore & Aft
P32	Plug, Cargo Hook Disc.	P114	Plug, Msg. Brake - Lat.
P35	Plug, Rotor Tach. Gen.	P119	Plug, Cabin Roof Disc. Hoist
P36	Plug, XMSN Oil Press. Sw.	P127	Plug, Var. Mix Valve Disc.
P37	Plug, XMSN Oil Temp. Bulb	P129	Plug, Displacement, Roll & Pitch Gyro
P38	Plug, Copilot W/S Wiper	P130	Plug, Rate Switching Gyro
P39	Plug, XMSN Oil Press. XMTR	P131	Plug, Attitude Ind.
P41	Plug, XMSN Disc.	P135	Plug, Ice Interpreter
P42	Plug, Shielded Tank Unit Disc (R/H Tank)	P136	Plug, Ice Interpreter
P43	Plug, Monitor Tank Unit Disc (R/H Tank)	P138	Plug, Door Post - Aft-Out Val. Act.
P44	Plug, Unshielded Tank Unit Disc (R/H Tank)	P146	Plug, Bleed Air Valve
P46	Plug, Fuel Tank Disc R/H Cell	P147	Plug, Unshld-Tank Coupler Disc.

Table F-3. Equipment List - Helicopters Serial No. 67-17145 Through 67-19537 (Cont)

ITEM NO.	DESCRIPTION	ITEM NO.	DESCRIPTION
P148	Plug, Unshld-Tank Coupler Disc.	S27	Switch, Hyd. Press.
P149	Plug, Unshld-Tank Coupler Disc.	S28	Switch, XMSN Oil Press. Warning
P151	Plug, Shld-Tank Coupler Disc.	S29	Switch, Eng. Oil Press. Warning
P152	Plug, Shld-Tank Coupler Disc.	S31	Switch, Limit (Ext. Pwr. Door)
P153	Plug, Shld-Tank Coupler DISC.	S32	Switch, Cargo Release (Pit)
P155	Plug, Hi-Lo RPM Warning	S33	Switch, Gov. (Auto- Emer)
P156	Plug, Eng. Fuel Filter Bypass	S39	Switch, Invtr. (Main-Spare)
P166	Plug, Aft Outlet Valve	S36	Switch, Cargo Release
P191	Plug, Inverter Disc. - Main	S37	Switch, RPM Gov. (Pit)
P192	Plug, Inverter Disc. - Spare	S38	Switch, Fuel (ON-OFF)
P194	Plug, Engine Chip Detector	S40	Switch, Battery (ON-OFF)
P267	Plug, Battery Disc. Aft	S41	Switch, Upper Float
P268	Plug, Hoist to Ship	S42	Switch, Lower Float
P269	Plug, Cable Cut & Slip Limit	S44	Switch, Fuel - Low Level
P270	Plug, Hoist to Cont. Pendant	S45	Switch, Fuel - Transfer L/H
P271	Plug, Boom Act.	S46	Switch, Fuel - Transfer R/H
P272	Plug, Hoist to Winch Assy.	S47	Switch, ICS Sw. Pilot's Cyclic Stick
P273	Plug, Cont. Pendant	S48	Switch, KS SW Copilot's Cyclic Stick
P274	Plug, Boom Act.	S50	Switch, Idle Stop Rel (Pit)
P275	Plug, Winch Assy	S51	Switch, RPM Gov. (Copilot)
P1017	Plug, Ext. Fuel Disc. L/H	S58	Switch, Fuel Diff. Press.
P1024	Plug, Ext. Fuel Disc. R/H	S59	Switch, Anti-Coil. Lt.
PS1	Pilot 5V Power Supply (PS-274B)	S62	Switch, Non- Ess Bus Cont.
PS2	Copilot 5V Power Supply (PS-274B)	S63	Switch, Ext. Fuel Jett.
R1	Shunt-Ammeter (Stby Gen.)	S68	Switch, Force Trim
R2	Shunt-Ammeter (Main Gen.)	S70	Switch, Starter-Gen.
R3	Resistor-Windshield Wiper	S73	Switch, Overheat Bleed Air
R4	Rheostat, Plt Inst. Lt. Dim	S77	Switch, Searchlight (ON-STOW)
R5	Rheostat, Sec. Inst. Lt. Dim	S76	Switch, Landing Lt. (ON-OFF)
R6	Rheostat, Overhead Console	S77	Switch, Starter (Copilot Coil)
R7	Resistor, Nav. Lts. Dim	S78	Switch, Cargo Rel (Copilot)
R8	Rheostat, Peal. Lts. Dim	S79	Switch, Fuel Ejector Flow Sw. L/H
R9	Rheostat, Eng. Inst. Lts. Dim	S 80	Switch, Fuel Ejector Flow Sw. R/H
R10	Rheostat, Copilot Inst. Lts. Dim	S81	Switch, De-Ice (ON-OFF)
R11	Resistor, Fire Det. Cont.	S83	Switch, Bleed Air (ON-OFF)
R12	Resistor, Spool Thermocouple	S85	Switch, Aft Outlets (Htr)
R21	Rheostat, Aft Dome Lts.	S87	Switch, Aft-Outlet, Limit
R26	Rheostat, Course Ind. Lt. Dim	S93	Switch, Hi- Lo RPM
R27	Resistor, AC Load Balancing	S94	Switch, Fuel Filter Bypass
S1	Switch, Aft Dome Lt.	S 96	Switch, Cable Cut
S2	Switch, Rotary (DC VM Sel)	S97	Switch, Cable Up Limit
S4	Switch, XMSN Sump Insp. Lt.	S101	Switch, Overload Sense
S5	Switch, Fuel Qty Test	S111	Switch, Fuel Trans. Pump
S6	Switch, Starter (Pit Coil)	S112	Switch, Pilot Hoist Cont.
S7	Switch, Hyd Boost Cont.	S114	Switch, Fire Control
S8	Switch, Gen. (On-Off Reset)	S115	Switch, Fire Control
S9	Switch, Pitot Heater	S124	Switch, Sel - W/Wiper
S10	Switch, Force Trim (Copilot Sw.)	S134	Switch, Chip Det. Sel.
S12	Switch, Searchlight Cont.	S195	Switch, Diff. Press.
S13	Switch, Nav. Lts. (Flash Steady)		
S14	Switch, Nav. Lts. (Bright-Dim)	T1	Transformer 115/28V
S.8	Switch, Force Trim (Pit- Cyl)	TB1	Term. Blk. Fwd. Inst. Panel
S20	Switch, Test (Fire Det.)	T B2	Term. Blk. Overhead Console R/H
S23	Switch, Windshield Wiper	T B3	Term. Blk. Overhead Console L/H
S25	Switch, Landing Lt. (Ext-Retr)	T B4	Term. Blk. Aft Fuel Cell
S26	Switch, XMSN Oil Temp.	TB99	Term. Blk. Top Ext. & Dome Lts.



Table F-4. Equipment List - Helicopters Serial No. 68-15214 and Subsequent (Cont)

ITEM NO.	DESCRIPTION	ITEM No.	DESCRIPTION
TB12	Term. Blk. Peal. Panel Edge Lts.	VR1	Regulator - Voltage (Main Gen)
TB13	Term. Blk. Inst. Panel Lts.	VR2	Regulator - Voltage (Stby Gen)
TB14	Term. Blk. Inst. Panel Sec. Lts.		
TB15	Term. Blk. Cockpit Lts. L/H	W1	Cable Assembly - Fire Det.
TB16	Term. Blk. Cockpit Lts. R/H		
TB22	Term. Blk. Copilot Headset	Z2	Engine, Ignition Unit
TB23	Term. Blk. Pilot Headset	Z3	Flasher Unit - Nav. Lts.
TB25	Term. Blk. Thermocouple Ind.	Z5	XMSN Oil Temp. Bulb
TB26	Term. Blk. DC Grid. & Audio	Z6	Engine Oil Temp. Bulb
TB27	Term. Blk. Aft Thermo Lead	Z8	Ice Interpreter
TB29	Term. Blk. Inst. Ground	Z9	Fire Det. Cont.
TB34	Term. Blk. Aft Dome Lt. Panel	Z13	Ice Detector
TB35	Term. Blk. R/H Fuel Cell	Z16	Fuel Qty. Tank Unit - Aft
TB36	Term. Blk. Ext. Power Diode	Z17	Displacement - Roll & Pitch Gyro
TB38	Term. Blk. L/H Fuel Cell	Z18	Rate Switching <i>Gyro</i>
TB39	Term. Blk. Elect. Compt. Aft	Z22	Fuel Qty. Tank Unit R/H Fwd.
TB45	Term. Blk. Pitot Htr. - Disc.	Z24	Hoist Control Box
TB60	Term. Blk. Battery Voltage, Fwd.	Z25	Hoist Cable Cutter
TB61	Term. Blk. Battery Voltage, Aft	Z41	Hoist Control Pendant
TB100	Term, Blk. Pilot and Copilot 5V Power Supply		

Table F-4. Equipment List - Helicopters Serial No. 68-16214 and Subsequent

ITEM NO.	DESCRIPTION	ITEM NO.	DESCRIPTION
A1	Panel, DC Power	E3	Detector, Magnetic Chip
A2	Panel, AC Power	E4	Detector, Magnetic Chip
A3	Panel, Engine		
A4	Panel, Caution	G2	Generator, 30 VDC (300A)
A6	Panel, Inst. Lights	G3	Generator, Tach (Gas Prod)
A7	Panel, Ext. Lights	G4	Generator, Tach (Pwr Turb)
A8	Panel, Hydraulic Control	G5	Generator, Tach (Rotor)
A10	Panel, Miscellaneous	G6	Generator, Starter 28 V (200A)
A11	Panel, Heating		
A12	Cargo Hook Assy	HR1	Heater, Pitot Tube
A13	Panel, Resistor		
A14	Panel, AC Circuit Breaker	I1	Indicator, Attitude (Copilot)
A15	Panel, Overhead Console	I2	Indicator, Fuel Qty
A20	Panel Assy, Aft Dome Lts	I3	Indicator, Torque - Pilot
A21	Panel, Dome Lt & Pitot Htr	I4	Indicator, Oil Press (Eng)
A26	Panel Assy, Ext. Fuel	I5	Indicator, Oil Press (XMSN)
		I6	Indicator, Fuel Press
B1	Syncro XMTR, Torque Press	I7	Indicator, Tach (Gas Prod)
B2	Syncro XMTR, XMSN Oil Press	I8	Indicator, Tach-Dual
B3	Syncro, XMTR Engine Oil Press	I9	Light, Utility (Pilot)
B4	Syncro XMTR, Fuel Press	I10	Light, Dome
B5	Motor, Fuel Shut-Off Valve	I11	Light, Search
B6	Motor, R/H Fuel Boost Pump	I12	Light, Fire Warning
B7	Motor, Windshield Wiper	I13	Light, Master Caution
B8	Motor, R/H Aux. Fuel Pump	I14	Light, Instr, Secondary
B12	Motor, Gov RPM Actuator	I15	Lamp, Instr & Edge Lights
B13	Motor, L/H Aux. Fuel Pump	I16	Light, Landing
B31	Motor, Copilot Windshield Wiper	I17	Light, Left Nav.
B34	Motor, Bleed Air Valve	I18	Light, Right Nav.
BT2	Battery	I19	Light, Tail
		I20	Light, Top Fuselage
C1	Capacitor, PF Corr. (MIL-C-25)	I21	Indicator, XMSN Oil Temp
C7	Capacitor, Filter, JN14	I22	Indicator, Eng. Oil Temp.
CB1	Circuit Breaker (5A)	I23	Indicator, Turn & Slip (Pit)
C B2	Circuit Breaker (10A)	I25	Light, XMSN Sump Inspect
CB3	Circuit Breaker (15A)	I26	Light, Bottom Fuselage
CB4	Circuit Breaker (20A)	I28	Light, Utility (Copilot)
CB5	Circuit Breaker (25A)	I31	Indicator, Exh. Temp (Pit)
CB6	Circuit Breaker (1A)	I34	Standby Compass (Pit)
CB7	Circuit Breaker (35A)	I40	Light, Anti- Collision
CB8	Circuit Breaker (2A)	I42	Indicator, Attitude (Pit)
CB11	Circuit Breaker (7.5A)	I44	Light, Cargo Release Armed
CB12	Circuit Breaker (50A)	I45	Light, Hi-Lo RPM Warn.
CB13	Circuit Breaker (1A)	I46	Light, Utility - Crew Pos 1
CP1	Coupler, Fuel Qty. Unshielded	I47	Light, Utility - Crew Pos 2
CP2	Coupler, Fuel Qty. Shielded	I48	Light, Utility - Crew Pos 3
CR2	Diode, Ext. Pwr. Relay		
CR30	Diode, Batt. Voltage Fwd Loc		
CR31	Diode, Batt. Voltage Aft Loc		
D1	Inverter, 250V.A. 3 Ph (Main)		
D2	Inverter, 250V.A. 3 Ph (Spare)		
DS1	Control Assy, RPM Warn.		
E1	Detector, Magnetic Chip		
E2	Detector, Magnetic Chip		



Table F-4. Equipment List - Helicopters Serial No. 68-15214 and Subsequent (Cont)

ITEM NO.	DESCRIPTION	ITEM NO.	DESCRIPTION
J2	Recept. Pitot Tube Htr		
J3	Recept. Instr. Panel Disc.		
J4	Recept. Fuel Qty Ind.		
J5	Recept. Fuel Press Ind.		
J6	Recept. Copilot Att. Ind.		
J7	Recept. Eng. Oil Temp. Ind.		
J8	Recept. Eng. Oil Press. Ind.		
J9	Recept. Pilot Dual Tach Rotor		
J10	Recept. Pilot Dual Tach Pwr Turb.		
J11	Recept. XMSN Oil Temp. Ind.		
J12	Recept. XMSN 011 Press. Ind.		
J13	Recept. Pilot 5V Power Supply		
J14	Recept. Copilot 5V Power Supply		
J15	Recept. Pilot Torque Meter		

Table F-4 Equipment List - Helicopters Serial No. 68-15214 and Subsequent (Cont)

ITEM NO.	DESCRIPTION	ITEM NO.	DESCRIPTION
J16	Recept. Pilot Turn & Slip Ind.	J107	Recept. Copilot Coil. Stick
J17	Recept. Gas Prod. Tach.	J108	Recept. Fuel Diff. Press. Sw.
J20	Recept. Pilot Cyclic Stick	J109	Recept. Ext. Power
J21	Recept. Hydraulic Cont. Panel	J110	Recept. Anti-Coil. Lt. Disc.
J22	Recept. Copilot Cyclic Stick	J11	Recept. Anti-Coil. Lt.
J23	Recept. Engine Panel	J112	Recept. Msg. Brake Anti-Torque
J24	Recept. Caution Panel	J113	Recept. Msg. Brake Fore & Aft
J25	Recept. Pilot Coil. Stick	J114	Recept. Msg. Brake Lat
J26	Recept. Windshield Wiper	J115	Recept. Test- Eng. Vibration Meter
J28	Recept. Hyd. Bypass Solenoid	J127	Recept. Var. Mix Valve Disc.
J29	Recept. Hyd. Press. Warn. Sw.	J129	Recept. Displacement-Roll & Pitch Gyro
J31	Recept. Cargo Hook	J130	Recept. Rate Switching Gyro
J32	Recept. Cargo Slind Disc.	J131	Recept. Attitude Ind.
J35	Recept. Rotor, Tach. Gen.	J135	Recept. Ice Interpreter
J36	Recept. XMSN Oil Press. Sw.	J136	Recept. Ice Interpreter
J37	Recept. XMSN Oil Temp. Bulb	J138	Recept. Door Post Outlet Valve Act
J38	Recept. Copilot Windshield Wiper	J146	Recept. Bleed Air Valve
J39	Recept. XMSN Oil Press. XMTR	J147	Recept. Internal Aux. Fuel Disc L/H
J41	Recept. XMSN Disc.	J148	Recept. Internal Aux. Fuel Disc R/H
J42	Recept. Fuel Tank Disc R/H	J155	Recept. Hi-Lo RPM Warn.
J43	Recept. Compensator Fuel Tank Disc R/H	J156	Recept. Eng. Fuel Filter Bypass Sw.
J44	Recept. Fuel Tank Disc R/H	J166	Recept. Aft, Outlet Valve
J53	Recept. Bulkhead Feed-thru-aft Fuel Cell	J191	Recept. Main Inverter Pwr.
J54	Recept. Bulkhead Feed- thru- aft Fuel Cell	J192	Recept. Spare Inverter Pwr.
J57	Recept. Ext. Fuel Cont. Panel	J194	Recept. Engine Chip Detector
J60	Recept. Socket, Relay-Gen. Field	J267	Recept. Battery Disc. Aft
J64	Recept. Torque Press. XMTR	J1017	Recept. Ext. Fuel Disc. L/H
J65	Recept. Eng. Oil Press. XMTR	J1024	Recept. Ext. Fuel Disc. R/H
J66	Recept. Fuel Press. XMTR		
J68	Recept. Disc. Muff Heater	K1	Relay, Ext. Pwr.
J71	Recept. Eng. Fuel Valve	K2	Relay, Non- Ess Bus
J72	Recept. Eng. Oil Press. Sw.	K3	Relay, Starter
J74	Recept. Batt. Disc. Fwd.	K4	Relay, Bus Cont. (Gen Fail)
J75	Recept. Nav. Lts. Flasher	K5	Relay, Reverse Curr. (Main)
J77	Recept. Ice Detector	K6	Relay, Overvoltage
J80	Recept. Eng. Air Filter Press. Sw.	K7	Relay, Gen. Field
J81	Recept. Starter Deck	K8	Relay, AC Failure
J 84	Recept. De-Icing Hot Air Valve	K9	Relay, Battery
J85	Recept. Eng. Oil Temp. Bulb	K10	Relay, Fuel Transfer
J 86	Recept. Pwr. Turb. Tach.	K15	Relay, Standby Gen. Field
J87	Recept. Gas Turb. Tach.	K23	Relay, Standby Gen. Rev. Curr.
J88	Recept. Ignition Unit, Eng.	K24	Relay, Cargo Hook Release
J89	Recept. Primer Valve (Fuel Ign. Sol.)	K27	Relay, Inverter
J 90	Recept. Fuel Cont. Sol. Valve	K35	Relay, Main Invtr. Pwr;
J91	Recept. Engine Disc.	K36	Relay, Spare Invtr. Pwr.
J92	Recept. Engine Fwd. Disc.	K37	Relay, Lo- Fuel Caution Lt.
J93	Recept. Fire Det. Fwd. Disc.	K28	Relay, Lo- Fuel Caution Lt.
J94	Recept. Fire Det. Element R/H	K46	Relay, Overheat
J95	Recept. Fire Det. Element L/H	K65	Relay, Battery, Aft Loc
J96	Recept. Fire Det. Element R/H	K66	Relay, Battery Feeder
J97	Recept. Fire Det. Element L/H		
J98	Recept. Tail Lt. Disc.	L1	Solenoid, Primer (Ignition)
J99	Recept. Thermocouple Disc.	L2	Solenoid, Fuel Cont. Valve
J102	Recept. Standby Compass (Pit)	L4	Solenoid, Hyd. Bypass
J105	Recept. Heated Blanket L/H	L6	Solenoid, Hot-Air De-icer
J106	Recept. Heated Blanket R/H	L7	Solenoid, Idle Stop Rel.

Table F-4. Equipment List - Helicopters Serial No. 68-15214 and Subsequent (Cont)

ITEM NO.	DESCRIPTION	ITEM NO.	DESCRIPTION
L8	Msg. Brake - Anti-Torque Force Trim	P64	Plug, Torque Press. XMTR
L9	Msg. Brake - F & A Force Trim	P65	Plug, Eng. Oil Press. XMTR
L10	Msg. Brake - Lat Force Trim	P66	Plug, Fuel Press XMTR
L14	Solenoid, Door Post Htr. Outlet Valve	P68	Plug, Muff Heater Disc.
L15	Solenoid, Aft Outlet Valve Act.	P71	Plug, Fuel Valve Shut-Off
L21	Solenoid, Var. Mix Valve	P72	Plug, Eng. Oil Press Sw.
M1	Meter, DC Load (Stand-by-gen.)	P74	Plug, Battery Disc. Fwd.
M2	Meter, PC Volts	P75	Plug, Nav. Lts. Flasher
M3	Meter, AC Volts	P77	Plug, Ice Detector
M4	Meter, DC Load (Main Gen)	P80	Plug, Eng. Air Filter Press. Sw.
O2	Guard - Gen. Sw. DC Pwr. Panel	P81	Plug, Starter Deck
P2	Plug, Pitot Tube Heater	P84	Plug, De-Icing Hot Air Valve
P3	Plug, Inst. Panel Corm.	P85	Plug, Oil Temp. Bulb
P4	Plug, Fuel Qty Ind.	P 86	Plug, Pwr. Turb. Tach.
P5	Plug, Fuel Press Ind.	P87	Plug, Gas Prod. Tach.
P6	Plug, Copilot Att. Ind.	P88	Plug, Ignition Unit- Eng.
P7	Plug, Engine Oil Temp. Ind.	P89	Plug, Ignition Sol. Valve
P8	Plug, Engine Oil Press. Ind.	P90	Plug, Fuel Cont. Sol Valve
P9	Plug, Pilot Dual Tach. Rotor	P91	Plug, Engine Disc.
P10	Plug, Pilot Dual Tach. (Pwr. Turb.)	P92	Plug, Engine Fwd. Disc.
P11	Plug, XMSN Oil Temp. Ind.	P93	Plug, Fire Det. Fwd. Disc.
P12	Plug, XMSN Oil Press. Ind.	P94	Plug, Fire Det. Element R/H
P13	Plug, Pilot 5v Power Supply	P95	Plug, Fire Det. Element L/H
P14	Plug, Copilot 5V Power Supply	P96	Plug, Fire Dec. Element R/H
P15	Plug, Pilot Torque Meter	P97	Plug, Fire Det. Element L/H
P16	Plug, Pilot Turn & Slip Ind.	P98	Plug, Tail Lt. Disc.
P17	Plug, Gas Prod. Turb. Tach.	P99A	Plug, Thermocouple Disc - Eng.
P20	Plug, Pilot's Cyclic Stick	P99B	Plug, Thermocouple Disc - Eng.
P21	Plug, Hyd. Cont. Panel	P102	Plug, Standby Compass (Pilot)
P22	Plug, Copilot Cyclic Stick	P107	Plug, Copilot Coil. Stick
P23	Plug, Engine Panel	P108	Plug, Fuel Diff. Press. Sw.
P24	Plug, Caution Panel	P110	Plug, Anti- Coil. Lt. Disc.
P25	Plug, Pilot Coil. Stick	P111	Plug, Anti- Coil. Lt.
P26	Plug, Windshield Wiper	P112	Plug, Msg. Brake Anti- Torque
P28	Plug, Hyd. Bypass Sol. Valve	P113	Plug, Msg. Brake F & A
P29	Plug, Hyd. Press. Warn. Sw.	P114	Plug, Msg. Brake - Lat.
P31	Plug, Cargo Hook	P127	Plug, Var. Mix Valve Disc.
P32	Plug, Cargo Hook Disc.	P129	Plug, Displacement, Roll & Pitch Gyro
P35	Plug, Rotor Tach. Gen.	P130	Plug, Rate Switching Gyro
P36	Plug, XMSN Oil Press. Sw.	P131	Plug, Attitude Ind.
P37	Plug, XMSN Oil Temp. Bulb	P135	Plug, Ice Interpreter
P38	Plug, Copilot Windshield Wiper	P136	Plug, Ice Interpreter
P39	Plug, XMSN Oil Press. XMTR	P138	Plug, Door Post-Aft Outlet Valve Act.
P41	Plug, XMSN Disc.	P146	Plug, Bleed Air Valve
P 42	Plug, Shielded Tank Unit Disc(R/H Tank)	P147	Plug, Unshielded Tank Coupler Disc.
P43	Plug, Monitor Tank Unit Disc(R/H Tank)	P148	Plug, Unshielded Tank Coupler Disc.
P44	Plug, Unshielded Tank Unit Disc(R/H Tank)	P149	Plug, Unshielded Tank Coupler Disc.
P46	Plug, Fuel Tank Disc. R/H Cell	P151	Plug, Shielded Tank Coupler Disc.
P47	Plug, Fuel Tank Disc R/H Cell	P152	Plug, Shielded Tank Coupler Disc.
P48	Plug, Fuel Tank Disc R/H Cell	P153	Plug, Shielded Tank Coupler Disc.
P53	Plug, Unshielded Tank Unit-Aft Cell	P155	Plug, Hi- Lo RPM Warning
P54	Plug, Shielded Tank Unit-Aft Cell	P156	Plug, Eng. Fuel Filter Bypass
P55	Plug, Fuel Tank Disc - Aft Cell	P166	Plug, Aft Outlet Valve
P56	Plug, Fuel Tank Disc - Aft Cell	P191	Plug, Inverter Disc. - Main
P57	Plug, Ext. Fuel Cont. Panel	P192	Plug, Inverter Disc. - Spare
P60	Plug, Field Relay Generator	P194	Plug, Eng. Chip Detector

Table F-4. Equipment List - Helicopters Serial No. 68-16214 and Subsequent (Cont)

TEM NO.	DESCRIPTION	ITEM NO.	DESCRIPTION
PZ67	Plug, Battery Disc. Art	S68	Switch, Fuel Diff Press
P1017	Plug, Ext. Fuel Disc. L/H	S59	Switch, Anti-Coll, Lt.
P1027	Plug, Ext. Fuel Disc. R/H	S82	Switch, Non-Ess Bus Cont
's 1	Pilot 5V Power Supply	S83	Switch, Ext. Fuel Jett
S2	Copilot 5V Power Supply	S68	Switch, Force Trim
E1131C	Power Module	S70	Switch, Starter-Gen.
R1	Shunt, Ammeter (Stby Gen)	S73	Switch, Overheat Bleed Air
R2	Shunt Ammeter @la.in Gen	S75	Switch, Searchlight (ON-STOW)
R3	Resistor, Windshield Wiper	S76	Switch Landing Lt. (ON-OFF)
R4	Rheostat, Pilot Inst. Lt. Dim	S78	Switch, Cargo Rel. (Copilot)
R5	Rheostat, Sec. Instrument Lt. Dim	S79	Switch, Fuel Ejector Flow Sw. L/H
R6	Rheostat, Overhead Console	S80	Switch, Fuel Ejector Flow Sw. R/H
R7	Resistor, Nav. Lts. Dim	S81	Switch, De-ice (ON-OFF)
R8	Rheostat Peal- Lts. Dim	983	Switch, Bleed Air (ON-OFF)
R9	Rheostat Eng Inst. Lts. Dim	S85	Switch, Aft Outlists (Htr)
R10	Rheostat Copilot Inst. Lts. Dim	S87	Switch, Aft-Outlet Limit
R11	Resistor Fire Det. Cont	S93	Switch, Hi-Lo RPM
R12	Resistor Speel Thermocouple	S94	Switch, Fuel Filter Bypass
R21	Rheostat Aft Dome Lts.	S111	Switch, Fuel Trans. Pump
I126	Rheostat Course Ind. Lt. Dim	S112	Switch, Pilot Hoist cont
R27	Resistor AC Load Balancing	S114	Switch, Fire Control
S1	Switch, Aft Demo Lt.	S116	Switch, Fire Control
S2	Switch Rotary (DC VM sel)	S124	Switch, Sel-Windshield Wiper
34	Switch XMSN Sump Insp. Lt.	S134	Switch, Chip Det. SeL
S5	Switch, Fuel Qty. Test	S195	Switch, Diff. Press.
S6	Switch Starter (Plt Coll.)		
S7	Switch Hyd. Boost Cont	T1	Transformer 116/28V
S8	switch Gen (on-off Reset	TB1	Term. Blk. Fwd. Inst. Panel
S9	Switch Pitot Heater	TB2	Term Blk Overhead Console R/H
910	Switch Force Trim (Copilot Cyc.)	TBS	Term. Blk Overhead console L/H
911	Switch, Rotary (AC VM sel)	TB4	Term. Blk Ant Fuel Cell
912	Switch Searchlight Cont	TB9	Term. Blk. Top Ext. & Demo Lts.
S13	Switch Nav. Lts. (Flash Steady)	TB12	Term. Blk. Ped. Panel Edge Lts.
S14	Switch Nav. Lts. (Bright-Dim)	TB13	Term. Blk Inst. Panel Lts.
918	Switch Force Trim (Pit-CyC)	TB14	Term. Blk. Inst. Panel Sec Lts.
920	Switch Test (Fire Det)	TB15	Term. BW Cockpit Lts. L/H
S23	Switch Wndshield Wiper	TB16	Term. Blk Cockpit Lts. R/H
S26	Switch Landing (It. (Ext-Rotr	TB25	Term. Blk Thermocouple Ind.
828	Swttch XMSN Oil Temp.	TB26	Term. Blk. DC Gnd. & Audio
S27	Switch Hyd. Press	TB27	Term. Blk. Aft Thermo Lead
S28	Switch XMSN Oil Press Warn.	TB29	Term. Blk. Inst. Gnd.
S29	Switch Eng. 011 Press Warn	TB34	Term. Blk. Aft Dome Lt. Panel
931	Switch, Limit Ext Pwr. Door)	TB35	Term. Blk. R/H Fuel Cell
S32	Switch, Cargo Release (Plt.)	TB36	Term. Blk. Ext. Pwr. Diode
S33	Switch, Gov. (Aut0-Emer)	TB38	Term. Blk. L/H Fuel Call
936	Switch, cargo Release	TB39	Term. Blk. Elect. Compt. Aft
S37	Switch, RPM Gov. (Pit)	TB45	Term. Blk. Pitot Htr. - Disc.
838	Switch Fuel (ON-OFF)	TB80	Term. Blk. Battery Voltage, Fwd.
939	Switch Invtr. (MiLin-spare)	TB61	Term. Blk. Battery Voltage, Aft
S40	Switch Battery (ON-OFF)	TB62	Term. Blk. Crew Pos 1
S41	Switch Upper Float	TB63	Term. Blk. Crew Pos 2
S42	Switch Lower Float	TB64	Term. Blk. Crew Pos 3
S44	Switch, Fuel-Low Level	TB100	Term. Blk. Pilot and Copilot 5V Power Supply
S45	Switch Fuel-Transfer L/H		
S46	Switch Fuel-Transfer R/H		
S50	Switch, Idle Stop Rel (Pit)		
S51	Switch RPM Gov (Copilot)		

Table F-4. Equipment List - Helicopters Serial No. 68-15214 and Subsequent (Cont)

ITEM NO.	DESCRIPTION	ITEM NO.	DESCRIPTION
VR1	Regulator - Voltage (Main Gen)		
VR2	Regulator - Voltage (Stby Gen)		
WI	Cable Assy. Fire Det.		
<b>Z2</b>	Eng. Ignition Unit		





Table F-5. Connector Replacement Chart

WIRE NO.	RECEPTACLE	PIN	PLUG	WIRE NO.
D9A20	J3	A	P3	D9B20
X11A20	J3	B	P3	X11B20
X12A20	J3	C	P3	X12B20
D13B22	J3	D	P3	D13A22
D12A22	J3	E	P3	D12B22
D35A20	J3	F	P3	D35B20
D34B20	J3	G	P3	D34C20
L36A20	J3	H	P3	L36B20
L20F20	J3	J	P3	L20E20
W109A20	J3	R	P3	W109B20
E32A20	J3	S	P3	E32B20
W2B20	J3	T	P3	W2A20
W4B20	J3	U	P3	W4C20
M3F20	J3	V	P3	M3G20
E7D18N	J3	w	P3	E7E18N
M1C20	J3	X	P3	M1D20
W12A20	J3	Y	P3	W12B20
W6A20	J3	Z	P3	W6B20
L20A20	J3	a	P3	L20B20
L19A20	J3	b	P3	L19B20
L18A20	J3	c	P3	L18B20
C12A20	J20	A	P20	P/O Equipment
M4B20	J20	c	P20	P/O Equipment
M3E20	J20	E	P20	P/O Equipment
	J20	G	P20	P/O Equipment
	J20	H	P20	P/O Equipment
M29A20	J20	L	P20	P/O Equipment
M27A20	J20	M	P20	P/O Equipment
M30A20	J20	N	P20	P/O Equipment
M22A20	J20	P	P20	P/O Equipment
M28A20	J20	R	P20	P/O Equipment
RZ1714B20	J20	S	P20	P/O Equipment
RZ1853B20N	J20	T	P20	P/O Equipment
RZ1715C20	J20	U	P20	P/O Equipment
C1C20	J20	V	P20	P/O Equipment
M43C20	J21	A	P21	M25A20
	J21	B	P21	
	J21	C	P21	
L21C20	J21	D	P21	L21B20
C8B20	J21	E	P21	C8A20
C9A20	J21	F	P21	C9B20
L22E20N	J21	G	P21	L22D20N
W18B20	J21	H	P21	W18A20
W17A20	J21	I	P21	W17B20
M44A20	J21	J	P21	M26A20
W19C20	J21	K	P21	W19B20
C12B20	J21	L	P21	C12A20
C21A20	J21	M	P21	C21B20
	J21	N	P21	
M4C20	J22	A	P22	P/O Equipment
	J22	B	P22	P/O Equipment
	J22	C	P22	P/O Equipment
	J22	D	P22	P/O Equipment
C21B20	J22	E	P22	P/O Equipment

Table F-5. Connector Replacement Chart (Cont)

WIRE NO.	RECEPTABLE	PIN	PLUG	WIRE NO.	
C13A20	J22	F	P22	P/O Equipment	
	J22	G	P22	P/O Equipment	
	J22	H	P22	P/O Equipment	
	M3C20	J22	J	P22	P/O Equipment
		J22	K	P22	P/O Equipment
RZ1752C20	J22	L	P22	P/O Equipment	
RZ1854B20N	J22	M	P22	P/O Equipment	
RZ1751B20	J22	N	P22	P/O Equipment	
	J22	U	P22	P/O Equipment	
L22A20N	J23	A	P23	L22B20N	
L21H20	J23	B	P23	L21G20	
Q52A20	J23	C	P23	Q52B20	
W102B20	J23	D	P23	W102A20	
W103B20	J23	E	P23	W103A20	
Q53D20	J23	F	P23	Q53C20	
J3H20	J23	H	P23	J3G20	
J4A20	J23	J	P23	J4B20	
Q12D20	J23	K	P23	Q12E20	
	J23	L	P23		
	J23	M	P23		
	J23	N	P23		
	J23	P	P23		
	J23	R	P23		
	J23	S	P23		
	J23	T	P23		
	J23	U	P23		
	J23	V	P23		
	J23	w	P23		
	J23	X	P23		
	J23	Y	P23		
J23	Z	P23			
J23	a	P23	Q11B20		
J23	b	P23	Q10A20		
J23	c	P23	Q12B20		
J23	d	P23	E37C20		
J23	e	P23	E46B20		
J23	f	P23	E46B20		
J23	g	P23	Q30B20		
J23	h	P23	Q29A20		
J23	i	P23	Q50B20		
J23	j	P23	E44B20		
J23	k	P23	Q51B20		
J23	m	P23	J2B20		
J23	n	P23	J1A20		
J23	P	P23	Q4B20		
J23	q	P23	Q3A20		
J23	r	P23	H61B16		
J23			Q5B20		
J23			Q1A20		
J23			Q2B20		
J23			H60B16		
J2D20 J2B20	J25	A	P25	J2E20	
L43B20	J25	B	P25	L43A20	
L42A20	J25	C	P25	L42B20	
L30C20	J25	D	P25	L30B20	
J3B20	J25	E	P25	J3A20	
K2A20	J25	F	P25	K2B20	
L34B20	J25	G	P25	L34A20	
Q25B20	J25	H	P25	Q25A20	

Table F-5. Connector Replacement Chart (Cont)




WIRE NO.	RECEPTABLE	PIN	PLUG	WIRE NO.
L51B20	J25	J	P25	L51A20
L20T20	J25	K	P25	L20U20
	J25	L	P25	
	J25	M	P25	
	J25	N	P25	
	J25	P	P25	
	J25	R	P25	
J3G20 	P25	s	P25	J3F20
Q24A20	J25	T	P25	Q24B20
L53A20N	J25	U	P25	L53B20
Q26B20	J25	V	P25	Q26A20
Q22B20	J25	W	P25	Q22A20
Q23B20	J25	X	P25	Q23A20
L33B20	J25	Y	P25	L33A20
K3B20	J25	Z	P25	K3A20
L44B20	J25	a	P25	L44A20
L31B20	J25	b	P25	L31A20
L38B20	J25	c	P25	P38A20
D16B20	J41	A	P41	D16A20
D17A20	J41	B	P41	D17B20
	J41	C	P41	
	J41	D	P41	
	J41	E	P41	
	J41	F	P41	
	J41	G	P41	
	J41	H	P41	
	J41	J	P41	
W19B20	J41	L	P41	W19A20
	J41	M	P41	
D5A20	J41	N	P41	D5B20
D6B20	J41	P	P41	D6 C20
D1B20	J41	R	P41	D1A20
D22A20	J41	S	P41	D22B20
D2B20	J41	T		
		U	P41	D25B20N
D23A20	J41	V	P41	D23B20
P/O Equipment	J91	B	P91	
P/O Equipment	J91	C	P91	Q28A16
P/O Equipment	J91	D	P91	H61C16
P/O Equipment	J91	E	P91	E1A18
P/O Equipment	J91	F	P91	E2A18
P/O Equipment	J91	G	P91	E21A18
P/O Equipment	J91	H	P91	E22A18
P/O Equipment	J91	J	P91	J3E18
P/O Equipment	J91	K	P91	J4C18
P/O Equipment	J91	L	P91	Q12C18
P/O Equipment	J91	M	P91	Q11C18
P/O Equipment	J91	N	P91	E8A18
P/O Equipment	J91	P	P91	E9B18
P/O Equipment	J91	R	P91	
P/O Equipment	J91	U	P91	
P/O Equipment	J91	V	P91	
P/O Equipment	J91	D	J91	
H56A20 	J92	A	P92	 H56A20
Q46B20	J92	B	P92	Q46C18

Table F-5. Connector Replacement Chart (Cont)



















WIRE NO.	RECEPTACLE	PIN	PLUG	WIRE NO.
P35A16	J92	C	P92	P35B16
Q45B20	J92	D	P92	Q45C18
Q47A20N	J92	E	P92	Q17B18
W16B20	J92	F	P92	W16A18
Q15A20	J92	G	P92	Q15B18
H61B16	J92	H	P92	H61C16
Q67B20N	J92	J	P92	Q67A18
Q66A20	J92	K	P92	Q66B18
E11B20	J92	L	P92	E1A18
E2B20	J92	M	P92	E2A18
E21B20	J92	N	P92	E21A18
E22B20	J92	P	P92	E22A18
J 3D20	J92	R	P92	J3E18
J 4B20	J92	s	P92	J4C18
Q12B20	J92	T	P92	Q12C18
Q28B16N	J92	U	P92	Q28A16
Q1 1B20	J92	V	P92	Q11C18
E 8A20	J92	W	P92	E8A18
E 9A20	J92	X	P92	E9B18
E29B20N	J92	Z	P92	E29A18
Q17A20	J92	a	P92	Q17B18
E1 15A20	P92	b	P92	E15B18
H55A20 	P92	c	P92	H55B18
H54A20 	P92	d	P92	H54B18
E5 B20	J92	e	P92	E5A18
E33C-CHROM	J92	f	P92	E33B-CHROM
Q1 8A20N	J92	g	P92	Q18B18
E14A20	J92	h	P92	E14B18
E3 1B20N	J92	i	P92	E31A18
E6A20	J92	k	P92	E6B18
E4 3C-ALML	J92	m	P92	E34B-ALML
Q3 1A18N	J92	n	P92	Q31B18
H57A20N	J92	P	P92	H57B18
H44A20 H52B20 	J92	r	P92	 H52C18 H44B18
H45A20 H53A20 	J92	s	P92	 H53B18 H45B18
Q46B20	J107	A	P107	Q46A20
Q45B20	J107	B	P107	Q45A20
Q24D20	J107	C	P107	Q24E20
Q22B20	J107	D	P107	Q22C20
K2C20 	J107	E	P107	 K2D20
J 2D20 	J107	F	P107	 J2C20
J 2B20	J107		P107	
Q23B20	J107	G	P107	Q23C20
J 3B20 	J107	I	P107	 J3C20
J 3D20	J107		P107	
K3 B20	J107	J	P107	 K3C20
K3 D20	J107		P107	
NOTES				
 EFF When Rescue Hoist Provisions preinstalled.  EFF 65-9565 thru 66-16033  EFF 68-15214 thru 70-15932  EFF 65-9565 thru 66-16867  EFF 65-9565 thru 67-19537				

Table F-5. Connector Replacement Chart (Cont)

WIRE NO.	RECEPTACLE	PIN	PLUG	WIRE NO.
P35A16	J92	C	P92	P35B16
Q45B20	J92	D	P92	Q45C18
Q47A20N	J92	E	P92	Q17B18
W16B20	J92	F	P92	W16A18
Q15A20	J92	G	P92	Q15B18
H61B16	J92	H	P92	H61C16
Q67B20N	J92	J	P92	Q67A18
Q66A20	J92	K	P92	Q66B18
E11B20	J92	L	P92	E1A18
E2B20	J92	M	P92	E2A18
E21B20	J92	N	P92	E21A18
E22B20	J92	P	P92	E22A18
J 3D20	J92	R	P92	J3E18
J 4B20	J92	s	P92	J4C18
Q12B20	J92	T	P92	Q12C18
Q28B16N	J92	U	P92	Q28A16
Q1 1B20	J92	V	P92	Q11C18
E 8A20	J92	W	P92	E8A18
E 9A20	J92	X	P92	E9B18
E29B20N	J92	Z	P92	E29A18
Q17A20	J92	a	P92	Q17B18
E1 15A20	P92	b	P92	E15B18
H55A20	P92	c	P92	H55B18
H54A20	P92	d	P92	H54B18
E5 B20	J92	e	P92	E5A18
E33C-CHROM	J92	f	P92	E33B-CHROM
Q1 8A20N	J92	g	P92	Q18B18
E14A20	J92	h	P92	E14B18
E3 1B20N	J92	i	P92	E31A18
E6A20	J92	k	P92	E6B18
E4 3C-ALML	J92	m	P92	E34B-ALML
Q3 1A18N	J92	n	P92	Q31B18
H57A20N	J92	p	P92	H57B18
H44A20 H52B20	J92	r	P92	H52C18 H44B18
H45A20 H53A20	J92	s	P92	H53B18 H45B18
Q46B20	J107	A	P107	Q46A20
Q45B20	J107	B	P107	Q45A20
Q24D20	J107	C	PI07	Q24E20
Q22B20	J107	D	P107	Q22C20
K2C20	J107	E	P107	K2D20
J 2D20	J107	F	P107	J2C20
J 2B20	J107		P107	
Q23B20	J107	G	PI07	Q23C20
J 3B20	J107	I	P107	J3C20
J 3D20	J107		P107	
K3 B20	J107	J	P107	K3C20
K3 D20	J107		P107	

NOTES

EFF When Rescue Hoist Provisions preinstalled.  
 EFF 65-9565 thru 66-16033  
 EFF 68-15214 thru 70-15932  
 EFF 65-9565 thru 66-16867  
 EFF 65-9565 thru 67-19537



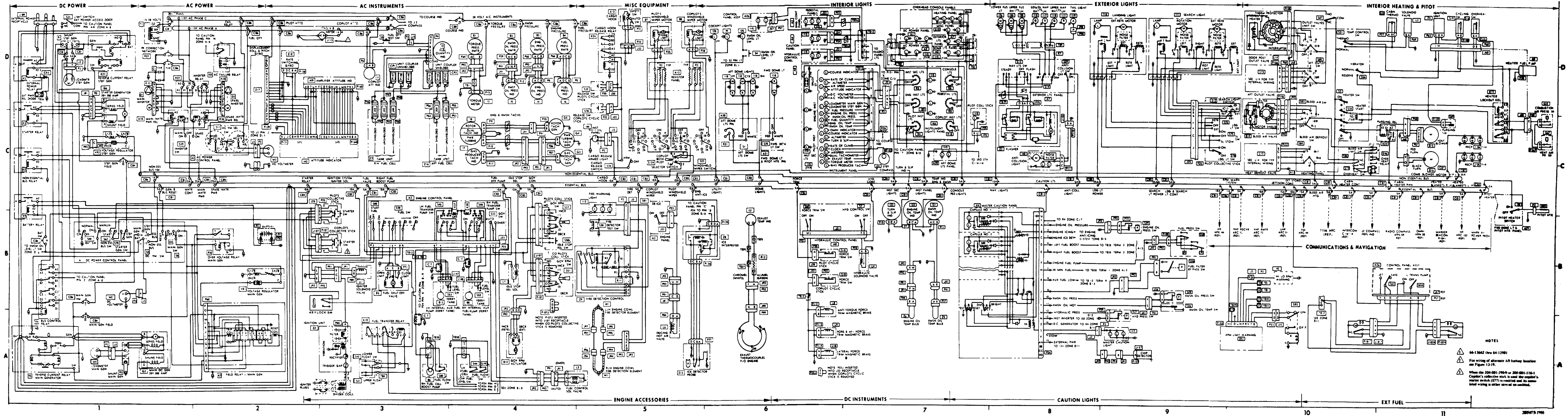


Figure F-3. Electrical Schematic—UH-1H (64-13492 through 64-13901)



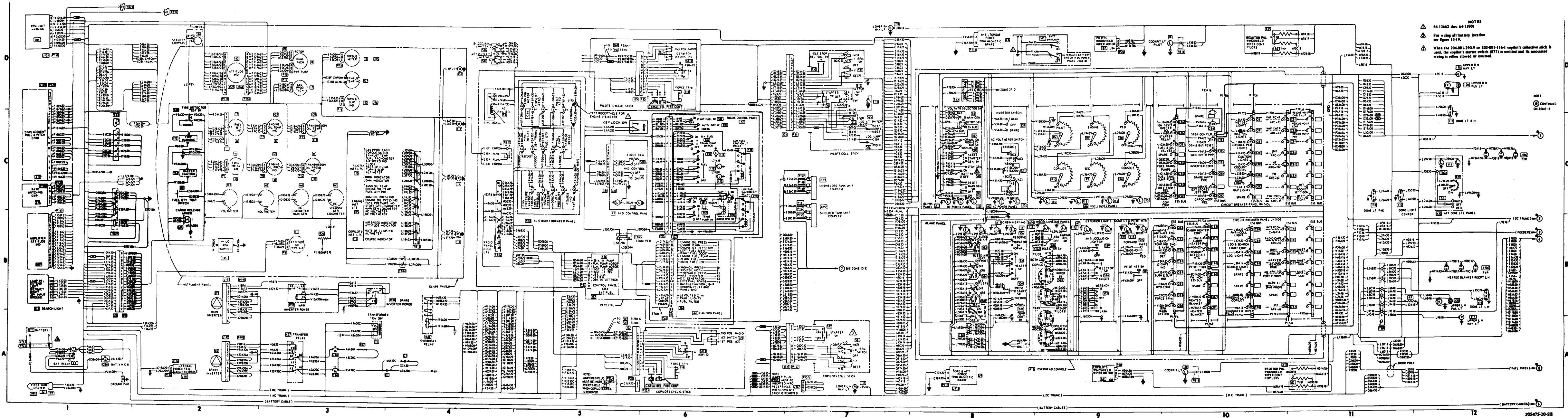


Figure F-4. Electrical wiring diagram—UH-1H (64-13492 through 64-13901) (Sheet 1 of 2)

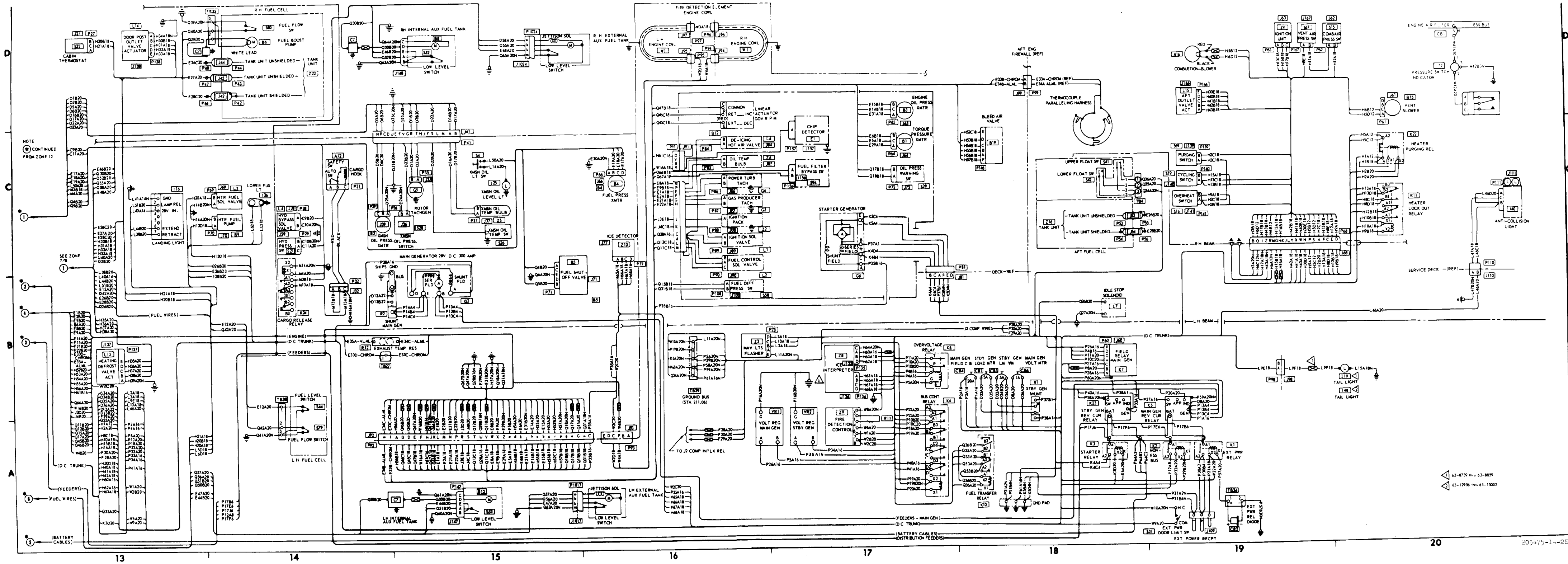
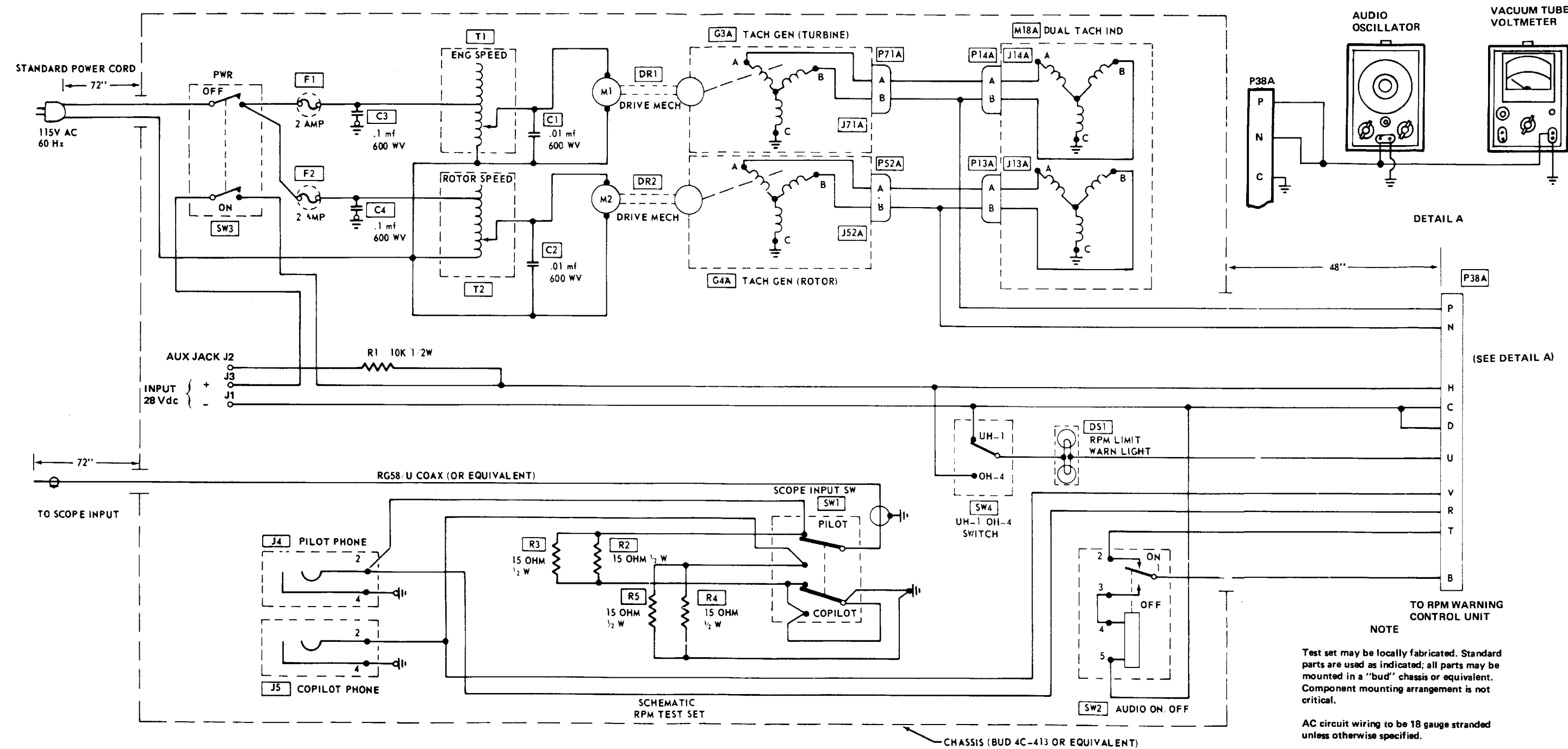


Figure F-4. Electrical wiring diagram—UH-1H (64-13492 through 64-13901) (Sheet 2 of 2)



FREQ HZ	VRMS	ENG RPM	ROTOR RPM
66.5	19.5	6200	306
69.0	20.0	6400	315
73.5	22.0	6800	334
76.0	22.5	7000	-

ID CODE	NOMENCLATURE	PART NO.
C1, C2 C3, C4 DR1, DR2	Line Filter .01 mf. 600 WV Line Filter .1 mf. 600 WV Rubber Flex Tube	(Non Polarized) (Non Polarized) Rubber Hose 1/4" I.D. (Bell 205-074-026-1)
DS1	Korry Light (033-0861-001)	(Bell 205-074-026-1)
F1, F2	Fuse Holder	HKF
G3A, G4A	Tach Generator (MIL-G26611)	Type GEU-7/A
J1, J2, J3 J4, J5	Banana Jack Phone Jack	Type GEU-7/A Standard 092 A/U
M1, M2	Tach Gen Drive Motor - Dayton Mod 2M037 - Ball Bearing 1/4" Shaft, 1/10 HP, 8000 RPM, 115Vac, 60 Hz	
M18A	Dual Tach Indicator - GE 8DJ67FBC Sub 1	(Bell 204-070-055-1)
P13A	Plug, Dual Tach Indicator	MS3106R14S-7S
P14A	Plug, Dual Tach Indicator	MS3106R14S-7S
P38A	Plug, Eng RPM Warning Control	MS3126F14-19S
P52A	Plug, Tach Generator	MS3108R12S-3S
P71A	Plug, Tach Generator	MS3108R12S-3S
R1	Resistor, 10K OHM 1/2W Carbon	(Tol. 5%)
R2, R3 R4, R5	Resistor, 15 OHM 1/2W Carbon	(Tol. 5%)
SW1	Switch, Scope Input	MS24659-23G
SW2	Switch, Audio On/Off (Micro)	5 ET1-S
SW3	Switch, Power On/Off	MS35059-22
T1, T2	Speed Control - Power Stat, Superior Electric Co. (0-140Vac, 60 Hz)	Type 10B

NOTE

Test set may be locally fabricated. Standard parts are used as indicated; all parts may be mounted in a "bud" chassis or equivalent. Component mounting arrangement is not critical.

AC circuit wiring to be 18 gauge stranded unless otherwise specified.

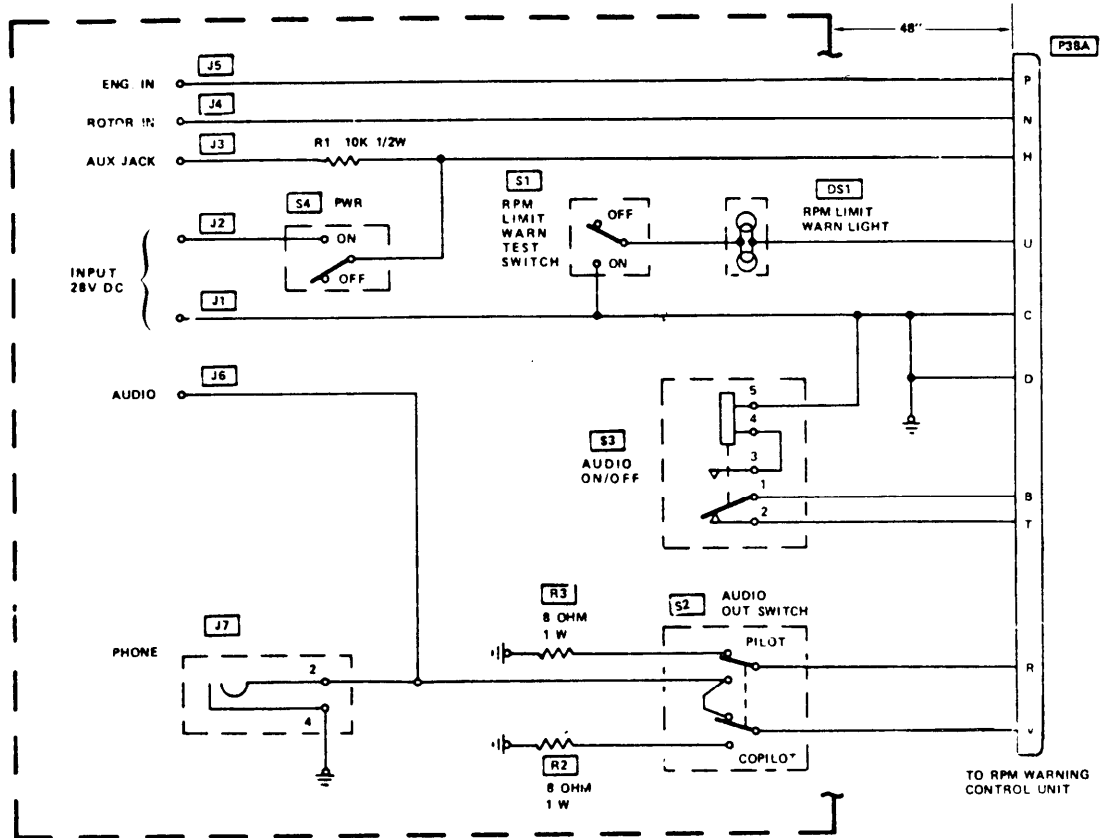
DC circuit wiring to be 22 gauge stranded unless otherwise specified.

205074-1004

Figure F-5. Rpm limit warning test set schematic

F-37/(F-38 blank)





ID CODE	NOMENCLATURE	PART NO.
DS1	LIGHT, RPM LIMIT WARN	205-074-026-1
J1, J2, J3 J4, J5, J6	JACK, BANANA	STANDARD
J7	JACK, PHONE	092 A/U
P38A	CONNECTOR, ENGINE RPM LIMIT WARNING	MS3126F 14 19S
R1	RESISTOR, 10K OHMS, 1/2 W	(5% TOL.)
R2, R3	RESISTOR, 8 OHMS, 1 W	(5% TOL.)
S1	SWITCH, RPM LIMIT WARN TEST	MS27787 30
S2	SWITCH, AUDIO OUT	MS24659 23G
S3	SWITCH, AUDIO ON OFF	5 ET1 S (MICRO SWITCH <sup>1</sup> )
S4	SWITCH, PWR	MS24659 23G
-	CHASSIS	

NOTES

- TEST SET MAY BE LOCALLY FABRICATED. STANDARD PARTS ARE USED AS INDICATED. ALL PARTS MAY BE MOUNTED IN A STANDARD CHASSIS OR EQUIVALENT.
- COMPONENT MOUNTING ARRANGEMENT IS NOT CRITICAL.
- ALL WIRING TO BE 22 GAUGE STANDARD UNLESS OTHERWISE SPECIFIED.

205074 2001

Figure F-6. Rpm limit warning test set schematic—BHT Model 205-074-033-103

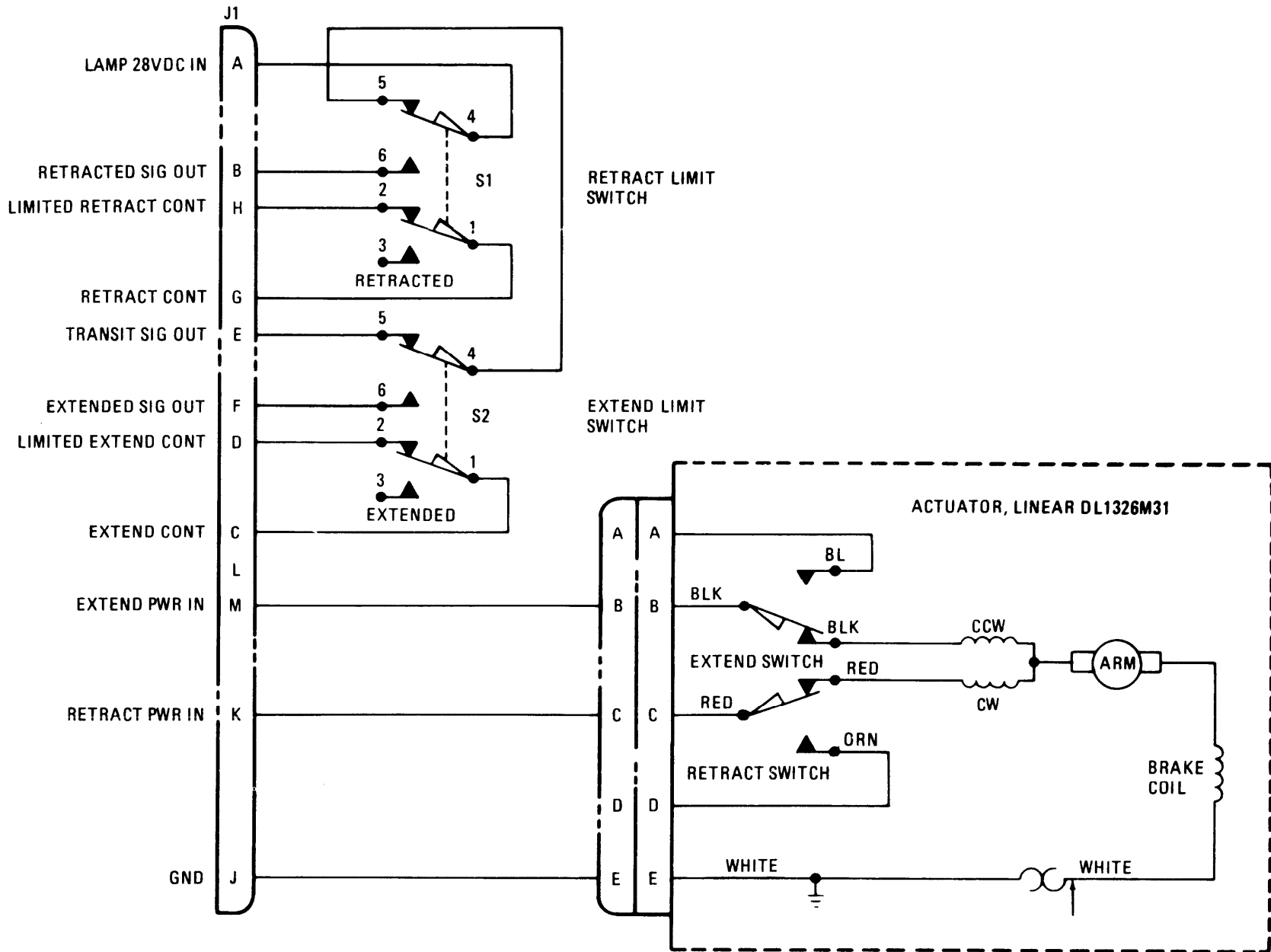


Figure F-7. Mission Antennas OE-201/AARQ-33 and OE-202/ARQ-33 Schematic Diagram

E H - 1 H

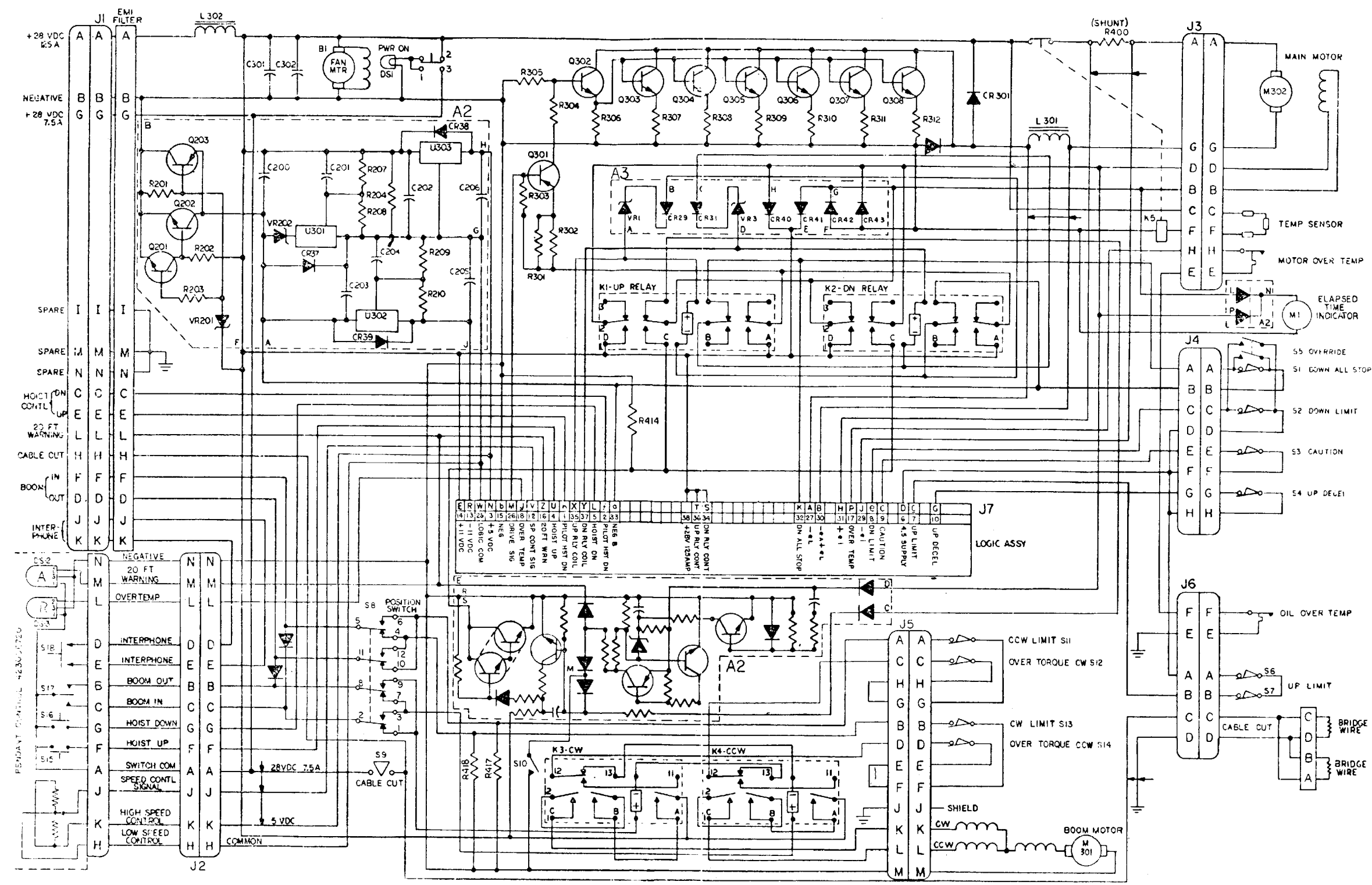


Figure F-8. High Performance Hoist System

F-41/(F-42 blank)





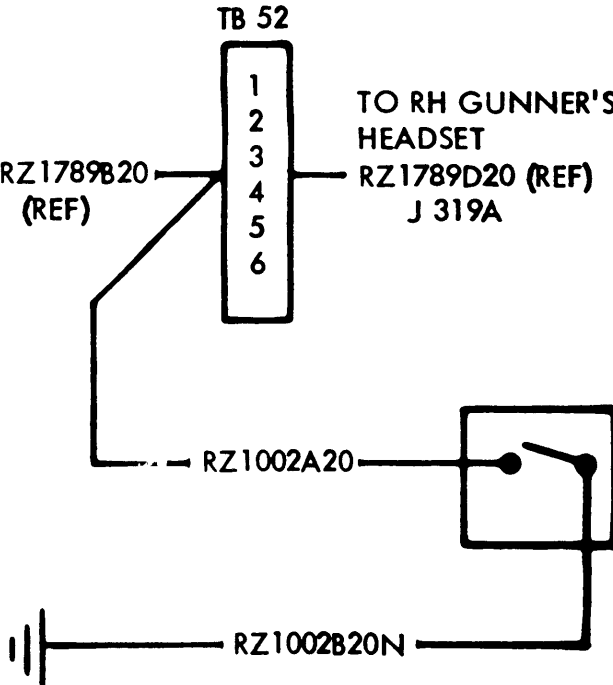
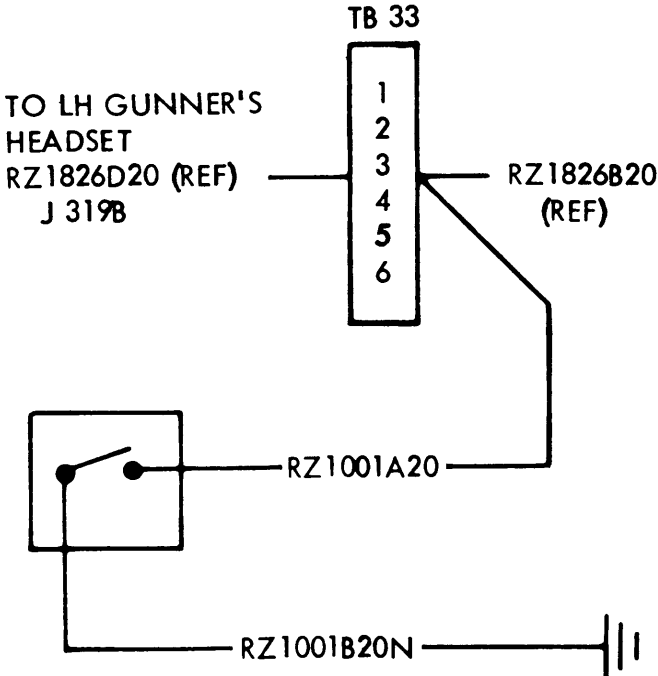


Figure F-9. Door gunner's foot mike switch

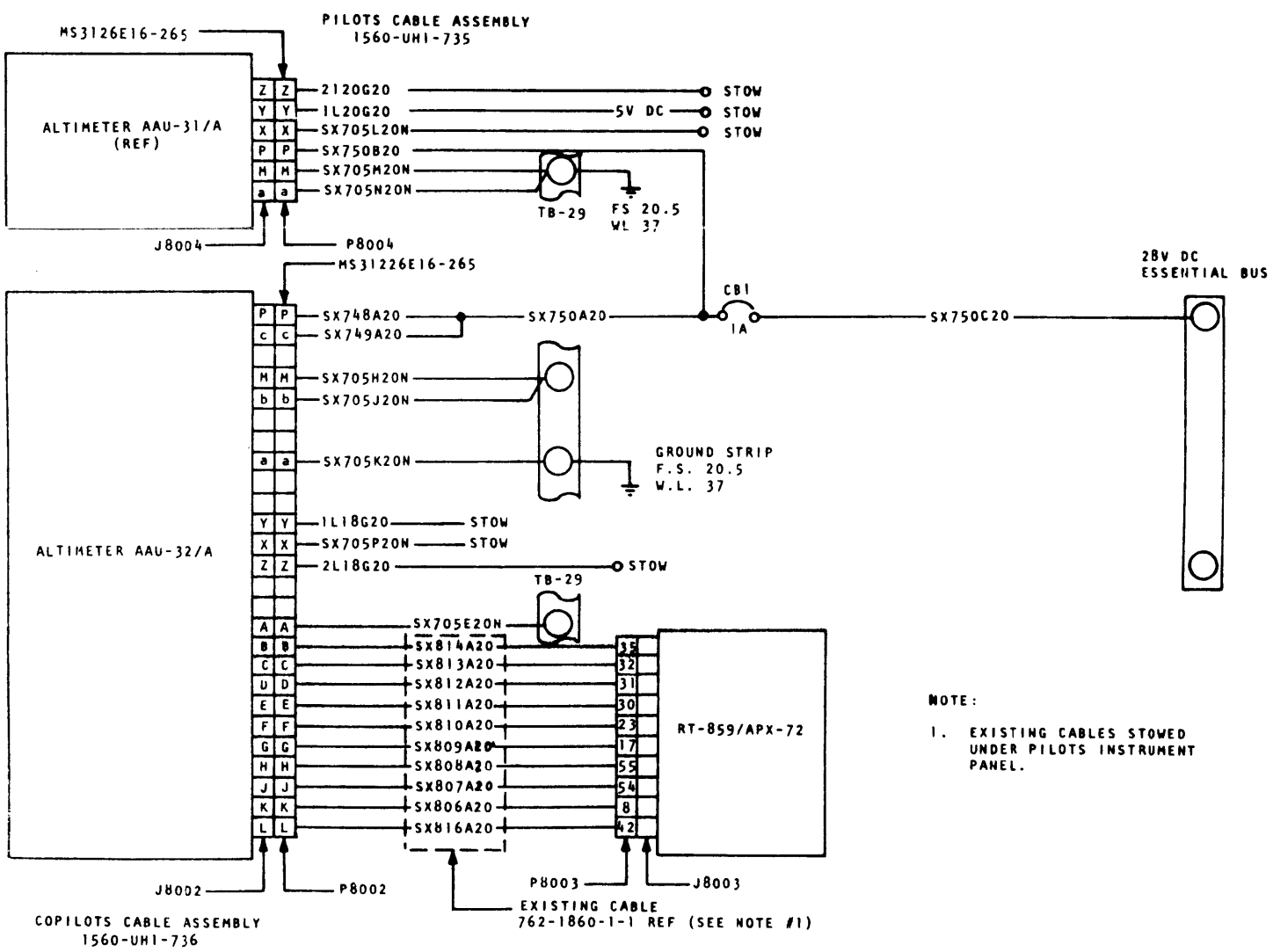
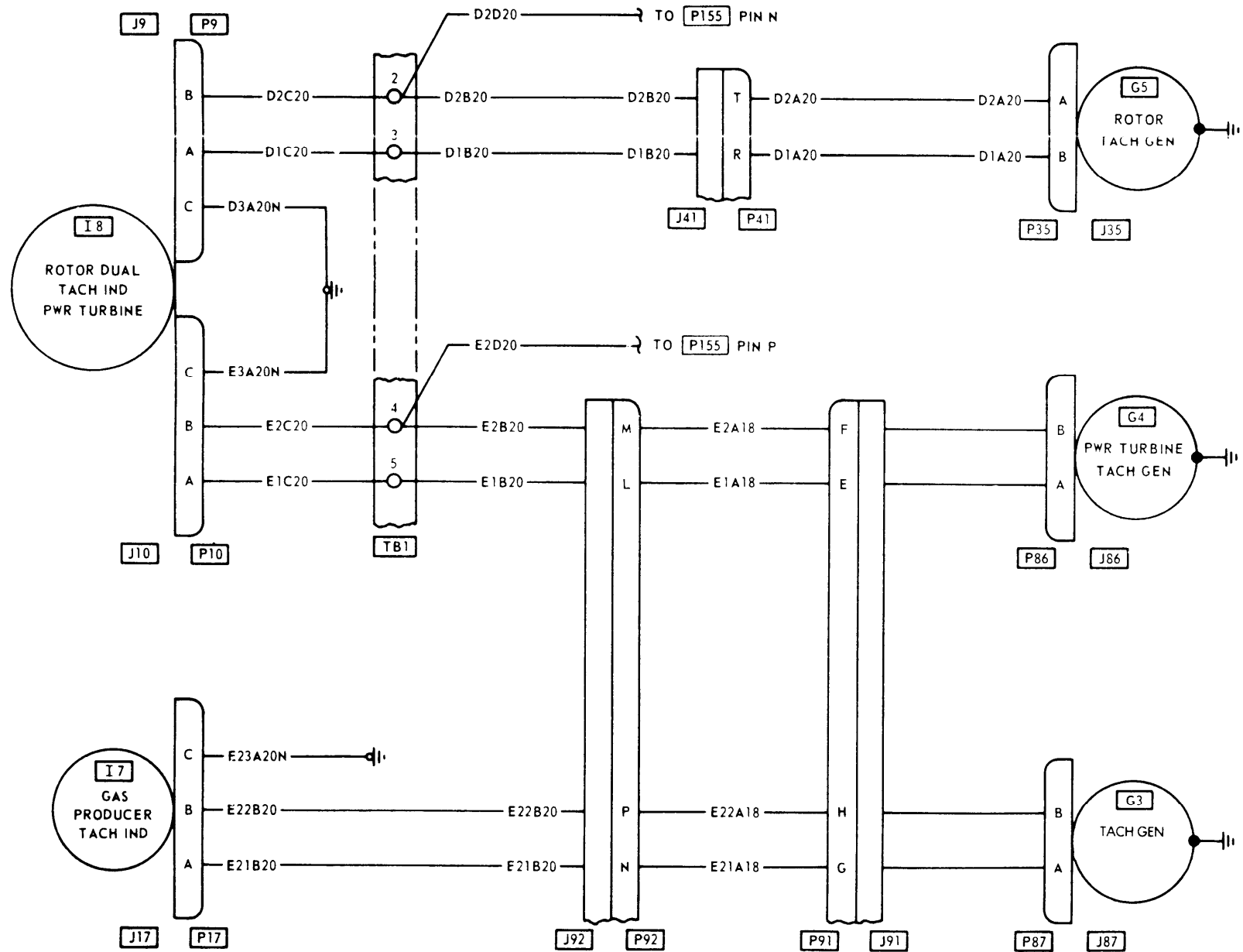
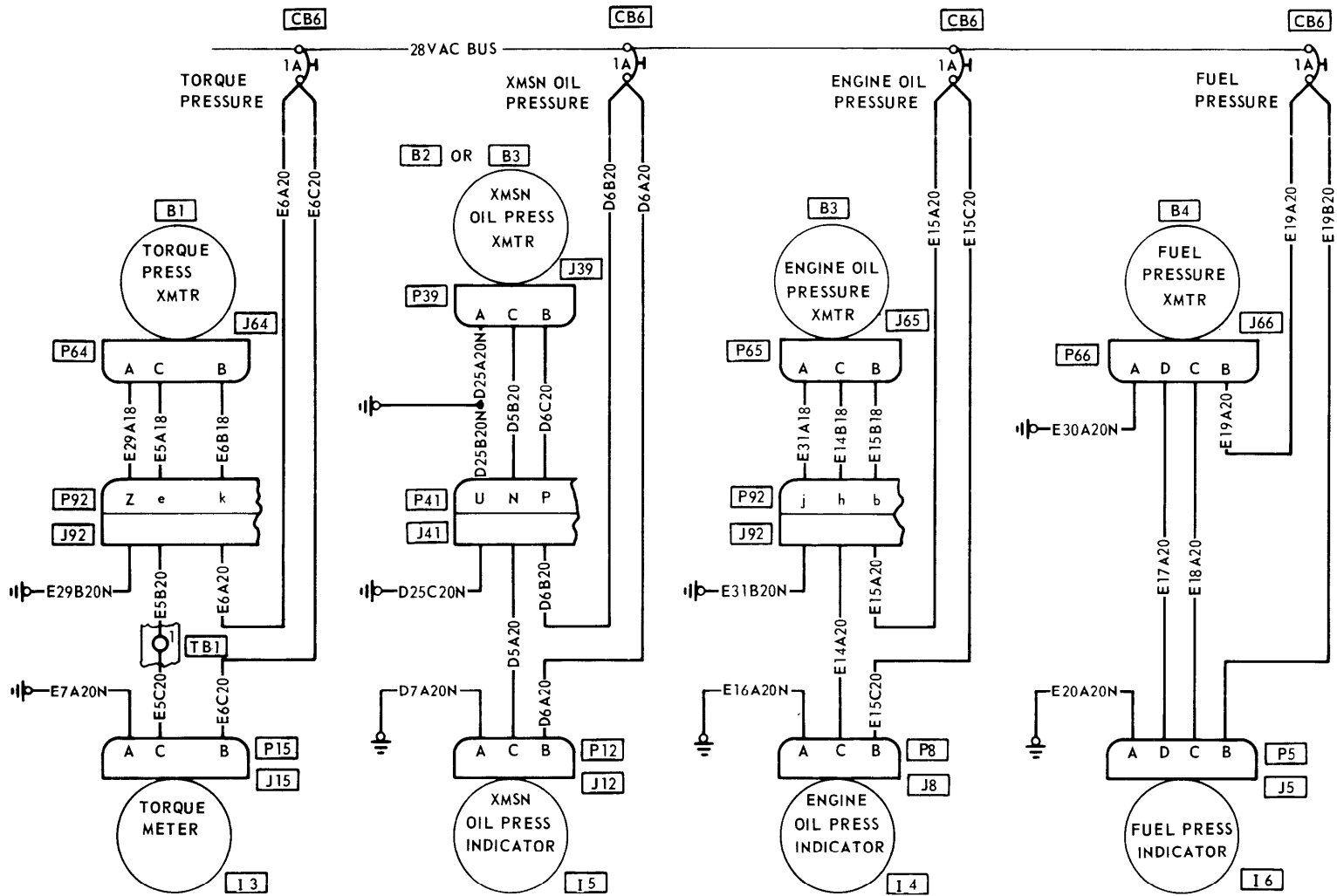


Figure F-10. Altimeter AAU-31/A and AAU-32/A and Transponder AN/APX-72 interconnecting wiring diagram



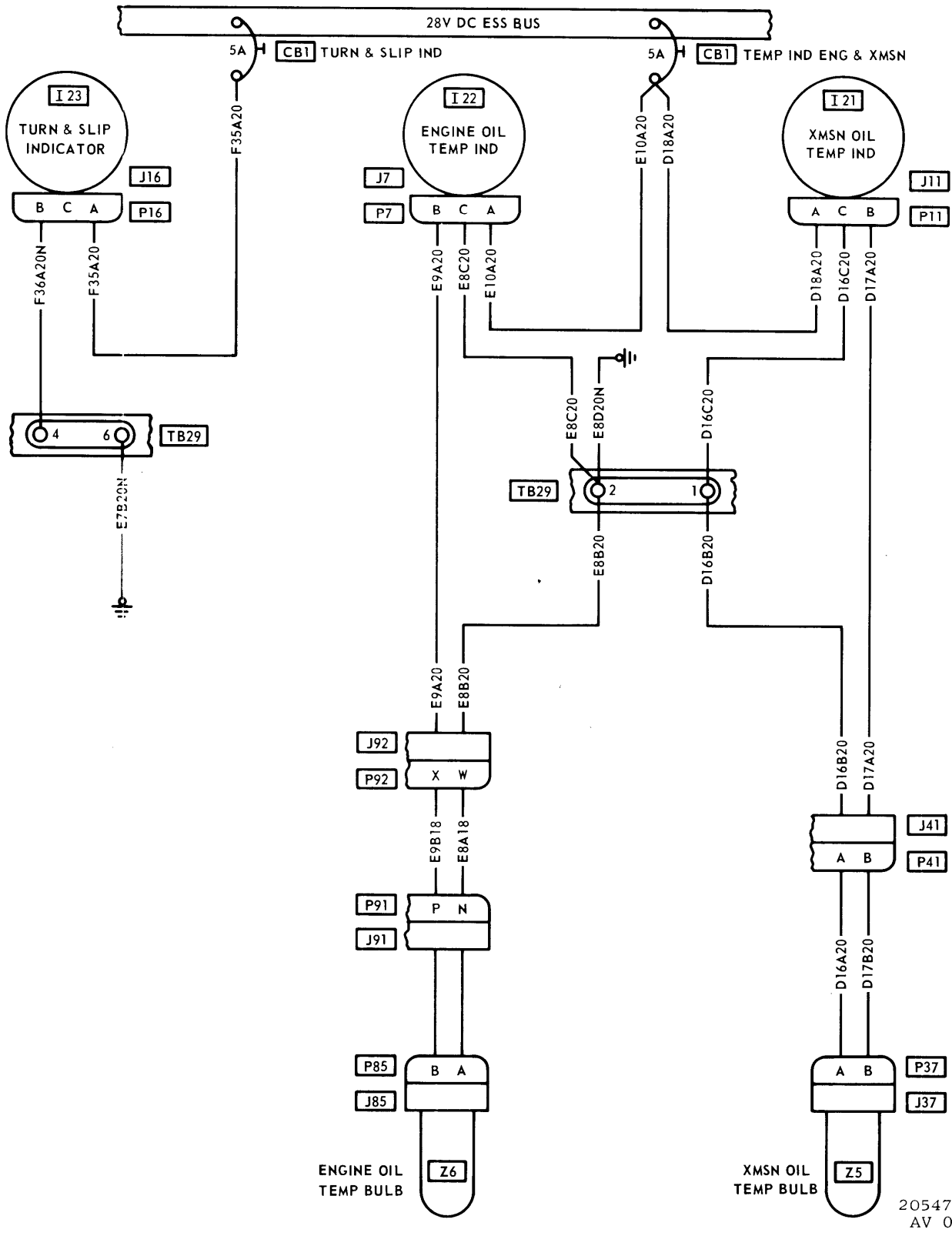
205475-135

Figure f-11. Tachometer generator system



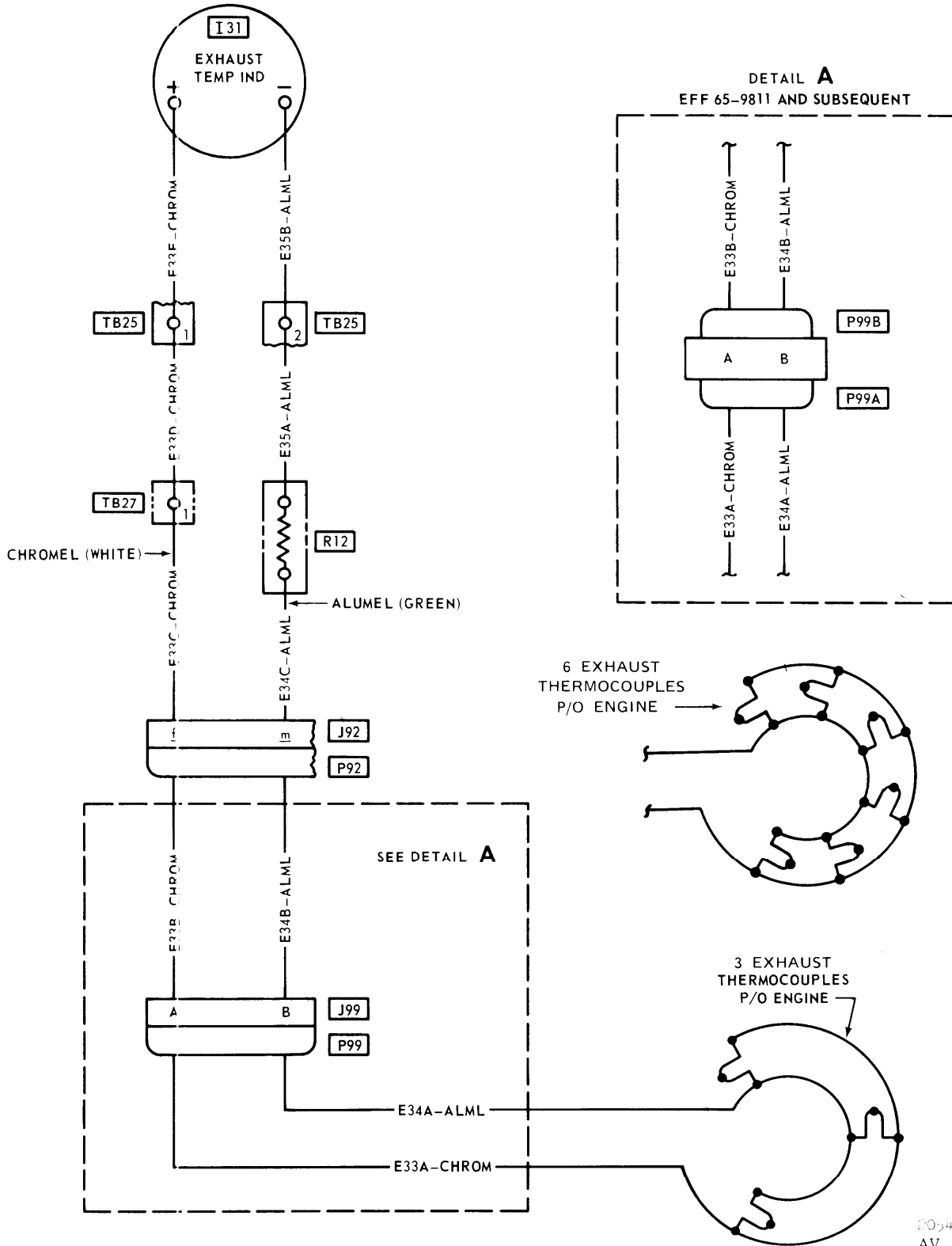
205475-114  
AV 054249

Figure F-12. AC pressure indicator system



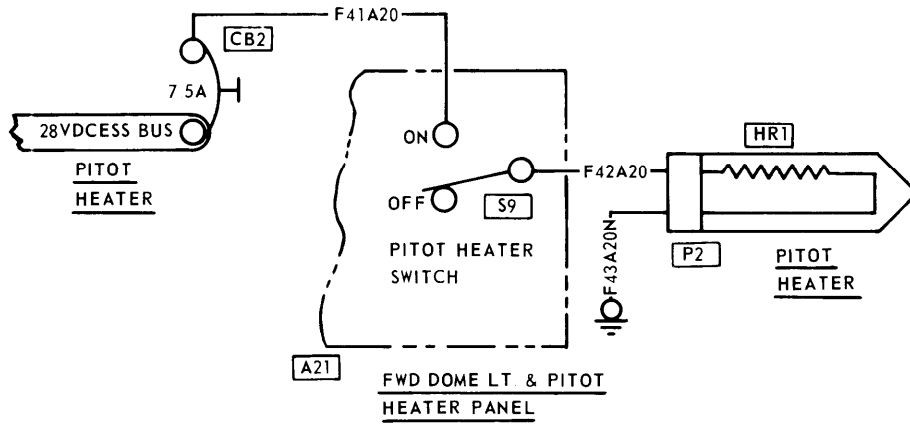
205475-130  
AV 054246

Figure F-13. Temperature bulb, turn and slip indicator system

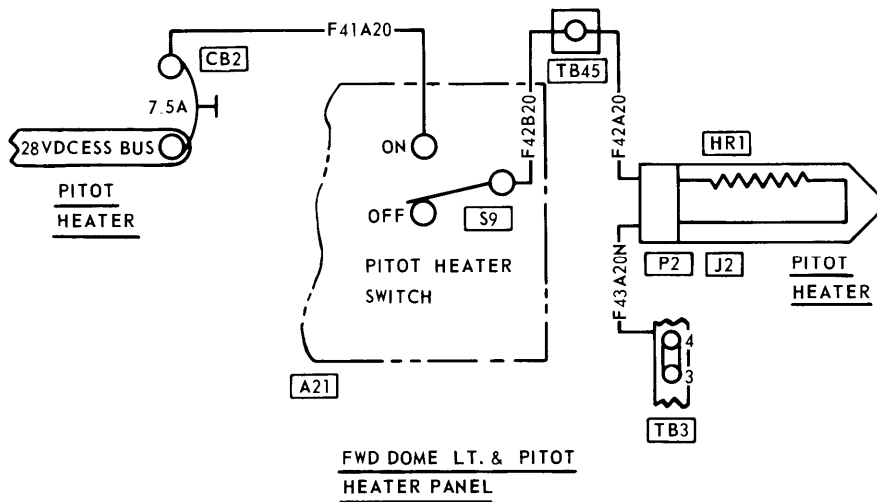


005475-1183  
AV 054250

Figure F-14. Exhaust temperature indicator system



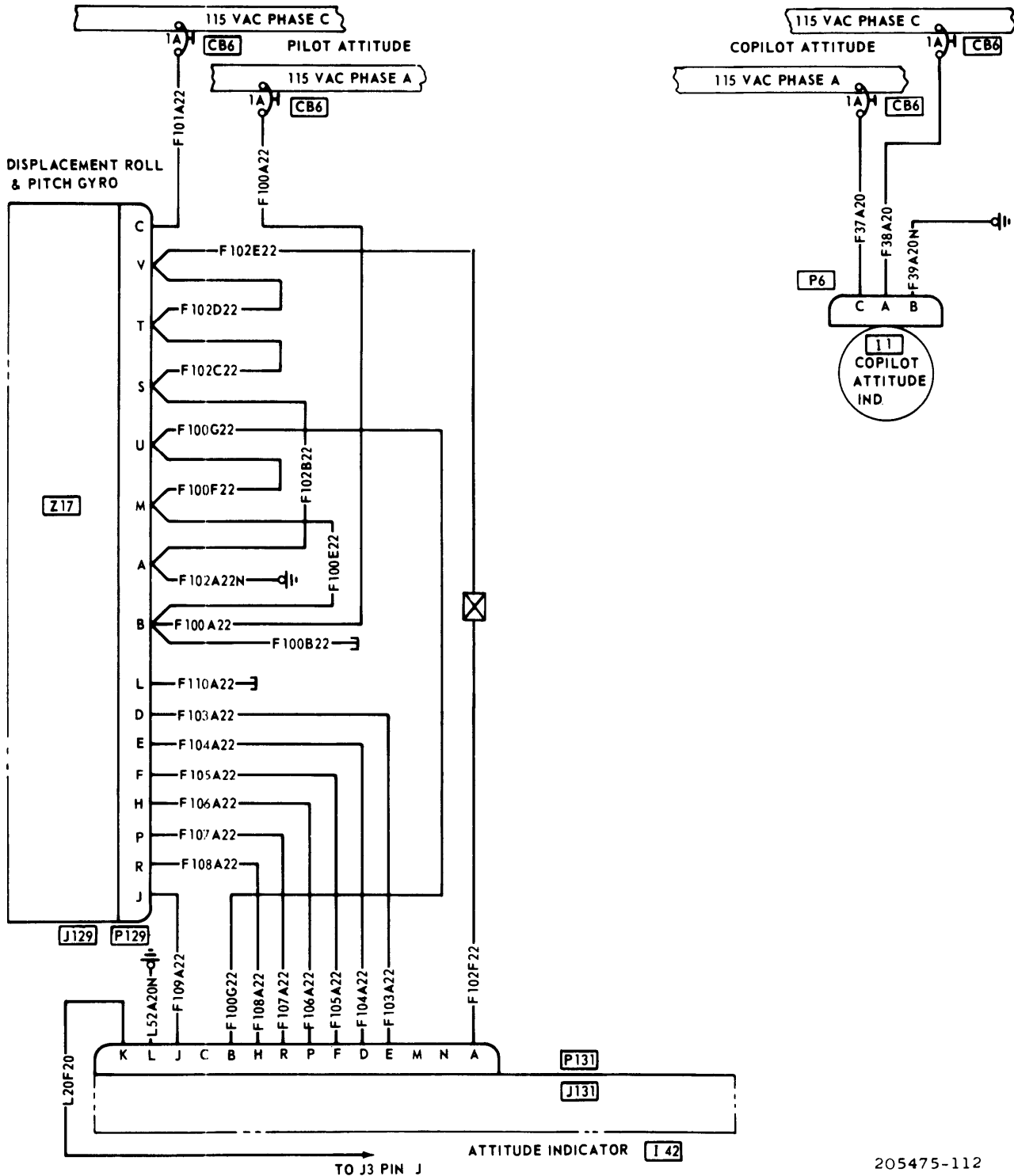
EFF 65-9565 THRU 65-12895



EFF 66-746 AND SUBSEQUENT

205475-116A  
AV 0564245

Figure F-15. Pitot heater system



205475-112

Figure F-16. Attitude indicator system



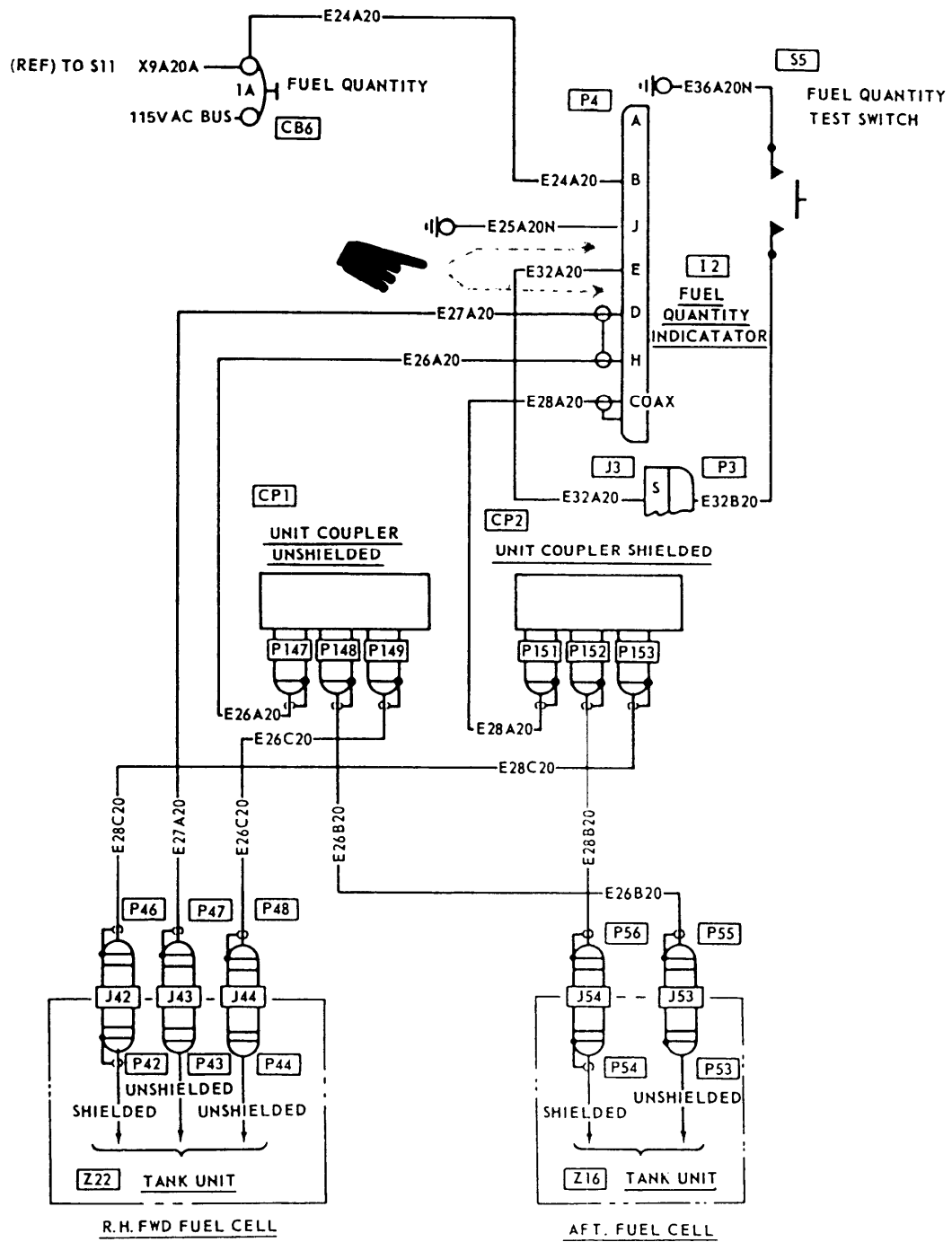
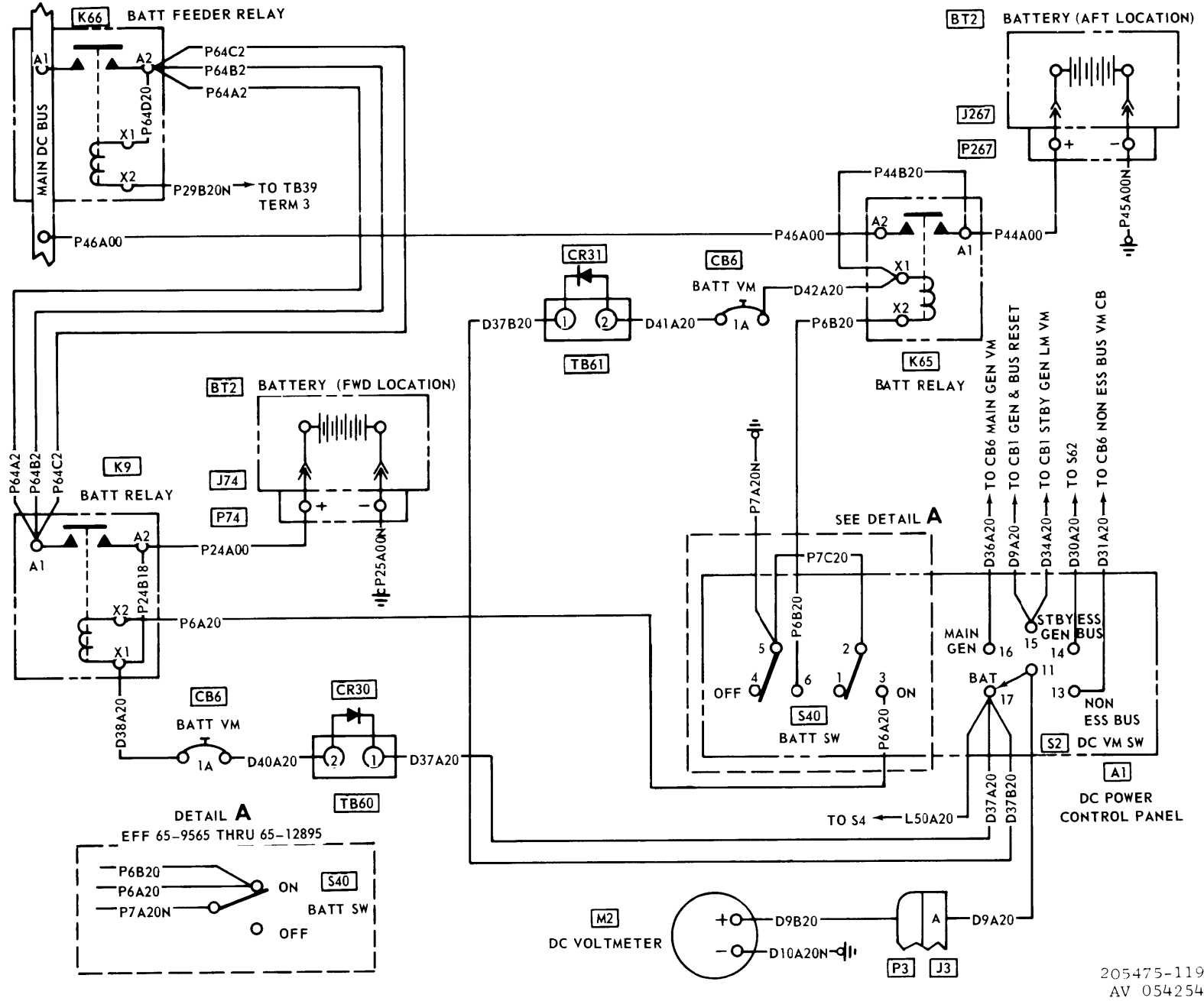


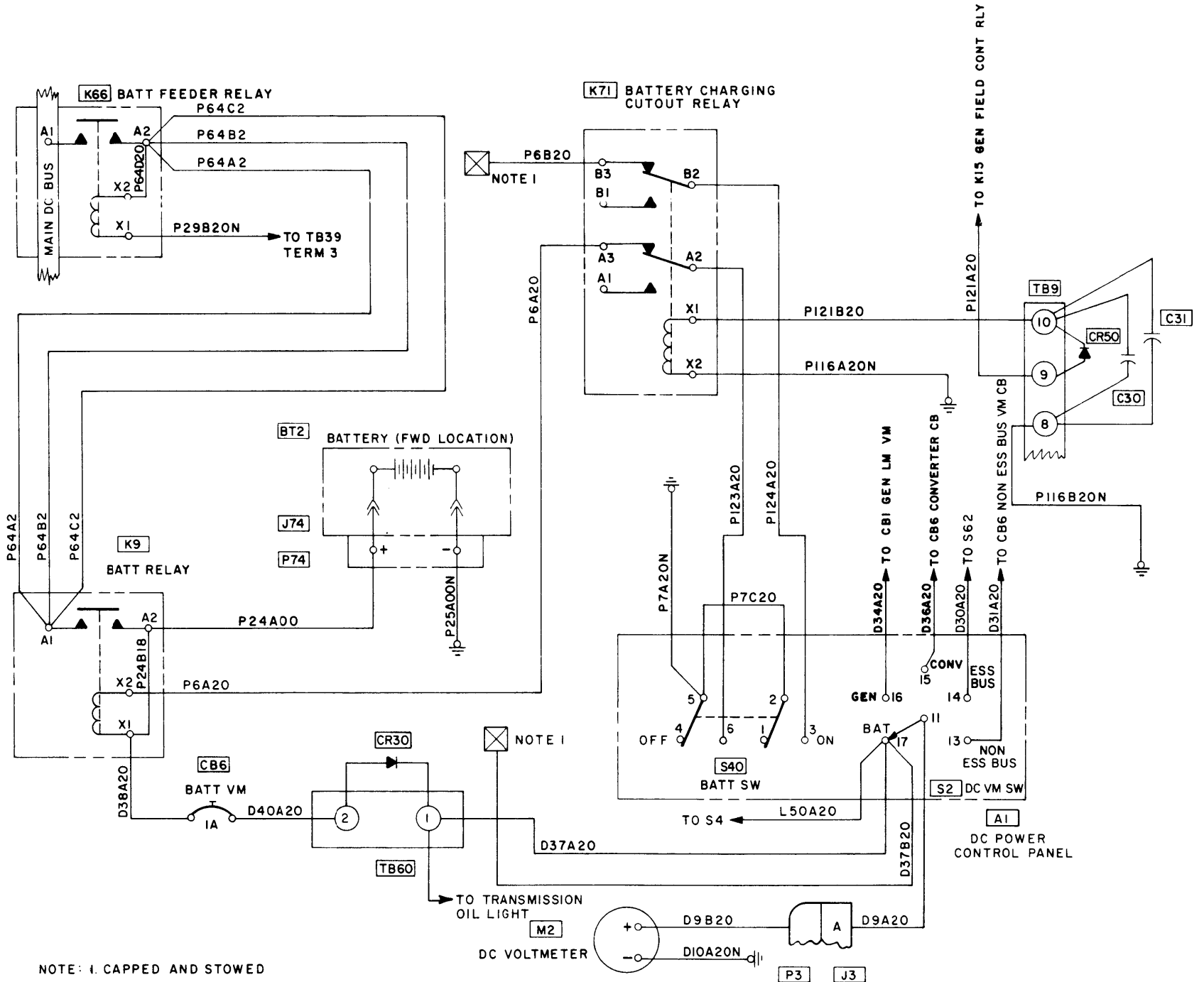
Figure F-17. Fuel Quantity System

Figure F-18. Battery system



205475-119  
AV 054254

Figure F-18.1. Battery system



NOTE: 1. CAPPED AND STOWED



Figure F-18.1 Battery system



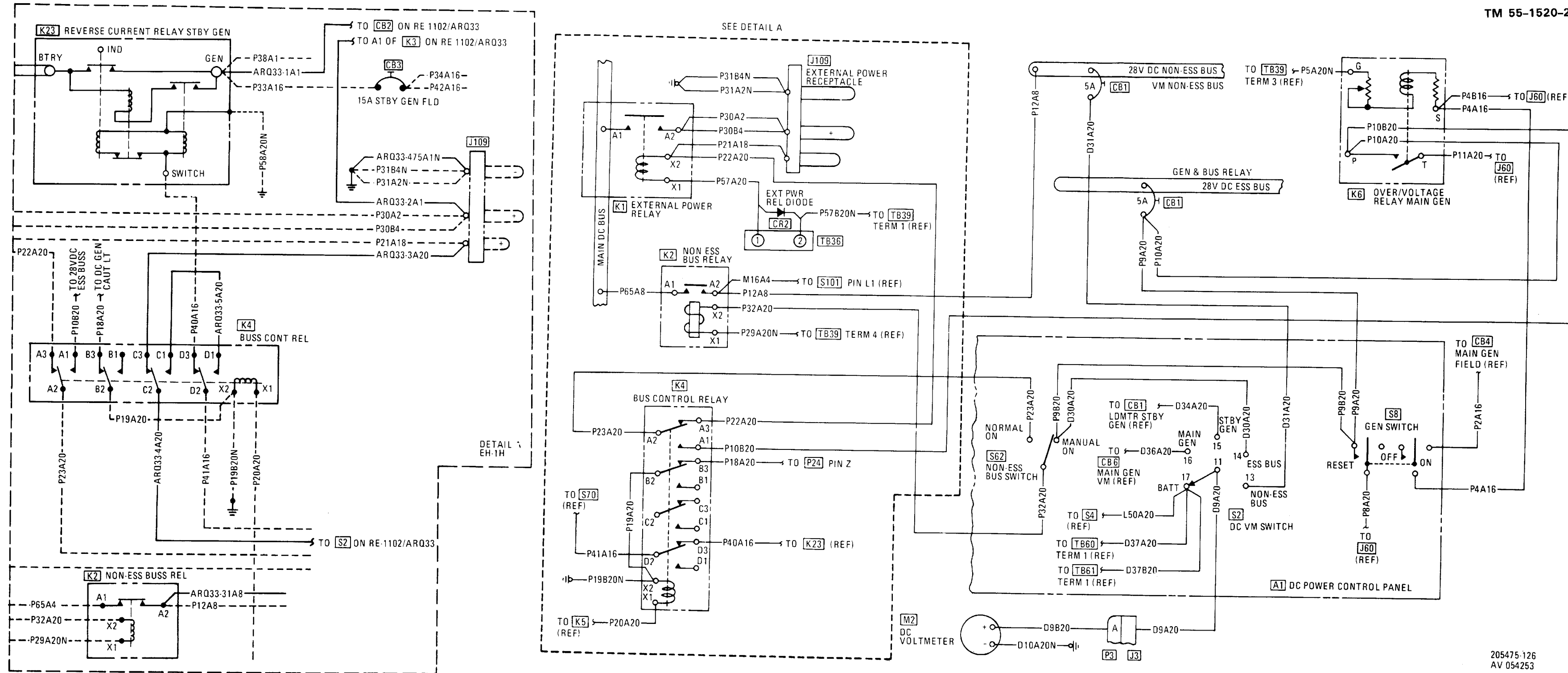
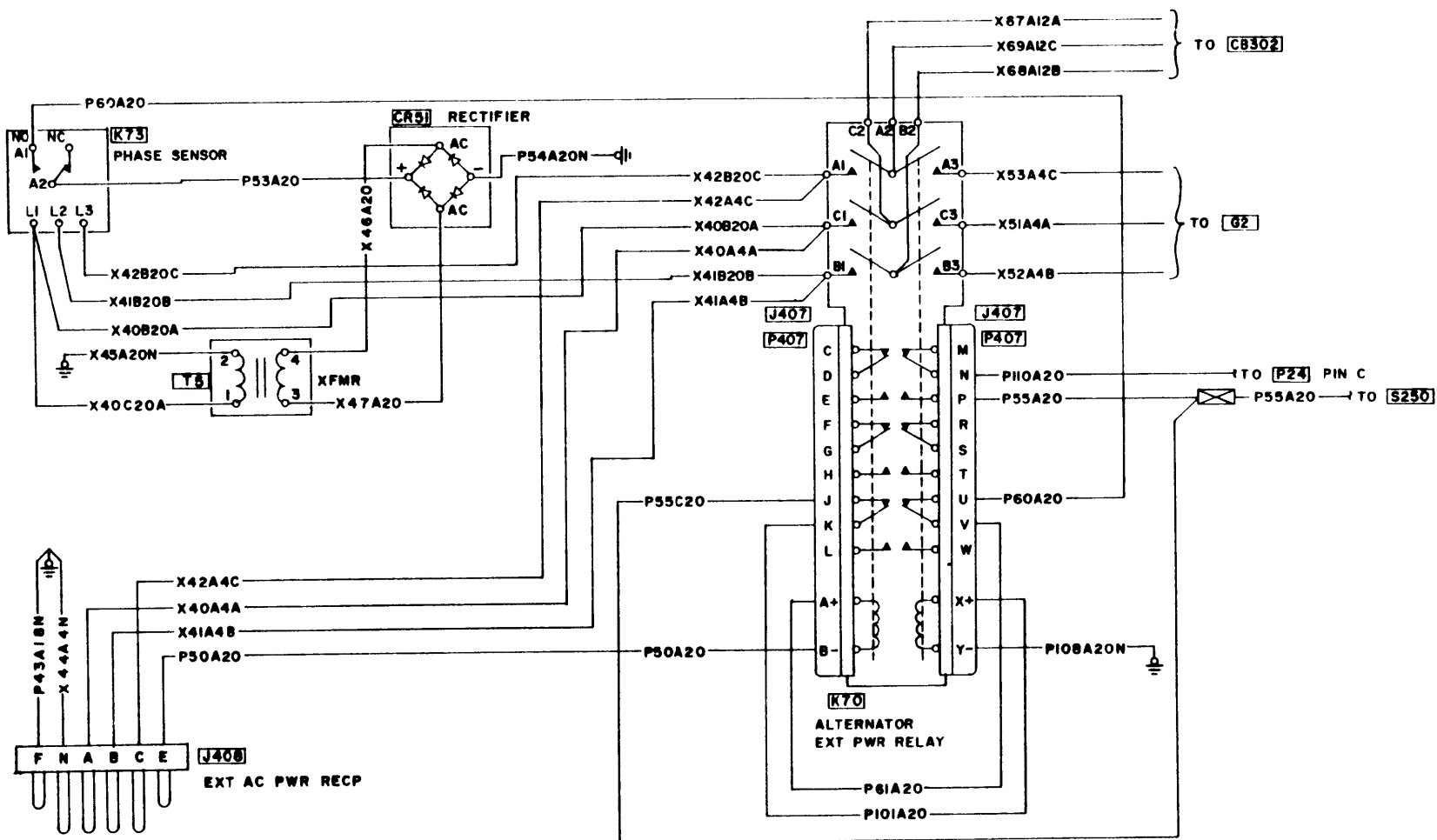


Figure F-19. External Power System

205475-126  
AV 054253

F-55/(F-56  
blank)









NOTE

ON EH-1H HELICOPTERS  
IF HELICOPTER IS A 1966 MODEL OR SUBSEQUENT AND THE AIRCRAFT HAS A STANDBY GENERATOR FIELD CONTROL RELAY INSTALLED THEN WIRE P-87A16 WILL BE CONNECTED TO TERMINAL F+/A ON THE STANDBY VOLT REG. INSTEAD OF WIRE P-35A16.

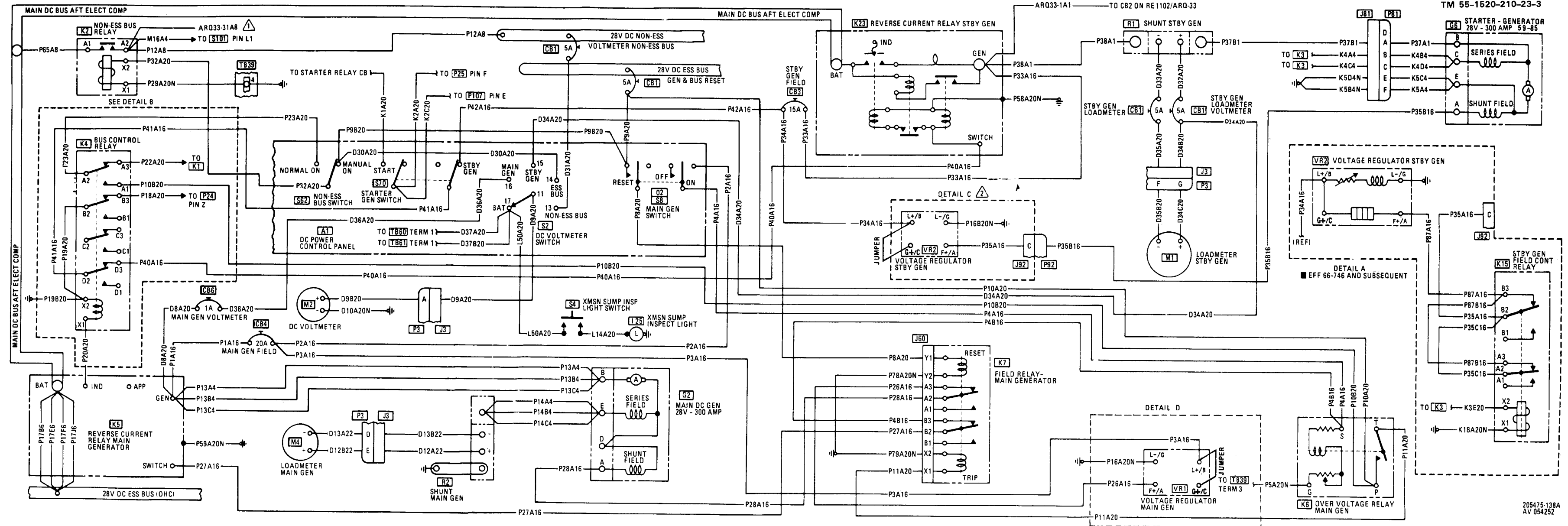
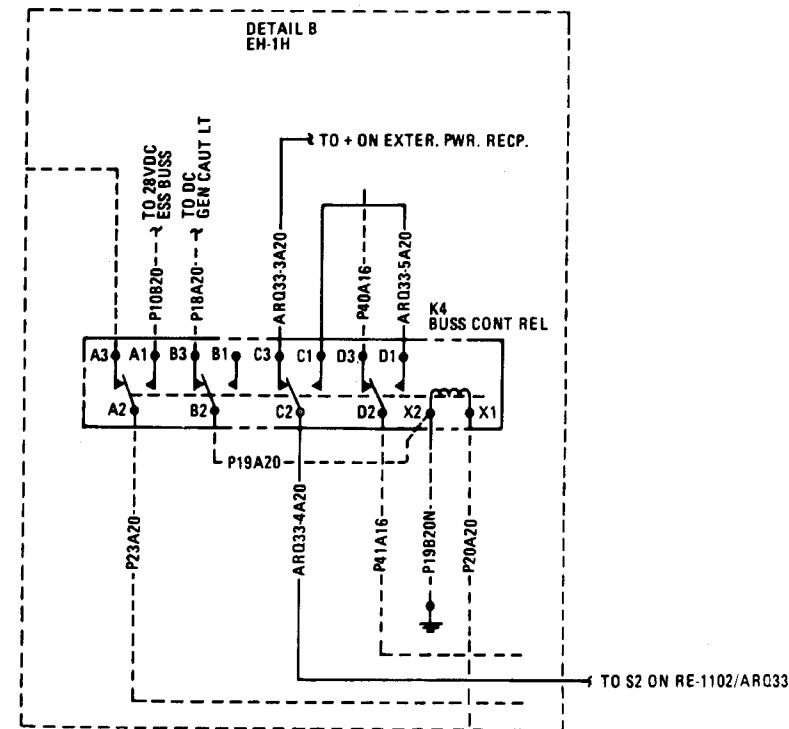


Figure F-20. Generator and Bus System

TM 55-1520-210-23-3

F-59/F-80 blank

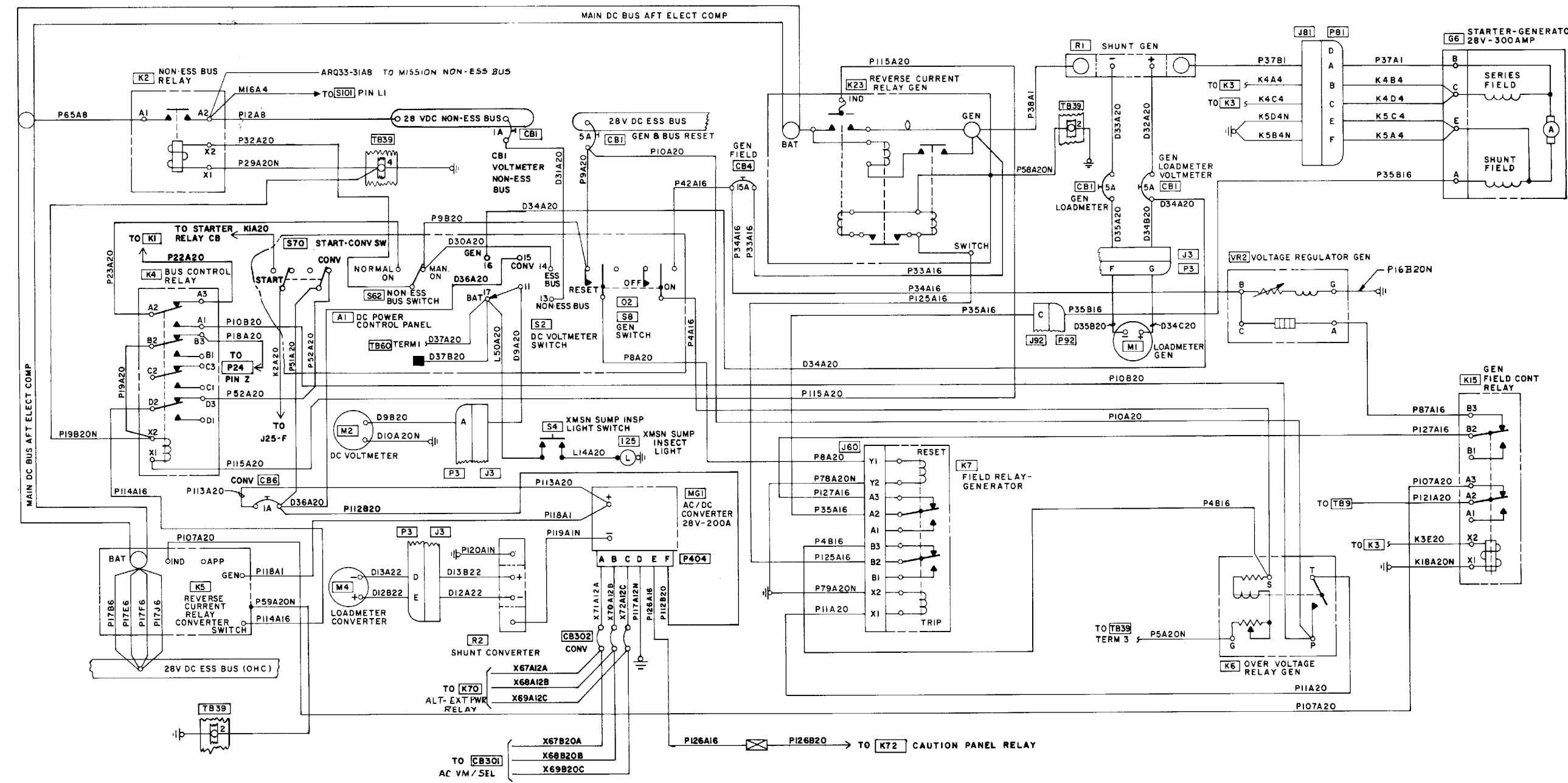


Figure F-20.1 Generator and bus system

F-61/(F-62 blank)







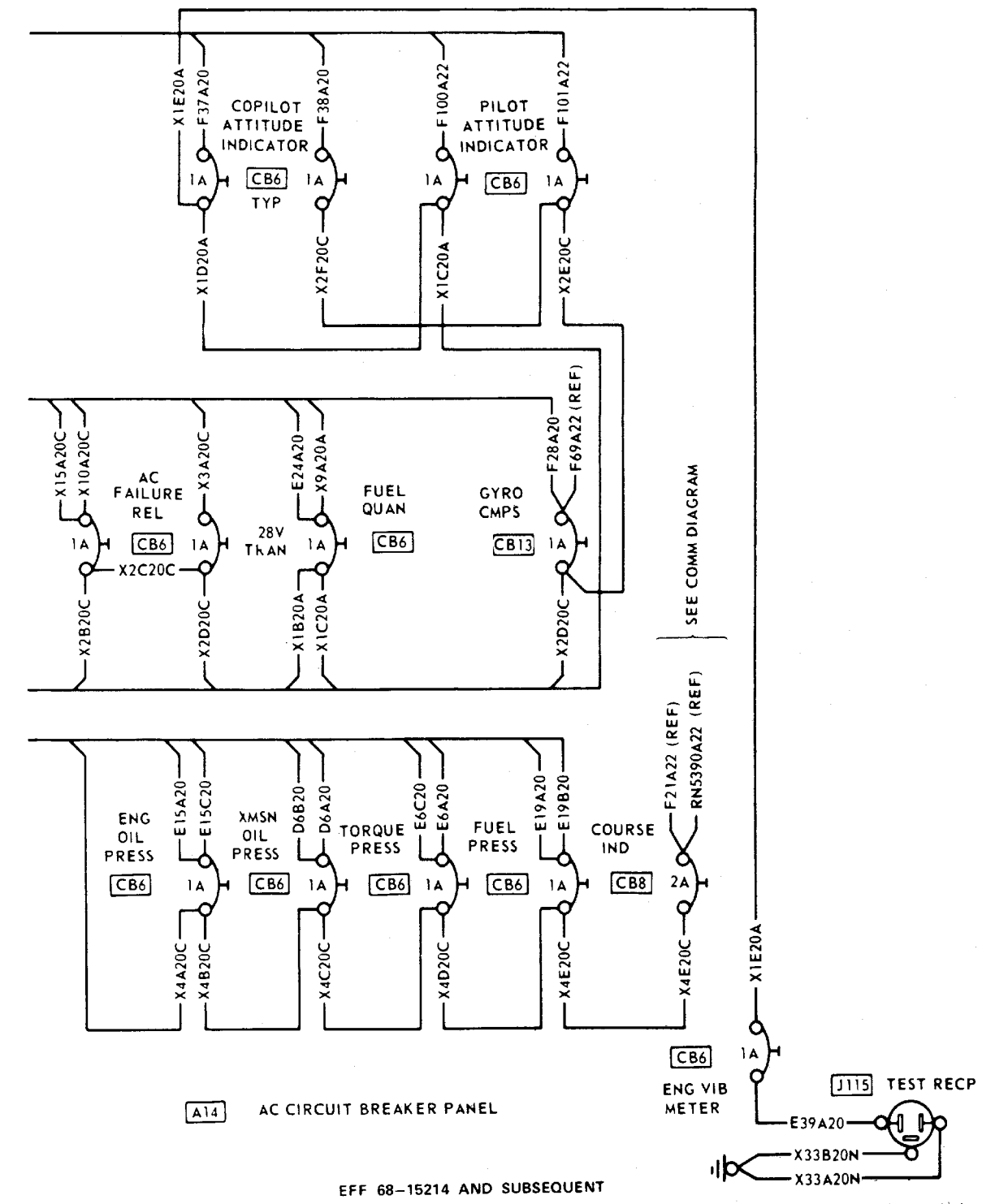
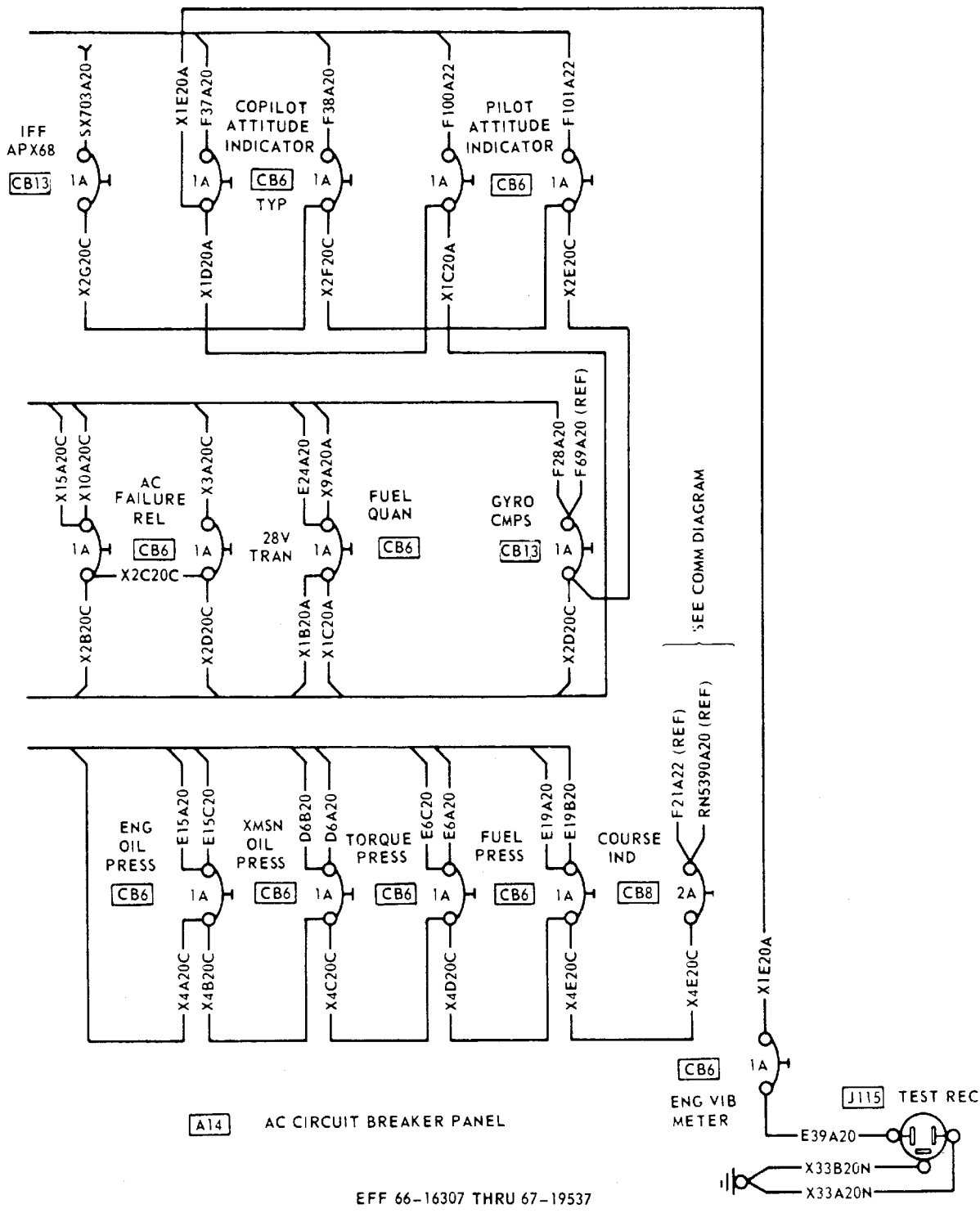
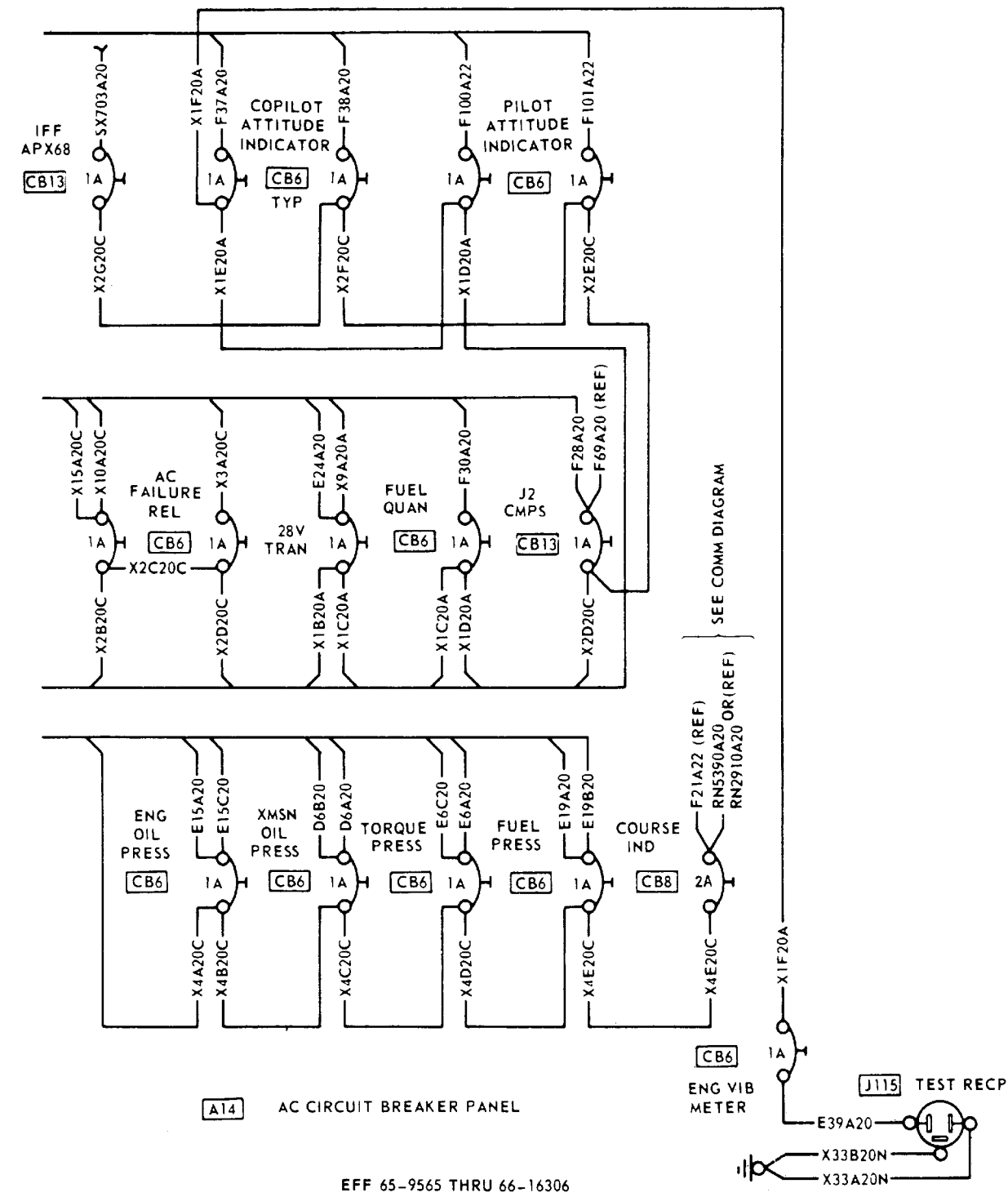
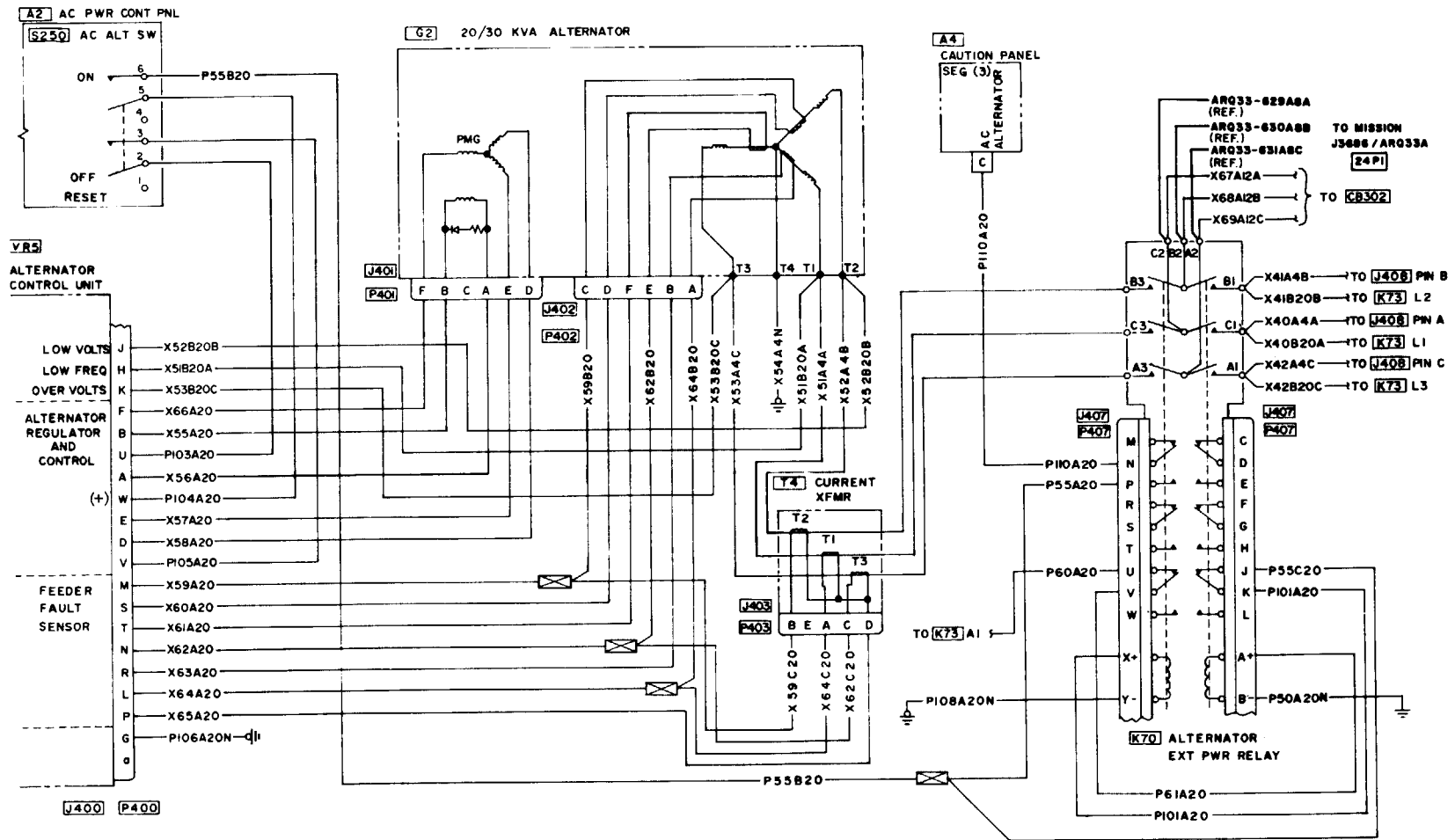


Figure F-21. AC power system (Sheet 2 of 2)





EB X Figure F-21.1 Alternator system



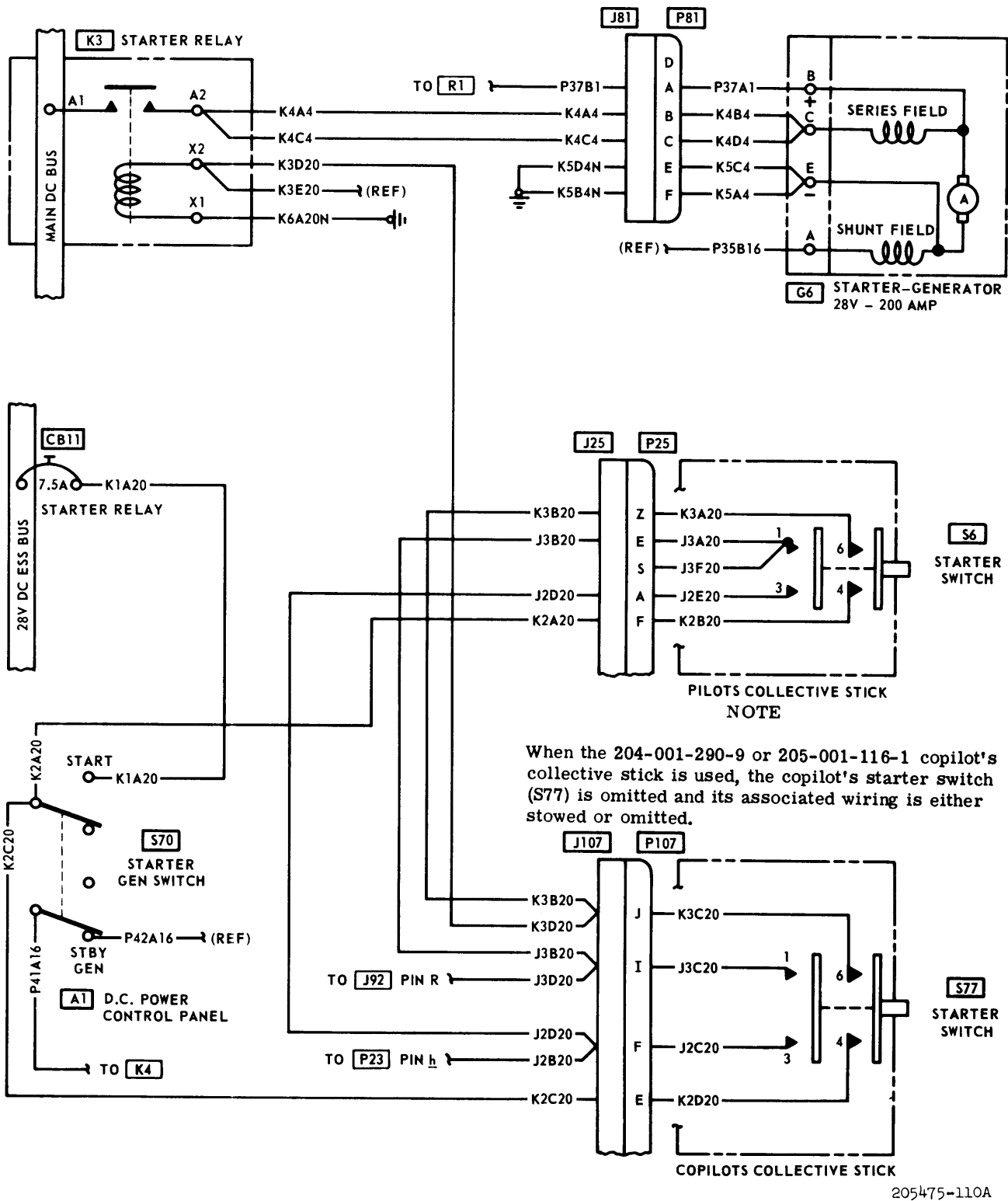


Figure F-22. Starter system (65-9566 through 67-19637) (Sheet 1 of 2)

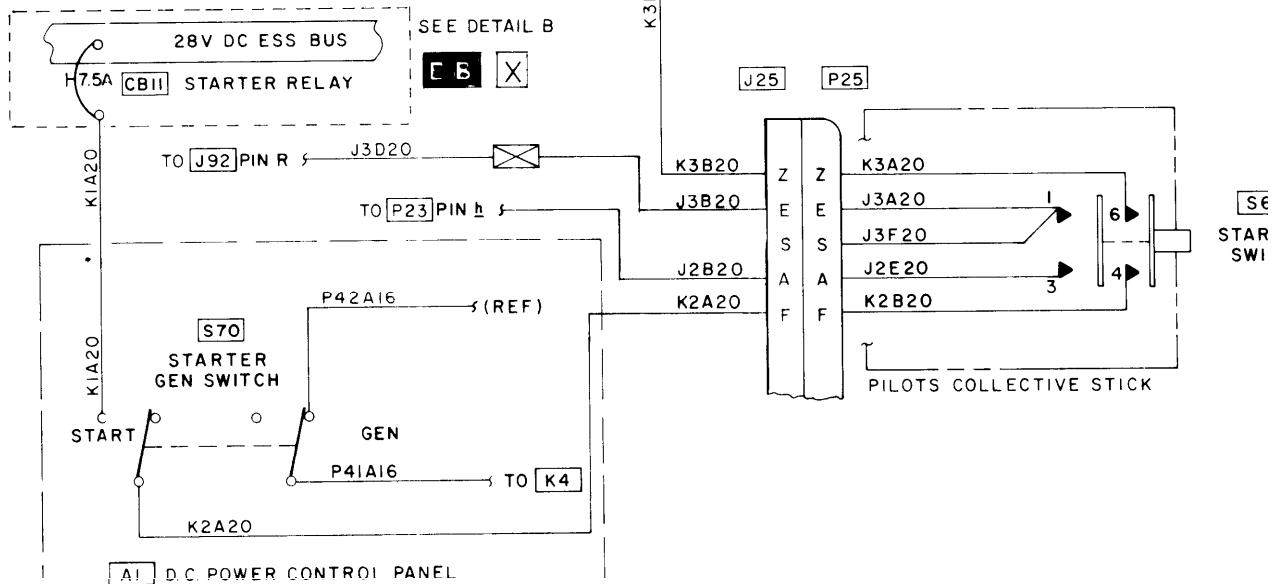
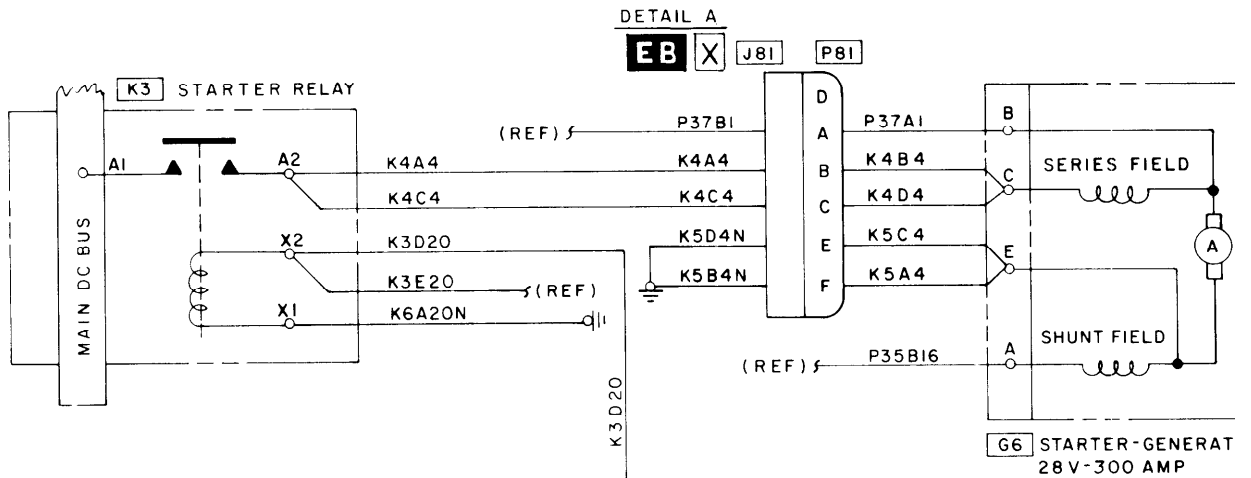
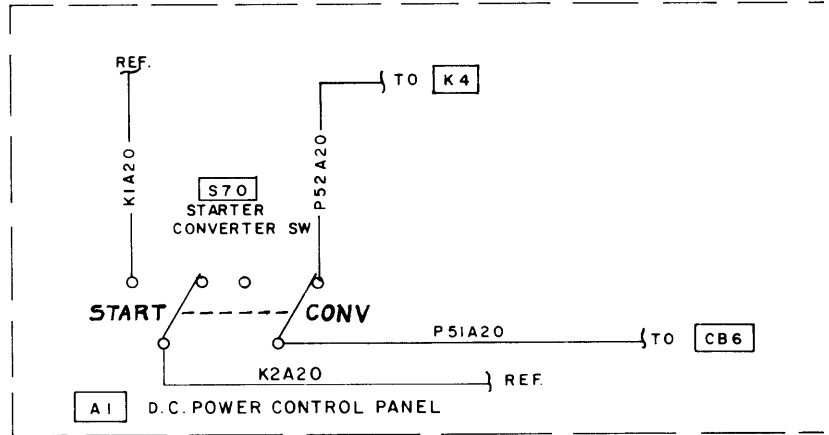
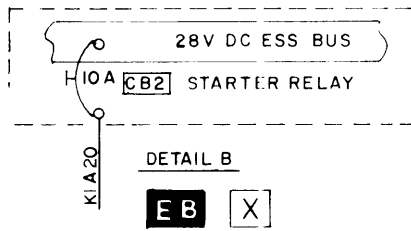
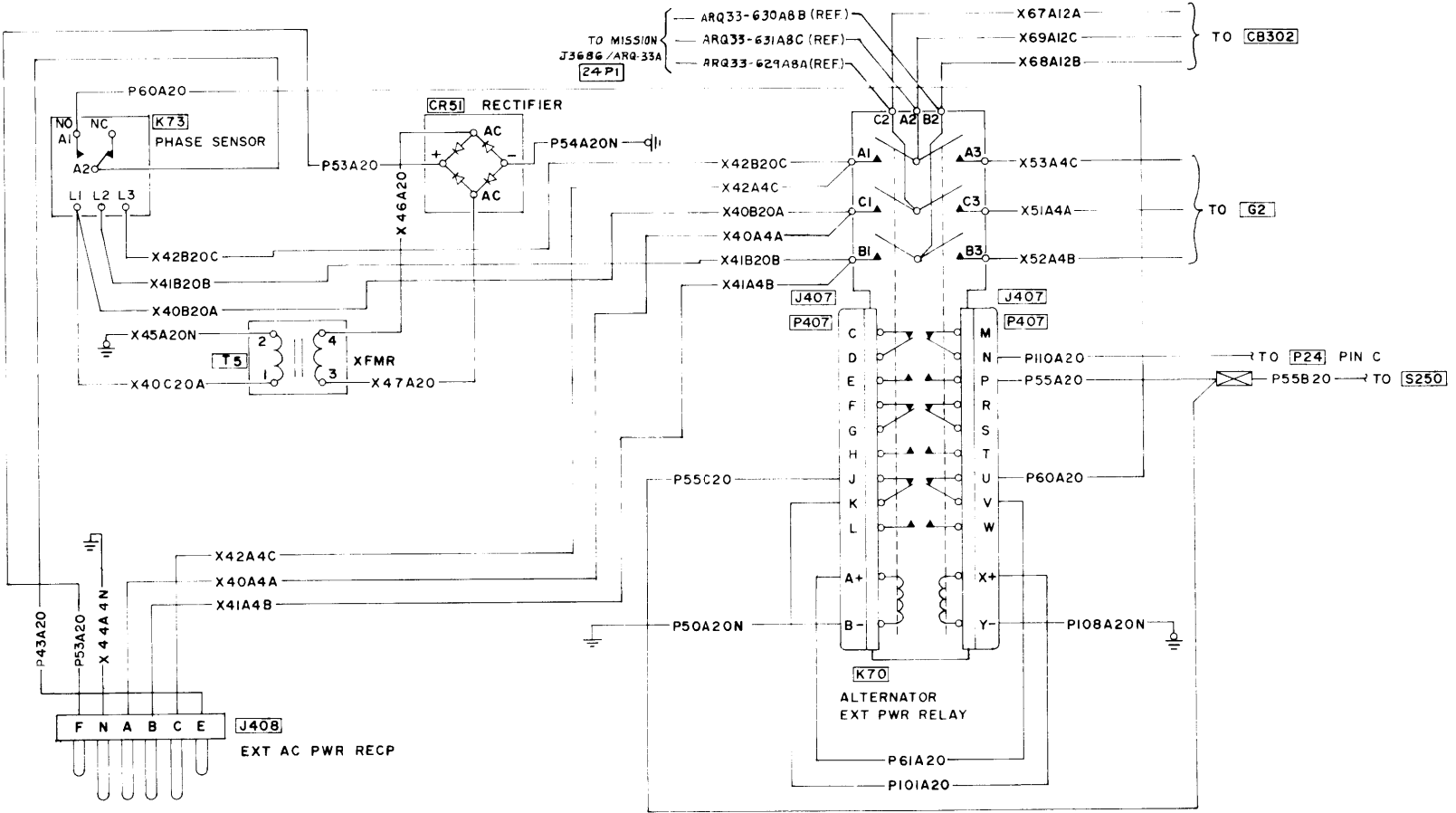
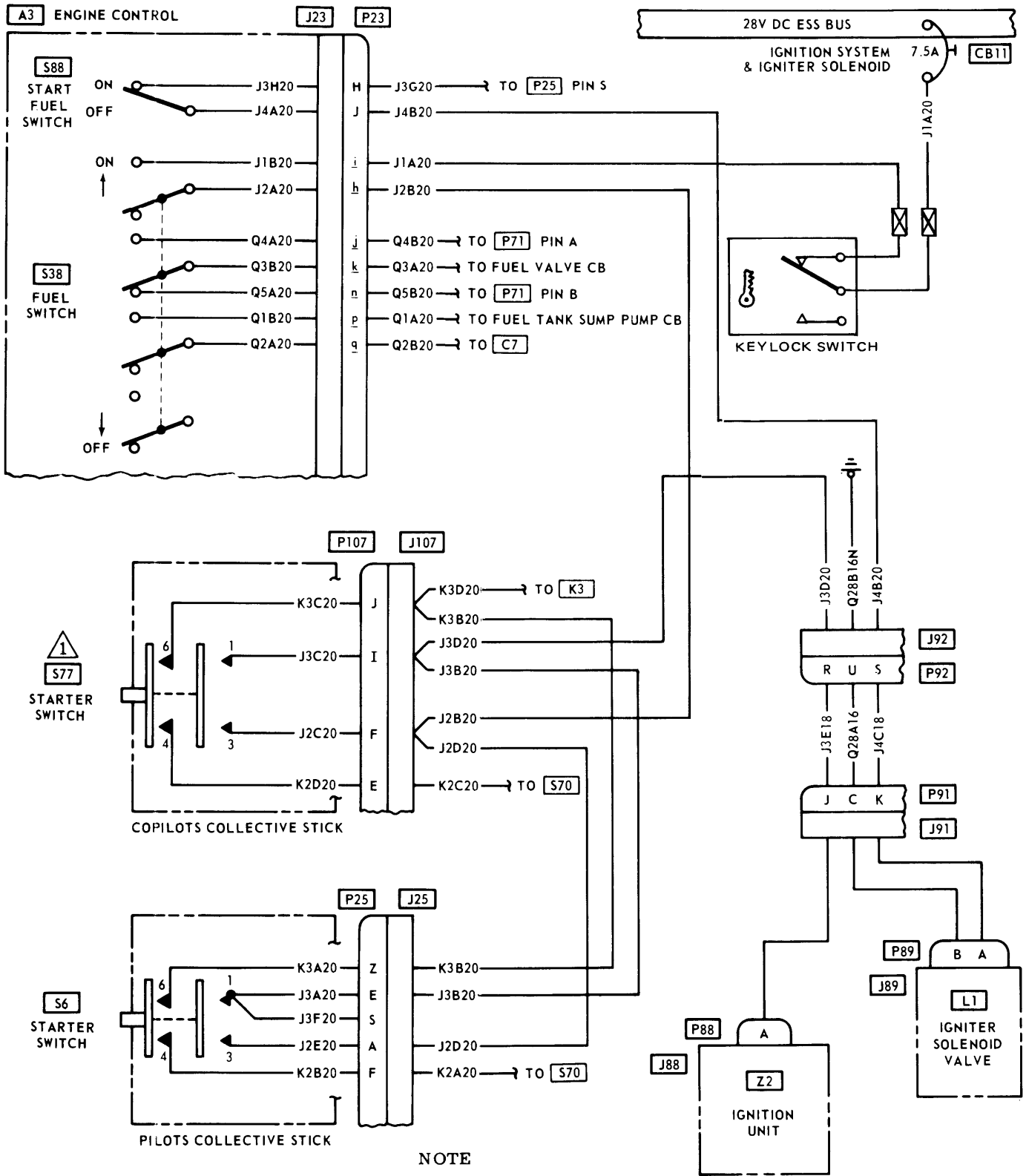


Figure F-22 Starter system (68-15214 and subsequent) (sheet 2 of 2)

Figure F-22.1 External 3 phase power system X

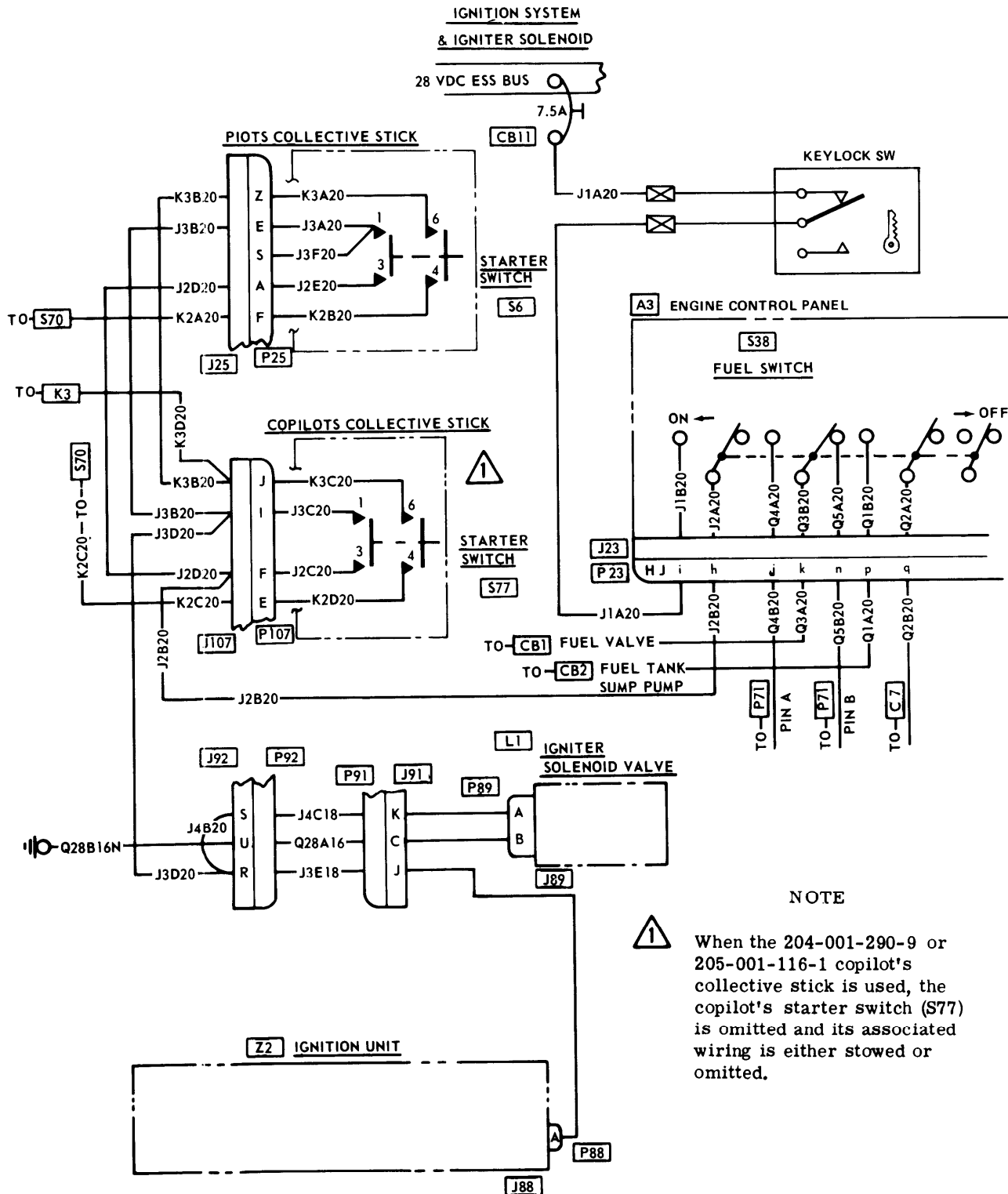




① When the 204-001-290-9 or 205-001-116-1 copilot's collective stick is used, the copilot's starter switch (S77) is omitted and its associated wiring is either stowed or omitted.

205475-109B  
AV 054259

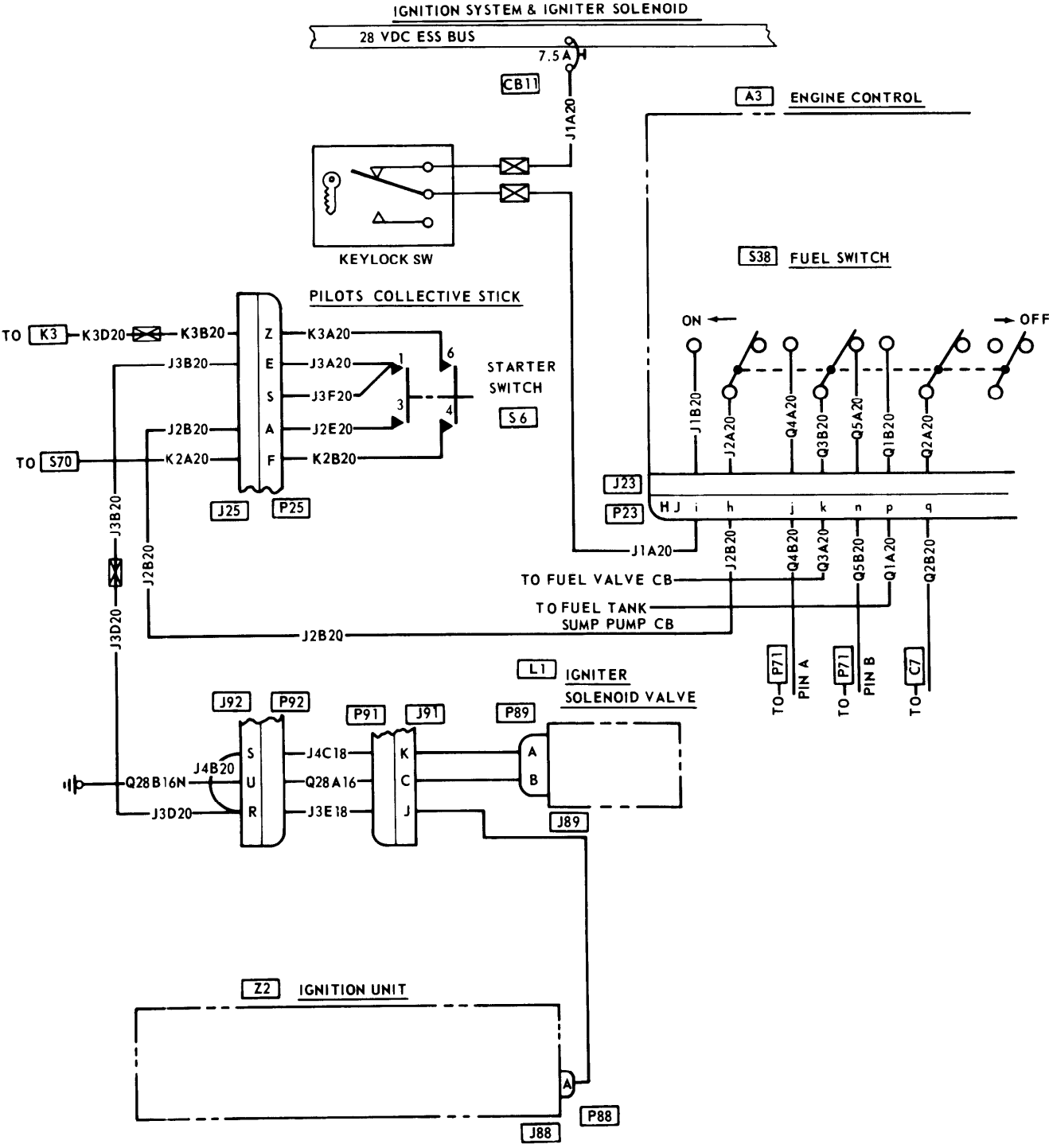
Figure F-23. Ignition system (65-9565 through 66-16033) (Sheet 1 of 3)



EFF 66-16034 THRU 67-19537

205475-143B  
AV 054260

Figure F-23. Ignition system (66-16034 through 67-19537) (Sheet 2 of 3)



205475-142B  
AV 054261

Figure F-23. Ignition system (68-15214 and subsequent) (Sheet 3 of 3)

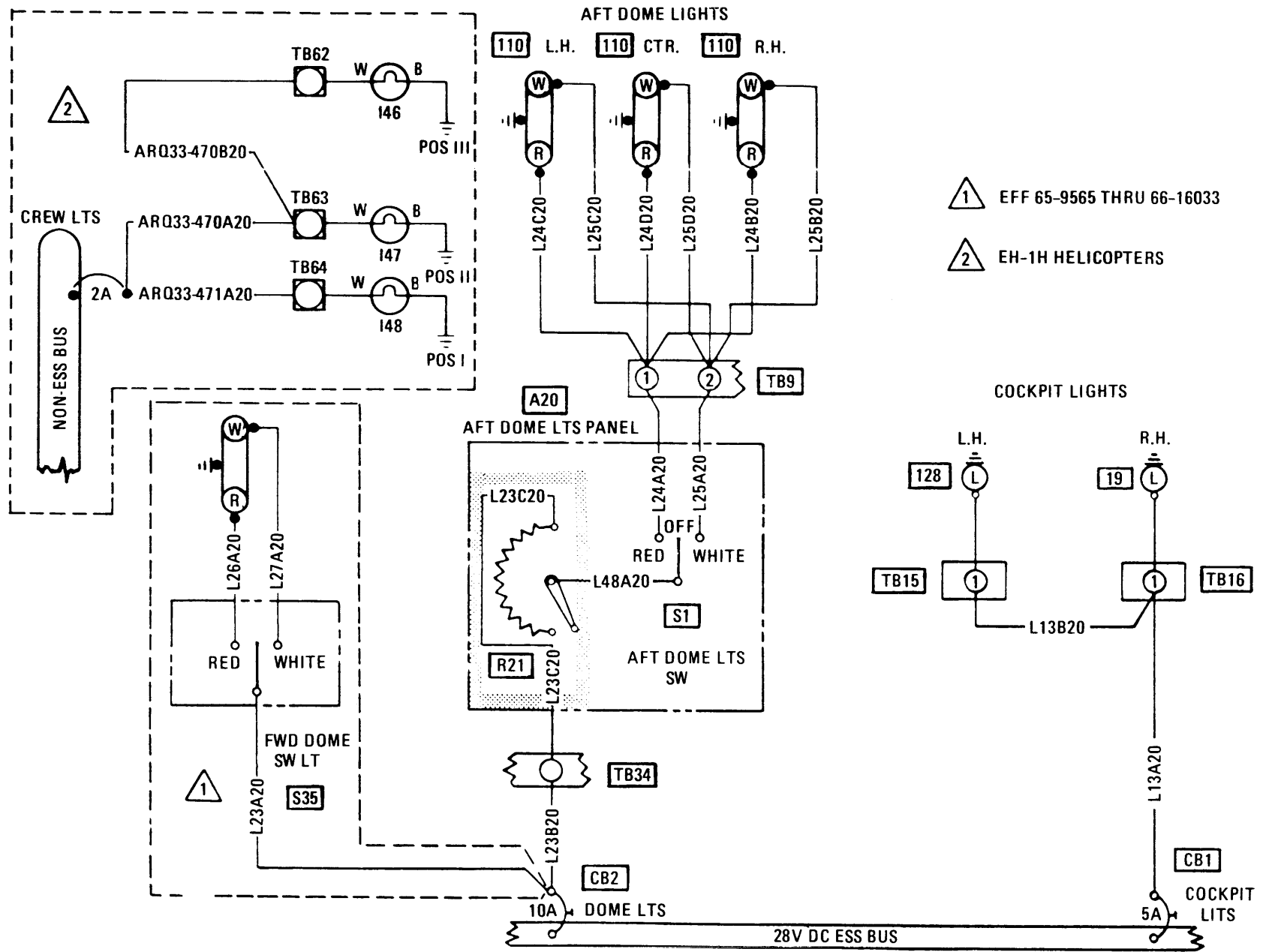


Figure F-24. Cockpit, Dome and Crew Lights System

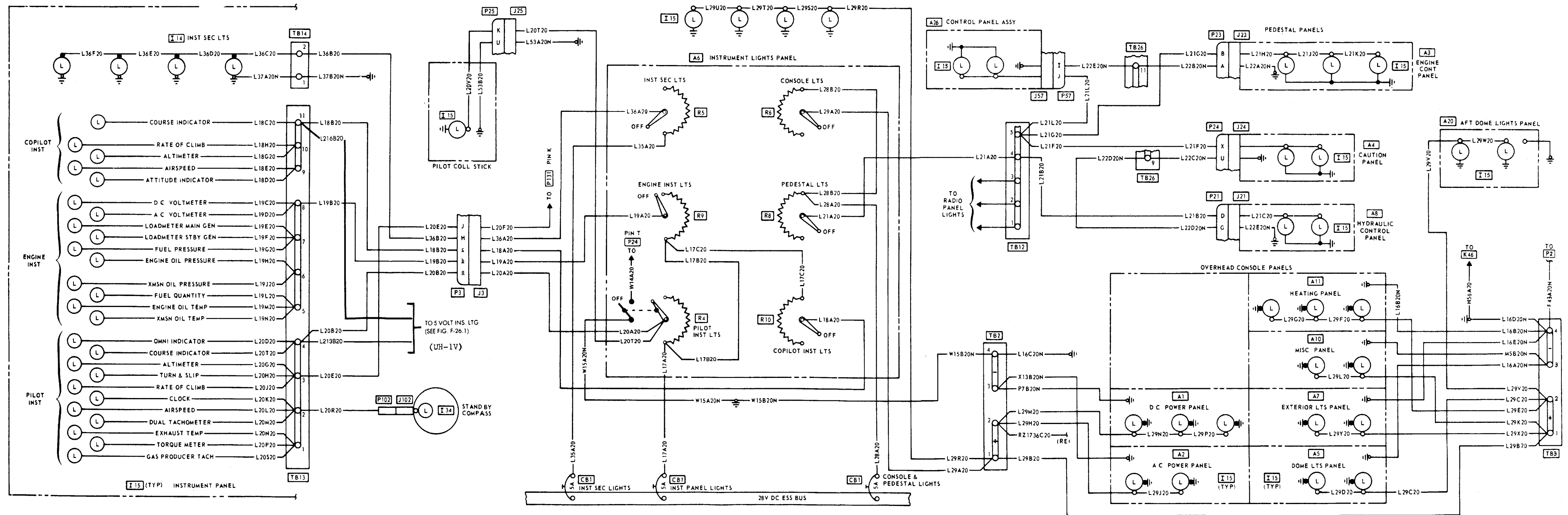
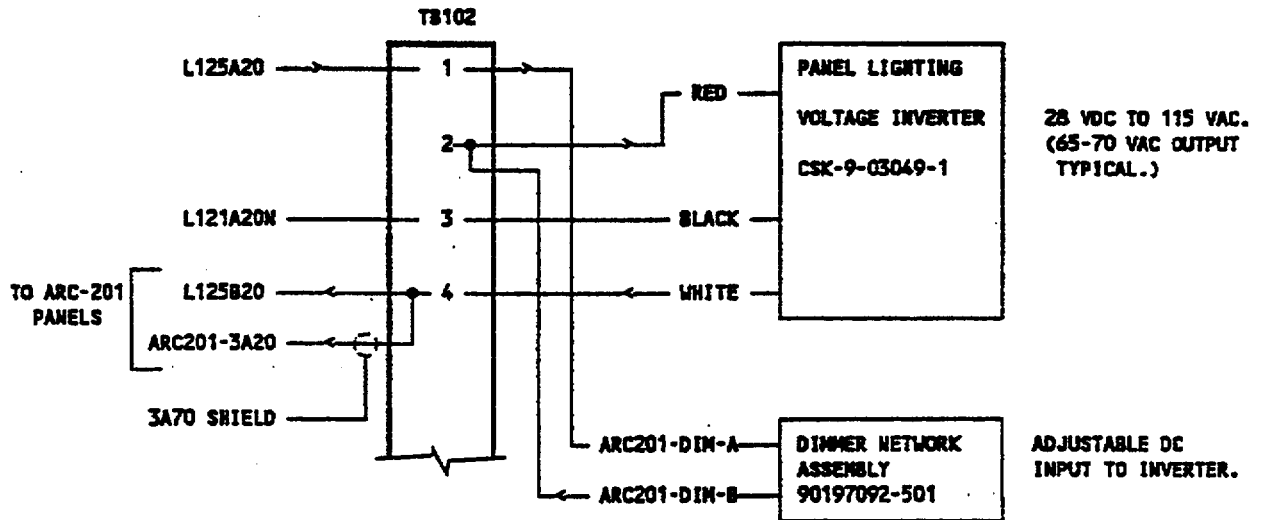


Figure F-25. Instrument, Console, and Pedestal Lights System

Change 4 F-75/(F-76 blank)





REFERENCE: INSTRUMENT, CONSOLE AND PEDESTAL LIGHTING SYSTEM DIAGRAM

NOTE: SEE TM 11-1520-210-23 FOR PROCEDURE TO ADJUST ARC-201 PANEL VOLTAGE.

Figure F-25.1. ARC-201 Panel Lighting Wiring Diagram  
(After application MWO 55-1520-210-50-21)

Change 8 F-76.1(F-76.2 blank)

REFERENCE: TM 55-1520-210-23  
 FIGURE F-25  
 INST. CONSOLE & PED.

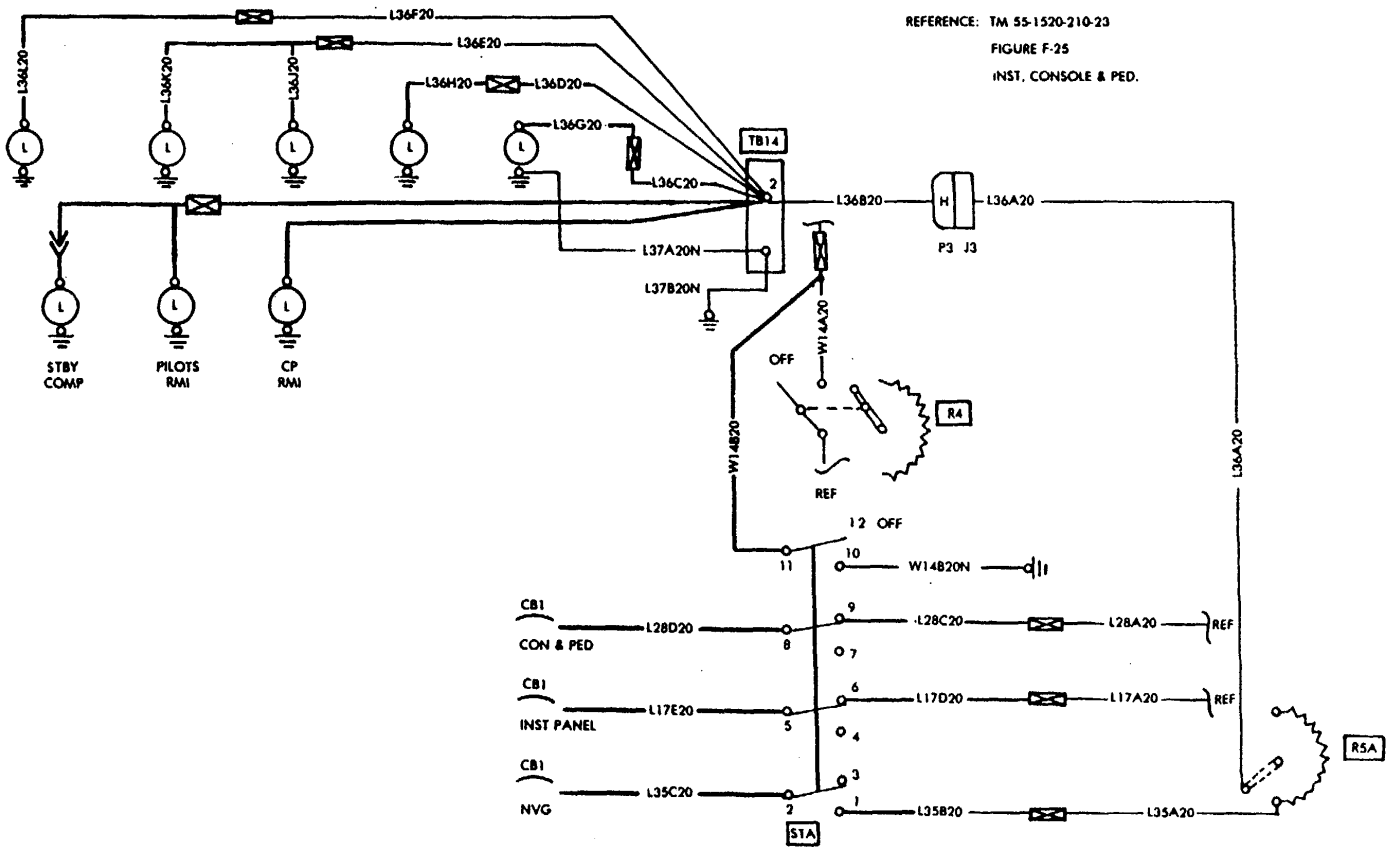
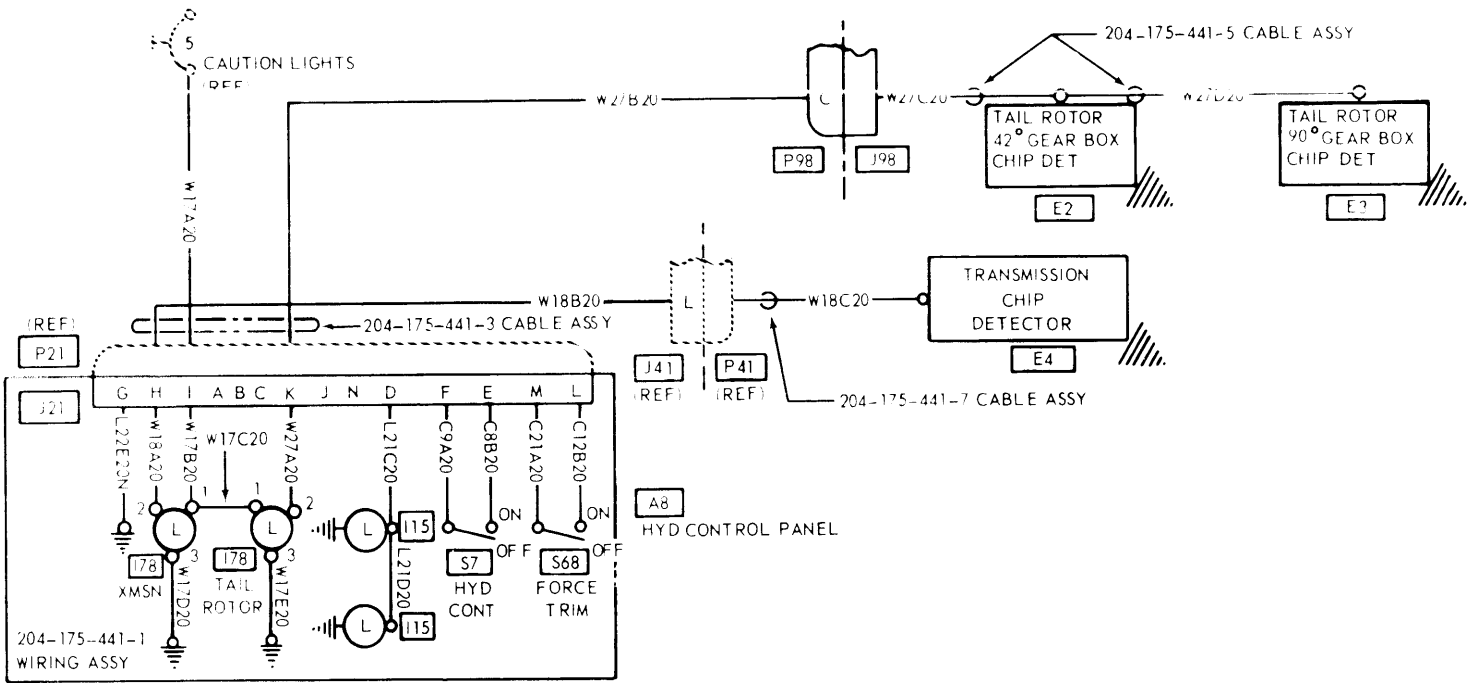


Figure F-25.2. Night Vision Goggles (Night Fix-Phase I) Lights System



204-175-441-1  
AV 03 285

Figure F-26. Caution lights system (60-6028 through 64-13901)  
(Sheet 1 of 3)

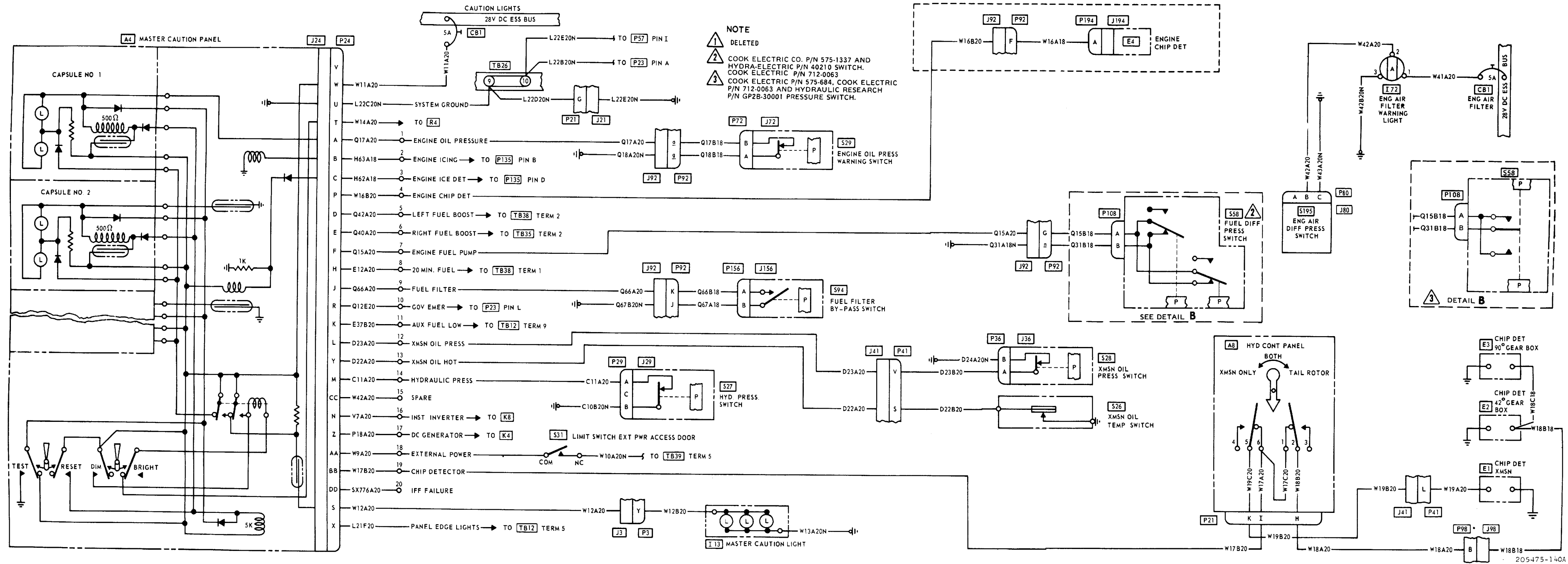
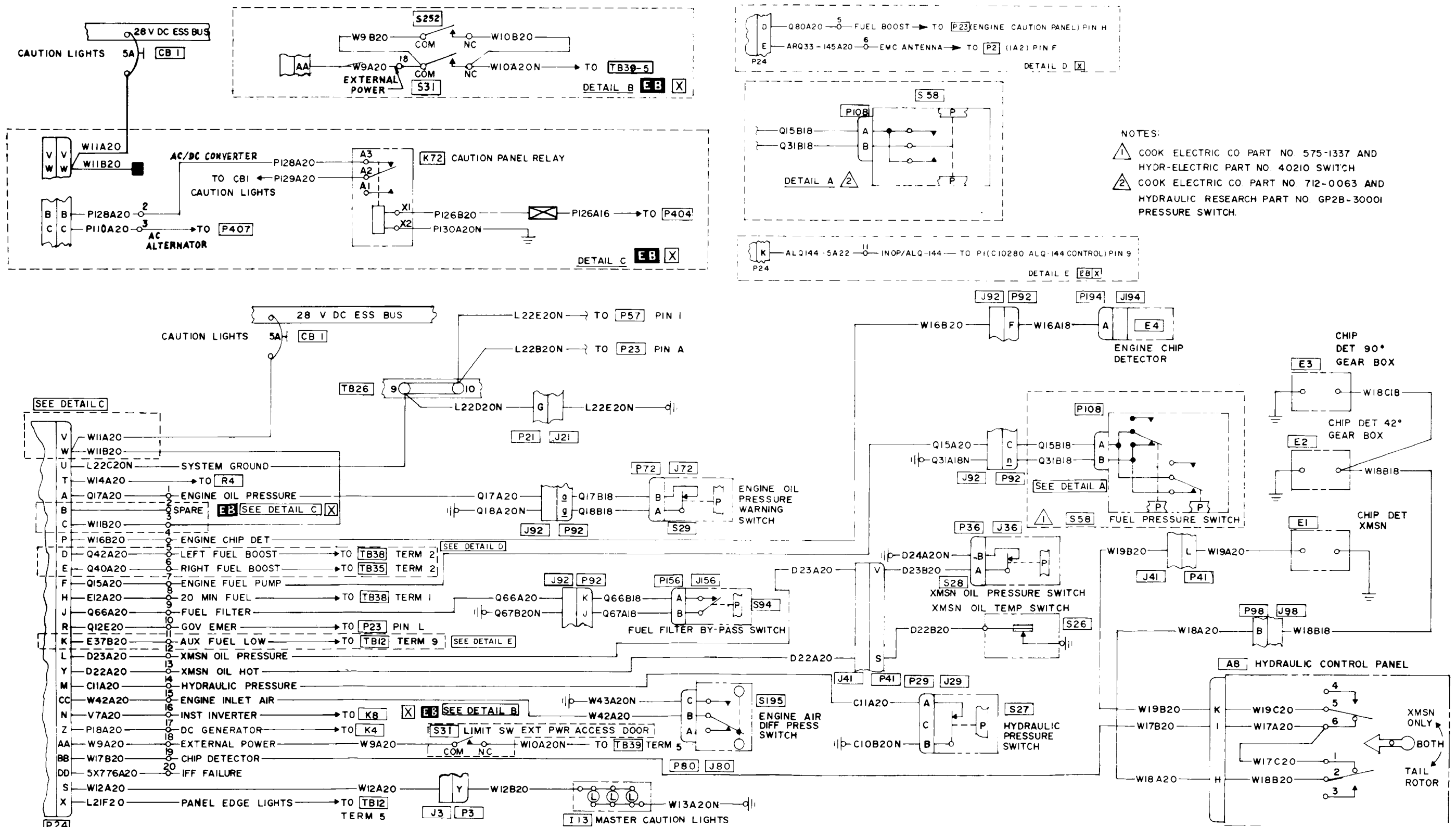


Figure F-26. Caution lights system (65-9565 through 66-16867) (Sheet 2 of 3)





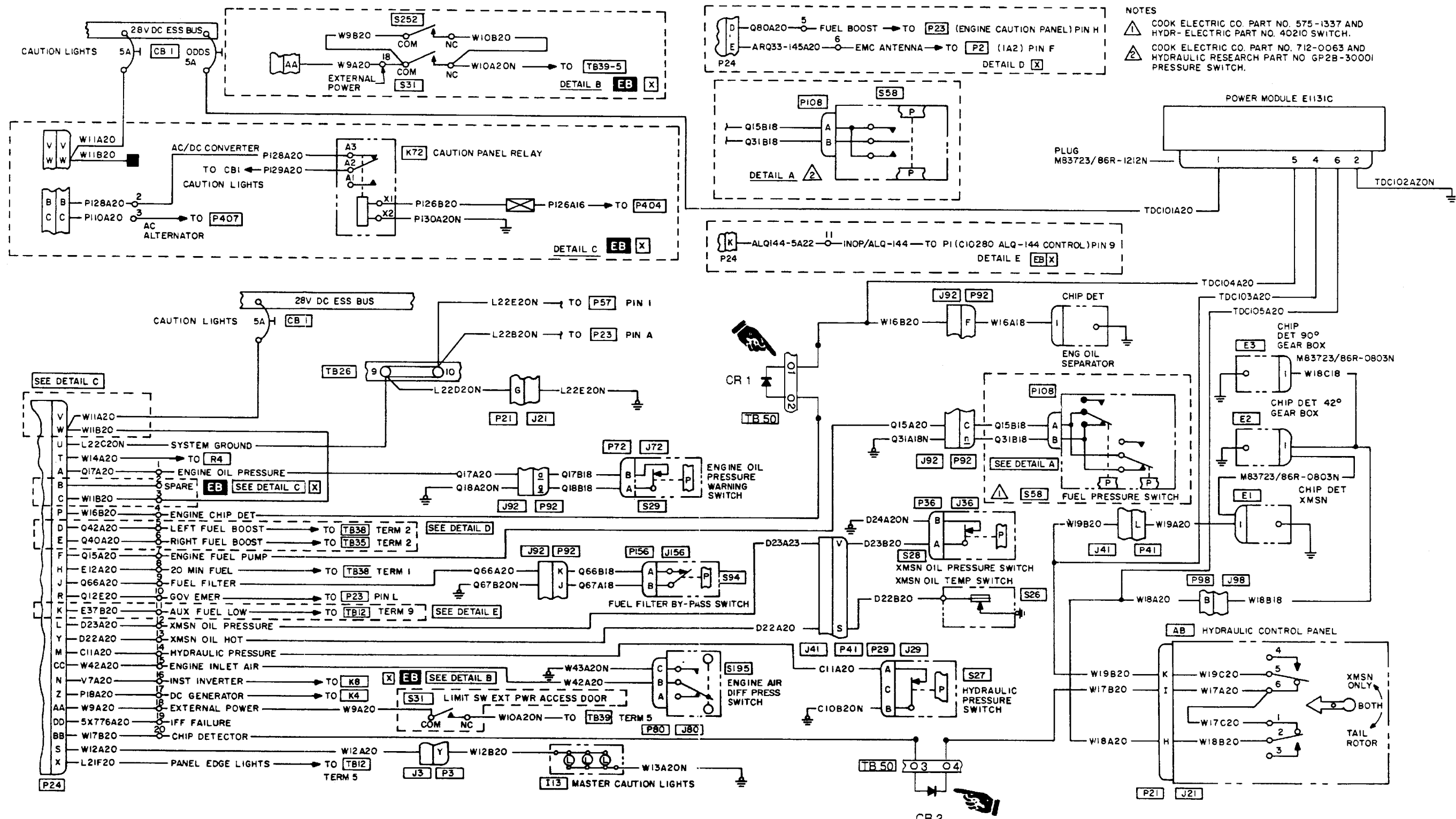
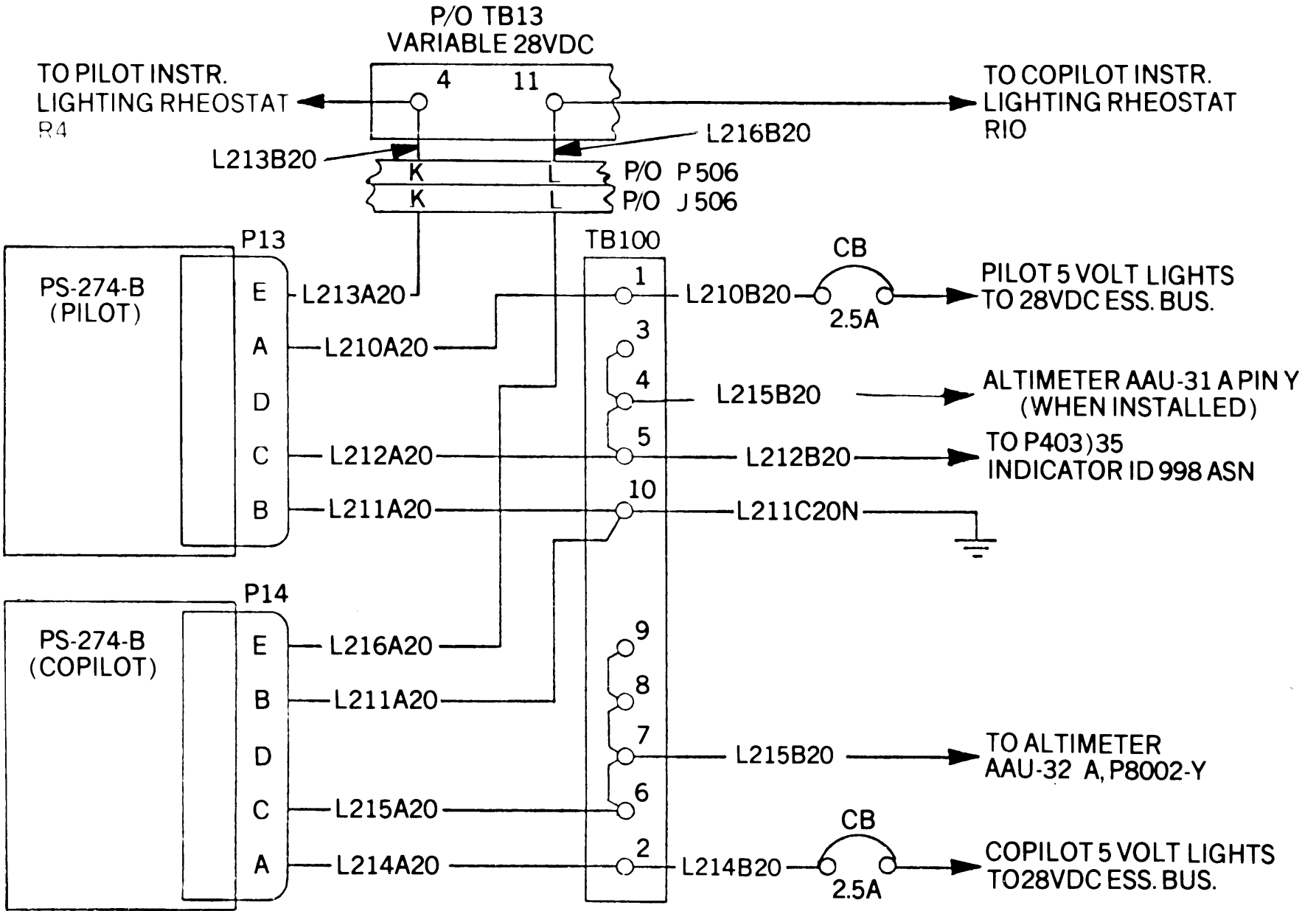






Figure F-26.1. 5 VOLT Instrument Lighting System (UH-1V)





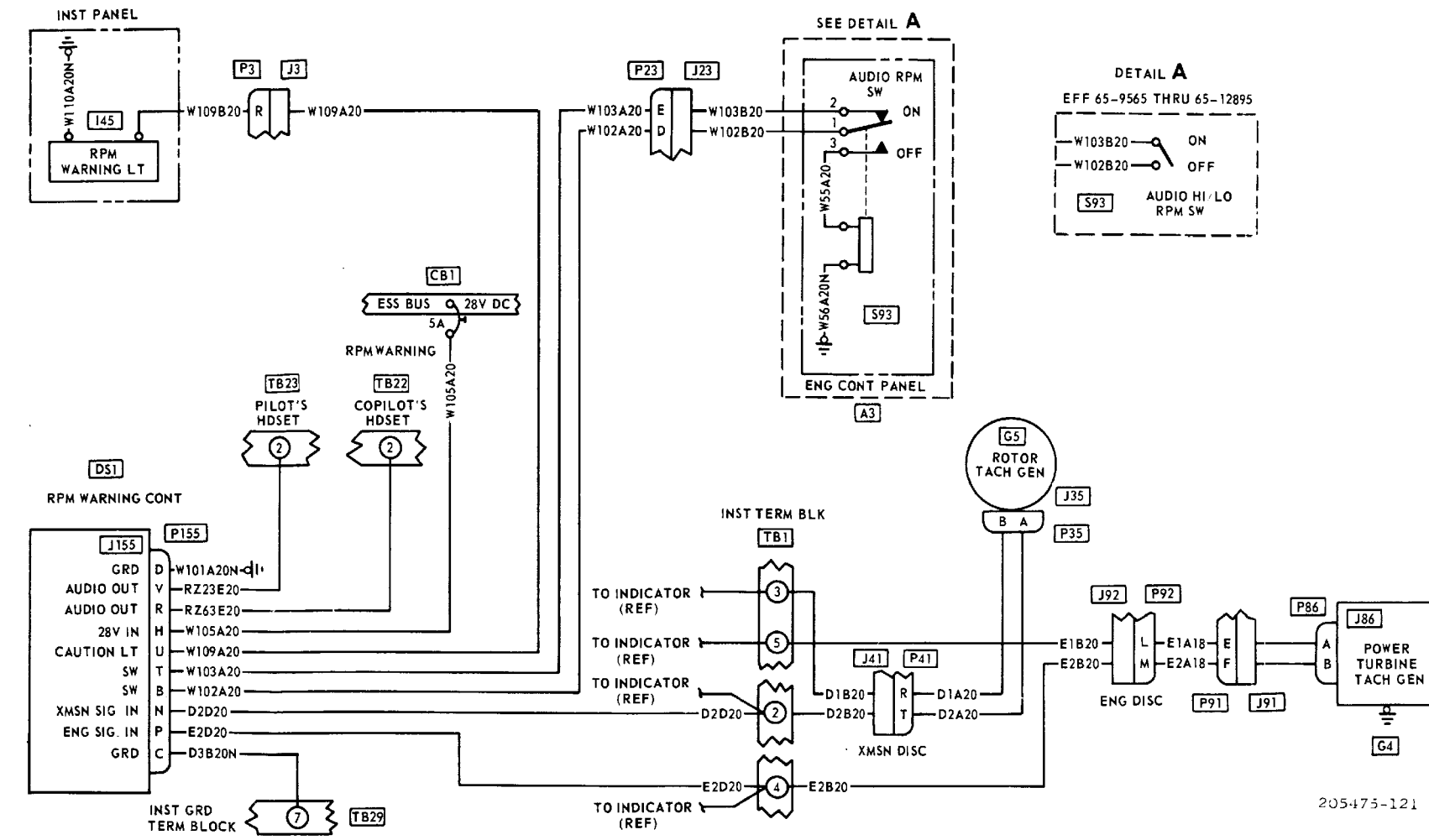
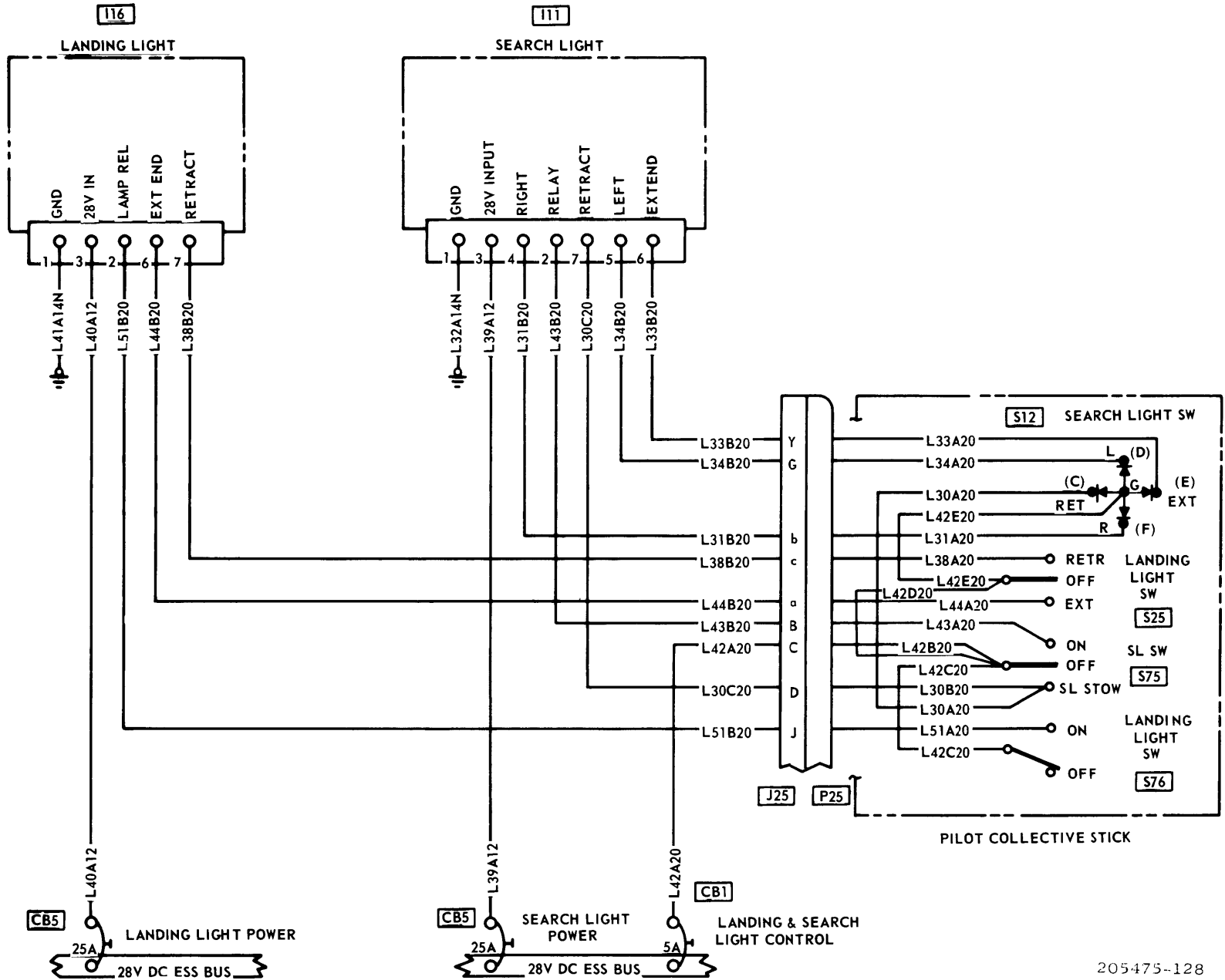


Figure F-27. RPM warning system

F-85/(F-86 blank)



Figure F-28. Landing and searchlight system



205475-128  
AV 054273

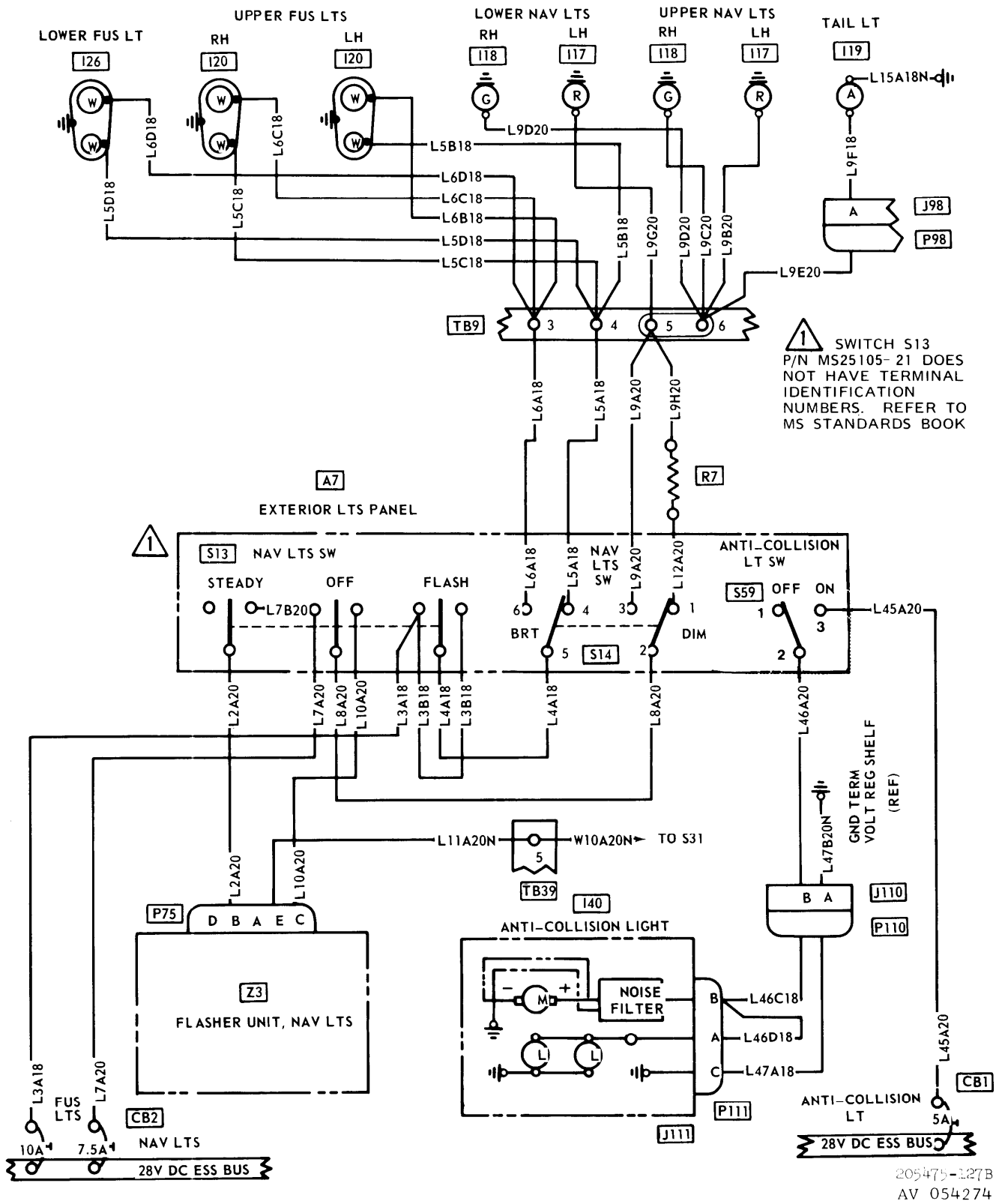
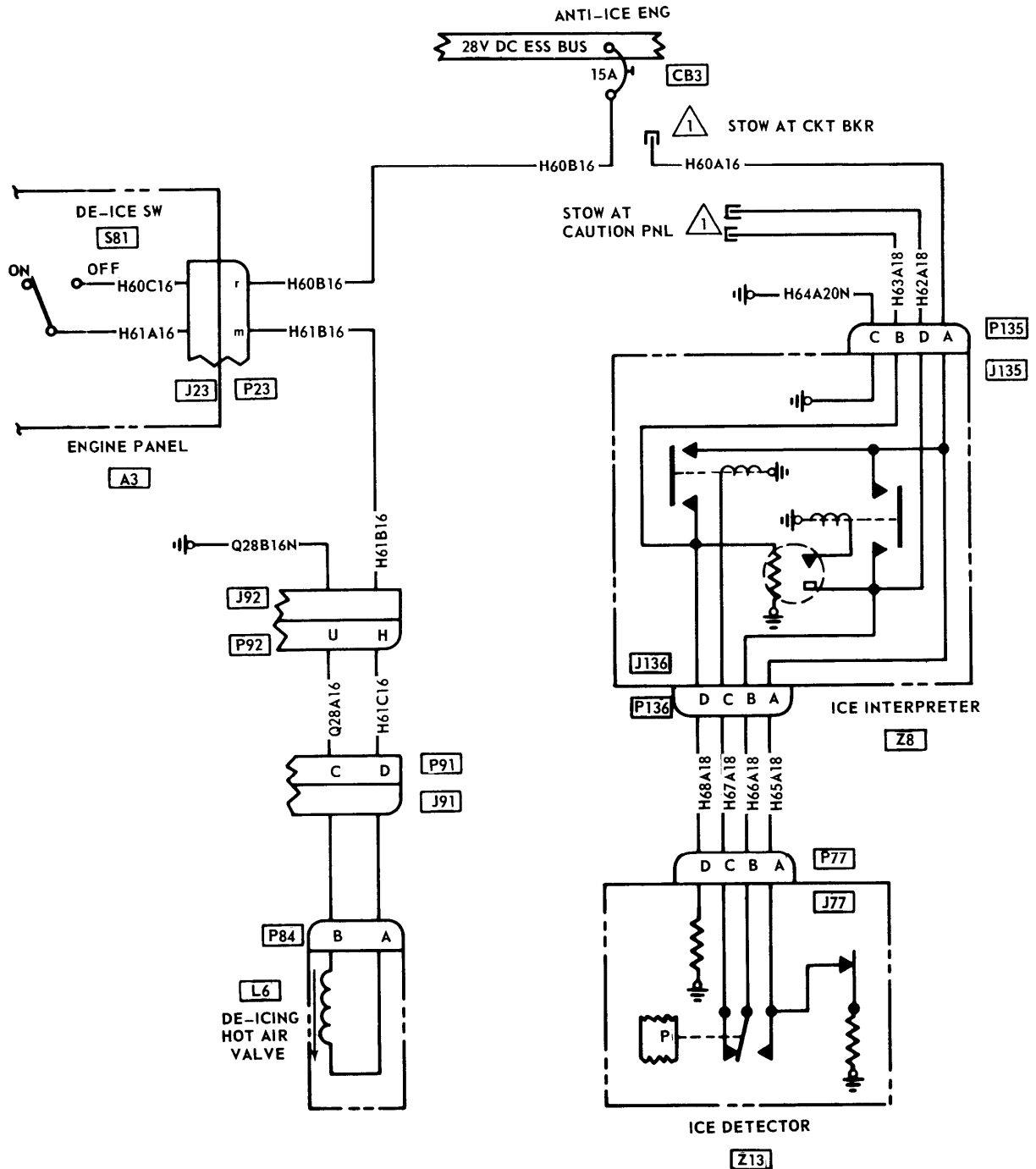


Figure F-29. Navigation, fuselage, and anti-collision lights system

205475-127B  
AV 054274

**⚠** THE ENGINE ICE DETECTOR SYSTEM IS NOT OPERATIVE WITH SAND AND DUST SEPARATOR INSTALLED. EFFECTIVE 65-9565 THRU 66-16867 AND OTHER HELICOPTERS SO MODIFIED - WIRE H60A16 CONNECTED TO CIRCUIT BREAKER, WIRE H62A18 CONNECTED TO PIN C, P24, WIRE H63A18 CONNECTED TO PIN B, P24.



205475-123A  
AV 054270

Figure F-30. De-ice and ice detector system





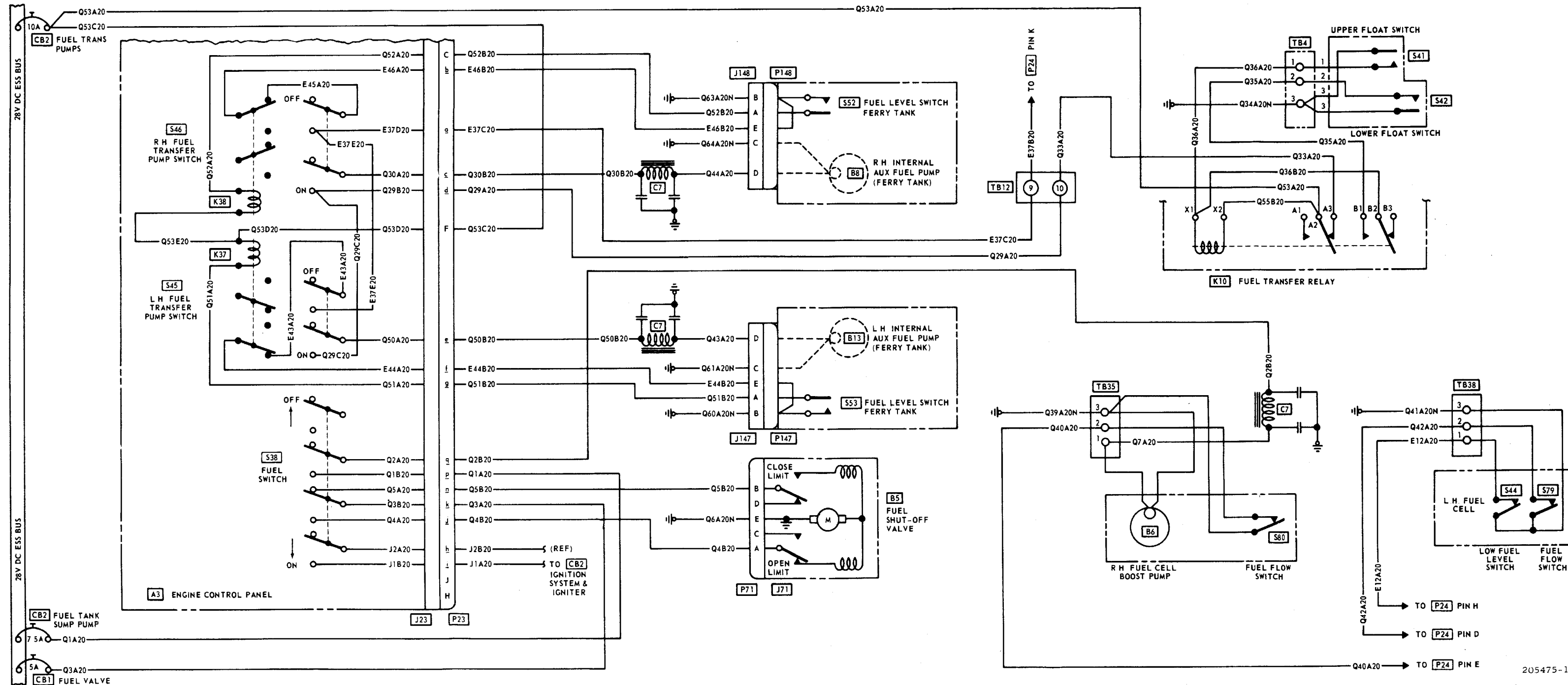
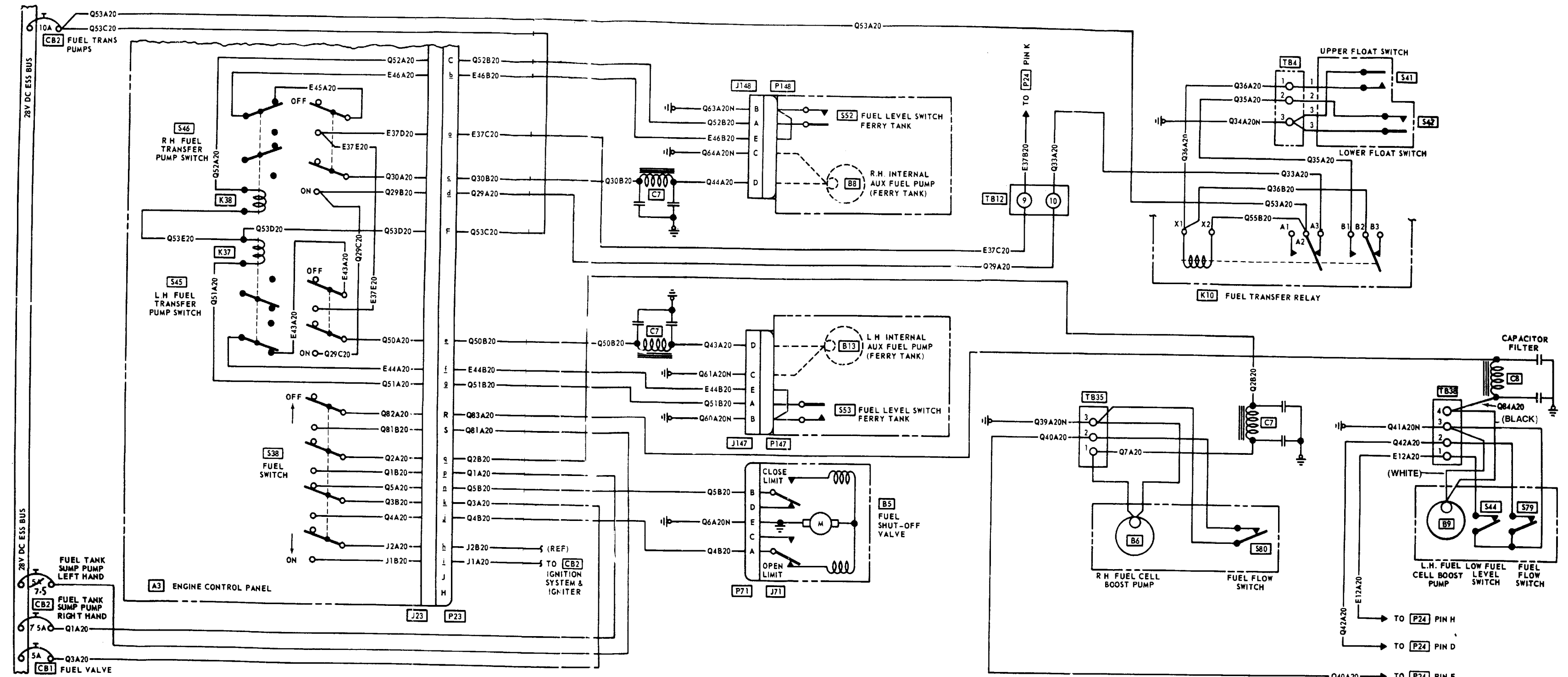


Figure F-31. Fuel boost and fuel valve system (Sheet 1 of 2)

205475-141

F-91/(F-92 blank)



205475-141-2

Figure F-31. Fuel boost and fuel valve system (Sheet 2 of 2)



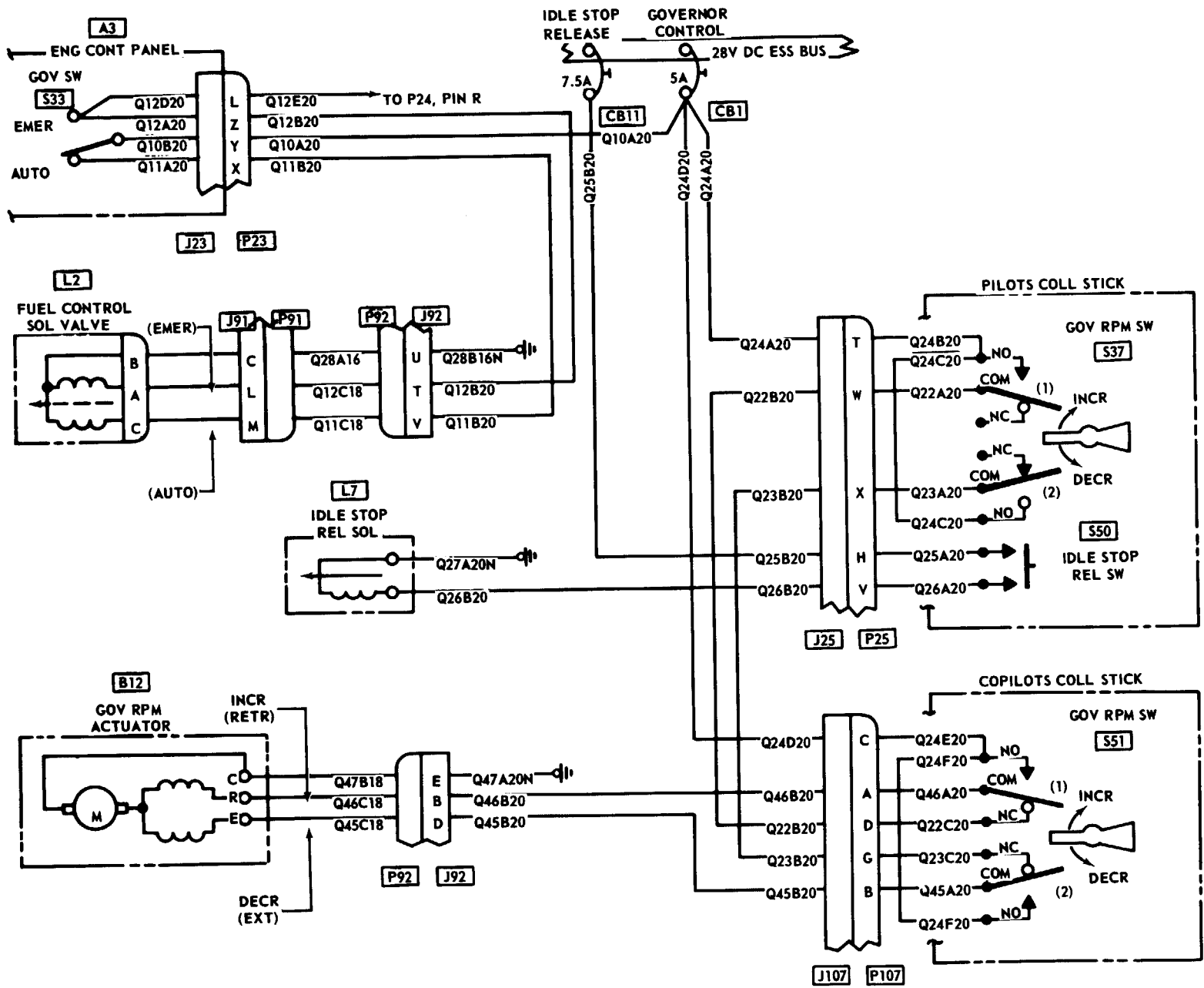


Figure F-32. Governor control and idle atop systems

F-95/(F-96  
blank)

205475-117  
AV 054263

TMI 55-1520-210-23-3



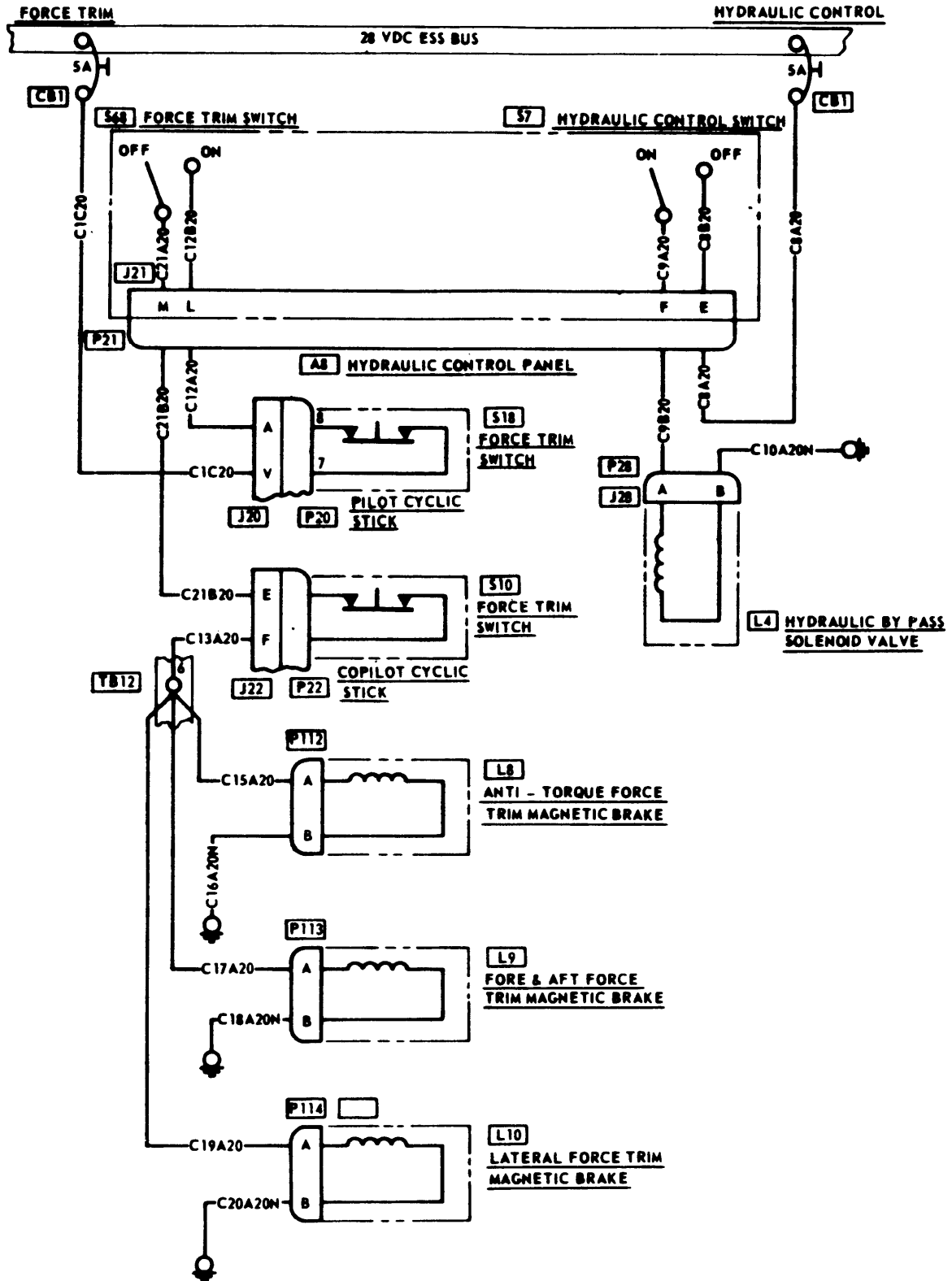
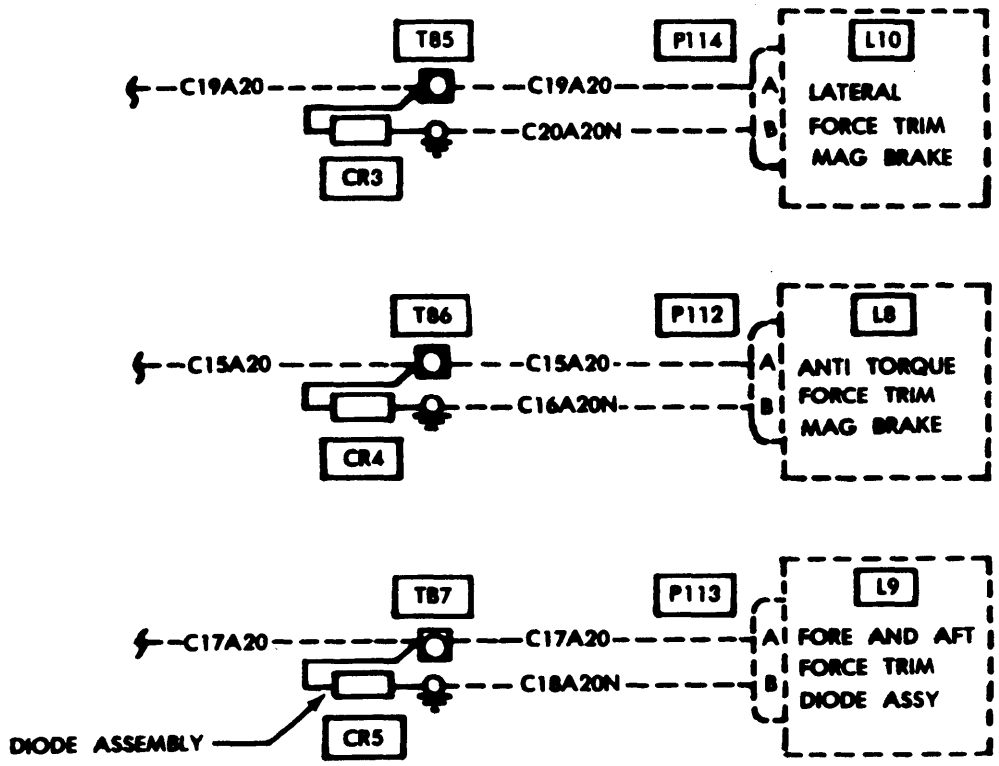


FIGURE F-33. FORCE TRIM AND HYDRAULIC CONTROL SYSTEM (SHEET 1 OF 2)



NOTE: WIRING DIAGRAM WHEN PROVISIONS FOR AN/APR-39 ARE INSTALLED

FIGURE F-33. FORCE TRIM AND HYDRAULIC CONTROL SYSTEM (SHEET 2 OF 2)

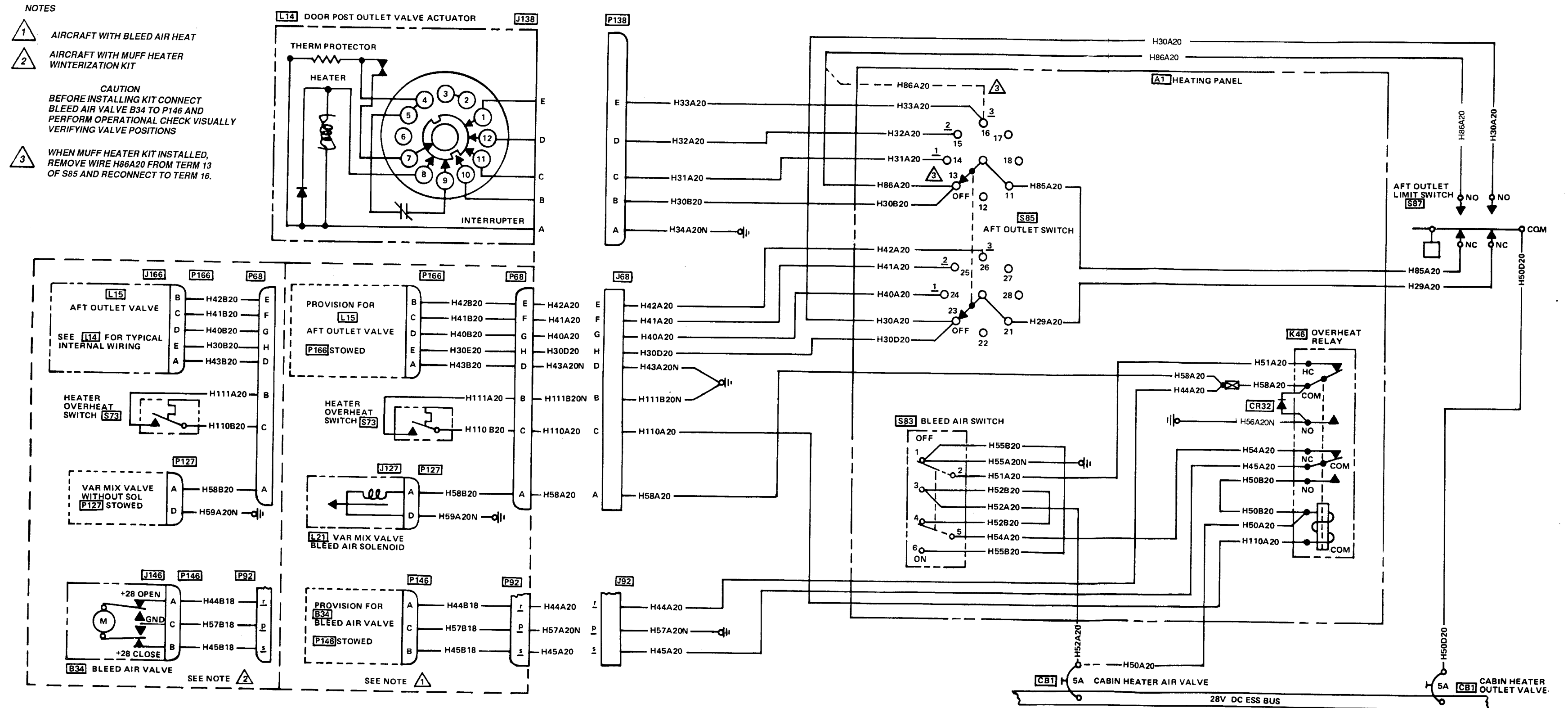


Figure 34. Cabin Heating System (Effective 65-16868 and Subsequent, Sheet 1 of 2).



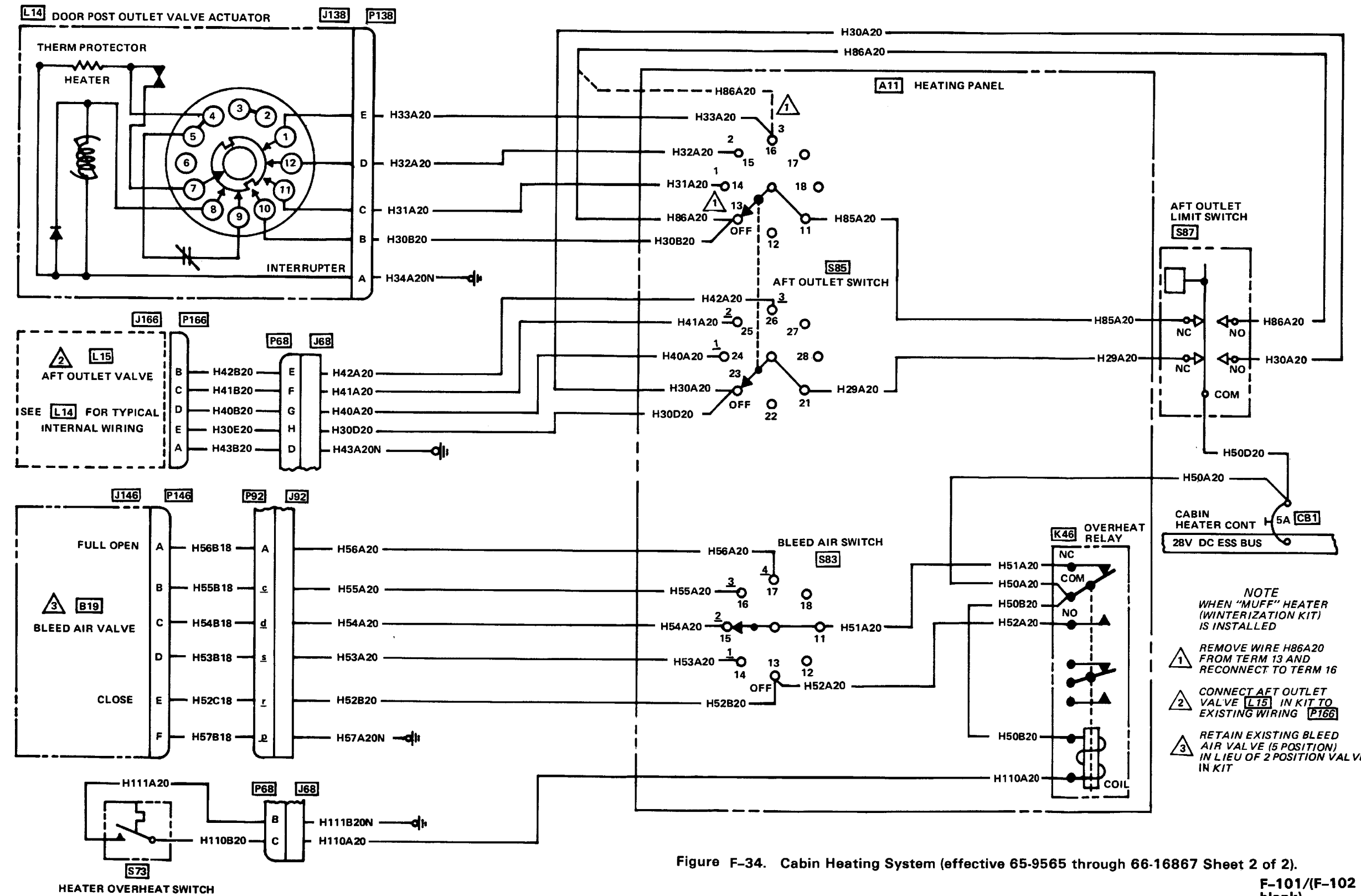
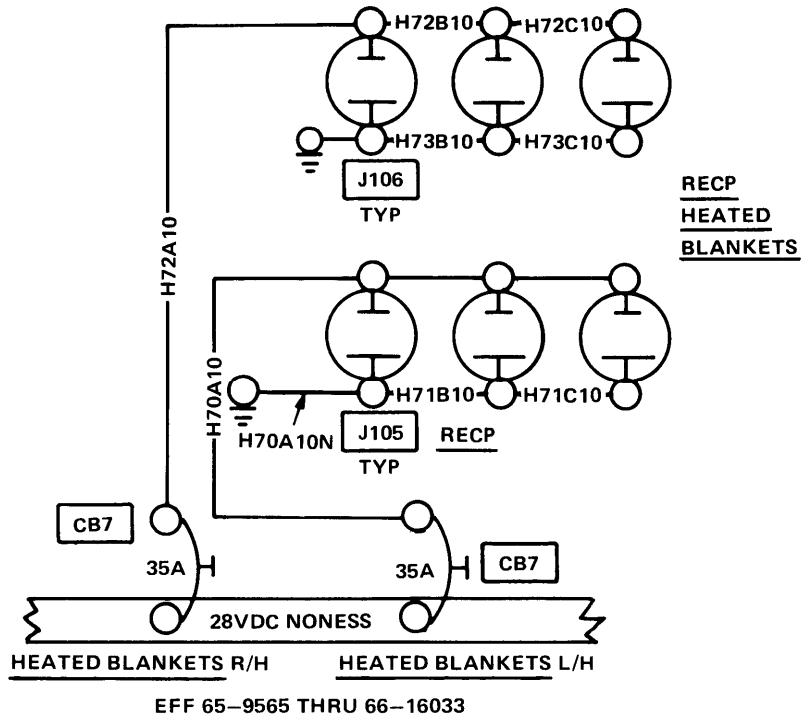


Figure F-34. Cabin Heating System (effective 65-9565 through 66-16867 Sheet 2 of 2).

F-101/(F-102 blank)





H70B10

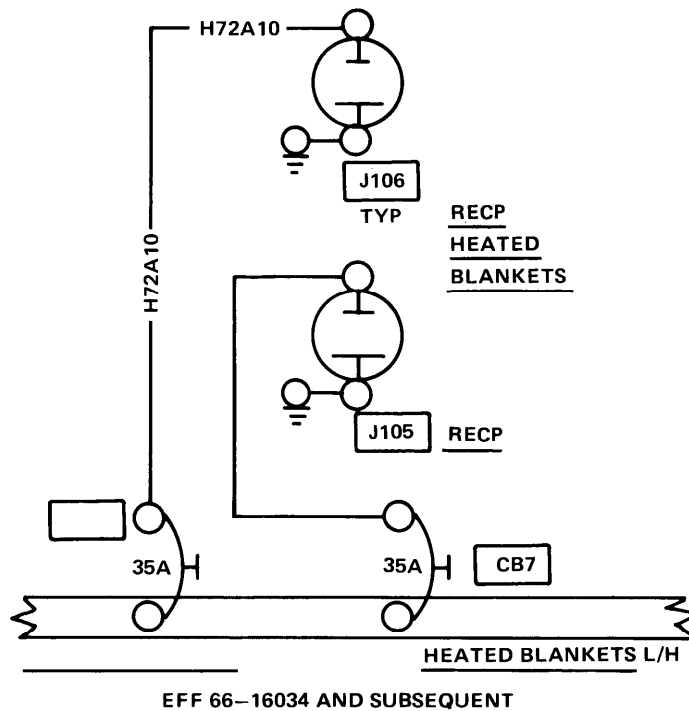
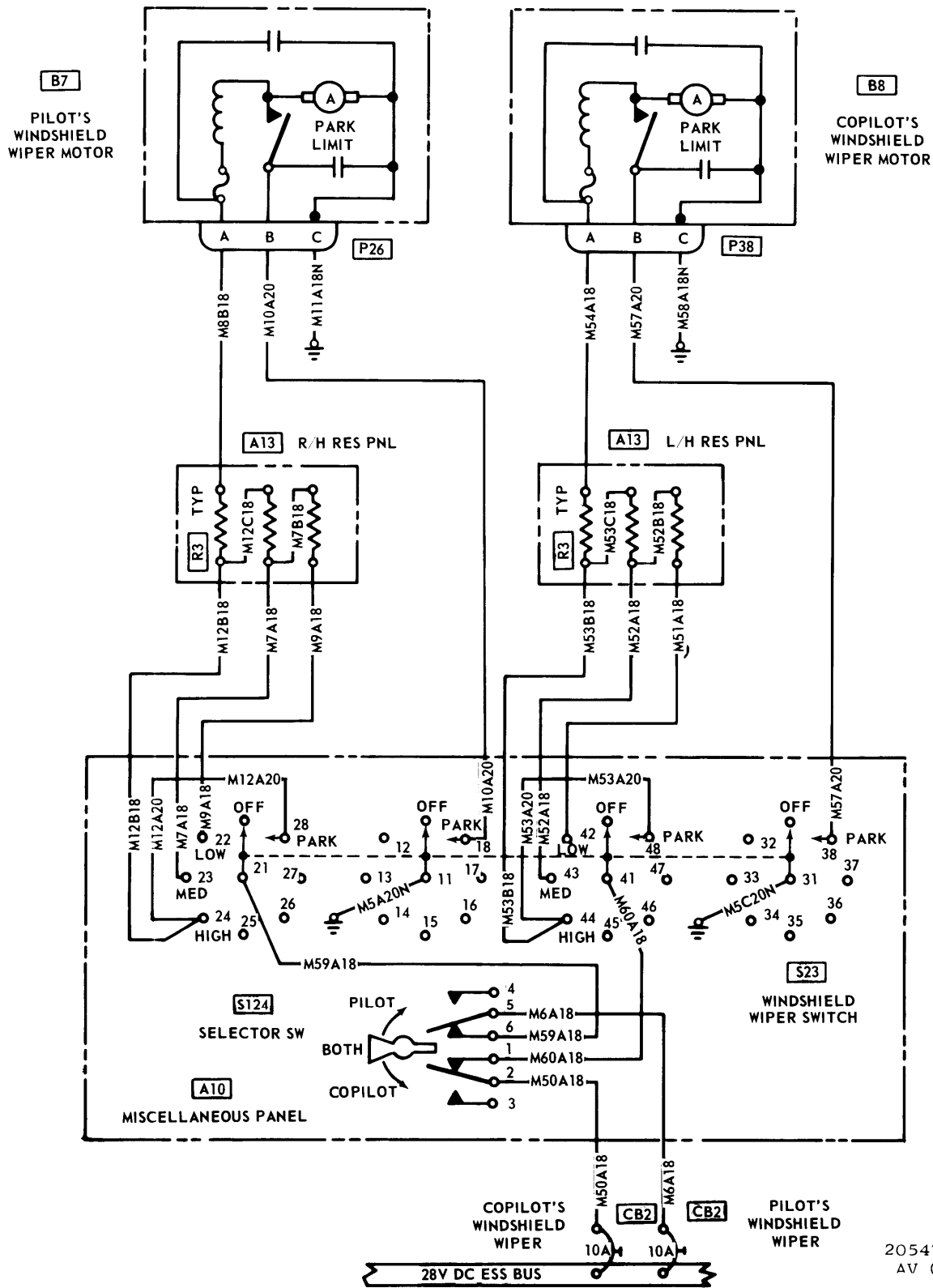
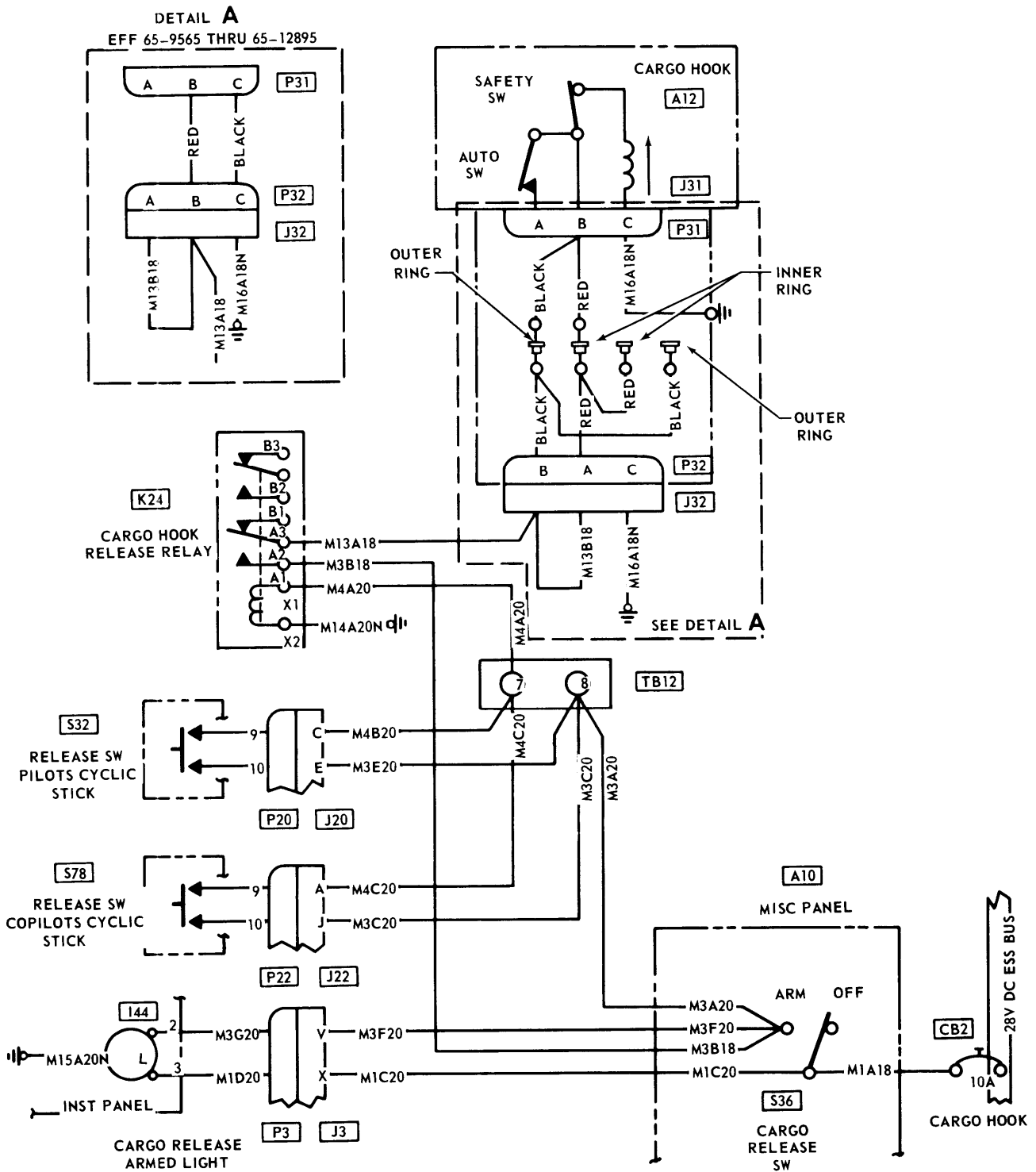


Figure F-35. Heated Blanket Receptacle System



205475-129  
AV 054277

Figure F-36. Windshield Wiper System



205475-120  
AV 054278

Figure F-37. Cargo hook system



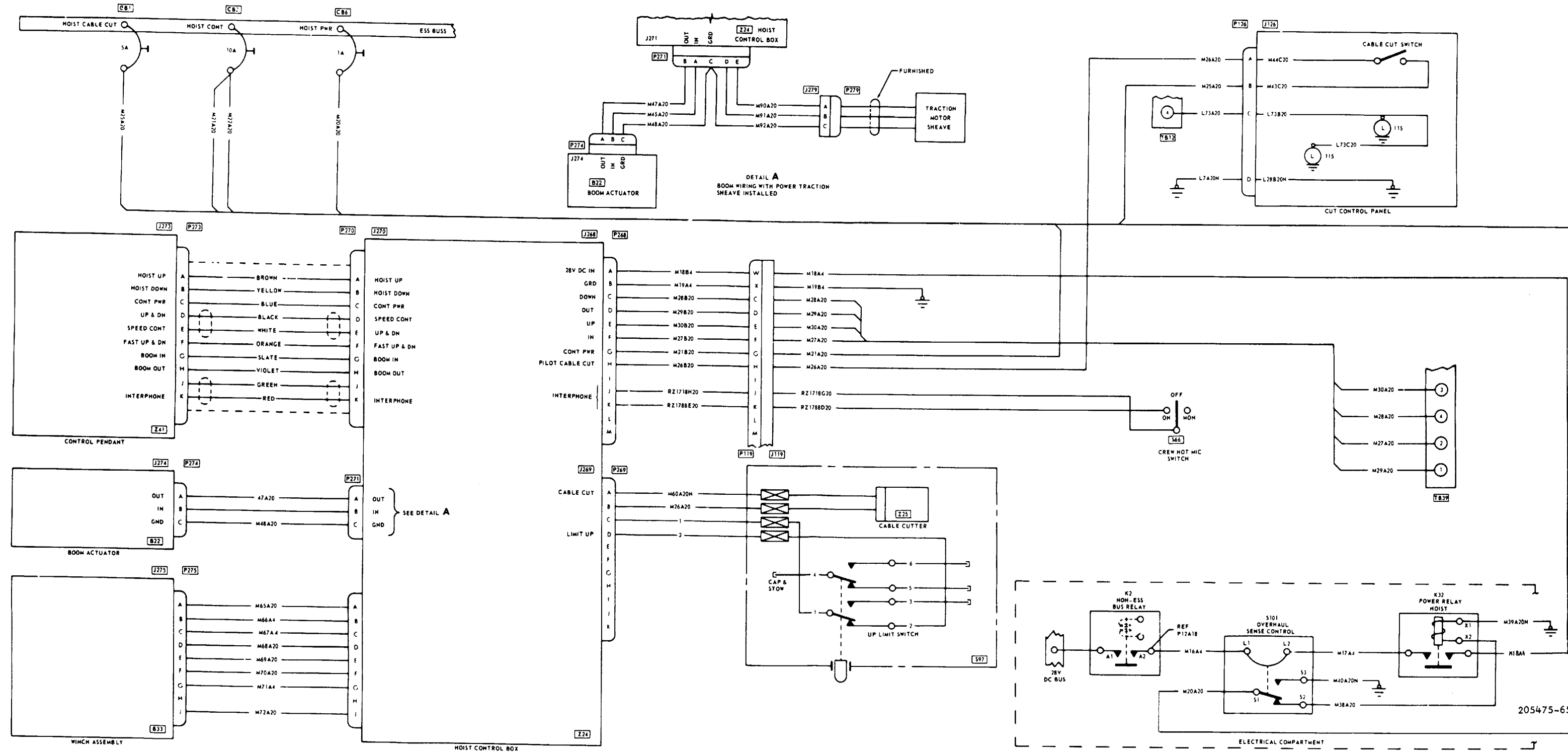
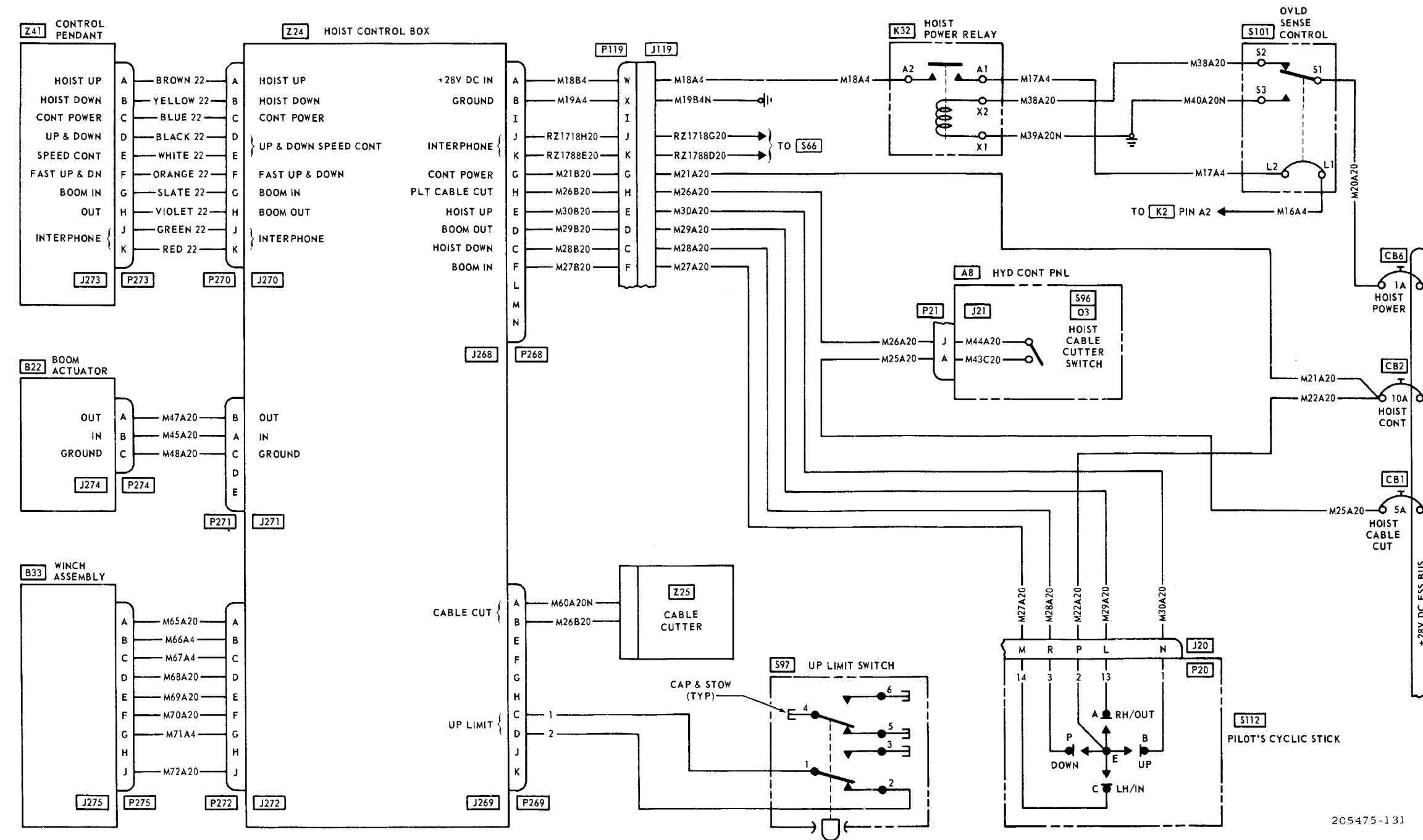


Figure F-38. Rescue hoist system (prior to 65-9565) (Sheet 1 of 2)



205475-1 31

Figure F-38. Rescue hoist system (65-9565 and subsequent) (Sheet 2 of 2)

F-109/(F-110 blank)





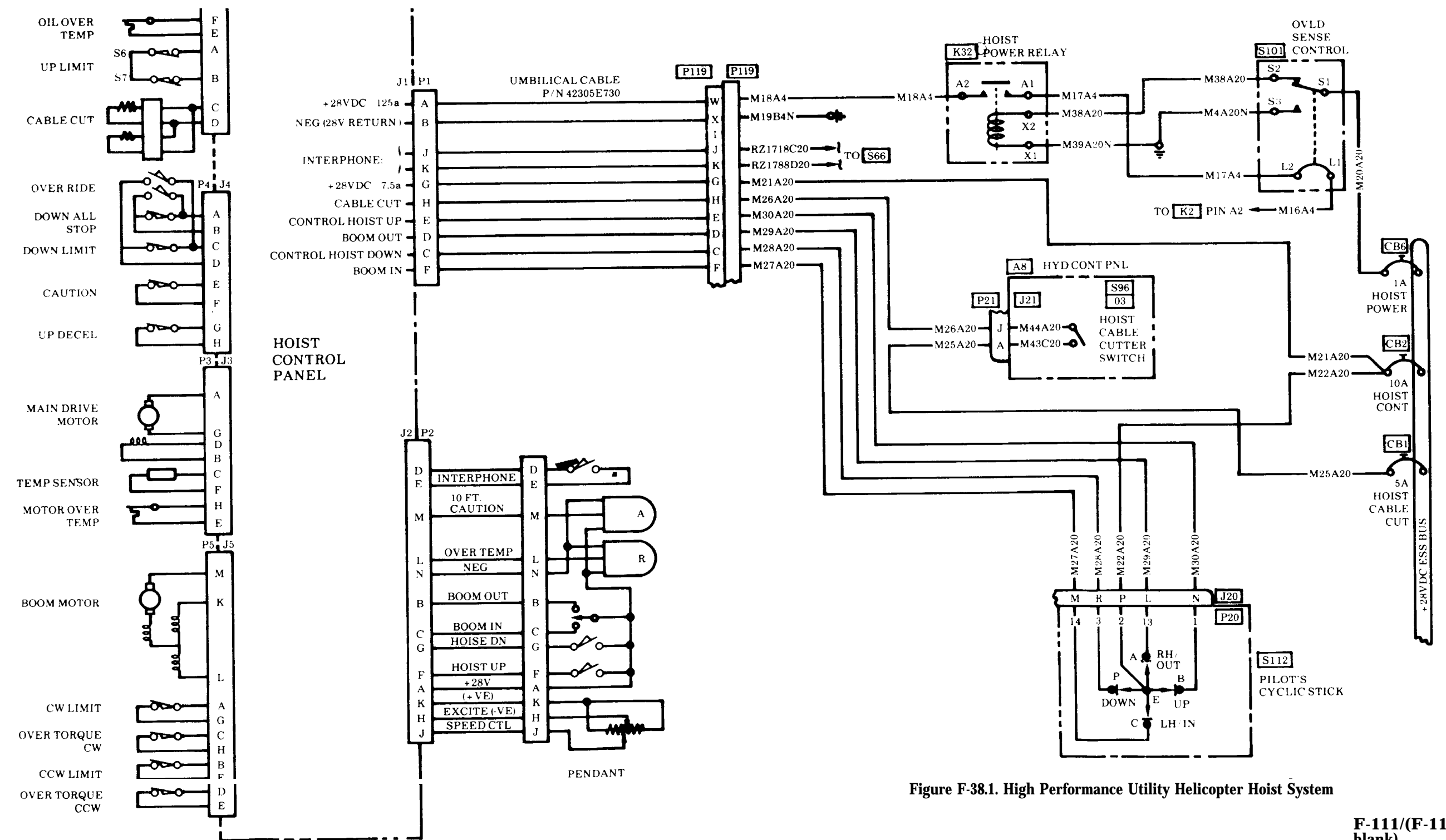
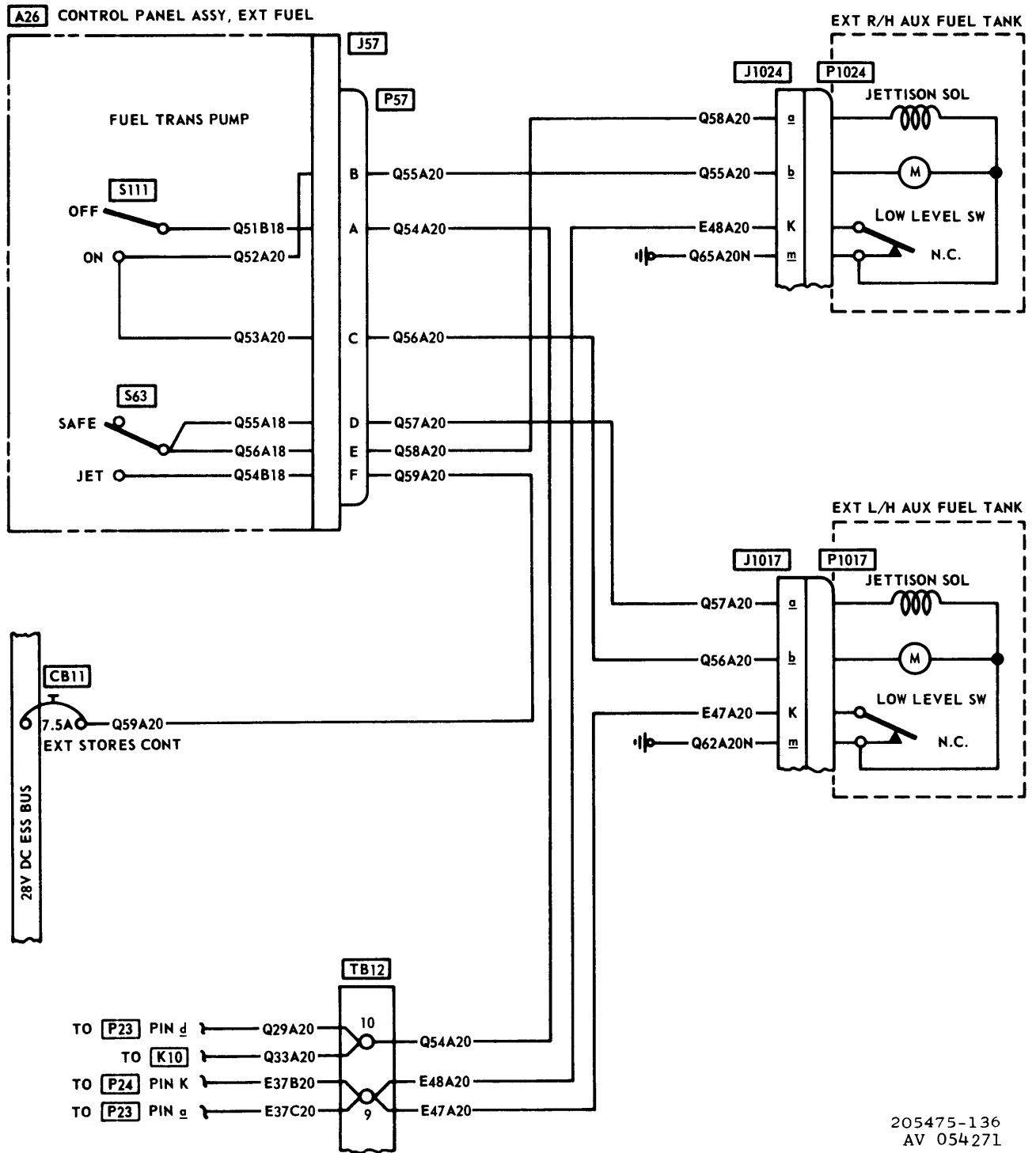


Figure F-38.1. High Performance Utility Helicopter Hoist System





205475-136  
AV 054271

Figure F-39. External fuel system

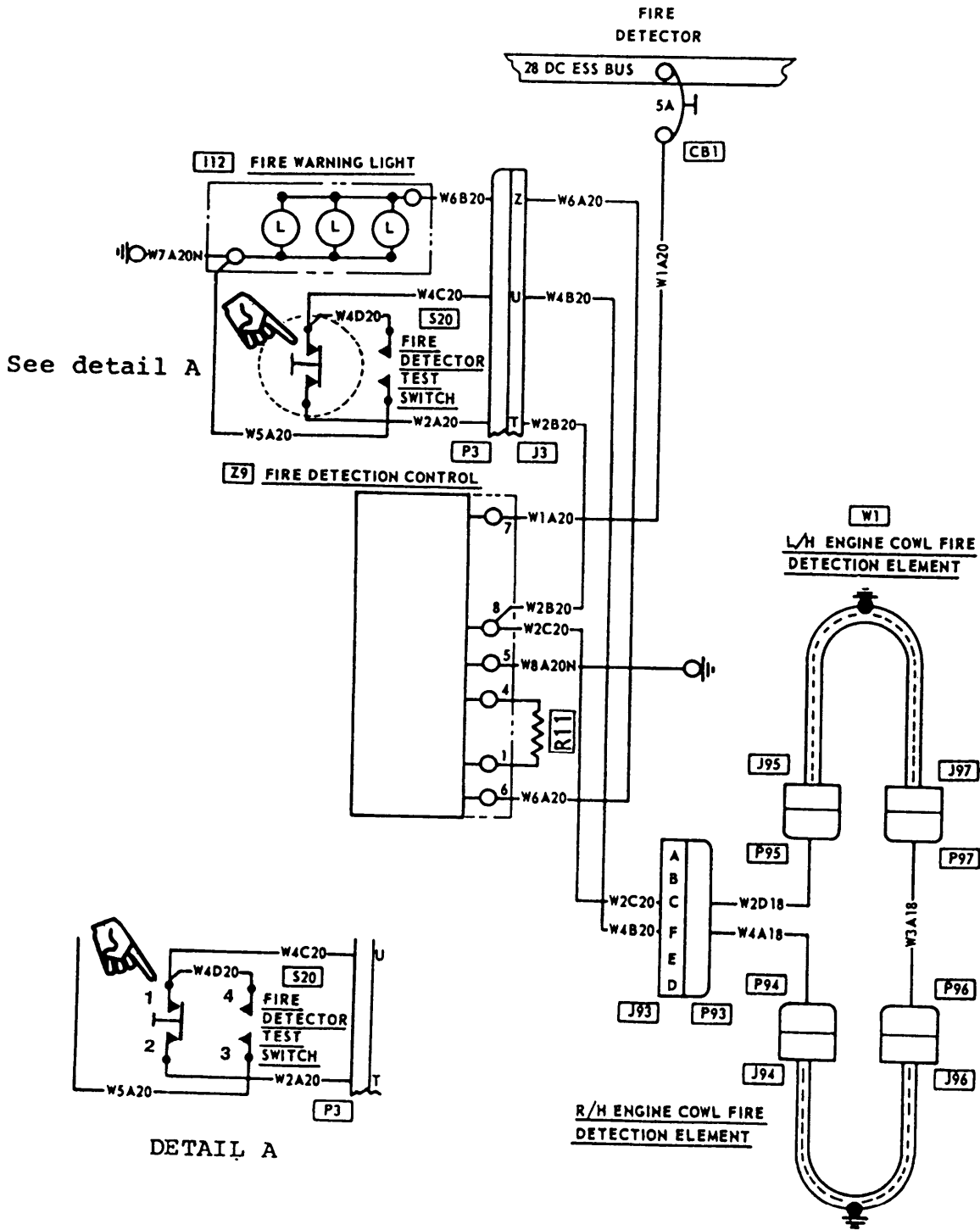


Figure 40. Fire Detector System

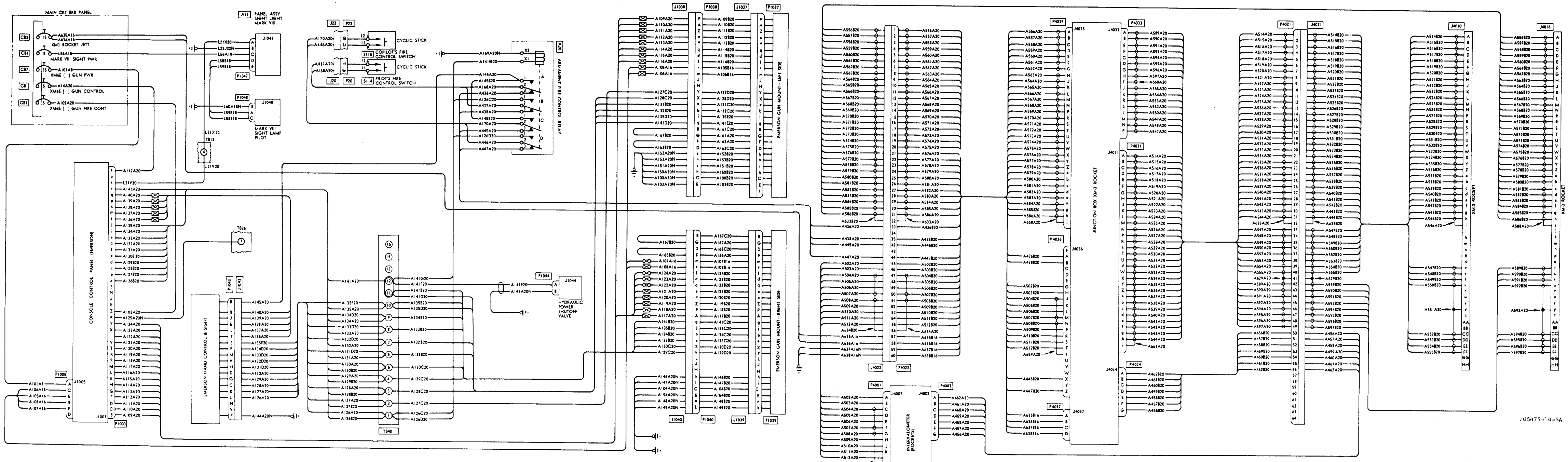


Figure F-41. Armament wiring diagram — UH-1H (63-8739 through 63-8859, and 63-12956 through 63-13002) (Sheet 1 of 3)

F-115/(F-116 blank)

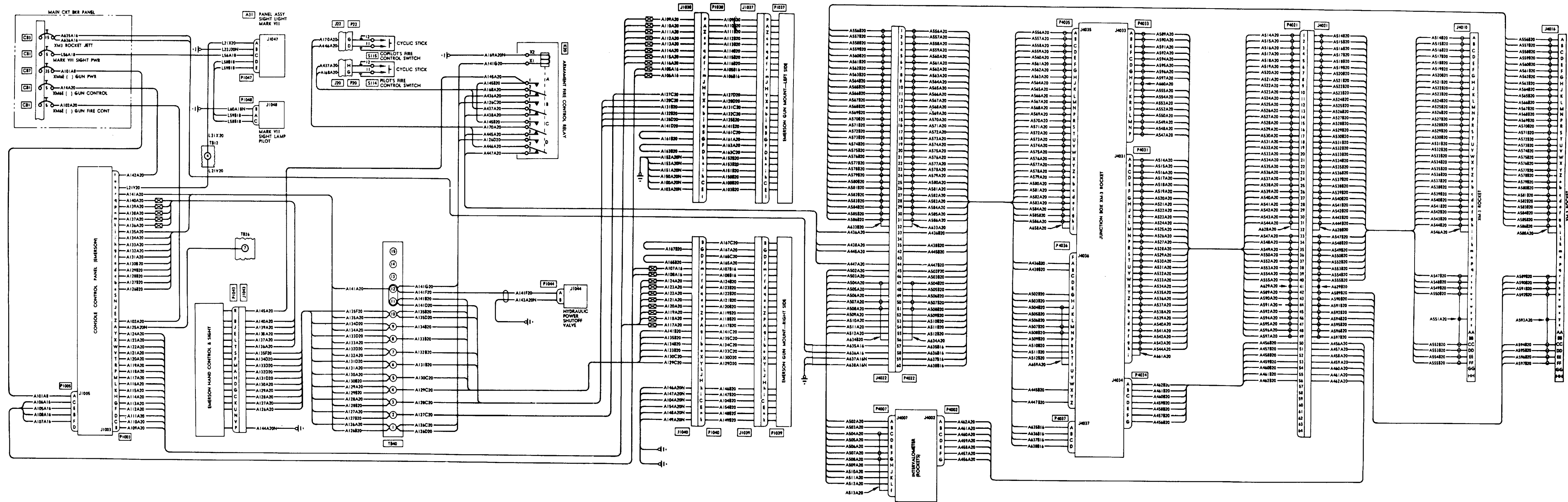


Figure F-41. Armament wiring diagram — UH-1H (64-23492 through 64-13901) (Sheet 2 of 3)

205475-2C-5A

F-117/(F-118 blank)

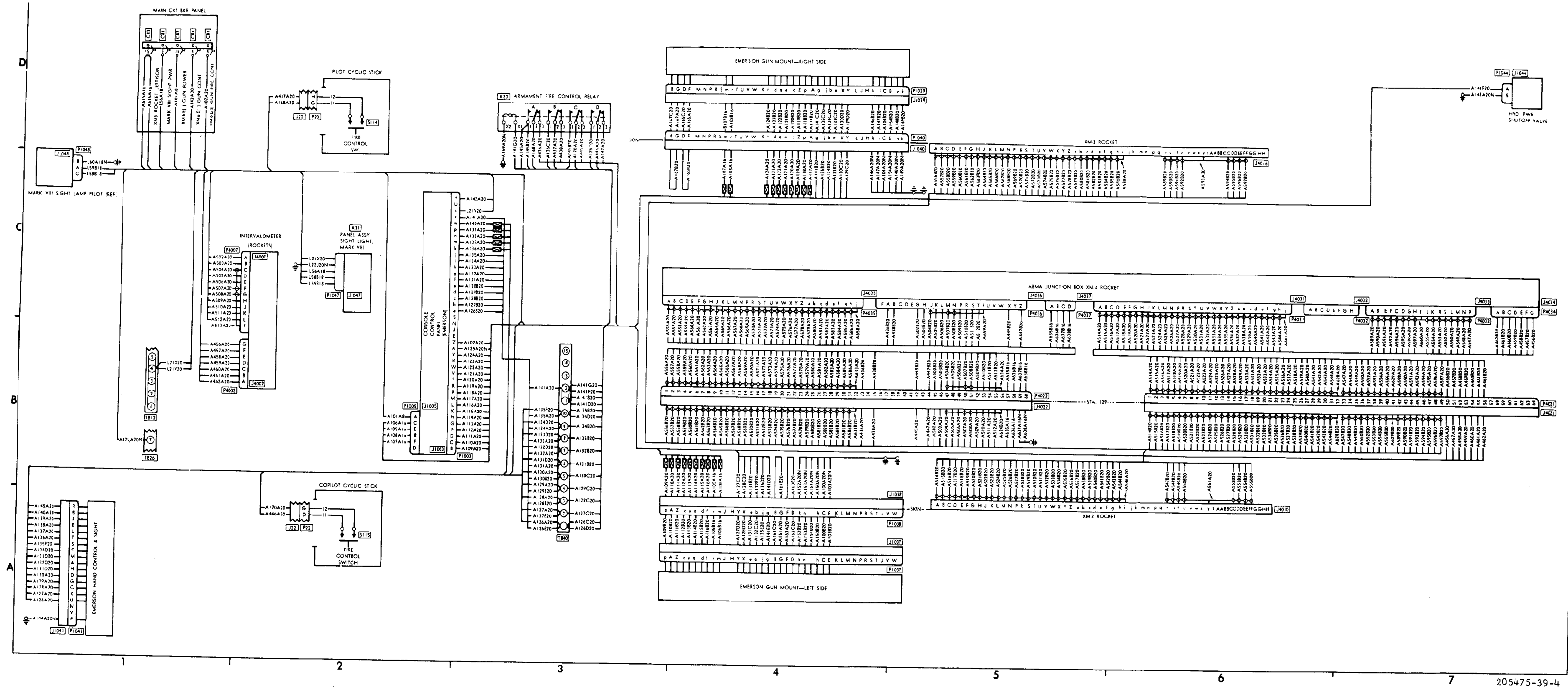


Figure F-41. Armament wiring diagram — UH-1H (65-9565 through 65-10135, 65-12773 through 65-12776, 65-12847 through 65-12852, and 65-12857 through 65-12895) (Sheet 3 of 3)

F-119/(F-120 blank)



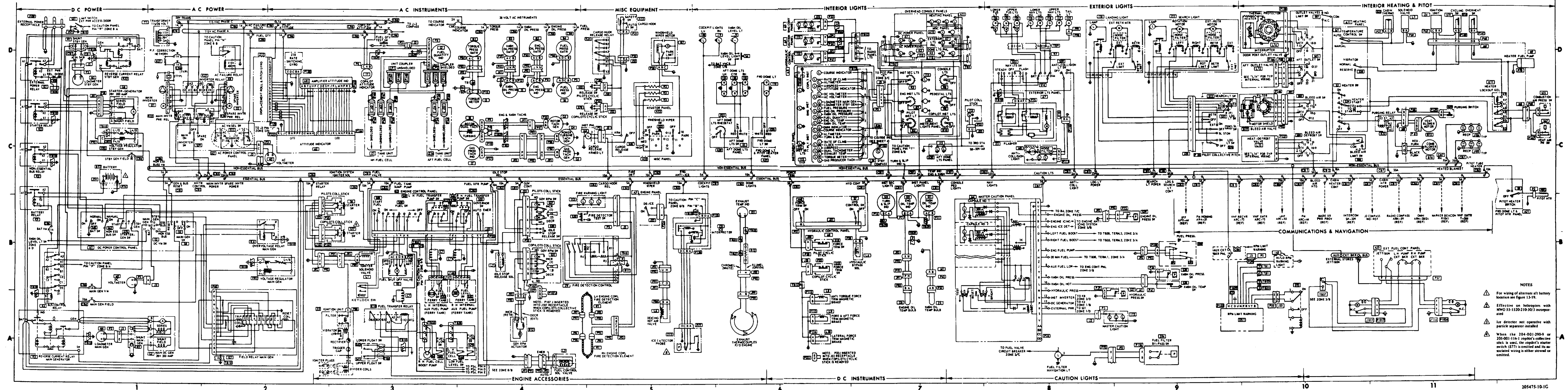


Figure F-42. Electrical schematic — UH-1H (62-2106 through 62-2113, and 62-12351 through 62-12372)

F-121/(F-122 blank)

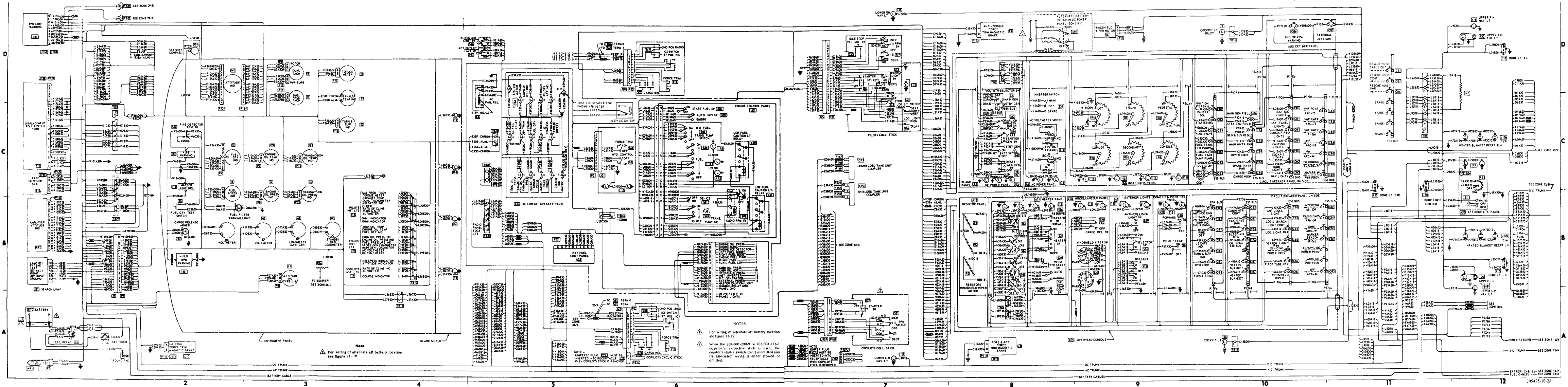


Figure F-43. Electrical wiring diagram — UH-1H (62-2106 through 62-2113, and 62-12351 through 62-12372) (Sheet 1 of 2)

F-123/F-124 blank

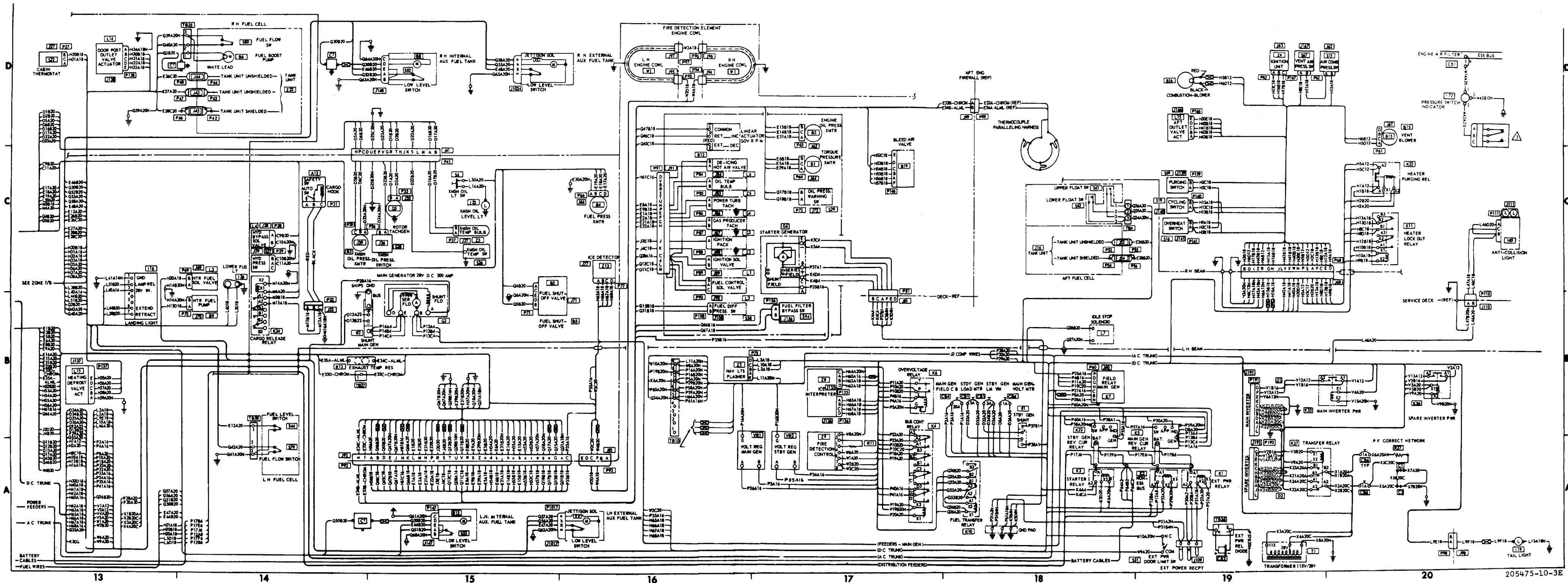


Figure F-43. Electrical wiring diagram — UH-1H (62-2106 through 62-2113, and 62-12351 through 62-12372) (Sheet 2 of 2)

F-125/(F-126 blank)

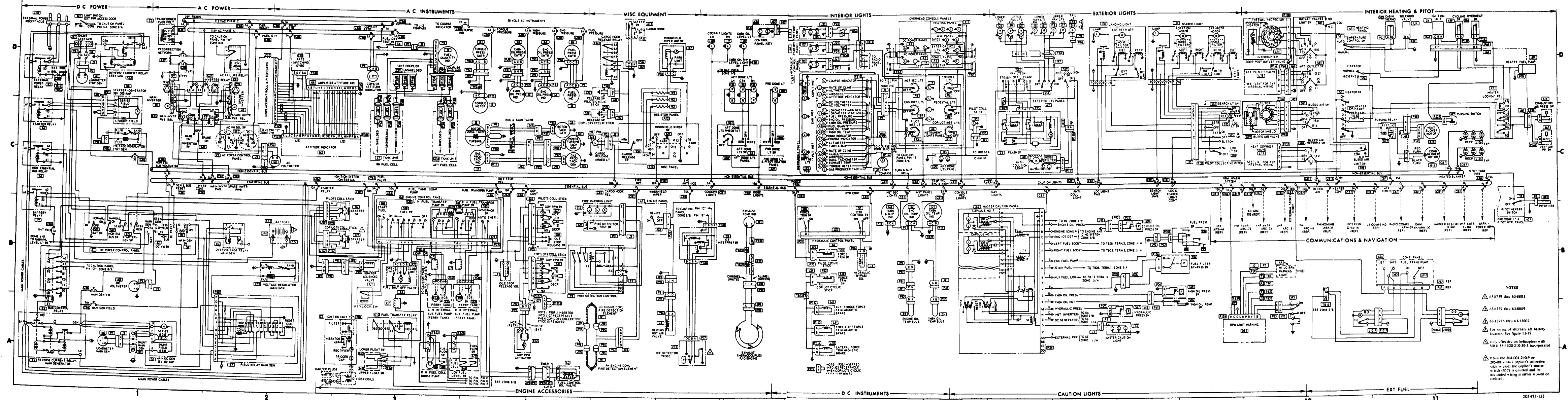


Figure F-44. Electrical schematic — UH-1H (63-8739 through 63-8859, and 63-12956 through 63-13002)

F-127/(F-128 blank)



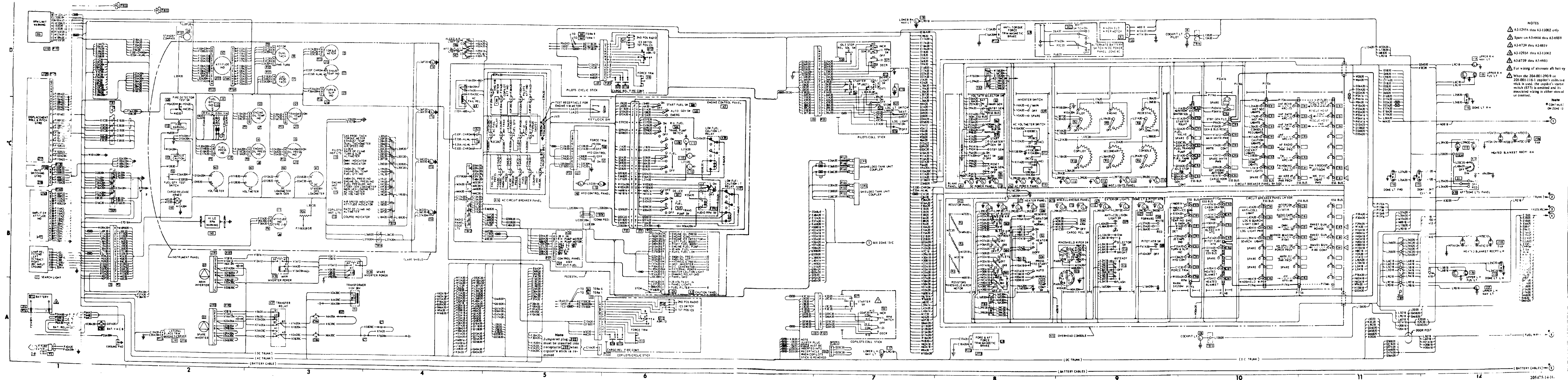


Figure F-45. Electrical wiring diagram — UH-1D (63-8739 through 63-8859, and 63-12956 through 63-13002) (Sheet 1 of 2)

F-129/(F-130 blank)

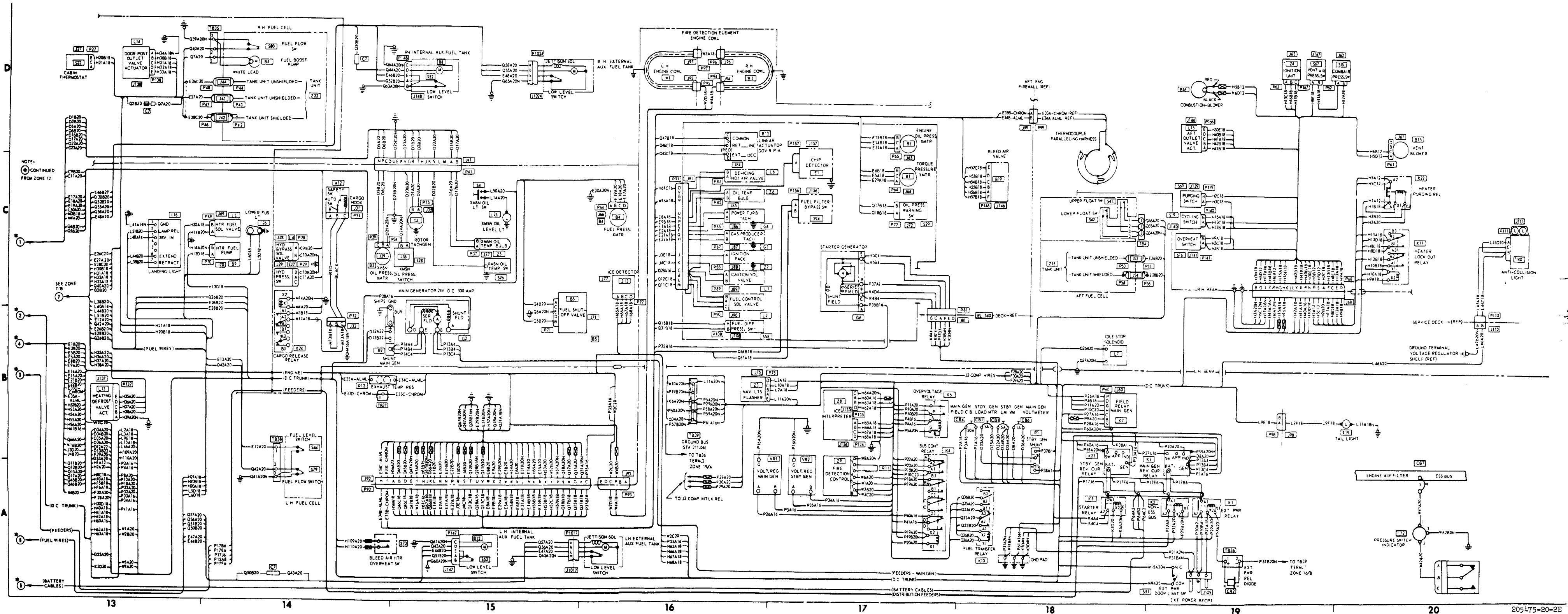


Figure F-45. Electrical wiring diagram — UH-1D (63-8739 through 63-8895, and 63-12956 through 63-13002) (Sheet 2 of 2)

F-131/(F-132 blank)



## ALPHABETICAL INDEX

	<i>Paragraph</i>		<i>Paragraph</i>
<b>A</b>			
AC Transformer.....	9-113	Alignment-Main Driveshaft P/N 205-040-004	6-24
AC Voltmeter.....	8-298	Allocation Chart-Maintenance .....	B-1
Acceptance/Rejection Criteria-Transmission		Allocation Chart--Use of the Maintenance...	B-2
Assembly-Inspection .....	6-28	Alternating Current Power Distribution	
Access & Inspection Provisions .....	F2-18	System.....	9-98
Access Covers & Doors.....	2-24	Altimeter-Barometric-Troubleshooting . . . .	T8-10
Actuator, Linear.....	4-118	AN/APR-39 (When Installed)-Radar Warning	
Adapter and Cap Assembly .....	10-77	Indicating System .....	8-314
Adapter and Plate.....	F14-20	AntiCollision Light .....	9-211
Adjustable Window-Crew Door .....	2-154	AntiCollision Light System.....	9-207
Adjuster Assembly .....	11-115	Appendix A-References.....	A-1
Adjustment Procedures (Crashworthy)-Circuit		Appendix C—Aircraft Inventory Master	
Arrangement-Adapter Cable .....	F8-7	Guide.....	C-1
Aft Center Fuel Cell Coverplate .....	10-72	Appendix D-Illustrated Field Manufacture	
Aft Landing Gear Attachment		Item List.....	D-1
Point .....	F2-24.1, F-24.4	Appendix E Intermediate Storage .....	E-12
Air Blower-Combustion Heater .....	13-57	Appendix E-Storage, Short Term .....	E-3
Air Blower-Exhaust Heater .....	13-95	Appendix E Storage of Aircraft	
Aircraft All Weather Covers .....	F1-11	Appendix E Flyable Storage .....	E-2
Aircraft Covers .....	1-45	Armament Control-Panel Assembly .....	16-89
Description .....	1-46	Armament couplings .....	7-108
Aircraft Inventory Master Guide Appendic C	C-1	Armament Junction Box.....	16-101
Aircraft Jacking and Leveling .....	1-36	Armament Subsystem 7.62MM Machine	
Aircraft Towing.....	1-34	Gun M23 .....	16-27
Air Falter Switch-Engine.....	F9-4	Armament Subsystem M23 Machine Gun	
Air Induction System.....	4-12	M60D in Stowed Position rS .....	F16-12
Air Induction System, Non-Self-Purging		Armament Subsystem-M59 .....	16-32
Particle Separator-Description .....	4-29	Armament Subsystem M59 Main Compo-	
Air Induction System Louver and Filter type	4-14	nents .....	F16-23
Air Induction System-Non-Self-Purging		Armored Crew seat.....	2-247
Particle Separator.....	4-28	Armored Crew Seat Headguard .....	F2-48
Air Inlet Filters .....	4-23	Attitude Indicating System.....	8-190
cleaning .....	4-25	Attitude Indicator-Troubleshooting.....	T8-1 1
Air Inlet Filters-Inspection.....	4-17	Attitude Indicators.....	8-192
Air Inlet Screens--Non-Self-Purging Particle		Auxiliary Exhaust Heater.....	13-84
Separator .....	4-30	Auxiliary Exhaust Heater-Heat Exchanger.	13-87
Air Intake Bellmouth, Screen and Baffles-		Auxiliary Exhaust Heater System Schematic	F13-10
Installation .....	4-22	Auxiliary Fuel Cell Fill Cap-Crashworthy..	10-171
Air Intake, Engine.....	4-20	Auxiliary Fuel Cell Fuel Gage-Crashworthy	10-167
Air Particle Separator-Self-Purging .....	4-52	Auxiliary Fuel Cell Fuel Pump .....	10-157
Air Particle Separator-Self-Purging-Air		Auxiliary Fuel Cell Pump Assembly-	
Induction System .....	4-43	Crashworthy.....	10-183
Air Particle Separator-Self-Purging-Inlet		Auxiliary Fuel Cell Refuel Receiver-	
Foreign Object Damage (FOD) Screen .....	4-46	Crashworthy.....	10-179
Air Particle Separator-Self-Purging-Air		Auxiliary Fuel Cell Shutoff Valve-Crash-	
Induction System—Description .....	4-44	worthy .....	10-181
Airpeed Indicator .....	8-172	Auxiliary Fuel Provisions.....	10-156
		Auxiliary Fuel System-Servicing .....	1-4
		Auxiliary Fuel System-300 Gallon Crash-	
		worthy .....	10-161



## ALPHABETICAL INDEX (Continued)

	<i>Paragraph</i>		<i>Paragraph</i>
<b>B</b>			
Baffle Assembly-Induction.....	2-72	Circuit Breaker-AC .....	9-91
Barometric Altimeter.....	8-181	Circuit Breaker-DC .....	9-12
B a t t e r y.....	9-30	Classification of Damage-Honeycomb Panels .....	T2-5
Battery Feeder Relay.....	9-41	Classification of Damage-Sheet Metal Skins Forward Fuselage .....	T2-6
Battery Relay .....	9-39	Cleaning .....	1-14
Battery system.....	9-26	Cleaning & Treating Corroded Parts .....	T M
Battery System-Troubleshooting .....	T9-1	Cleaning-Power Plant Assembly .....	4-4
Beam-Lift.....	2-58	clock.....	8-231
Beam-Lift-Repair .....	F2-22	Clock-Troubleshooting .....	T8-15
Bearings .....	11-185	Closed Circuit Refueling Receiver .....	10-83
Bellcranks Levers and Supports-Collective Control System.....	1147	Closed Circuit Refueling Receiver .....	10-88
Bellcranks, Levers and supports-cyclic Control System.....	11-101	Cockpit Lights .....	9-142
Bellcranks, Levers and Supports--Elevator Control System.....	11-179	Cockpit Lights-Troubleshooting .....	T9-8
Bellcranks, Levers, and Support-Tail Rotor Control System .....	11-164	Collective Control System .....	11-4
Blackout Curtains .....	2-186	Collective Jackshaft.....	11-7
Blade, Main Rotor .....	5-27	Collective Levers.....	5-68
Blade Composite Main Rotor .....	5-34.2	Collective Stick Copilots.....	11-34
Blades, Tail Rotor.....	5-114	collective Stick, Pilots .....	11-25
Blanket Receptacles-Heated .....	9-276	Compass-Standby .....	8-225
Bleed Air and Defroster.....	13-1	Compass-Standby-Troubleshooting .....	T8-14
Bleed Air Heating System.....	9-270	Composite Main Rotor Blade .....	5-34.2
Bleed Check Valve-Governor .....	10-46	cleaning .....	1-19.1, 5-34.4
Blood Bottle Hooks .....	16-105	Description .....	5-34.3
Boost Pumps-Fuel .....	10-94	Preliminary Inspection.....	5-34.5
Brake-Cyclic Controls, Magnetic .....	11-73	Repair .....	5-34.6
Breakaway Valves .....	10-155	Composite Main Rotor Blade UH-1H <b>CB</b> .....	F5-26. 1
Breaker Valve-Siphon.....	10-66	Example of When to Use Pitch Link Versus Tab.....	F5-87.2
Build-up-Universal Transmission Assembly	F6-15	Vibrex Chart for Vertical I/Rev <b>CB</b> .....	F5-87.3
Bulb-Engine Oil Temperature .....	8-90	Connector Replacement Chart .....	F-9
Bus Control Relay .....	9-83	Console-Pedestal Lights-Instrument .....	9-160
Bus Relay-Nonessential.....	9-87	Consumable Maintenance Supplies and Materials .....	1-22
<b>C</b>			
Cabin Floor Panels.....	2-28	Consumable Maintenance Supplies and Materials .....	T1-1
Cabin Roof Windows .....	2-161	Control Assembly-Collective JackShaft .....	11-17
Cabin Thermostat .....	1347	Control Panel, Mine Dispenser .....	16-38
Center Service Deck Panel Repair .....	F2-12	Control Panel-M6 Subsystem 7.62MM M60C Machine Gun .....	16-64
Check Valve.....	10-140	Control Panels .....	9-19
Check Valve-Governor Bleed .....	10-46	Control Quadrant.....	11-137
Check Valves .....	7-26	Control Relay—Bus .....	9-83
Chip Detector/Oil Contamination .....	4-101	Control Tube and Quill—Tail Rotor .....	11-143
		Control Stick, Cyclic .....	11-56
		Control System Circuitry+Governor .....	9-252
		Control System Circuitry-Hydraulic .....	9-226
		Control System, Collective .....	11-4
		Control System, Elevator .....	11-170

ALPHABETICAL INDEX (Continued)

	<i>Paragraph</i>		<i>Paragraph</i>
Control System Flight.....	11-1		
Control Tubes-Collective Control System...	11-41		
Control Tubes-Cyclic Control System . . . . .	11-41		
Control Tubes-Elevator Control System . . . . .	11-173		
Control Tubes-Tail Rotor Control System...	11-158		
Controls & Accessories-Engine . . . . .	9-242		
Controls, Tail Rotor Crosshead . . . . .	5-107		
Conversions-Decimal Equivalent . . . . .	F1-5		
Converter Assembly . . . . .	F12-7		
Troubleshooting . . . . .	T12-3		
Converter & Motor Assy-L/R Configuration	F12-7		
Cooler Assembly-Oil . . . . .	6-217		
Copilots Collective Stick.....	11-34		
Corrosion-Aluminum and Magnesium Alloy, Treatment . . . . .	1-20		
Corrosion Damage Classification-General	T2-3		
Coupling-Quick Disconnect-Inspection . . .	F6-23		
Removal . . . . .	6-151		
couplings, Armament.....	7-108		
Couplings-Inner-Spherical on Main Driveshaft-inspection Criteria . . . . .	F6-3		
Course Indicator (ID-1347( )/ARN) . . . . .	8-221		
Covers-Aircraft . . . . .	1-45		
Cowling-Engine . . . . .	2-44		
Cowling-Transmission . . . . .	2-37		
Cowling-Transmission & Engine . . . . .	F2-20		
Cowlings & Fairings.....	2-35		
Description . . . . .	2-36		
Crew Door Jettison (Ejection) Mechanism . . .	2-98		
Crew Door Jettison Mechanism . . . . .	F2-31		
crew Doors . . . . .	2-84		
Crew Doors-Latching Mechanism . . . . .	2-92		
crew Seat-Armored . . . . .	2-247, F2-47		
Crew Seat Belts . . . . .	2-241		
Crew Seat Covers . . . . .	F2-45, 2-225		
Crew Seat-standard . . . . .	2-216		
Critical Areas & Repair Limits-Windshield & Windows . . . . .	F2-41		
Cross Fitting.....	10-101		
Crosshead Controls, Tail Rotor . . . . .	5-107		
Crossover Assemblies.....	10-59		
Curtains-Blackout . . . . .	2-186		
Cyclic Control Stick . . . . .	11-56		
Cyclic Control System.....	11-53		
		<b>D</b>	
		Damage Classification-General-Corrosion	T2-3
		Damage-Classification-Honeycomb Panels . . . . .	T2-5
		Damage Limits-Intermediate Gearbox Support Installation.....	F2.62.1
		Damage Limits Repair-Lift Beam . . . . .	F2-21
		Dampers and Adapters . . . . .	5-48
		Dampers-Friction . . . . .	6-149
		DC Bus System-Generator.....	9-56
		DC Bus System-Generator-Troubleshooting (Helicopters Prior to S/N 66-746) . . . . .	T9-3
		DC Bus System-Generator-Troubleshooting (Helicopters S/N 66-746 and Subsequent..	T9-4
		DC Circuit Breakers . . . . .	9-12
		DC Generator-Main.....	9-60
		DC Voltmeter.....	8-300
		Debris Monitor . . . . .	6-49.1
		Decimal Equivalent Conversions . . . . .	F1-5
		Defroster Installation-Bleed Air . . . . .	13-1
		Defroster Installation-Combustion Heater and.....	13-14
		De-ice Circuitry-Engine . . . . .	9-244
		Dimensions-Helicopters . . . . .	F1-7
		Direct Current Power Distribution System . . .	9-1
		Dome Lights . . . . .	9-151
		Doors-Access Covers . . . . .	2-24
		cargo . . . . .	2-114
		crew . . . . .	F2-28
		Nose.....	2-77
		Drain Valve-Cell.....	10-26
		Drive Quill-Tail Rotor.....	6-125
		Driveshaft Assembly-Main-Limits Chart P/N 205-040-004 . . . . .	F6-10
		Driveshaft Hangers.....	6-167
		Aft Tailboom Installation . . . . .	F6-50
		Coupling Teeth Wear Patterns . . . . .	F6-46
		Forward Tailboom Installation . . . . .	F6-49
		Fuselage Installation . . . . .	F6-48
		Hanger.....	F6-45
		Driveshaft-Main P/N SKCP2281-1 . . . . .	6-24.1
		Driveshaft-Main P/N 204-040-004 . . . . .	6-13
		Driveshaft Main-Alignment P/N 205-040-004 . . . . .	6-24
		Driveshaft-Main-Assembly and Installation P/N 205-040-004 . . . . .	F6-9
		Driveshaft-Main Disassembly P/N 205-040-004 . . . . .	6-18

## ALPHABETICAL INDEX (Continued)

	<i>Paragraph</i>		<i>Paragraph</i>
Driveshaft-Main-Cleaning P/N 205-040-004 .....	6-19	Engine Oil Contamination Troubleshooting..	4-106.9
Driveshaft-Main-Inspection P/N 205440-004 .....	6-20	Engine Oil Pressure Indicator .....	8-60
Driveshaft-Main-Inspection of Installed P/N 205-040-004.....	6-15	Engine Oil Pressure Transmitter .....	8-69
Driveshaft Main-Installation P/N 205440-004 .....	6-23	Engine Oil System-servicing .....	1-5
Driveshaft Main P/N 205-040-004-Lubri cation and Assembly .....	6-22	Engine Oil Tank.....	4-84
Driveshaft-Main-Removal P/N 205-00004 .....	6-17	Engine Oil Temperature Bulb .....	8-90
Driveshaft Main P/N 205-040-004 .....	6-21	Engine Oil Temperature Indicator .....	8-80
Driveshaft-Main-Troubleshooting P/N 205—00004.....	T6-2, 6-16	Engine Quick Change Assembly .....	4-133
Driveshaft-Tail Rotor.....	6-159	Engine Vibration Meter Receptacle .....	9-120
Droop Compensator Controls .....	4-126	Equipment Lists.....	F-7
Dual Tachometer.....	8-14	Equipment Location-Electrical .....	F9-2
Dual Tachometer-Troubleshooting .....	T8-1	Example of When to Use Pitch Link Versus Tab <b>CB</b> .....	F5-87.2
Ducts, Nozzles, Registers, Gaskets and Miscellaneous Valves.....	13-4	Example of When to Use Tab Alone <b>CB</b> .....	F5-87.3
<b>E</b>			
EGT Indicator Scale &Friction Error Tol- erances Plus or Minus °Celsius .....	T8-6	Exhaust Gas Temperature Indicating System	8-99
Electrical-Component Location .....	F9-1	Exhaust Gas Temperature Indicator .....	8-101
Electrical Components (AC)-Common .....	9-91	Exhaust Heater-Air Blower .....	13-95
Description .....	9-92	Exhaust Heater-Auxiliary .....	13-84
Electrical Components (DC)-Common .....	9-3	Exhaust System .....	4-58
Electrical Components-Miscellaneous .....	9-5	Exhaust System-Clamp .....	4-60
Electrical Equipment Location .....	F9-2	Exhaust System-Tailpipe .....	4-67
Elevator Assembly.....	2-286	Exterior-Cleaning .....	1-17
Elevator, Bearing Limits.....	F2-55	Exterior-Lights System.....	9-194
Elevator Control Assy-Removal and In- stallation .....	F2-54	External Oil Filter, Eng (ODDS) .....	4-106.13
Elevator Control System.....	11-170	External Oil Filter, Xmsn .....	F6-57, 6-204
Elevator Support & Horn Assy-Wear & Damage Limits.....	F2-56	External Oil Filter.....	F6-57, 6-204
Emergency Jettison Release Mechanism .....	16-8	External Power—Application .....	1-53
Engine Assembly .....	4-6	External Power Receptacle .....	9-47
Engine Controls & Accessories .....	9-242	External Power Relay.....	9-54
Engine Cowling .....	2-44	External Power System .....	9-43
Engine Cowling-Transmission .....	F2-20	External Power System-Troubleshooting .....	T9-2
Engine De-Ice Circuitry .....	9-244	External Stores Support.....	16-1
Engine De-Ice Circuitry-Troubleshooting...	T9-15	External Stores Support Assembly .....	F16-1
Engine Instruments .....	8-10	Extinguisher and Bracket, Fire .....	17-7
Engine Mounts.....	F2-50, 2-267	<b>F</b>	
		Fairing-Tailpipe .....	2-51
		Feeder Relay-Battery .....	9-41
		Field Relay-Generator .....	9-79
		Fifth Mount Support-Pylon .....	2-62
		Fire Detection System-Engine .....	12-1
		Fire Extinguisher Bracket .....	17-7
		Firewall and Tailpipe Assembly Installation..	4-143
		Firewalls & Heat Shield .....	2-66
		First Aid Kits .....	17-1
		Fittings & Screens, Lines, Manifolds .....	6-81
		Fitting-Support Tail Rotor Driveshaft .....	6-174

ALPHABETICAL INDEX (Continued)

Paragraph	Paragraph
Flasher-Navigation Lights.....	9-229
Flight Control System.....	11-1
Flight Control System (Electrical).....	9-260
Description.....	8-162
■ Flight Safety Critical Aircraft Parts.....	1-67
Floor Panels - Cabin.....	2-28
Fluid Connectors - Torque Values.....	T1-5
Flyable Storage Appendix E.....	E-4
Force Gradient Cyclic Controls.....	11-80
Force Gradient -- Tail Rotor Controls.....	11-113
Force Trim System Circuitry.....	9-262
Forward Door Window -Crew Door.....	2-147
Forward Towing.....	1-35
Free Air Temperature Gage.....	8-305
Friction Dampers.....	6-149
Friction Damper Mount.....	F2-23.3
Friction Damper Retaining Clip.....	F2-23.1
Fuel Boost Pump Cross Fitting.....	10-107
Fuel Boost Pumps.....	10-100
Fuel Boost Pump, Cartridge.....	10-105.1
Fuel Cap and Adapter Assembly.....	10-78
Fuel Cell Coverplate -Aft Center.....	10-72
Fuel Cells -- Crashworthy.....	10-1
Fuel Cell Drain Valve.....	10-27
Fuel Cell Sump Assembly.....	10-135
Fuel Check Valve.....	10-150
Fuel Crossover Assemblies.....	1060
Fuel Ejector Pump.....	10-116
Fuel Filter Assembly.....	10-20
Fuel Flapper Valve.....	10-122
Fuel Flapper Valve Plates.....	10-128
Fuel Flow Switch.....	10-145
Fuel Governor Bleed Check Valve.....	10-47
Fuel Manifold Assembly.....	10-54
Fuel Motor Driven Shutoff Valve.....	10-40
Fuel Pressure Differential Transmitter.....	4-147
Fuel Pressure Transmitter.....	10-33
Fuel Quantity Transmitters.....	10-112
Fuel Siphon Breaker Valve.....	10-66
Fuel Warning System 20 Minute Float Switch.....	10-93
Fuel Boost & Fuel Valve Circuitry.....	9-248
Fuel Pressure Indicating System.....	8-121
Fuel Pressure Indicator.....	8-128
Fuel Quantity Indicating System.....	8-241
Fuel Quantity Indicator.....	8-248
Fuel Quantity Indicator - Troubleshooting ..	T8-16
Fuel Quantity Transmitters.....	8-252
Fuel Solenoid Valve - Start.....	9-136
Fuel Train - Heater.....	13-36
Fuel Valve & Fuel Boost Circuitry.....	9-248
Functional Check Low Fuel Caution System.....	10-19.1
Fuselage.....	2-1
Fuselage Skin - Forward.....	F2-4
Fuselage Structure.....	2-3
<b>G</b>	
Gages - Oil Level Sight.....	6-75
Gas Producer Tachometer Generator.....	8-49
Gas Producer Tachometer Indicator.....	8-40
Repair or Replacement.....	8-46
Gas Producer NI Tachometer Generator Installation.....	4-151
Gas Temperature Indicating System - Exhaust.....	8-99
Gas Temperature Indicator - Exhaust.....	8-101
Gaskets and Miscellaneous Valves - Ducts, Nozzles, Registers.....	13-4
Gearbox - Intermediate (42 Degree).....	F6-51,6-179
Gearbox - Tail Rotor.....	F6-52,6-190
Gearboxes -- Intermediate (42 Degree) and Tail Rotor (90 Degree) - Servicing.....	1-8
Gearboxes -- Transmission Assy, Identification of Metal Particles (Without ODDS).....	F6-14,6-30
Gearboxes - Transmisson Assy, Decision Criteria for Replacement (Without ODDS).....	F6-14.2,6-30.1
Generator & DC Bus System.....	9-56
Generator & DC Bus System (Helicopters Prior to S/N 66-7460) - Troubleshooting.....	T9-3
Generator & DC Bus System - (Helicopters S/N 66-746 and Subsequent) - Troubleshooting.....	T9-4
Generator Drive Quill.....	6-109
Generator Field Relay.....	9-79
Generator - Main DC.....	9-60
Generator - Power Turbine Tachometer....	8-22
Generator - Rotor Tachometer.....	8-31
Generator Shunt.....	9-69
Generator - Standby (Starter Generator).....	F9-2.1,967
Generator - Starter.....	9-126
Governor Bleed Check Valve.....	10-46
Governor Control System Circuitry.....	9-252
Governor Control System Circuitry - Troubleshooting.....	T9-16
Ground Handling.....	1-32
Ground Handling Wheel Pump - Servicing.....	1-10
Ground Handling Wheel Tires - Servicing..	1-11
Ground Test Conditions.....	7-33
Gun Firing Relay M6 Subsystem.....	16-72

## ALPHABETICAL INDEX (Continued)

*Paragraph*

*Paragraph*

H

Hangers-Driveshaft .....	61-67	Icing System Test Box Schematic .....	F9-3
Heat Exchanger-Auxiliary Exhaust Heater	13-9	(ID-1347( )/ARN) - Course Indicator .....	8-221
Heat Shield- Firewalls .....	2-66	(ID-998( )/ASN & ID-250( )/ARN-Radio	
Heat Suppressor .....	F2-51, 2-273	Magnetic Indicators .....	8-223
Heater .....	13-9	<b>Identification of Metal Particles - Trans-</b>	
Heated Blanket Receptacles .....	9-276	mission Assembly & Gearboxes .....	P6-14, 6-30
Heater Air Pressure Switches .....	13-52	Idle Stop System Circuitry .....	9-256
Heater Fuel Train .....	13-36	<b>Ignition System</b> .....	9-130
Heating System Circuitry - Bleed Air., .....	9-270	<b>Ignition Unit</b> .....	9-134
Heater System Circuitry - Muff .....	9-273	<b>Ignition Unit and Igniter Plug-Combustion</b>	
Helicopter Assembly .....	F2-1	Heater .....	13-27
Helicopter Assembly (EH-IH) .....	F2-1.1	<b>Igniter Plug-Combustion Heater Ignition</b>	
Helicopter Dimensions .....	F1-7	Unit .....	13-27
Hinged Panel .....	2-104	<b>Indicating System (AN/APR-39 (When</b>	
Hinged Panel Assy .....	F2-32	Installed)-Radar Warning .....	8-314
Hoisting .....	1-47	Indicating System-Attitude .....	8-190
Hoisting-Component .....	1-50	<b>Indicating System-Engine Oil Temperature</b>	8-78
Hoist Rescue .....	14-1	<b>Indicating System-Exhaust Gas Temperature</b>	8-99
<b>Hoist System Circuitry - Rescue (Provisions)</b>	9-286	Indicating System-Fuel Pressure .....	8-121
Honeycomb Panels .....	2-15	Indicating System-Fuel Quantity .....	8-241
Classification of Damage .....	2-17	Indicating System-Torque Pressure .....	8-141
<b>Honeycomb Panels - Classification of</b>		<b>Indicating System-Transmission Oil</b>	
Damage .....	T2-5	Pressure .....	8-258
<b>Honeycomb Panels - Minor Damage Repairs</b>	F2-7	<b>Indicating System-Transmission Oil</b>	
<b>Honeycomb Panels - Repair of Dents,</b>		Temperature .....	8-278
Scars & Scratches .....	F2-6	Indicating Systems-Tachometer .....	8-12
Hook System Circuitry - Cargo .....	9-283	Indicator-Airspeed .....	8-172
Hoses, Oil Lines and Fittings .....	4-77	Indicator-Airspeed-Troubleshooting .....	T8-9
Hoses, Tubing, Attaching Hardware .....	7-114	Indicator-Engine Oil Temperature .....	8-80
Hub and Blade Assembly, Main Rotor .....	5-3	Indicator-Exhaust Gas Temperature .....	8-101
Hydraulic Control 1 System Circuitry .....	9-266	Indicator-Fuel Pressure .....	8-123
Hydraulic Cylinder and Support Tail Rotor	11-63.1	Indicator-Fuel Quantity .....	8-243
Hydraulic Filter Assembly .....	7-46	Indicator-Gas Producer Tachometer .....	8-40
Hydraulic Pump .....	7-19	Indicator (ID- 1347( )/ARN)-Course .....	8-221
Hydraulic Pump & Tachometer Drive Quill	6-118	indicator Torque Pressure .....	8-143
Hydraulic Reservoir .....	7-9	indicator-Transmission Oil Pressure .....	8-260
Hydraulic Reservoir - Servicing .....	1-9	indicator-Transmission Oil .....	8-280
Hydraulic Servo Cylinder Assembly (Col-		Indicator-Turn & Slip .....	8-201
lective Control) .....	7-80	Indicator-Vertical Velocity .....	8-210
<b>Hydraulic Servo Cylinder Assembly</b>		indicators-Attitude .....	8-192
(Cyclic Control) .....	7-67	induction Baffle Assembly .....	2-72
Hydraulic System .....	F7-1 ,7-1	<b>inertia Reel-Shoulder Harness-Crew</b>	
		Standard Seat .....	2-231
		<b>Infrared Suppressor-Duct Assembly</b>	
		Outer Jacket .....	2-279.1

## ALPHABETICAL INDEX (Continued)

	<i>Paragraph</i>		<i>Paragraph</i>
Inlet Foreign Object Damage (POD)		Inverter Power Relay—Main . . . . .	9-105
Screen-Air Particle Separator-Self-Purging . . . . .	<b>4-46</b>	Inverter Power Relay Spare . . . . .	9-107
Inspection . . . . .	4-49	Inverter Relay . . . . .	9-109
Installation . . . . .	4-51	Inverter System . . . . .	9-93
Removal . . . . .	4-47	Inverter System—Troubleshooting . . . . .	T9-5
Repair . . . . .	4-50	Inventory Items List Component Diagram . . . . .	FC-1
Inlet Screen-Non-Self-Purging Air Particle Separator . . . . .		Irreversible Valve . . . . .	7-92
Cleaning . . . . .	4-34	Isolation of Circuits for Alignment-RPM Limit Warning Detector Models . . . . .	T9-9
Inspection . . . . .	4-32		
Installation . . . . .	4-36	<b>J</b>	
Removal . . . . .	4-33	Jack Fittings . . . . .	2-198
Repair . . . . .	4-35	Jacking and Leveling . . . . .	1-86
Input Drive Quill P/N 205-040-263 . . . . .	F6-26, 6-101	Jackshaft Collective . . . . .	11-7
Input Drive Quill P/N 204-040-363 . . . . .	F6-24, 6-92	Jettison (Ejection) Mechanism-Crew Door . . . . .	2-98
Input Drive Quills . . . . .	6-90	Jettison Release Mechanism-Emergency . . . . .	16-8
Input Driveshaft P/N 205-040-004-Lubrication and Assembly . . . . .	F6-11	Junction Box, Armament . . . . .	16-101
Inspection-Acceptance/Rejection Criteria-Transmission Assembly . . . . .	6-28		
inspection—Main Drive Shaft P/N 205-040-004 . . . . .	6-20	<b>K</b>	
Inspection of Installed Main Driveshaft P/N 205-040-004 . . . . .	6-15	Kits, First Aid . . . . .	17-1
Inspection, Preliminary Composite Main Rotor Blade- <b>CB</b> . . . . .	5-34.5		
Inspection of Roller Chain (Chain Removed) . . . . .		<b>L</b>	
Inspection-Special . . . . .	1-58	Landing and Searchlight System . . . . .	9-197
Inspection-Transmission Assembly . . . . .	6-33	Landing and Searchlights . . . . .	9-200
Inspection-Transmission Oil Filter . . . . .	6-45	Landing Gear Assembly . . . . .	3-1
Installation—Main Driveshaft P/N 205-040-004 . . . . .	6-23	Landing Gear Crosstubes . . . . .	3-8
Installation-Transmission Assembly . . . . .	<b>6-40</b>	Latch-Cargo Door . . . . .	2-122
Installation-Transmission Oil Filter . . . . .	6-49	Latch-Typical-Cargo Door . . . . .	F2-35
Instrument Console, & Pedestal Lights . . . . .	9-160	Latching Mechanism Crew Doors . . . . .	2-92
Instrument Maintenance . . . . .	8-1	Latching Mechanism-Crew Door . . . . .	F2-29
Instrument Panels . . . . .	8-315	Launcher and Adapter . . . . .	16-80
Instrument Premaintenance Requirements . . . . .	8-8	Lead Spool Resistor-Thermocouple . . . . .	8-111
Instruments-Engine . . . . .	8-10	Leveling and Jacking . . . . .	1-36
Instruments-Flight . . . . .	8-161	Lever Assembly+cyclic Controls, Tube and Levers and Supports-Cyclic Control System, Bell Cranks . . . . .	11-101
Instruments-Miscellaneous . . . . .	8-229	Lift Beam . . . . .	2-58
Instruments-Navigation . . . . .	8-219	Lift Beam Damage Limits and Repair . . . . .	F2-21
Intermediate Storage-Appendix E . . . . .	E-10	Lift Beam-Repair . . . . .	F2-22
Interior-Cleaning . . . . .	1-16	Lift Link-Pylon Mounts . . . . .	6-142
Interior Lights System . . . . .	9-140	Light—Anticollision . . . . .	9-211
Intermediate Gearbox (42°) . . . . .	6-179	Light System-Anticollision . . . . .	9-207
Inverter . . . . .	9-97	Light System-Caution . . . . .	9-169
Inverter Failure Relay . . . . .	9-111		

## ALPHABETICAL INDEX (Continued)

	<i>Paragraph</i>		<i>Paragraph</i>
Light-Transmission Oil Level .....	9-236	Main Rotor Hub and Blade Assembly .....	5-3
Lighting Provisions .....	9-138	Adjustment Collective Pitch Forces .....	5-8
Lighting System Instrument, 5 volt .....	9-86.1	Alignment .....	5-7
Lights-Cockpit .....	9-142	Automation RPM Adjusting .....	5-10
Lights-Dome .....	9-151	Cleaning .....	5-5
Lights-Navigation .....	9-222	Description .....	5-4
L i g h t s - N a v i g a t i o n - F l a s h e r	9-229	Installation .....	5-13
Lights System-Exterior .....	9-194	Lubrication .....	5-6
Limits Chart-Main Driveshaft Assembly,		Operational Check .....	5-9
P/N 205-040-004 .....	F6-10	Removal .....	5-12
Linear Actuator .....	4-118	Troubleshooting .....	5-11
Lines, Manifolds, Fittings and Screens .....	6-81	Main Rotor Mast Assembly .....	6-134
Lines Manifold, Fittings and Screens		Main Rotor System .....	5-1
Transmission Assembly .....	F6-19	Maintenance Allocation Chart .....	B-1
Litter Rack .....	16-15	Maintenance-Instrument .....	8-1
Loadmeter . . . . .	8-303	Manifold Assembly .....	10-53
Lower Case Repair-Transmission Assembly		Manifolds, Fittings, and Lines .....	6-81
( A V I M ) ... ..	6-37	Map and Data Case . . . . .	2-210
Lower Forward Cabin Windows .....	2-168	Mark 8 Sight Assembly . ....	16-97
Lubrication Chart . . . . .	F1-6	Master Caution Panel . . . . .	9-173
Lubrication Instructions .....	1-30	Master Guide-Aircraft Inventory Appendix C	C-1
Lubrication-Transmission Assembly .....	6-27	Metal Surfaces Bonded Panels-Repair of	
		Voids .....	F2-10
<b>M</b>		Mine Dispenser Control Panel .....	16-38
Machine Gun-M6 Subsystem 7.62MM, M60C	16-51	Mine Dispenser M56 . . . . .	16-43
Machine Gun M60D in Stowed Position		Mine Dispensing Subsystem .....	16-37
RS, Armament subsystem M23 . . . . .	F16-12	Minimum Breakaway Torque for Used All	
Machine Gun XM213, .50 Caliber.. . . . .	F16-22	Metallic and Nonmetallic Self-Locking Nuts	TI-7
Magnetic Brake-Cyclic Controls. . . . .	11-73	Miscellaneous Electrical Components .....	9-5
Magnetic Brake-Tail Rotor Controls .....	11-111	Miscellaneous Equipment .....	9-240
Magnetic Indicators-Radio (ID 998( )/		Miscellaneous Instruments .....	8-229
ASN and ID-250( )/ARN) .....	8-223	Mission Antenna Actuator System ....	9-289
Main and Tail Rotor System-Servicing .....	1-7	Mission Antenna Mount-Aft .....	9-310, F9-15
Main Beams at Station 129 (AVIM-Repair		Mission Antenna Mount-Forward .....	9-291, F9-11
of Cracked .....	2-65	Mission Antenna Mount Linear Actuator-	
Main DC Generator .....	9-60	Aft .....	9-316
Main Driveshaft P/N 205-040-004 . . . . .	6-13	Mission Antenna Mount Linear Actuator-	
Main Driveshaft Assembly-Limits Chart		Forward .....	9-297
P/N 205-040-004 .....	F6-10	Mission Antenna Mount Alignment Proce-	
Main Driveshaft Assembly and Installation		dure-Aft .....	9-322
P/N 205-040-004 .....	F6-9	Mission Antenna Mount Alignment Proce-	
Main Driveshaft-Inspection Criteria for		dure-Forward .....	9-303
Spherical Inner Couplings .....	F6-12	Mission Operator Seats .....	2-252.1, F2-48.1
Main Inverter Power Relay .....	9-105	Mixing Lever Assembly-Cyclic Controls . . .	11-87
Main Rotor Blade .....	5-27	Mooring .....	142
Main Rotor Blade, Composite <b>CB</b> . . . . .	5-34.2	Mooring Fittings .....	2-204
Main Rotor Hub .....	5-14	Motor Driven Shutoff Valve .....	10-39

ALPHABETICAL INDEX (Continued)

Paragraph	Paragraph
Mount and Adapter-M6 Subsystem 7.6MM, M60C Machine Gun.....	16-56
Muff Heater System Circuitry.....	9-273
M56 Mine Dispenser.....	16-43
<b>N</b>	
Navigation Instruments.....	8-219
Navigation Lights.....	9-222
Navigation Lights Flasher.....	9-229
Navigation Lights System.....	9-218
Navigation Lights System-Troubleshooting	T9-13
Nonessential Bus Relay.....	9-87
Non-Self-Purging Particle Separator.....	4-37
Non-Self-Purging Air Particle Separator- Inlet Screen.....	
Cleaning.....	4-34
Inspection.....	4-32
Installation.....	4-36
Removal.....	4-33
Repair.....	4-35
Nose Door.....	2-77
Nozzles, Registers, Gaskets and Misc Valves	13-4
<b>O</b>	
Oil Cooler Assembly.....	6-217
Oil Cooler Assembly.....	4-91
Oil Contamination, Chip Detector.....	4-101
Oil Debris Classification Chart (w/o ODDS)T6-5	
Oil Debris Classification Chart (w/ ODDS) .	F6-14.2
ODDS Power Module.....	9-163.4
Oil Filter-External.....	F6-57,6-204
Oil Filter-Transmission.....	641
Oil Jets.....	6-60
Oil Level Lights-Transmission.....	9-236
Oil Level Sight Gages.....	6-75
Oil Lines, Hoses, and Fittings.....	4-77
Oil Pressure Indicator-Engine.....	8-60
Oil Pressure Indicating System-Engines....	8-58
Oil Pressure Indicating System-Trans.....	8-259
Oil Pressure Indicator-Transmission.....	8-260
Oil Pressure Switch-Engine.....	4-147
Oil Pressure Transmitter-Engine.....	8-69
Oil Pressure Transmitter-Transmission.....	8-269
Oil Pump.....	650
Oil System.....	4-74
Oil System-Transmission.....	6-201
Oil Tank, Engine.....	4-84
Oil Temperature Bulb-Engine.....	8-90
Oil Temperature Bulb-Transmission.....	8-289
Oil Temperature Indicating System-Engine	8-78
Oil Temperature Indicating System- Transmission.....	8-278
Oil Temperature Indicator-Engine.....	8-80
Oil Temperature Indicator-Transmission ...	8-280
Outer Coupling Lubrication.....	F6-6
Overhaul and Retirement Schedule.....	T1-8
Overheat Switch.....	13-34
Overvoltage Relay.....	9-85
<b>P</b>	
Panel Assembly-Armament Control.....	16-89
Panel Assembly-Sight Light.....	16-93
Panel-Hinged.....	2-104
Panel-Master Caution.....	9-173
Panels-Cabin Floor.....	2-28
Paratroop Static Line Cable.....	2-192
Paratroop Static Line Cable.....	16-109
Parking.....	1-39
Part Numbers and Usable on Codes.....	4-138
Particle Separator-Non-Self-Purging.....	4-37
Particle Separator Self-Purging-Air Inlet Filters.....	45
Pedestal Lights-Instrument, Console.....	9-160
Pilots Collective Stick.....	11-25
Pilot-Static System.....	8-163
Plexiglass-Cleaning.....	1-18
Power Distributing System-Alternating Current.....	9-89
Power Distribution System-Direct Current .	9-1
Power Lever Controls.....	4-110
Power Plant Assembly.....	4-1
Power Plant Electrical Cable Installation....	4-153
Power Receptacle-External.....	9-47
Power Relay-External.....	9-54
Power Relay-Main Inverter.....	9-105
Power Relay-Spare Inverter.....	9-107
Power System-External.....	9-43
Power Turbine N2 Tachometer Generator Installation.....	8-22
Premaintenance Requirements-Instrument8-8	
Pressure Indicating System-Fuel.....	8-121
Pressure Indicating System-Torque.....	8-141



ALPHABETICAL INDEX (Continued)

	<i>Paragraph</i>		<i>Paragraph</i>
Pressure Indicator-Fuel .....	8-123	Relief Valve.....	7-39
pressure Indicator-Torque. ....	8-143	Repair of Cracked Spar Cap Angles on	
Pressure Relief Valve .....	6-67	Main Beams at Station 129 (AVIM) .....	2-65
Pressure Switch .....	7-53	Repair of Damage Penetrating Titanium	
Pressure Tranmitter-Fuel .....	8-132	and Fiberglass Facings and Core-Honey	
Pressure Transmitter-Torque .....	8-152	comb Panel.....	F2-11
Pylon Fifth Mount Support.....	2-62	Repair of Dents, Scars and Scratches	
Pylon Mounts and Lift Link .....	6-142	Honeycomb Panels .....	F2-6
		Repair of Voids in Metal Surfaces Bonded	
		Panels .....	F2-10
Q		Repair or Replacement-Transmission	
Quantity Indicating System-Fuel .....	8-241	(AVIM) .....	6-35
Quantity Indicator-Fuel .....	8-243	Replacement Chart-Connector .....	F-9
Quantity Transmitters-Fuel .....	8-252	Replacement Damaged Studs-Transmission	
Quill-Input Drive P/N 205-040-263 .....	6-101	Assembly (AVIM).....	6-36
Quill-Input Drive P/N 204-040-363 .....	6-92	Requirements .....	C-5
Quill-Generator Drive .....	6-109	Reservoir, Hydraulic .....	7-9
Quills-Input Drive.....	6-90	Rescue Hoist System Circuitry (Provisions)..	9-286
		Resistor-Thermocouple Lead Spool .....	8-111
		RRetirement Schedule .....	1-65
R		Return to Overhaul-Transmission Assembly	
Radar warning Indicating system (AN/		(AVIM) .....	6-38
APR-39) (When Installed) .....	8-314	Reverse Current Relay .....	9-81
Radio Magnetic Indicators		Rocket Launcher and Adapter .....	16-80
(ID-998 )/ASN and ID-250( )/ARN).....	8-223	Rocket System XM3 .....	16-76
Rearview Mirror. ....	2-175	RotorBlades-Cleaning .....	1-19
Receptacle-Engine Vibration Meter .....	9-120	Rotor Blades, Composite <b>CB</b> .....	5-34.2
Receptacle-External Power .....	9-47	Rotor Blades-Tail .....	5-114
Receptacle-Heated Blanket .....	9-276	Rotor Hub, Main .....	5-14
References Appendix A. ....	A-1	Rotor System Main.....	5-1
Registers, Gaskets and Miscellaneous		Rotor System Torque Values .....	F5-5
Valves-Ducts-Nozzles .....	13-4	Rotor Tachometer Generator .....	8-31
Regulator-Voltage .....	9-71	RPM Limit Warning Detector .....	9-186
Reinforced Floor Mounting Plates and		RPM Limit Warning Detector-Bench	
Base Assembly.....	F2-18.2, 2-27.1	Test set Up .....	F9-10
Relay		RPM Limit Warning Detector-Cables for	
Battery .....	9-39	Alignment .....	F9-9
Battery Feeder.....	9-41	RPM Limit Warning Detector-SDI Model.	F9-8
Bus Control .....	9-83	RPM Limit Warning Detector Models-	
External Power.....	9-54	Isolation of Circuits for Alignment .....	T9-9
Generator Field.....	9-79	RPM Limit Warning Detector-Saturn	
Inverter .....	9-109	Model.....	F9-7
Main Inverter Power.....	9-105	RPM Limit Warning Detector-SDI Model	F9-8
Nonessential Bus .....	9-87	RPM Limit Warning System .....	9-181
Overvoltage .....	9-85	RPM Limit Warning System-Trouble-	
Reverse Current.....	9-81	shooting.....	T9-10
Spare Inverter Power.....	9-107		

## ALPHABETICAL INDEX (Continued)

	<i>Paragraph</i>		<i>Paragraph</i>
<b>S</b>			
Saturn Model RPM Limit Warning Detector.	F9-7	Shunt-Generator.....	9-69
Scale and Friction Error Tolerances Plus or Minus °Celsius-EGT Indicator . . . . .	T8-6	Sight Assembly, Mark 8.....	16-97
Schedule-Retirement. ....	1-65	Sight Gages-Oil Level.....	6-75
Schematic Diagram-Combustion Air Blower	F13-6	Sight Light Panel Assembly.....	16-93
Schematic Diagram-Electric Motor Assembly	F12-6	Sight Station-M6 Subsystem 7.62MM M60C Machine Gun.....	16-68
Schematic Diagram-Fuel Quantity Installation (Crashworthy).....	F8-5	Siphon Breaker Valve.....	10-65
Schematic-Icing System Test Box.....	F9-3	Skid Saddles.....	3-26
Scissors and Sleeve Assembly.....	5-74	Skid Shoes.....	3-20
Screens Manifolds, Fittings . . . . .	6-81	Skid-Tail.....	2-298
Searchlight and Landing System.....	9-196	Skid Tubes.....	3-14
Seat Belts-Crew.....	2-241	Skin and Stringer Repair-Combined . . . . .	F2-15
Seat Belts-Troop.....	2-261	Skins-Sheet Metal.....	2-20
Seat Covers-Crew.....	2-225	Skins-Tailboom.....	F2-5
Seat Cover/Stencil-Crew . . . . .	F2-45	Sleeve Assembly, Scissors and . . . . .	5-74
Seat-Crew.....	F2-44	sling Loading.....	1-51
Seat-Crew-Armored . . . . .	2-247	Slip Indicator-Turn.....	8-201
Seating Arrangement.....	F2-49	Smoke Generator Subsystem . . . . .	16-21
Seating Arrangement (EH-IH).....	F2-49.1	Solenoid Valve-Start Fuel.....	9-136
Seats-Troop.....	2-253	Solenoid Valves.....	7-60
Self-Locking Nuts-Reuse . . . . .	1-29	Spar Cap Angles on Main Beams at Station 129 (AVIM).....	2-65
Service Deck-Right and Left . . . . .	2-19	Spar Cap Angle Repair.....	F2-24
Servicing . . . . .	1-1	Spare Inverter Power Relay . . . . .	9-107
Auxiliary Fuel System.....	1-4	Special Inspection,.....	1-58
<b>Battery</b> .....	1-12	Special Instructions-Engine Quick Change Assembly.....	4-136
Description.....	1-2	Special Tools and Test Equipment . . . . .	1-24
Engine oil System . . . . .	1-5	Special Tools and Test Equipment . . . . .	T1-2
Ground Handling wheel Pump.....	1-10	Spherical Couplings on Main Driveshaft- Inspection Criteria P/N 204-040-010 . . . . .	F6-3
Ground Handling wheel Tires.....	1-11	Splice Fabrication.....	F2-24.2
Hydraulic Reservoir . . . . .	1-9	splined Nut-Limits . . . . .	F6-4
Intermediate (42 degree) and Tail Rotor (90 degree) Gearboxes.....	1-8	Spool Resistor-Thermocouple Lead . . . . .	8-111
Mail and Tail Rotor System . . . . .	1-7	Spray Nozzle-Combustion Heater-Ex- ploded View.....	F13-4
Smoke Generator Subsystem Tank . . . . .	16-26	Stabilizer Bar Assembly.....	5-35
Transmission Oil System . . . . .	1-6	Standard Crew Seat.....	F2-44 2-216
Servicing Points Diagram.....	F1-1	Standard Torque Chart.....	T1-4
Servo Cylinder Assembly (Collective Control), Hydraulic.....	7-80	Standard Torque Procedures and Require- ments.....	1-28
Servo Cylinder Assembly (Cyclic Control), Hydraulic.....	7-67	Standard Torque Values-Engine Quick Change Assembly.....	4-137
Sheet Metal Skins.....	2-20	Standards of Serviceability.....	1-57
Sheet Metal Skins Forward Fuselage- Classification of Damage.....	T2-6	Standby Compass.....	8-225
Short Term Storage.....	E-3	Standby Compass-Troubleshooting . . . . .	T8-14
Shoulder Harness and Inertia Rcxl-Crew Standard Seat . . . . .	2-231	Standby Generator (Starter Generator) . . . . .	9-67
		Start Fuel Solenoid Valve.....	9-136
		Starter Generator . . . . .	9-126

## ALPHABETICAL INDEX (Continued)

	<i>Paragraph</i>		<i>Paragraph</i>
Starter-Generator Installation . . . . .	4-150	Tail Skid . . . . .	2-298
starting system . . . . .	9-122	Temperature Bulb-Engine Oil . . . . .	8-90
Static Line Cable-paratroop . . . . .	2-192, F2-43	Temperature Control Valve . . . . .	13-101
Static Line Cable, Paratroop . . . . .	16-109	Temperature-Millivolts vs . . . . .	T8-5
Storage of Aircraft-Appendix EL . . . . .	E-1	Test Box Schematic-Icing System . . . . .	F9-3
strap splice . . . . .	F2-24.3	Test Circuit (Crashworthy)-Indicator Bench . . . . .	F8-6
F u s e l a g e . . . . .	2-3, F2-2	Test Connections, Ground . . . . .	7-33
s tructure-Tailboom . . . . .	2-294	Testing Windshield Wiper . . . . .	F12-8
Structural Repair Materials . . . . .	T2-1	Thermal Valve . . . . .	6-211
Studs-Torque Values . . . . .	T1-6	Thermocouple Lead Spool Resistor . . . . .	8-111
Support Assemblies . . . . .	11-72.1	Thermostat-Cabin . . . . .	13-47
Support Equipment . . . . .	1-26	Tool Application-Use of Alignment Tool set (T47) . . . . .	F6-8
support-External Stores . . . . .	16-1	Torque Application . . . . .	F1-3
Support Fittings-Tail Rotor Driveshaft . . . . .	6-174	Torque Chart . . . . .	T1-4
Suppressor-Heat . . . . .	2-273	Torque Procedures and Requirements standard . . . . .	1-28
Swashplatc and Support Assembly . . . . .	5-57	Torque Values for Fluid Connectors . . . . .	T1-5
		Torque Values for Studs . . . . .	T1-6
		Torque Values, Standard—Engine Quick Change Assembly . . . . .	4-137
<b>T</b>		Towing . . . . .	1-34, F1-8
Tachometer Drive Quill-Hydraulic Pump . . . . .	6-118	Tracking and Operational Check . . . . .	5-120
Tachometer-Dual . . . . .	8-14	Tracks-Cargo Door . . . . .	2-137
Tachometer—Dual— Troubleshooting . . . . .	T8-1	Transformer-AC . . . . .	9-113
Tachometer Generator-Gas Producer . . . . .	8-49	Transmission and Engine Cowling . . . . .	F2-20
Tachometer Generator Installation Gas Producer N1 . . . . .	4-151	Transmission Assembly . . . . .	6-25
Tachometer Generator Installation, Power T u r b i n e N 2 . . . . .	4-152	Transmission Assembly-Build-up-Unit- versal . . . . .	F6-15
Tachometer Generator-Power Turbine . . . . .	8-22	Transmission Assembly and Gearboxes- Identification of Metal Particles . . . . .	6-30, F6-14
Tachometer Generator-Rotor . . . . .	8-31	Transmission Assembly (AVIM)-Replace- meat Damaged Studs . . . . .	6-36
Tachometer Indicating systems . . . . .	8-12	Transmission Assembly-Universal Basic configuration . . . . .	F6-18
Tachometer Indicator Producer . . . . .	8-40	Transmission Cowling . . . . .	2-37
Tailboom Assembly . . . . .	2-280	Transmission Oil Falter . . . . .	F6-20, 6-41, F6-21
Tailboom Skins . . . . .	F2-5	Transmission Oil Level Light . . . . .	9-236
Tailboom Structure . . . . .	2-294	Transmission Oil Level Light-Trouble- shooting . . . . .	T9-14
Tailpipe-Exhaust System . . . . .	4-67	Transmission Oil Pressure Indicating System . . . . .	8-258
Tailpipe Faking . . . . .	2-51	Transmission Oil Pressure Indicator . . . . .	8-260
Tail Rotor Blades . . . . .	5-114	Transmission Oil pressure Transmitter . . . . .	8-269
Tail Rotor Control Chain Conversion Pro- cedures . . . . .	11-154	Transmission Oil System . . . . .	6-201
Tail Rotor Control System . . . . .	11-108	Transmission Oil System-Servicing . . . . .	1-6
Tail Rotor Crosshead Controls . . . . .	5-107	Transmission Oil Temperature Bulb . . . . .	8-289
Tail Rotor Drive Quill . . . . .	6-125	Transmission Oil Temperature Indicating System . . . . .	8-278
Tail Rotor Driveshaft . . . . .	6-159		
Tail Rotor Driveshaft Support Flings . . . . .	6-174		
Tail Rotor Gearbox . . . . .	F6-52 6-190		
Tail Rotor Hub . . . . .	5-98		
Tail Rotor Hub and Blade Assembly . . . . .	5-88		
Tail Rotor Hydraulic Cylinder and Support . . . . .	11-163.1		
Tail Rotor System . . . . .	5-85		

## ALPHABETICAL INDEX (Continued)

	<i>Paragraph</i>		<i>Paragraph</i>
Transmission Oil Temperature Indicator . . . . .	8-280	Troubleshooting Cargo Suspension Assembly	T14-3
Transmission Vent Valve . . . . .	6-68	Troubleshooting Inverter System . . . . .	T9-5
Transmission Pressure Transmitter and Switch . . . . .	F6-16	Troubleshooting Landing and Search-Light system . . . . .	T9-11
Transmitter and Switch-Transmission Pressure . . . . .	F6-16	Troubleshooting Main Driveshaft P/N 205-040-004 . . . . .	616, T6-2
Transmitter-Engine Oil Pressure . . . . .	8-69	Troubleshooting Navigation Lights System .	T9-13
Transmitter-Fuel Pressure . . . . .	8-132	Troubleshooting RPM Limit Warning System	T9-10
Transmitter-Torque Pressure . . . . .	8-152	Troubleshooting Standby Compass . . . . .	T8-14
Transmitter-Transmission Oil Pressure . . . . .	8-269	Troubleshooting Starter System . . . . .	T9-6
Transmitters-Fuel Quantity . . . . .	8-252	Troubleshooting Torque Pressure Indicator..	T8-8
Repair or Replacement . . . . .	8-256	Troubleshooting-Transmission Oil Level Light . . . . .	T9-14
Treating Corroded Parts-Cleaning . . . . .	T2-4	Troubleshooting-Turn and Slip Indicator..	T8-12
Trigger Detent Mechanism. . . . .	11-64.1	Troubleshooting-Transmission Assembly . . .	T6-4
Troop Seat Belts . . . . .	2-261	Troubleshooting Vertical Velocity Indicator.	T8-13
Troop Seats . . . . .	2-253	Truck Ground Handling . . . . .	3-33
Troubleshooting-Air Distribution System Helicopters S/N 62-12351 through 64-13901	T13-1	Tube and Lever Assembly-cyclic Controls	11-65
Troubleshooting-Airspeed Indicator. . . . .	T8-9	Tubes-cyclic Control System Control.....	11-95
Troubleshooting Anti-Collision Light System	T9-12	Turn and Slip Indicator . . . . .	8-201
Troubleshooting-Attitude Indicator. . . . .	T8-1 1	Turn and Slip Indicator-Troubleshooting....	T8-12
Troubleshooting-Barometric Altimeter. . . . .	T8-10	Twenty Minutes Fuel Warning System Float Switch . . . . .	10-87
Troubleshooting Battery System. . . . .	T9-1		
Troubleshooting Clock . . . . .	T8-15	<b>U</b>	
Troubleshooting Cockpit Lights. . . . .	T9-8	UH-1H/V Composite Main Rotor Blade <b>CB</b>	F5-26.1
Troubleshooting Converter Assembly . . . . .	T12-3	Universal Transmission Assembly-Basic Configuration . . . . .	F6-18
Troubleshooting DC Voltmeter. . . . .	T8-17	Universal Transmission Assembly-Build-up	F6-15
Troubleshooting Dual Tachometer. . . . .	T8-1	Upper Door Window-Crew Door . . . . .	2-140
Troubleshooting-Electric Motor Assembly. . . . .	T12-2	Use of the Maintenance Allocation Chart ...	B-2
Troubleshooting Engine De-Ice Circuitry	T9-15	Use of Tool Set (T47)-Tool Application . . .	F6-8
Troubleshooting Engine Oil Pressure Indi- cator . . . . .	T8-2		
Troubleshooting Engine Oil Temperature Indicator. . . . .	T8-3	<b>V</b>	
Troubleshooting Exhaust Gas Temperature Indicator . . . . .	<b>T8-4</b>	Valve Control Temperature . . . . .	13-101
Troubleshooting External Power System	T9-2	Valve-Pressure Relief . . . . .	6-67
Troubleshooting Fire Detector _____	T12-1	Valve-Start Fuel Solenoid . . . . .	9-136
Troubleshooting Force Trim System Circuitry	T9-17	Valve-Thermal . . . . .	6-211
Troubleshooting Fuel Pressure Indicator . . . . .	T8-7	Velocity Indicator-Vertical . . . . .	8-210
Troubleshooting Fuel Quantity Indicator ....	T8-16	Vent Blower-Combustion Heater . . . . .	13-67
Troubleshooting Generator and DC Bus System (Helicopters Prior to S/N 66-746)..	T9-3	Ventilation Air Scoop Assemblies . . . . .	13-9
Troubleshooting Generator and DC Bus System (Helicopter S/N 66-746 and Sub- sequent) . . . . .	T9-4	Vertical Velocity Indicator.....	8-210
Troubleshooting 5-Volt Instrument Lighting system . . . . .	T9-4 1	Vibration Meter Receptacle--Engine . . . . .	9-120
Troubleshooting Governor Control System Circuitry . . . . .	T9-16	Vibrex Chart for Vertical l/Rev on UH-1H/V <b>CB</b> . . . . .	F5-87.1

## ALPHABETICAL INDEX (Continued)

	<i>Paragraph</i>
Voltage Regulatory. . . . .	9-71
Voltmeter-AC . . . . .	8-298
Voltmeter-DC . . . . .	8-300
Troubleshooting . . . . .	8-302

### W

Warning Detector-RPM Limit . . . . .	9-186
Warning Indicating System (AN/APR-39)	
When Installed. . . . .	8-314
Warning System-RPM Limit . . . . .	9-181
Wheels and Tire Assembly-Ground Handling	
Gear. . . . .	3-41
Window-Adjustable-Crew Door . . . . .	2-154
Window-Forward Crew Door. . . . .	2-147
Window-Upper-Crew Door . . . . .	2-140
Windows-Cabin-Lower Forward . . . . .	2-168
<b>Windows</b> -Cabin Roof . . . . .	2-161
Windows-Crew Door Remove/Install . . . . .	F2-42
Windshield. . . . .	2-133
Windshield and Windows Critical Areas	
and Repair Limits. . . . .	F2-41
Windshield Installation . . . . .	F2-40
Windshield Wiper. . . . .	12-9
Windshield Wiper Installation . . . . .	F12-2
Windshield Wiper System Circuitry . . . . .	9-280
Windshield Wiper—Testing . . . . .	F12-8
Wiper Shaft Positioning . . . . .	F12-5
Wiper System Circuitry-Windshield . . . . .	9-280
Wiper-Windshield. . . . .	12-9
Wiper Windshield-Installation . . . . .	F12-2
Wiring Data . . . . .	F-3
Abbreviations . . . . .	F-5
symbols. . . . .	F-6
Wiring Identification . . . . .	<b>F-4</b>
Wiring Diagram Index. . . . .	F-13

x , Y , z

RECOMMENDED CHANGES TO EQUIPMENT TECHNICAL PUBLICATIONS



THEN... JOT DOWN THE DOPE ABOUT IT ON THIS FORM, CAREFULLY TEAR IT OUT, FOLD IT AND DROP IT IN THE MAIL!

SOMETHING WRONG WITH THIS PUBLICATION?

FROM (PRINT YOUR UNIT'S COMPLETE ADDRESS)  
 CDR, 1st Br, 65th ADA  
 ATTN: SP4 J. Brown  
 Key West, FL 33040

DATE SENT  
 10 Jun 79

PUBLICATION NUMBER  
 TM 9-1430-550-34-1

PUBLICATION DATE  
 7 Sep 72 .

PUBLICATION TITLE Unit of Radar Set  
 AN/MPQ-50 Tested at the HFC

BE EXACT PIN-POINT WHERE IT IS

PAGE NO	PARA-GRAPH	FIGURE NO	TABLE NO
9-19		9-5	
21-2	step 1C	21-2	

SAMPLE

IN THIS SPACE TELL WHAT IS WRONG AND WHAT SHOULD BE DONE ABOUT IT:

"B" Ready Relay K11 is shown with two #9 contacts. That contact which is wired to pin 8 of relay K16 should be changed to contact #10.

Reads: Multimeter B indicates 600 K ohms to 9000 K ohms.

Change to read: Multimeter B indicates 600 K ohms minimum.

Reason: Circuit being checked could measure infinity. Multimeter can read above 9000 K ohms and still be correct.

PRINTED NAME, GRADE OR TITLE AND TELEPHONE NUMBER  
 SP4 J.T. Brown, Jr.

SIGN HERE  
 SP4 James Brown, Jr.

TEAR ALONG PERFORATED LINE

FILL IN YOUR  
UNITS ADDRESS



FOLD BACK

DEPARTMENT OF THE ARMY

---

---

OFFICIAL BUSINESS

COMMANDER  
U.S. ARMY AVIATION AND TROOP COMMAND  
ATTN: AMSAT-I-MP  
4300 GOODFELLOW BOULEVARD  
ST. LOUIS, MO 63120-1798

TEAR ALONG PERFORATED LINE





1 Nov 80

FILL IN YOUR  
UNITS ADDRESS  
↓

FOLD BACK

DEPARTMENT OF THE ARMY

---

---

OFFICIAL BUSINESS

COMMANDER  
U.S. ARMY AVIATION AND TROOP COMMAND  
ATTN: AMSAT-I-MP  
4300 GOODFELLOW BOULEVARD  
ST. LOUIS, MO 63120-1798

TEAR ALONG PERFORATED LINE

RECOMMENDED CHANGES TO EQUIPMENT TECHNICAL PUBLICATIONS

**SOMETHING WRONG WITH THIS PUBLICATION?**



THEN JOT DOWN THE DOPE ABOUT IT ON THIS FORM. CAREFULLY TEAR IT OUT. FOLD IT AND DROP IT IN THE MAIL!

FROM (PRINT YOUR UNIT'S COMPLETE ADDRESS)

DATE SENT

PUBLICATION NUMBER

TM 55-1520-210-23-3

PUBLICATION DATE

30 SEP 87

PUBLICATION TITLE

AVUM AND AVIM MAINTENANCE INSTRUCTIONS UH-1H/V/EH-1H/X

BE EXACT PIN-POINT WHERE IT IS

PAGE NO

PARA-GRAPH

FIGURE NO

TABLE NO

IN THIS SPACE TELL WHAT IS WRONG AND WHAT SHOULD BE DONE ABOUT IT:

PRINTED NAME GRADE OR TITLE AND TELEPHONE NUMBER

SIGN HERE

1 Nov 80

FILL IN YOUR  
UNITS ADDRESS



FOLD BACK

DEPARTMENT OF THE ARMY

---

---

OFFICIAL BUSINESS

COMMANDER  
U.S. ARMY AVIATION AND TROOP COMMAND  
ATTN: AMSAT-I-MP  
4300 GOODFELLOW BOULEVARD  
ST. LOUIS, MO 63120-1798

TEAR ALONG PERFORATED LINE

# SOMETHING WRONG WITH THIS PUBLICATION?



THEN JOT DOWN THE DOPE ABOUT IT ON THIS FORM. CAREFULLY TEAR IT OUT. FOLD IT AND DROP IT IN THE MAIL.

FROM (PRINT YOUR UNIT'S COMPLETE ADDRESS)

DATE SENT

PUBLICATION NUMBER

TM 55-1520-210-23-3

PUBLICATION DATE

30 SEP 87

PUBLICATION TITLE

AVUM AND AVIM MAINTENANCE INSTRUCTIONS UH-1H/V/EH-1H/X

BE EXACT PIN-POINT WHERE IT IS

PAGE NO

PARA-GRAPH

FIGURE NO

TABLE NO

IN THIS SPACE TELL WHAT IS WRONG AND WHAT SHOULD BE DONE ABOUT IT:

PRINTED NAME GRADE OR TITLE AND TELEPHONE NUMBER

SIGN HERE

FILL IN YOUR  
UNITS ADDRESS



FOLD BACK

DEPARTMENT OF THE ARMY

---

---

OFFICIAL BUSINESS

COMMANDER  
U.S. ARMY AVIATION AND TROOP COMMAND  
ATTN: AMSAT-I-MP  
4300 GOODFELLOW BOULEVARD  
ST. LOUIS, MO 63120-1798

TEAR ALONG PERFORATED LINE

The following format must be used if submitting an electronic 2028. The subject line must be exactly the same and all fields must be included; however only the following fields are mandatory: 1,3, 4, 5 6, 7, 8, 9, 10, 13, 15, 16, 17, and 27.

From: 'Whomever' <whomever@avma27.army.mil>  
To: <mpmtYoavma28@st-louis-emh7.arny.mil>  
Subject: DA Form 2028

1 **From:** Joe Smith  
2 Unit: home  
3 **Address:** 4300 Park  
4 **City:** Hometown  
5 **St.:** MO  
6 **Zip:** 77777  
7 **Date Sent:** 19-OCT-93  
8 **Pub no:** 55-2840-229-23  
9 **Pub Title:** TM  
10 **Publication Date:** 04-JUL-85  
11 Change Number: 7  
12 Submitter Rank: MSG  
13 **Submitter FName:** Joe  
14 Submitter MName: T  
15 **Submitter LName:** Smith  
16 **Submitter Phone:** 123-123-1234  
17 **Problem: 1**  
18 Page: 2  
19 Paragraph: 3  
20 Line: 4  
21 NSN: 5  
22 Reference: 6  
23 Figure: 7  
24 Table: 8  
25 Item: 9  
26 Total: 123  
27 **Text:**

This is the text for the problem below line 27.

**PIN: 040153-008**