

URGENT

*TB 1-1520-210-30-01

DEPARTMENT OF THE ARMY TECHNICAL BULLETIN

MANDATORY RECURRING INSPECTION OF TAIL BOOM VERTICAL FIN SPAR ASSEMBLY FOR ALL UH-1 SERIES AIRCRAFT

Headquarters, Department of the Army, Washington, D. C.
4 November 2005

DISTRIBUTION STATEMENT A: Approved for public release; distribution is unlimited.

NOTE

THIS PUBLICATION IS EFFECTIVE UNTIL RESCINDED OR
SUPERSEDED.

NOTE

As a result of message UH-1-00-05, new or changed text will be
indicated by a vertical line, changes to illustrations will be indicated
by a miniature pointing hand.

NOTE

This publication contains improved guidance for X-ray inspection
exposure #3 and for the daily inspection of the area forward of the 90
degree gearbox mount which were not contained in previous
procedures put on the web dated 5/28/99 and those sent out through
the LAR's dated 5/28/99.

1. Priority Classification. URGENT

NOTE

See AR 95-1, paragraph 6-6.a., for exception authority of major
commanders.

a. Aircraft in Use. Upon receipt of the TB the condition status symbol of the cited aircraft will be changed to a **Red Horizontal Dash //--//**. The **Red Horizontal Dash //--//** entry shall state "Inspect Tail Boom Vertical Fin Spar Assembly IAW UH-1-00-05 (TB 1-1520-210-30-01, dated March 2000) at the next 75 Flight Hour Special Inspection and, as applicable IAW paragraph 9.b., submit the most recent X-ray to AMCOM NLT 25 Feb 2000." The **Red Horizontal Dash //--//** may be cleared when both the inspection of paragraph 8 and correction of paragraph 9 are completed. The affected aircraft shall be inspected at the next scheduled 75 hour special inspection. Failure to comply with the requirements of this message within the time frame specified will cause the status symbol of the affected aircraft to be upgraded to a **Red //X//**.

b. Aircraft in Depot Maintenance. Same as paragraph 1.a.

*This TB supersedes TB 1-1520-210-30-01, dated 22 March 2000, USAAMCOM Safety of Flight Messages UH-1-00-05, 081544Z Feb 00 and UH-1-99-03, 281815Z, May 1999.

c. Aircraft Undergoing Maintenance. Same as paragraph 1.a.

d. Aircraft in Transit. Same as paragraph 1.a.

e. Maintenance Trainers (Category A and B). Same as paragraph 1.a.

f. Component/Parts in Stock at All Levels (Depot and Others) Including War Reserves.

Accomplish the following if not previously complied with. Upon receipt of this TB the materiel condition tags of all items in all condition codes listed in paragraph 6 shall be annotated to read "SOF UH-1-99-03 (TB 1-1520-210-30-01), Mandatory inspection of tail boom vertical fin spar assembly, not complied with".

(1) Wholesale Stock – Report receipt of the message/TB IAW paragraph 14.c.(1). Upon receipt of the message or this TB (whichever occurs first), all serviceable items (condition codes A, B, C, D, and E) listed in paragraph 6 located in wholesale depot storage shall be placed in condition code "J" and tagged with a suspended tag/label – Material, DD Form 1576/DD Form 1576-1. Do not remove original condition tags. Report compliance with this TB IAW paragraph 14.d.(1).

(2) Retail Stock – Report receipt of the message/TB IAW paragraph 14.c.(2). Upon receipt of the message or this TB (whichever occurs first), commanders and others maintaining retail stock at installation level and below shall contact the supported aviation unit to perform the inspection required by paragraph 8 and the correction procedures of paragraph 9 on discrepant materiel. Disposition of discrepant materiel will be IAW paragraph 10.d. Report compliance with this TB IAW paragraph 14.d.(2).

g. Components/Parts in Work (Depot Level and Others). Items listed in paragraph 6 in work will not be issued until compliance with this TB.

2. Task/Inspection Suspense Date.

a. At the next scheduled 75 hour special inspection.

b. Submittal of X-rays IAW paragraph 9.b. NLT 25 Feb 2000.

3. Reporting Compliance Suspense Date. No later than 1 Mar 2000, IAW paragraph 14.a. of this TB.

4. Summary of the Problem.

a. Background.

(1) SOF UH-1-99-03 required inspection of the vertical fin spar for cracks and debonding. Detailed inspection procedures were provided in the previous version of TB 1-1520-210-30-01 dated 9 June 1999 that were not included in the message version of SOF UH-1-99-03.

(2) The SOF stated that if the vertical fin spar is found cracked, the boom assembly shall not be used. The UH-1 maintenance manual, TM 55-1520-210-23-1, allows for repair of vertical fin spar cracks near the 90 degree gearbox mount attachment area. It has been determined that this repair is acceptable and may continue to be used providing that a recurring visual inspection be performed on the spar for crack growth.

(3) SOF UH-1-99-03 (TB 1-1520-210-30-01 dated 9 June 1999) required at least two thirds of countersunk rivet on exposure #3 to be visible to be an acceptable X-ray. Reports have since been received that show cracks emanating from the top/upper edge of the rivet hole. These cracks would not be found using the two thirds criteria. For this reason, the entire circumference of the countersunk rivet is required to be visible on the X-ray film.

(4) AMCOM has received and confirmed several reports which indicate the X-ray procedure of TB 1-1520-210-30-01 dated 9 June 1999, is being performed improperly. Aircraft that were inspected by any entity other than an ARNG Aviation Classification Repair Activity Depot (AVCRAD) are of particular concern (Refer to second note at the beginning of paragraph 8).

b. For manpower/downtime and funding impacts see paragraph 12.

c. The purpose of message SOF UH-1-99-03 was to revise TB 1-1520-210-30-01, dated 9 June 1999 to:

- (1) Allow repair of cracks in the verticle fin spars near the 90 degree gearbox mount IAW the UH-1 maintenance manual.
- (2) Require the entire circumference of the countersunk rivet of exposure #3 to be visible on the radiograph.
- (3) Require the submittal of one set of X-ray film for review, if applicable.
- (4) Clarify location of crack initiation.
- (5) Provide disposition of cracked tailbooms.

5. **End Items to be inspected.** All UH-1 series aircraft.

6. **Assembly Components to be Inspected.**

NOMENCLATURE	PART NUMBER	NATIONAL STOCK NUMBER
Tail Boom Assembly	205-032-800-71	1560-00-483-1273
Tail Boom Assembly	205-032-800-101	1560-01-160-6623
Tail Boom Fin Assembly	205-030-899-109	1560-00-482-9100

7. **Parts to be Inspected.**

NOMENCLATURE	PART NUMBER	NATIONAL STOCK NUMBER
Tail Boom Fin Spar	205-030-846-49	1560-00-428-7321
Tail Boom Fin Spar	205-030-846-7	1560-00-431-8495

8. **Inspection Procedures.**

NOTE

Remove the eight rivets (fasteners) and replace them at the next 75 hour special inspection IAW SOP UH-1-99-03 (TB 1-1520-210-30-01, dated 9 June 1999). There is no requirements to initiate this action before the next scheduled 75 hour inspection.

NOTE

Incorporate these revised inspection procedures into the next 75 hour special inspection IAW SOP UH-1-99-03 (TB 1-1520-210-30-01, dated 9 June 1999). There is no immediate requirement to inspect the tailboom before the next scheduled 75 hour inspection.

NOTE

Determine if the current X-ray inspections were performed by an ARNG AVCRAD X-ray team or an AMCOM approved source IAW paragraph 9.b. Report IAW paragraph 9.b.

a. Tail Boom Fin Spar Assembly, Part Number 205-030-846-(all dash numbers), shall be inspected as specified herein. The area of concern is the Left Hand Vertical Fin Spar Cap shown in Figure 1. These inspections pertain to the left-hand spar cap only.

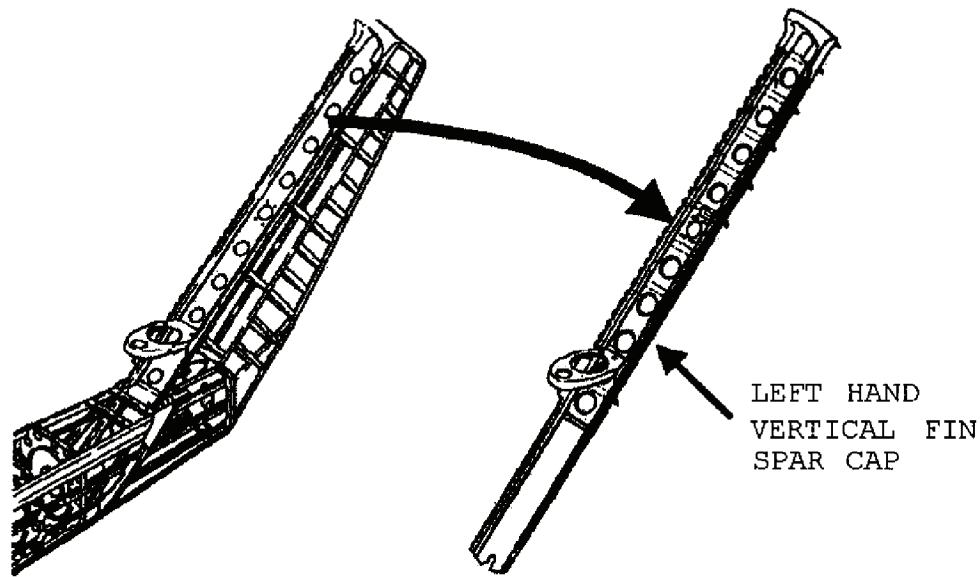

Figure 1: Vertical Fin Spar

b. Inspection Intervals – The following inspection intervals shall be adhered to:

NOTE

The 75 hour inspection will be carried as a write-up on the DA Form 2408-18. When the tail boom assembly is moved from one aircraft to another (controlled exchange) the DA Form 2408-5-1 for the tail boom assembly will be annotated to show the hours remaining until the next 75 hour inspection to insure that the DA Form 2408-18 is updated correctly. ULLS-A units will use inspection number A170.

- (1) X-ray Inspection – Immediately upon receipt of SOF UH-1-99-03 and recurring thereafter every 75 hours.
- (2) Tap Hammer Inspection – Immediately upon receipt of SOF UH-1-99-03 and recurring thereafter at every phase inspection.
- (3) Visual Inspection of Spar – Immediately upon receipt of SOF UH-1-99-03 and recurring after the last flight of each day thereafter.

c. Preparation for Inspection.

- (1) Prepare helicopter for safe ground maintenance.
- (2) Remove the intermediate (42 degree) gearbox cover and open the tail rotor driveshaft cover on the vertical fin.
- (3) Remove aft tail boom inspection door, Item 42, Figure 15, TM 55-1520-210-23P-1, located on the underneath side of the tail boom at station 180.
- (4) Remove small inspection panels, Item 124, Figure 16, TM 55-1520-210-23P-1, on both sides of the tail boom, directly beneath vertical fin.

d. X-ray Inspection:**WARNING****Radiation Hazard**

Assure compliance with all applicable safety precautions set forth in TM 1-1500-335-23 (Nondestructive Inspection Methods manual) listed in table 1.1. A hazard associated with exposure to ionizing radiation is that serious injury can be inflicted without pain, burning, or other sense of discomfort during the exposure period. Radiation protection shall be utilized in accordance with AR40-14/DLAR 1000.28. Safety zones for Exposures #1, #2, and #3 are shown in figures 1A and 1B.

NOTE

Personnel performing this radiographic procedure shall have training through the Education and Training Command (AETC) (previously at Millington, Tennessee, or currently at Pensacola, Florida) or DOD and non-DOD personnel shall be a Certified Level II Radiographer IAW NAS410. For assistance contact the NDI point of contact at paragraph 16.b..

NOTE

The use of alternate radiographic equipment must be approved by the NDI point of contact at paragraph 16.b. Alternate radiographic equipment must meet the required 2-2T sensitivity.

- (1) The areas of interest are the first ten rivets on the left hand side of the vertical tail fin attaching the tail fin skin to the forward left hand fin spar cap, and the first three rivets on the left hand fin spar horizontal web flange below the tail boom interface. Three separate radiographs are required to properly cover the area of interest.
- (2) Equipment and Materials required:
 - LORAD X-ray Unit, LPX160 or Equivalent NSN 6635-01-417-1830
 - LORAD Laser Pointer
 - Tripod, X-ray tube head stand
 - Film processing Equipment
 - Kodak Radiographic Film, Catalog Number 1459023, 35mm x 200 ft., Industrial X-ray, M Speed Redipack
 - .25 and .37 inch aluminum penetrameters
 - 1 Inch Black Duct Tape, NSN 7510-00-074-4960
 - Marking Material, refer to TM 1-1520-256-23, Table 1-8
 - Tape Measure
 - Plumb Bob
- (3) Remove lockwire and disconnect the tail rotor control cable, Item 4, Figure 11-29, TM 55-1520-210-23-2, at the barrel assembly, Item 5. Remove the four bolts securing the Pulley Bracket Assembly, Item 43, and position the assembly aside to allow access to the vertical fin spar cap at the canted bulkhead.
- (4) Remove any surface contaminants from the forward left hand spar cap, in the area of interest, with a cloth dampened with aliphatic naphtha (TT-N-95, Type 2, NSN 6810-00-238-8119). Paint removal is not required.

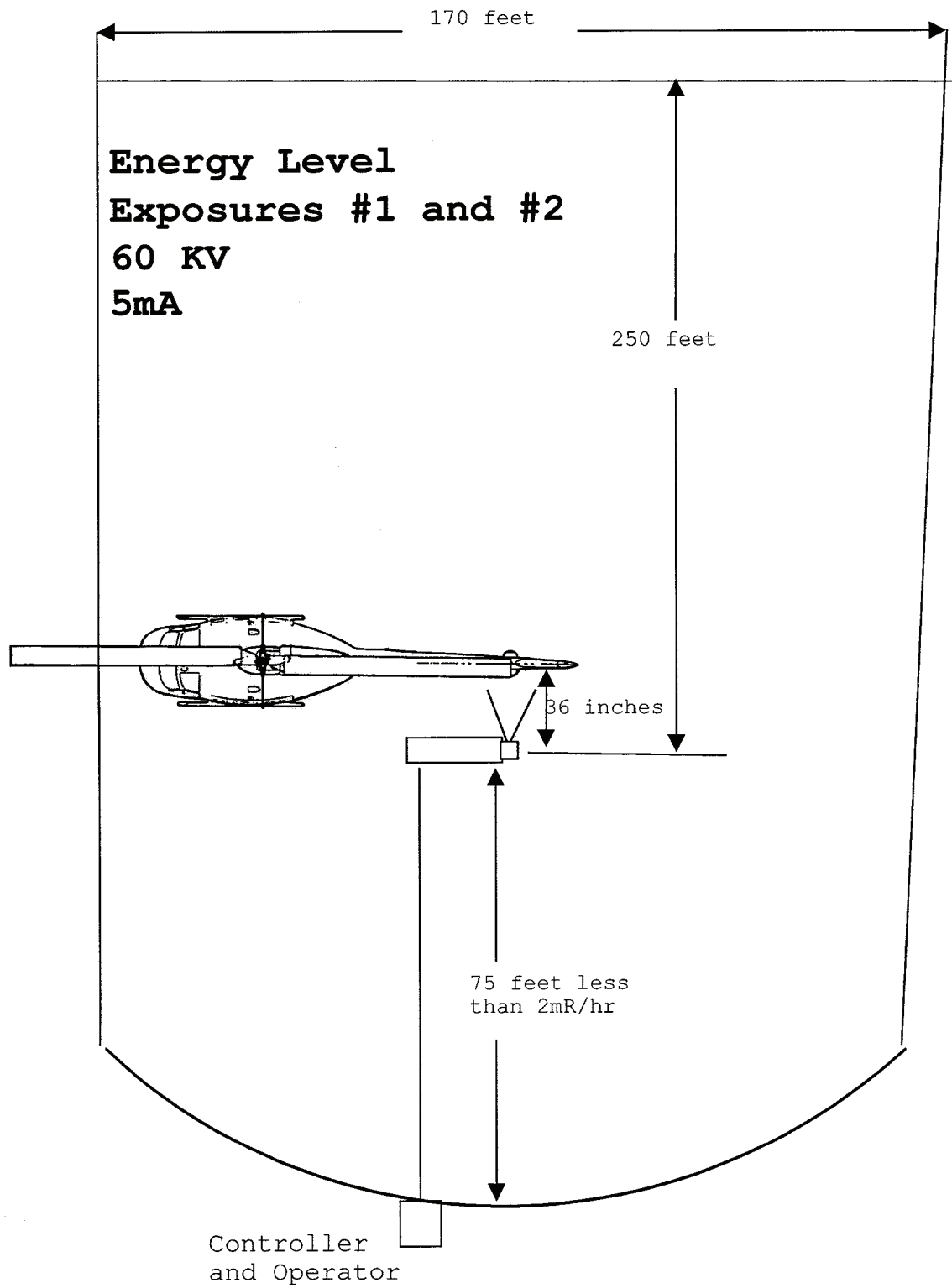

Figure 1A, Safety Zone for Exposures #1 and #2

Energy Level
Exposure #3
75 KV
5mA

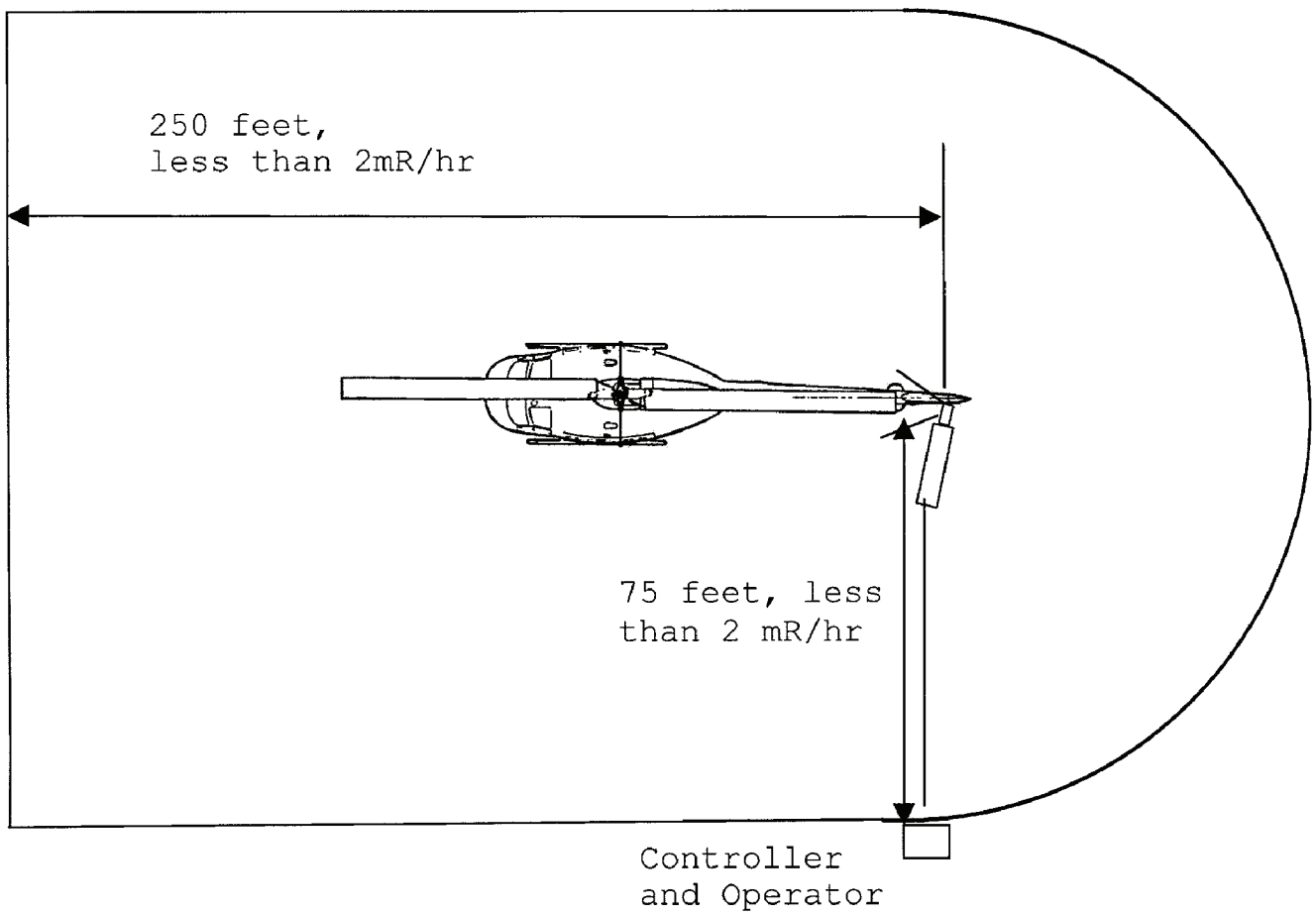

Figure 1B, Safety Zone for Exposure #3

(5) Equipment settings, inspection data, and arrangement for each exposure are given in Figure 2, Radiographic Parameters.

RADIOGRAPHIC INSPECTION DATA						
EXPOSURE NUMBER	KV	MA	FFD (INCHES)	TIME (Min/Sec.)	FILM	
					TYPE	SIZE
E1 & E2	60	5	36	2m 30s	M	1.4in. x 14in.
E3	75	5	49	2m 45s	M	1.4in. x 14in.
REMARKS						
1. Radiograph lead ID must contain aircraft serial number. 2. The penetrameter outline and 2T hole must be visible to qualify the radiograph's sensitivity level. 3. Film density SHALL be 2.0 to 2.8 H&D units in the area of interest. 4. Exposure time may be changed as required to achieve film density. (Reference TM 1-1500-335-23)						

Figure 2: Radiographic Parameters

(6) In a darkroom environment, cut three strips of film 14 inches long and seal cut edge with duct tape. Very carefully trim off excess tape. Light leaks, especially on exposure number 3, will render the film unacceptable and require another exposure to be taken.

(7) Remove the sealant where the vertical fin spar penetrates the tail boom skin and where the spar cap meets the 42 degree gearbox support angle inside the tail boom.

(8) Position film on the inboard side of the vertical fin spar cap leg (See Figure 3) with the **"correct side facing the radiation source"**. Place the lead identification nameplate outside the area of interest. Include the complete aircraft tail number and rivet numbers being viewed (Rivets 1-5 or 6-10).

Position Film on
 Inboard side of
 Vertical Fin Spar
 Cap for Exposures
 #1 and #2.

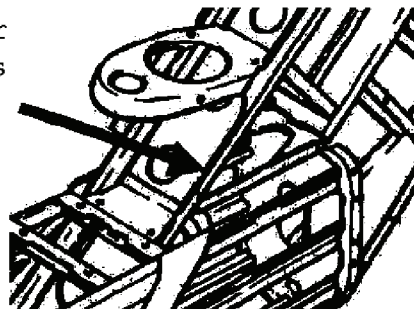

Figure 3: Placement of Film for Exposures 1 and 2

(9) Position a 0.25 inch aluminum penetrameter between rivets 5 and 6 with the 2T hole in line with the center of the rivet row (See Figure 4). Secure the penetrameter using tape over the lead numbers and 4T hole only, this will eliminate possible interpretation errors from indications generated by the edges of the tape.

(10) Exposure Number 1: Position the X-ray tube (See Figure 5), centering the radiation beam on rivet #3. (See Figure 4).

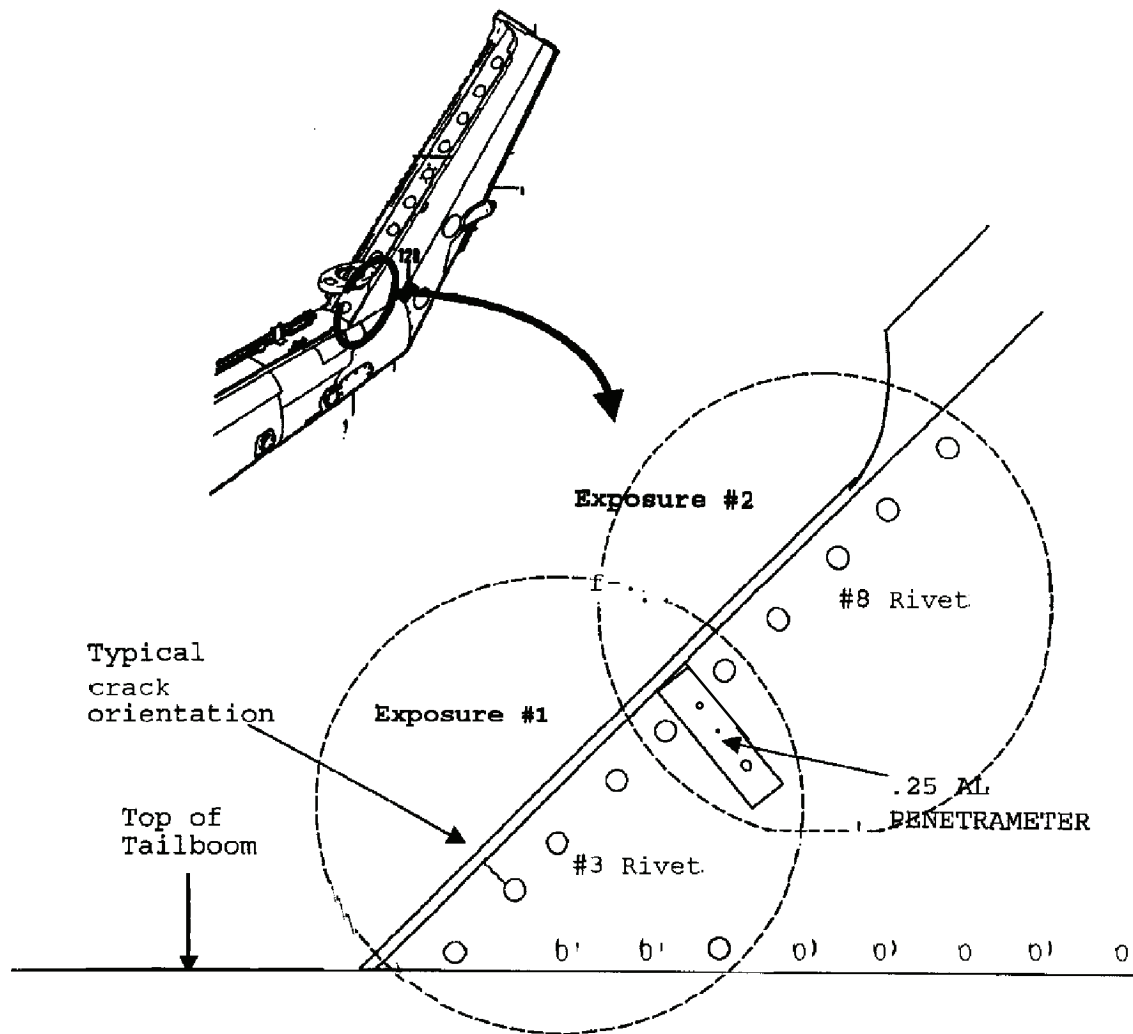

Figure 4: Radiographic Exposures #1 and #2

(11) Set the X-ray unit to values given in the Radiographic Inspection Data chart, Figure 2, for the exposure.

(12) Expose film.

(13) Remove film and reposition an unexposed piece of film to make exposure number 2.

(14) Exposure Number 2: Reposition the X-ray tube head centering the radiation beam on rivet #8. (See Figure 4).

(15) Expose the film.

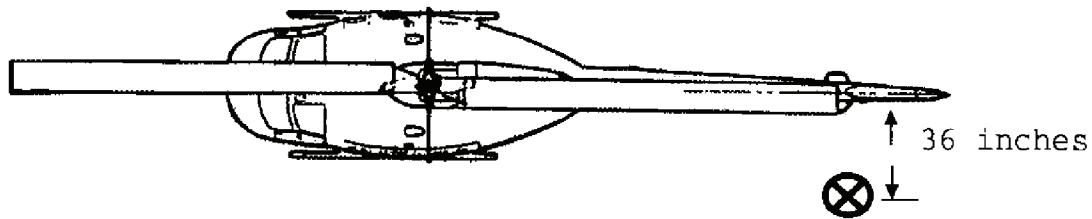

Tubehead Position for Exposure #1 and #2

Figure 5: X-ray Tube Head Position

NOTE

Exposure Number 3 is designed to show the area of the first three rivets on the left hand fin spar horizontal web flange below the tail boom interface. The upper most (first) rivet is countersunk on the upper side of the spar and is difficult, if not impossible to see with the naked eye.

(16) Exposure Number 3: Use a piece of stainless steel (15.0 in. L. x 1.0 in. W. x 0.050 in. T.) as a positioner to assist with film placement. Tape the film to the positioner leaving 0.50 inch of film extending beyond the end of the positioner. Place film as shown in Figure 6. Place the film with the "correct side facing the radiation source". Place the lead identification nameplate outside the area of interest. Include the complete aircraft tail number, date, and exposure number (E3).

(17) Position a 0.37 inch aluminum penetrameter under the butt of the countersunk rivet. Align the 2T hole with the center of the rivet row. This will allow the 2T hole to be visible in the area of interest (See Figure 7). Secure the penetrameter using tape over the lead numbers and 4T hole only, this will eliminate possible interpretation errors from indications generated by the edges of the tape.

(18) Position the X-ray tube head for exposure number 3. Attach a plumb bob string to the right side vertical fin inspection cover forward of the tail light as shown in figure 8a. Position the tube head center line in line with the plumb bob string, 45 inches below the inspection cover fastener. (See Figure 8a and 8b)

(19) Place the laser pointer on the tube head. Activate the laser pointer and slide the tube head horizontally until the laser dot aligns with the left hand stringer rivet row, Figure 9. This will achieve a 49 inch source-to-film distance measured from the 42 degree gearbox cover aft, left hand, Zeus fastener receptacle to the center of the X-ray tube head (See Figure 8b). Verify perpendicularity by rotating the tube head to verify the laser dot tracks with the first ten rivets. Adjust the tube head horizontally as required. Center the laser dot on rivet number 6.

(20) Fine tune tube head position as follows: (See Figure 9)

(a) Move the tube head outboard end forward, until the laser point comes in line with the center rivet row. Maintain the anode center line with the plumb bob.

(b) Carefully move the tube head horizontally outboard maintaining tube head angle until the laser dot aligns with the left hand rivet row.

(c) Rotate the head to place the laser dot on rivet number 6. This sets the appropriate tube head angle forcing the overlapping stringer image off of the area of interest.

(21) Set the X-ray unit to values given in the Radiographic Inspection Data chart, Figure 2, for the exposure.

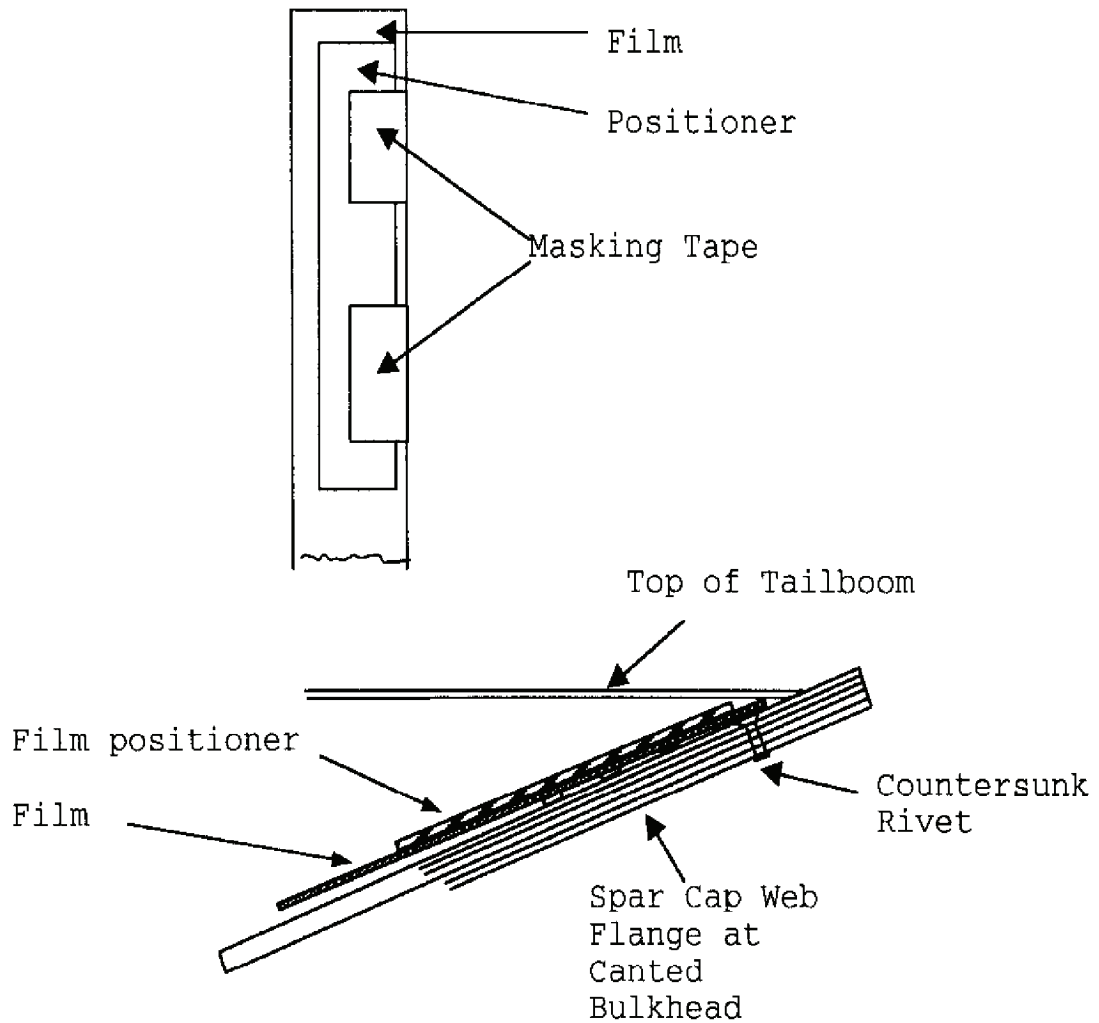

NOTE: It is important that the film be placed as far up the spar web flange and as far outboard (into the nested angle) as possible to assure that the first rivet is exposed on the film

Figure 6. Placement of Film for Exposure 3

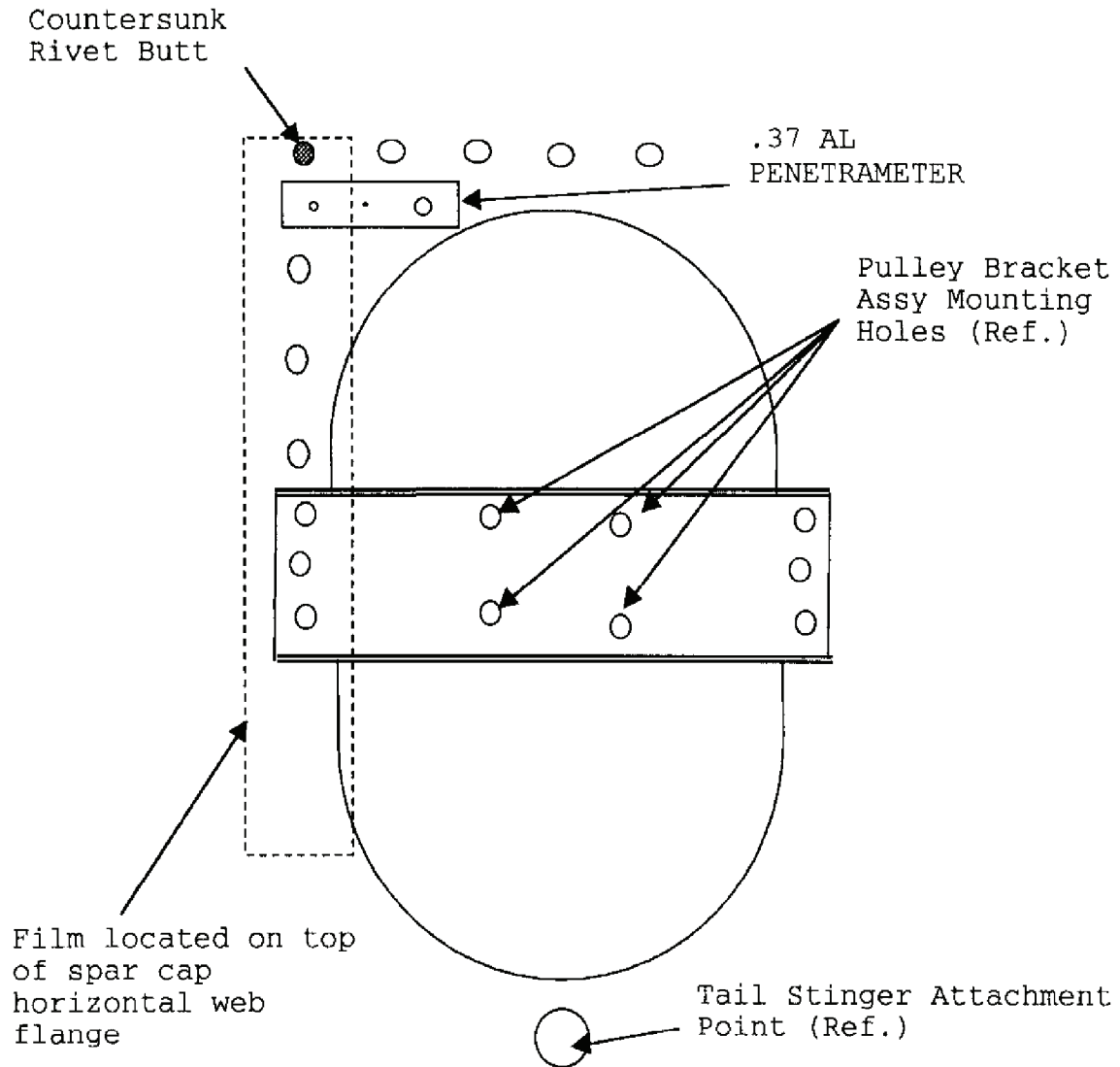

View looking forward at canted bulkhead through inspection panels, Item 124, Figure 16, TM 55-1520-210-23-P1

Figure 7: Radiographic Exposure #3

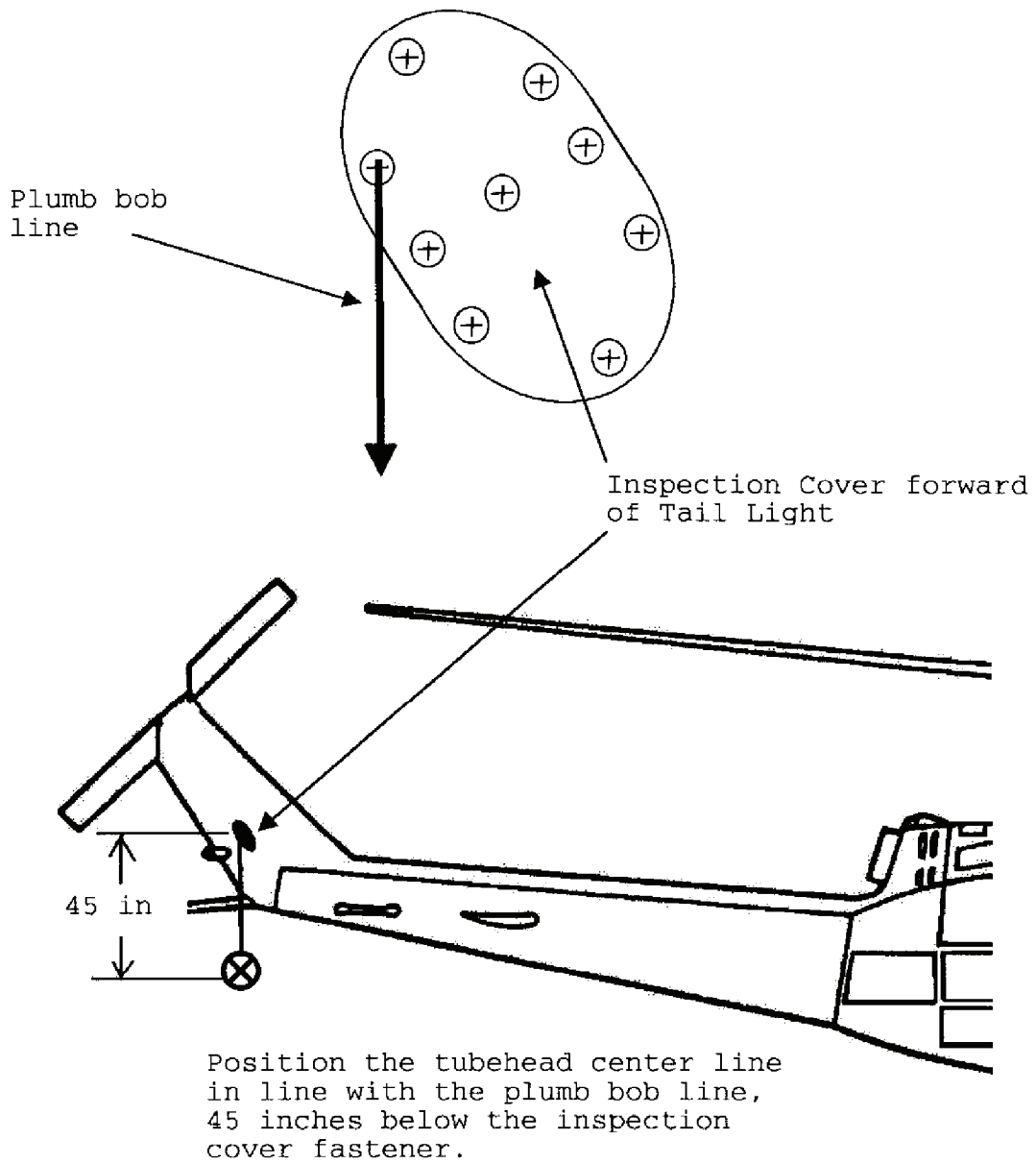
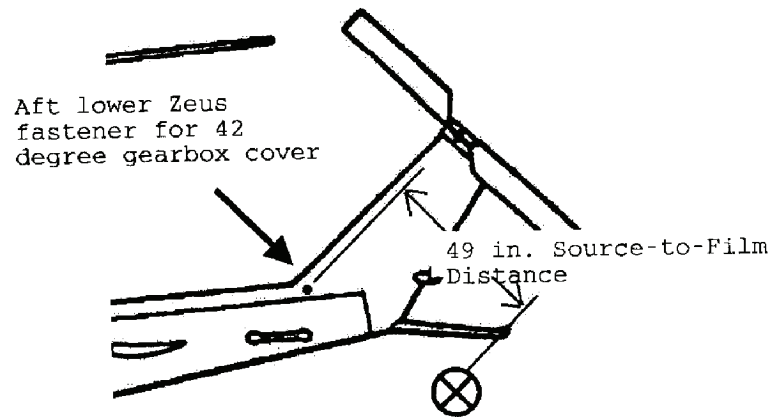

Figure 8a: X-ray Tube Head Position for Exposure #3



Positioning the tube head in line with the plumb bob achieves a 49 inch source-to-film distance, measured from the 42 degree gearbox cover aft, left hand, lower Zeus fastener receptacle to the center of the x-ray tube head.

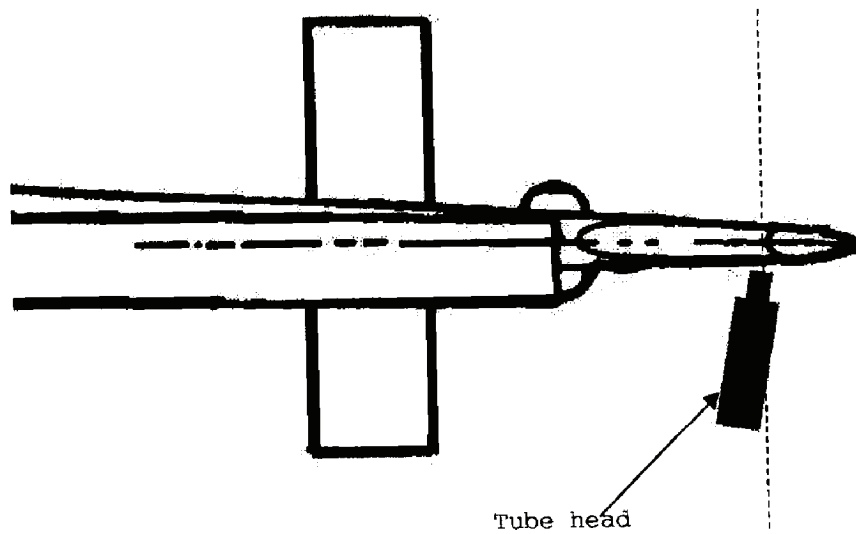

Figure 8b: X-ray Tube Head Position for Exposure #3

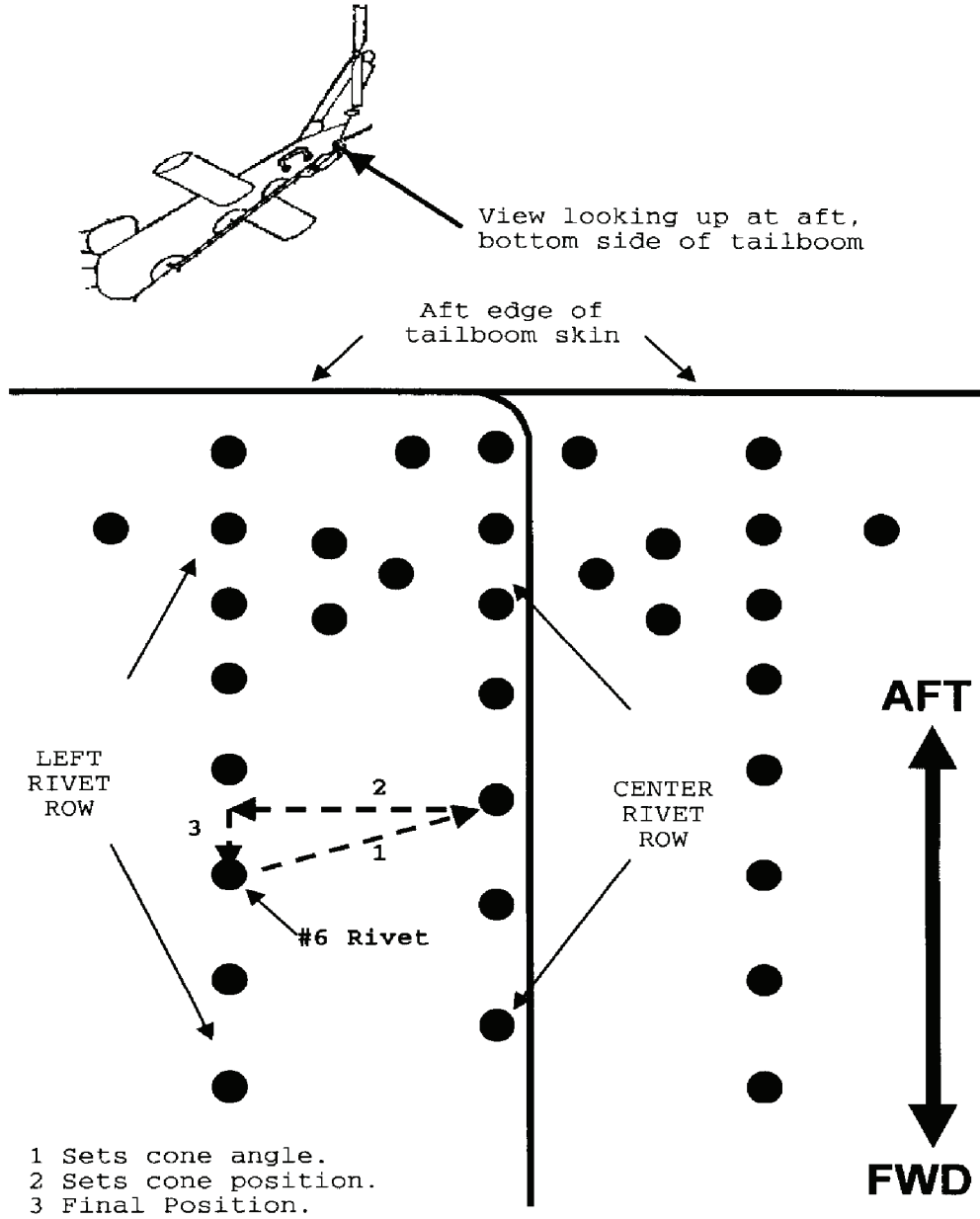

Figure 9: X-ray Tube Head Position for Exposure #3

(22) Expose film.

NOTE

A crack will appear as a dark, fine, line usually emanating from a rivet hole, and propagating toward the edge of the spar cap in either direction. (See Figure 4) A skin crack will appear similar to a spar crack.

(23) Process films IAW TM 1-1500-335-23.

NOTE

A film density of 2.0 to 2.8 is mandatory across the area of interest. The penetrometer's outline (edges) and 2T hole must be visible on the radiograph to qualify the image. The edge of the tape used to attach the penetrometer may appear as a crack on the X-ray film.

(24) Interpret Exposures Number 1 and 2:

NOTE

Extreme care should be taken when drilling to remove rivets from vertical fin skin to insure spar assembly is not damaged.

(a) If a crack is indicated remove as many rivets as necessary, so that the skin may be pulled back and secured away from the spar in the area of crack indication. Repeat the radiograph of the spar with the skin removed.

(b) If a crack is still indicated, refer to paragraph 9 for corrective action. If a crack is not indicated, inspect the vertical tail fin skin for cracks. Repair skin cracks as allowable per TM 1-1500-204-23 and TM 55-1520-210-23-1.

(25) Interpret Exposure Number 3:

(a) Carefully examine exposure to assure that a single rivet is shown above the penetrometer and at least two rivets are shown below the penetrometer. At least 0.2 inches of film beyond the top of the single (countersunk) rivet located above the penetrometer must be visible on the X-ray to determine the status of the spar for this exposure. If the rivet is located under the angle support, which ties the left and right spar caps together aft of the 42 degree gearbox, it is possible that the entire rivet circumference will not be visible. In this situation, the radiograph must be retaken using the following method:

1 Carefully drill out the three most outboard rivets (left hand side) in the angle support. (See Figure 9A)

NOTE

Be careful not to permanently deform angle support or damage spar cap when attempting to insert X-ray film.

2 Carefully insert a plastic or phenolic wedge between the angle support and the left hand spar cap just enough to permit the X-ray film to slide up between the angle support and the spar cap. Attempt to slide the film as far as possible under the angle support so that it is visible through the hole in which the rivet had been removed.

3 Repeat Exposure #3 using the procedures of paragraph d. (16) through d. (23).

4 If at least 0.2 inches of film above the countersunk rivet is visible on the film, continue with interpretation and evaluation for cracks. If this criteria cannot be achieved, contact the technical POC in paragraph 16.a. of this TB for further instructions.

5 Removed rivets must be replaced by fasteners as directed in paragraph d. (27).

6 If all rivets are shown and a crack is indicated, refer to paragraph 9 for corrective action.

(26) If no cracks are found on all three exposures, re-attach the pulley assembly, tail rotor cable, and lockwire. Perform a tail rotor cable tension check and a tail rotor rigging check.

NOTE

A Maintenance Test Flight may be required if, during removal and installation of the tail rotor cable, the cable was adjusted from its previous position. If no adjustment was made it may only require a maintenance operational check. Refer to TM 1-1500-328-23.

(27) If the X-ray inspection required the removal of the three most outboard rivets attaching the angle support to the spar cap (reference figure 9A), and no cracks were found during this inspection, the rivets shall be replaced with the following fasteners: (NAS1303-5 or equivalent.)

NOTE

It is necessary to determine the rivet hole diameter in order to choose the appropriate size fastener to use. Several sizes are offered.

NOMENCLATURE	PART NUMBER	NATIONAL STOCK NUMBER
Machine screw, 10-32	NAS1801-3-10	5305-01-077-9906
Nut, Self-locking, 10-32	MS21042L-3	5310-00-807-1474
Washer, #10 flat	AN960C10L	5310-00-167-0812
Machine screw, 8-32	NAS1801-08-10	5305-01-102-8449
Nut, Self-locking, 8-32	MS21042L-08	5310-00-807-1473
Washer, #8 flat	AN960C8L	5310-01-352-9577
Machine screw, 6-32	NAS1801-06-10	5305-01-145-8346
Nut, Self-locking, 6-32	MS21042L-06	5310-00-807-1472
Washer, #6 flat	AN960C6L	5310-00-638-9857

NOTE

Maximum fastener hole diameter is 3/16 inch. Contact the Technical POC if this diameter is exceeded.

(a) Check rivet hole diameters. Recommend a #11 drill bit or the installation of NAS1303 fasteners. Torque to 25 in-lbs. Achieve a "class III" fit – objective is to be snug, yet removable. In some cases, the next over-size fastener may be required in order to meet the objective. In such cases, recommend a NAS2903-5, installed using a #6 drill bit (0.204) and torque to 25 in-lbs. A minimum edge distance of 1.5 times the hole diameter is required.

(b) Debur rivet hole and touch up bare metal with primer (TT-P-1757).

(c) Insert appropriate size bolts, with washers, from the top side of the spar into each of the two rivet holes. Using the lightening hole in the spar web for access, attach appropriate size nuts, with washers, from the underneath side of the spar.

(d) Due to the limited space beneath the spar web, it is necessary to torque the bolt head, in lieu of the nut. Standard torque valves shall be used.

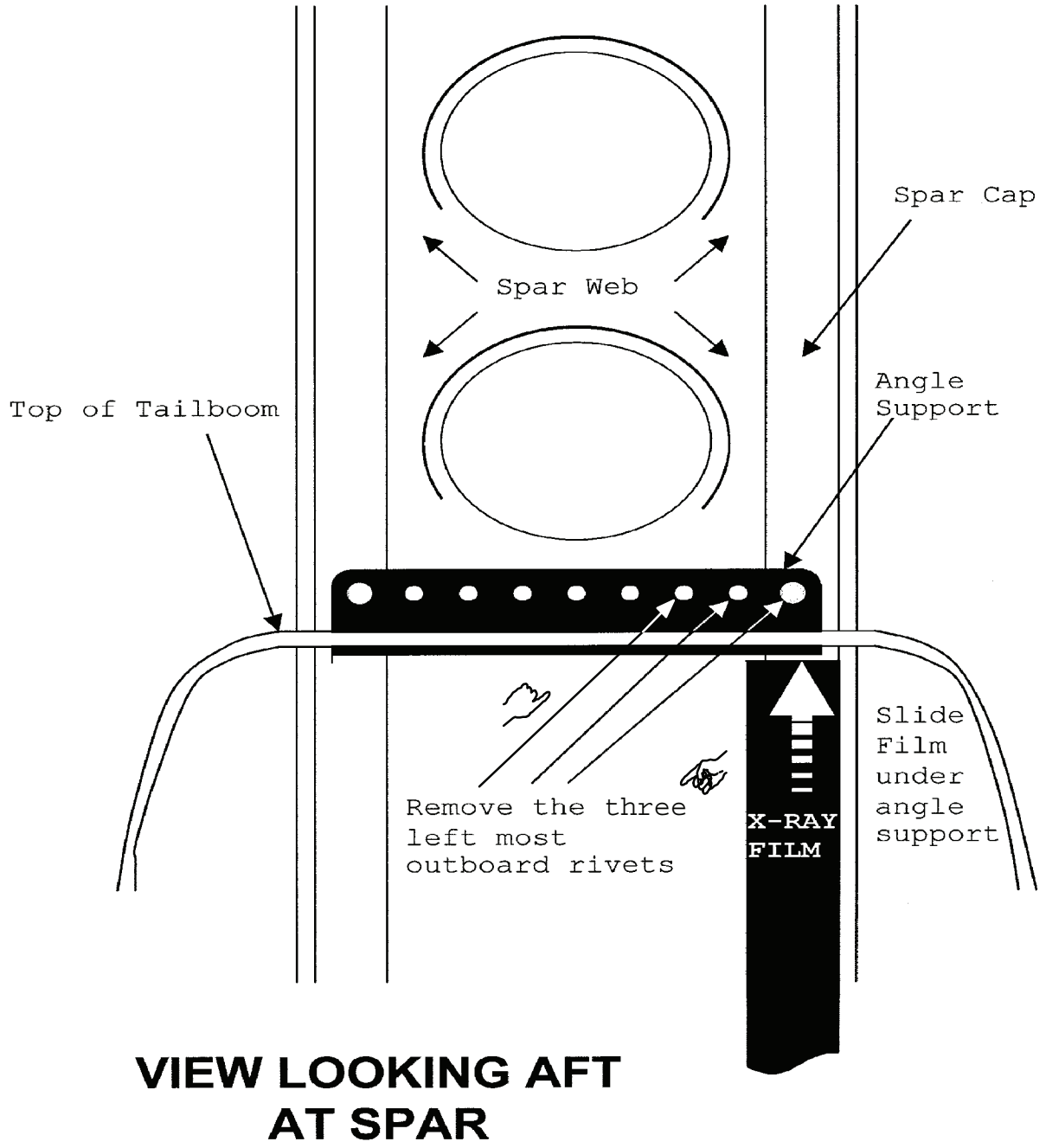

Figure 9A, Rivet Removal for Exposure #3

e. Tap Hammer Inspection:

NOTE

Inspect by lightly tapping on the surface of the spar. The number of taps per minute shall be such as to produce a continuous sound so that any differences in sound tone can be readily detected. The rate of tapping will vary, depending on the material and construction of the assembly. The force used in striking the surface will be to a degree that will not damage surfaces or finishes.

- (1) Use a tapping hammer that fits easily between the rivets.
- (2) Fin Spar Cap Inspection above Tail boom Interface:
 - (a) Locate left fin spar cap and doublers (bonded angles). (See Figure 1)
 - (b) Remove any surface contaminants with a cloth dampened with aliphatic naphtha (TT-N-95, Type 2, NSN 6810-00-238-8119). Thoroughly inspect edges of spar cap doublers visually for obvious debonding prior to performing tapping inspection.
 - (c) Start tapping operation between rivets on web flange of cap, at least three rivets away from end of the first doubler, to establish the "solid", "ringing" sound tone which will be very similar to a "good" adhesive bondline of the doublers. This also establishes the sound tone of the entire fin spar cap and fin assembly.
 - (d) Tap between successive spar rivets and onto first doubler edge and between doubler rivets.
 - (e) Sound tone of a debonded doubler will change significantly to a "dull," "dead," "hollow," or "rattle" sound.
 - (f) Continue tapping onto the second doubler between rivets. Repeat step 3 above for tone reference.
 - (g) Mark all areas with questionable sound tones for later evaluation by comparison with other well bonded areas.
 - (h) Repeat above operation on the inboard side of the left hand spar cap flange.
- (3) Fin Spar Cap Inspection below Tail boom Interface (Inside Tail boom):
 - (a) Repeat operations f.(2)(a) through (h) above.
 - (b) Accomplish tapping inspection as far up the spar cap as possible inside the tail boom.
- (4) All questionable sound tone areas shall be compared to similar areas on the other fin spar cap flanges for verification.
- (5) If debonding is found, evaluate and repair/replace components/assemblies as allowed per TM 55-1520-210-23-1.

f. Visual Inspection of Spar:

- (1) Remove any surface contaminants with a cloth dampened with aliphatic naphtha (TT-N-95, Type 2, NSN 6810-00-238-8119).

NOTE

A spar crack will be distinguishable by a hairline crack in the primer.

NOTE

Some removal of sealant may be necessary to properly inspect for cracks near the 90 degree gearbox mount.

(2) Using a flashlight, inspect the inboard side of the entire left hand spar cap flange above the tail boom interface for cracks. (See Figure 10) Cracks would usually emanate from a rivet hole and could also be visible on the edge of the spar cap flange doublers (nested angles). Pay particular attention for cracks emanating from the radius where the spar cap flange transitions and intersects the 90 degree gearbox mount. Use a 10x magnifying lens to inspect the following areas (See Figure 11):

NOTE

Some spars may have a doubler repair on the outboard side of the left hand spar cap flange near the 90 degree gearbox mount. This repair is authorized by TM 55-1520-210-23-1, paragraph 2-296.1, figure 2-73.1.

(a) The outboard side of the left hand spar cap flange, between the upper most Zeus fastener receptacle and the 90 degree gearbox mount. Pay particular attention for cracks emanating from the radius where the spar cap flange transitions and intersects the 90 degree gearbox mount. If a doubler repair is installed, or has been previously installed in this area, per TM 55-1520-210-23-1, paragraph 2-296.1, figure 2-73.1., visually inspect the underneath/aft side of the spar to detect crack growth using an inspection mirror through the uppermost lightening hole in the spar web.

(b) At the first ten rivets above the vertical fin to tail boom interface.

(3) If a crack is found, accomplish correction procedures of paragraph 9.

g. Upon completion of all inspections, reinstall inspection doors/panels, close the tail rotor driveshaft cover on the vertical fin, and reinstall the intermediate (42 degree) gearbox cover.

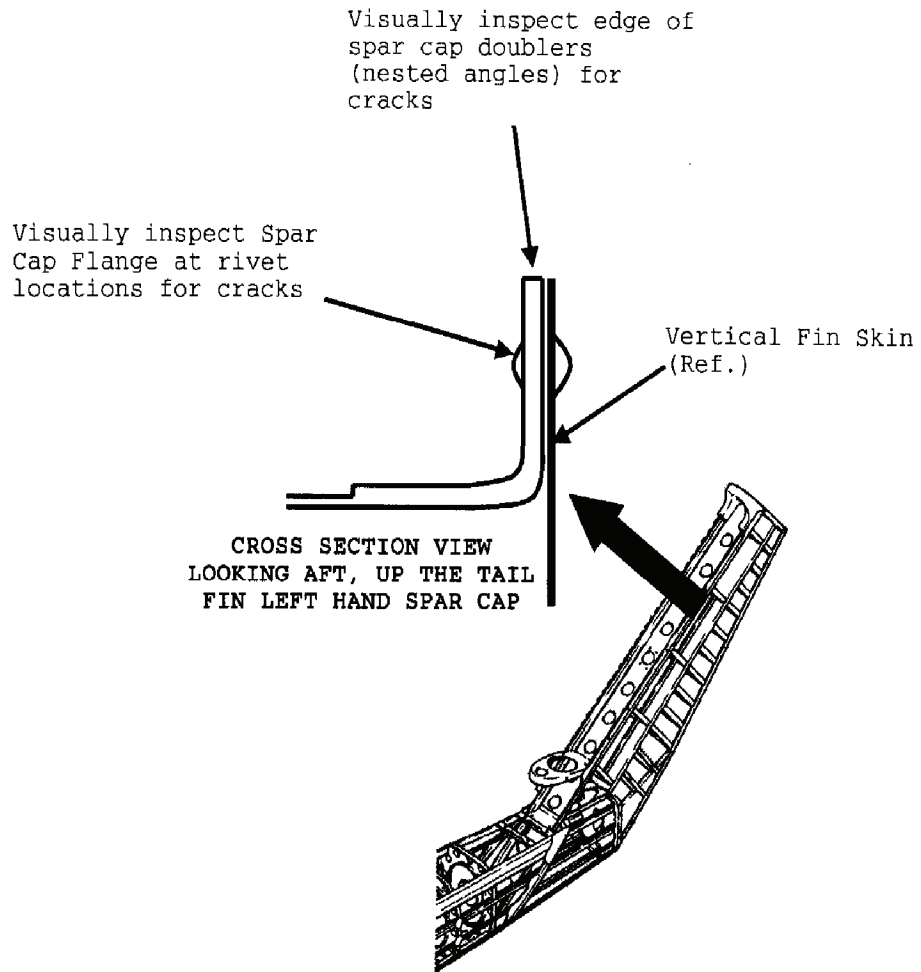

Gjhvsf 21; WjtvbmaJotqfdjpo pgTqbs

Jotqfdui f pvw pbse tjef pg
u f rfigi boe tqbs dbq
ghohf- cfux ffo u f vqqfs
n ptu[fvt gbtuf of s sfdf q.
ubdri boe u f : 1 efhsff
hfbscopy n pvoux ju 21y
n bhojzjoh rfiot/

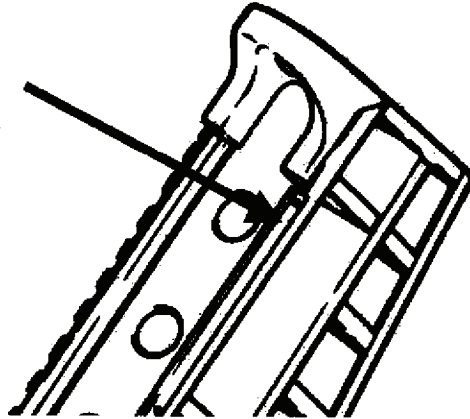

Jotqf dugstufo sjwfu
bcpwf ubjngjo Qbjmppn
jofsgbdf jo u jt bsfb
x ju 21y n bhojzjoh
rfiot/

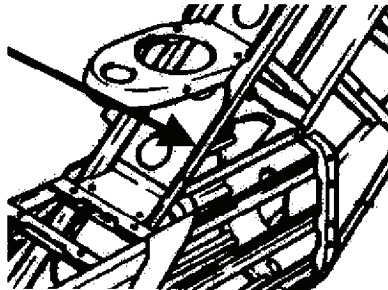

Figure 11: Visual Inspection of Spar.

9. Correction Procedures.

NOTE

Report results (both with cracks and with no cracks found) of the initial and recurring X-ray inspections to the logistical POC in paragraph 16.c. IAW paragraph 14.b.. This information is vital to ongoing efforts to extend the X-ray inspection interval.

a. If a crack is confirmed on the vertical fin spar assembly, determine the serviceability of the vertical fin spar assembly as follows:

(1) Cracks on the outboard side of the left hand spar cap flange between the upper most DZUS fastener receptacle and the 90 degree gearbox mount may be repaired using the criteria contained in TM 55-1520-210-23-1, paragraph 2-296.1, figure 2-73.1, however, the crack cannot exceed the repairable length limits specified in the TM.

(2) All other cracks, to include those on the outboard side of the left hand spar cap flange between the upper most DZUS fastener receptacle and the 90 degree gearbox mount that exceed the repairable length limit specified in TM 55-1520-210-23-1, paragraph 2-296.1, figure 2-73.1, shall not be repaired and the tailboom shall be considered discrepant.

NOTE

The requirement to submit X-ray film samples does not apply to FMS customers.

b. Units that have had their X-ray inspections performed by any entity other than an ARNG AVCRAD X-ray team, shall submit one set of X-ray film to AMCOM unless previously submitted and approved by the logistics POC listed in paragraph 16.b. Contact Mike Haragan, the logistical POC listed in paragraph 16.b., DSN 645-0211, (256) 955-0211, e-mail <mike.haragan@uh.redstone.army.mil>, for instructions on where to send one set of film from the most recent X-rays (to include exposures #1, #2, and #3) for review. Units need to include with submitted film; a point of contact with e-mail, phone/fax numbers and return address in order to receive a timely report of the results. Units shall identify the name of the organization/company performing the X-ray inspections. If units change the organization/company performing the X-ray inspection in the future, resubmittals shall be made within 15 days of the new inspection.

c. SOF UH-1-99-03, TB 1-1520-210-30-01, dated 9 Jun 99, described a typical crack as emanating from a rivet hole and propagating toward the edge of the spar cap in either direction. Reports have since been received that show cracks propagating from rivet holes in a variety of orientations. When examining the X-ray film or performing the visual inspection, attention should be paid to the entire circumference of each rivet hole for indications of cracks. Illustrations depicting typical spar crack orientation are available for viewing on the utility helicopters web page. The URL address is: www.uhpo.redstone.army.mil. Go to "safety", then "UH-1 Iroquois" information. Access to the web site is controlled. Procedures to obtain login ID are accessible by clicking the register button.

d. If no cracks are found during the initial inspection, the aircraft may be returned to fully mission capable status. Institute recurring inspections as directed in this TB using the inspection procedures in paragraph 8. Aircraft maintenance records shall retain the last five X-ray films documenting the results of these inspections.

e. If during the course of this inspection, other discrepancies (corrosion, debonding, etc.) are found, repair or replace component/assembly as allowable, IAW limits specified in TM 55-1520-210-23-1.

10. Supply/Parts and Disposition.

a. Parts Required. Tail boom cited in paragraph 6 may be required to replace defective items.

b. Requisitioning Instructions. Requisition replacement parts using normal supply procedures. All requisitions shall use project code (CC 57-59) "XFT".

NOTE

Project code "XFT", is required to track and establish a database of stock fund expenditures incurred by the field as a result of SOF actions.

c. Bulk and Consumable Materials. Reference paragraph 8.d.(2). Radiographic film, Kodak, 35MM x 200 ft., industrial X-ray, M speed redipack (cost: approximately \$150.00 plus S/H). Radiographic film can be purchased by contacting the Kodak government sales office at 1-800-828-6203. Credit card order and overnight shipment are available.

d. Disposition. Demilitarize/mutilate IAW TM 1-1500-328-23 any part/component which does not meet inspection criteria.

e. Disposition of Hazardous Material. IAW environmental protection agency directives as implemented by your servicing environmental coordinator (AR 200-1). Exposed film not maintained in historical records should be recycled for silver recovery.

11. Special Tools, Jigs and Fixtures Required. Reference paragraph 8.d.(2).

12. Application.

a. Category of Maintenance. **AVIM.** Aircraft downtime will be charged to **AVIM.**

b. Estimated Time Required.

(1) Total of 8 man-hour using 2 persons.

(2) Total of 4 hour downtime for one end item.

c. Estimated Cost Impact to the Field. \$50.00.

d. TB/MWOs to be Applied Prior to or Concurrently with this Inspection. (UH-1-00-07) TB 1-1520-210-20-47.

e. Publications Which Require Change as a Result of This Inspection. TM 55-1520-210-23-1, TM 1-1520-256-23, TM 55-1520-210-PM and DMWR 55-1560-222 shall be changed to reflect this TB. A copy of this TB shall be inserted in the appropriate TM as authority to implement the change until the printed change is received.

13. References.

a. TM 55-1520-210-23P-1.

b. TM 55-1520-210-23-1.

c. TM 55-1520-210-23-2.

d. TM 1-1520-256-23.

e. TM 1-1500-204-23.

f. TM 1-1500-328-23.

g. SOF UH-1-99-03 (TB 1-1520-210-30-01, Dated 9 Jun 99).

h. TB 1-1520-210-20-47 (UH-1-00-07).

14. Recording and Reporting Requirements.

a. **Reporting Compliance Suspense Date (Aircraft).** Upon entering requirements of the message/TB on DA Form 2408-13-1 on all subject MDS aircraft, forward a priority message, datafax or E-mail to CDR, AMCOM, ATTN: AMSAM-SF-A (SOF Compliance Officer), Redstone Arsenal, AL 35898-5000, IAW AR 95-1. Datafax number is DSN 897-2111 or commercial (256) 313-2111. E-Mail address is <safeadm@redstone.army.mil>. The report will cite the message/TB number, date of entry in DA Form 2408-13-1, the aircraft mission design series and serial numbers of aircraft in numerical order.

b. **Task/Inspection Reporting Suspense Date (Aircraft).** Units that have had their X-ray inspections performed by an outside entity (other than an AMCOM approved source) shall submit one set of X-ray film within 15 days of the DTG of the subject message IAW paragraph 9.b.

c. **Reporting Message/TB Receipt (Spares).** N/A.

d. **Task/Inspection Reporting Suspense Date (Spares At All Levels).** N/A.

e. **The following forms are applicable and are to be completed in accordance with DA PAM 738-751, 15 March 1999:**

NOTE

For ULLS-A users, use applicable "E" forms.

- (1) DA Form 2408-5-1, Equipment Modification Record (tail boom assembly).
- (2) DA Form 2408-13, Aircraft Status Information Record.
- (3) DA Form 2408-13-1, Aircraft Inspection and Maintenance Record.
- (4) DA Form 2408-15, Historical Record for Aircraft (include the serial number of the tail boom assembly that was inspected).
- (5) DA Form 2408-16, Aircraft Component Historical Record (only if the tail boom assembly is removed/or replaced).
- (6) DA Form 2408-18, Equipment Inspection List.
- (7) DA Form 2410, Component Removal and Repair/Overhaul Record (only if the tail boom assembly is removed/or replaced).
- (8) DD Form 1574/DD Form 1574-1, Serviceable Tag/Label - Materiel (color yellow). Annotate remarks block with "Inspected serviceable IAW SOF UH-1-99-03 (TB 1-1520-210-30-01)".
- (9) DD Form 1575/DD Form 1575-1, Suspended Tag/Label - Materiel (color brown). Annotate remarks block with "Suspended IAW SOF UH-1-99-03 (TB 1-1520-210-30-01)".
- (10) DD Form 1577-2/DD Form 1577-3, Unserviceable (Repairable) Tag/Label-Materiel (Color Green). (Annotate Remarks Block with "Unserviceable IAW UH-1-99-03, TB 1-1520-210-30-01").
- (11) DD Form 1577-1, Unserviceable (Condemn) Label-Materiel (Red).

15. **Weight and Balance.** N/A.

16. Points of Contact.

a. Technical point of contact for this TB are Mr. Darrell Hutson, AMSRD-AMR-AE-BG, DSN 897-2231 or (256) 313-2231. Fax is (256) 313-3195. E-mail is darrell.hutson@amrdec.redstone.army.mil. Alternate is Roger Redick (Westar), AMSRD-AMR-AE-BG, DSN897-2431 or (256) 313-2431. Fax is (256) 313-3195. E-mail is roger.redick@amrdec.redstone.army.mil.

b. Logistical point of contact for this TB are Mr. Howard Lee Reeves, SFAE-AV-AS-ASH-L, DSN 645-9701 or (256) 955-9701. Fax is 645-7125 or (256) 955-7125. E-mail is <howard.reeves@peoavn.redstone.army.mil>.

c. NDI inspection point of contact for this TB is Ms. Sandra Ratley, AMSAM-DSA-AS-AG, DSN 788-8043 or (256) 842-8043, datafax is DSN 788-0752 or (256) 842-0752. E-mail is <sandra.ratley@redstone.army.mil>.

d. Wholesale Materiel point of contact (Spares) is Mr. Kenneth Gardner, AMSAM-MMC-VS-UN, DSN 897-1545 or commercial (256) 313-1545, Datafax is DSN 897-1541 or (256) 313-1541. E-mail is <gardner-kd@exchange1.redstone.army.mil>.

e. Forms and records point of contact for this TB is Ms. Ann Waldeck, AMSAM-MMC-MA-NM, DSN 746-5564 or commercial (256) 876-5564. Datafax is DSN 746-4904 or (256) 876-4904. E-mail is <waldeck-ab@redstone.army.mil>.

f. Safety point of contact for this TB is Mr. Signey Hernandez, AMSAM-SF-A, DSN 897-2098 or commercial (256) 313-2098, Datafax is DSN 897-2111 or (256) 313-2111. E-mail is <signey.hernandez@redstone.army.mil>.

g. Foreign Military Sales (FMS) recipients requiring clarification of action advised by this TB should contact either CW5 Joseph L. Wittstrom, Security Assistance Management, AMSAM-SA, DSN 897-0410 or commercial (256) 313-0410; E-mail <wittstrom-jl@redstone.army.mil> or Mr. Ronnie W. Sammons, AMSAM-SA-CS-NF, DSN 897-0408 or (256) 313-0408; Datafax DSN 897-0411 or (256) 313-0411, E-mail <sammons-rw@redstone.army.mil> (Huntsville, AL. is GMT minus 6 hrs).

h. After hours contact AMCOM Command Operations Center (COC) DSN 897-2066/2067 or commercial (256) 313-2066/2067.

17. Reporting of Errors and Recommending Improvements. You can improve this TB. If you find any mistakes or if you know of a way to improve these procedures, please let us know. Mail your letter or DA Form 2028 (Recommended Changes to Publications and Blank Forms) directly to: Commander, US Army Aviation and Missile Command, ATTN: AMSAM-MMC-MA-NP, Redstone Arsenal, Alabama 35898-5000. A reply will be furnished to you. You may also send in your comments electronically to our E-mail address: 2028@redstone.army.mil or by datafax: DSN 788-6546 or commercial (256) 842-6546. Instructions for sending a 2028 by E-mail may be found at the back of most TMs.

By Order of the Secretary of the Army:

Official:

SANDRA R. RILEY
*Administrative Assistant to the
Secretary of the Army*
0525103

PETER J. SCHOOMAKER
*General, United States Army
Chief of Staff*

DISTRIBUTION:

To be distributed in accordance with the Initial Distribution Number (IDN) 313830, requirements for TB 1-1520-210-30-01.

PIN: 077358-000