**TECHNICAL MANUAL
OPERATORS, AVIATION UNIT.
AND AVIATION
INTERMEDIATE MAINTENANCE**

**BATTLEFIELD DAMAGE
ASSESSMENT AND REPAIR**



**FOR
HELICOPTER,
UTILITY,
UH-1H
(1520-00-087-7637)
AND
UH-1V
(1520-01-043-4949)**

CHAPTER 1 GENERAL INFORMATION	
CHAPTER 2 ASSESSING BATTLEFIELD DAMAGE	
CHAPTER 3 GENERAL REPAIRS	
CHAPTER 4 AIRFRAME	
CHAPTER 5 ALIGHTING GEAR	
CHAPTER 6 POWER PLANT INSTALLATION	
CHAPTER 7 ROTORS	
CHAPTER 8 DRIVE TRAIN SYSTEMS	
CHAPTER 9 HYDRAULIC & PNEUMATIC SYSTEMS	
CHAPTER 10 INSTRUMENTS	
CHAPTER 11 ELECTRICAL & AVIONICS SYSTEMS	
CHAPTER 12 FUEL SYSTEM	
CHAPTER 13 FLIGHT CONTROLS	
CHAPTER 14 UTILITY SYSTEM	
CHAPTER 15 ENVIRONMENTAL CONTROL SYSTEM (ECS)	
CHAPTER 16 HOIST & WINCHES	
CHAPTER 17 AUXILIARY POWER PLANT - N/A	
CHAPTER 18 MISSION EQUIPMENT	
APPENDIX A REFERENCES	
APPENDIX B SPECIAL TOOLS AND REPAIR KLTS	
APPENDIX C EXPENDABLE/DURABLE SUPPLIES & MATERIALS	
APPENDIX D SUBSTITUTE MATERIALS/PARTS	
APPENDIX E BDAR FIXES AUTHORIZED FOR TRAINING	
APPENDIX F AVIONICS CONFIGURATIONS	

CHANGE
NO. 1

HEADQUARTERS
DEPARTMENT OF THE ARMY
WASHINGTON, D.C., 02 September 1994

TECHNICAL MANUAL
OPERATOR'S, AVIATION UNIT, AND
AVIATION INTERMEDIATE MAINTENANCE
BATTLEFIELD DAMAGE ASSESSMENT AND REPAIR
FOR
HELICOPTER, UTILITY,
UH-1H (1520-00-084-7637) AND UH-1V (1520-01-043-4049)

DISTRIBUTION STATEMENT A: Approved for public release; distribution is unlimited

TM 55-1 5200-210-BD, 19 February 1991, is changed as follows:

1. Remove and insert pages as indicated below. New or changed text material is indicated by a vertical bar in the margin. An illustration change is indicated by a miniature pointing hand.

Remove pages

Insert pages

3-19 and 3-20

3-19 and 3-20

2. Retain this sheet in front of manual for reference purposes.

By Order of the Secretary of the Army:

Official:

MILTON H. HAMILTON
Administrative Assistant to the
Secretary of the Army
07653

GORDON R. SULLIVAN
General, United States Army
Chief of Staff

DISTRIBUTION:

To be distributed in accordance with DA Form 12-31-E, block no. 3068, requirements for TM 55-1520-210-BD.

WARNING AND PRECAUTIONARY DATA

Personnel performing operations, procedures, and practices which are included or implied in this technical manual shall observe the following warnings. Disregard of these warnings and precautionary information can cause serious injury or death.

The standards contained herein allow aircraft to be flown with battle damage substantially in excess of peacetime limits. Under no circumstances shall this manual be used wholly or in part for peacetime maintenance of the aircraft. Assessment of aircraft battlefield damage requires extreme care and diligence and strict adherence to the instructions and standards contained in this manual. If at any stage of damage assessment the assessor believes that oversights or errors have been made, the assessment shall be stopped at that point and repeated from the beginning. Under no circumstances shall the requirements of this manual be waived or circumvented without the express approval of the commander or his designated representative.

WARNINGS

Battle damaged areas should be inspected for unexploded ordnance before attempting repairs. Disposal of unexploded ordnance should be accomplished by qualified EOD personnel.

Substitute or repair hoses must meet system pressure and fluid requirements.

Adhesives and materials must be compatible with the system fluid.

AIRCRAFT FIRE EXTINGUISHER

Exposure to high concentrations of fire extinguishing agent or decomposition products should be avoided. The liquid should not be allowed to come into contact with the skin, as it may cause frost bite or low temperature burns.

ARMAMENT

Loaded weapons, or weapons being loaded or unloaded, shall be pointed in a direction which offers the least exposure to personnel or property in the event of accidental firing. Personnel shall remain clear of hazardous area of all loaded weapons.

CLEANING SOLVENTS

Cleaning solvents may be flammable and toxic. Use only in well-ventilated areas. Avoid inhalation of vapor and skin contact. Do not use solvents near open flame or in areas where very high temperatures prevail. Solvent flash point must not be less than 100°F.

ELECTROLYTE

Battery Electrolyte (Potassium Hydroxide) is corrosive. Wear rubber gloves, apron, and eye protection when handling leaking batteries. If potassium hydroxide is spilled on clothing or other material, wash immediately with clean water. If spilled on personnel, immediately start flushing the affected area with clean water. Continue washing until medical assistance arrives.

TOXIC POISONS

Turbine fuels and lubricating oils contain additives which are poisonous and readily absorbed through the skin. Do not allow them to remain on skin longer than necessary.



RADIOACTIVE MATERIALS

Self-luminous dials and ignition units may contain radioactive materials. If such an instrument or unit is broken or becomes unsealed, avoid personal contact. Use forceps or gloves made of rubber or polyethylene to pick up contaminated material. Place materials and gloves in a plastic bag. Seal bag and dispose of it as radioactive waste in accordance with AR 755-15 and TM 3-261 (refer to TB 43-0108). Repair shall conform to requirements in AR 700-52.

CAUTION

Dynamic components which have experienced sudden stoppage, overtemperature, over-torque, or overspeed shall be evaluated prior to reuse.

LIST OF EFFECTIVE PAGES

Insert latest changed pages; dispose of superseded pages in accordance with applicable regulations.

NOTE: On a changed page, the portion of the text affected by the latest change is indicated by a vertical line or other symbol in the outer margin of the page. Changes to illustrations are indicated by miniature pointing hands. Changes to wiring diagrams are indicated by shaded areas.

Dates of issue for original and changed pages are:

Original 19 February 1991

Page No.	*Change No.
Cover.	0
a thru b	0
A/(B Blank)	0
i thru viii	0
1-1 thru 1-9/(1-10 Blank)	0
2-1 thru 2-8	0
3-1 thru 3-21/(3-22 Blank)	0
4-1 thru 4-84	0
5-1 thru 5-7/(5-8 Blank)	0
6-1 thru 6-9/(6-10 Blank)	0
7-1 thru 7-4	0
8-1 thru 8-19/(8-20 Blank)	0
9-1 thru 9-25/(9-26 Blank)	0
10-1 thru 10-7/(10-8 Blank)	0
11-1 thru 11-39/(11-40 Blank)	0
12-1 thru 12-23/(12-24 Blank)	0
13-1 thru 13-30	0
14-1/(14-2 Blank)	0
15-1/(15-2 Blank)	0
16-1/(16-2 Blank)	0
17-1/(17-2 Blank)	0
18-1/(18-2 Blank)	0
A-1 thru A-2	0
B-1 thru B-9/(B-10 Blank)	0
C-1 thru C-9/(C-10 Blank)	0
D-1 thru D-22.	0
E-1 thru E-2	0
F-1 thru F-37/(F-38 Blank)	0
GLOS-1 thru GLOS-8.	0
INDEX-1 thru INDEX-4.	0

*Zero in this column indicates an original page.

Technical Manual

HEADQUARTERS
DEPARTMENT OF THE ARMY
WASHINGTON, D.C., 19 February 1991

No. 55-1520-210-BD

**TECHNICAL MANUAL
OPERATORS, AVIATION UNIT, AND AVIATION INTERMEDIATE MAINTENANCE
BATTLEFIELD DAMAGE ASSESSMENT AND REPAIR FOR
HELICOPTER, UTILITY, UH-1H (1520-00-087-7637) AND
UH-1V (1520-01-043-4949)**

REPORTING ERRORS AND RECOMMENDING IMPROVEMENTS
You can help improve this manual. If you find any mistake or if you know of a way to improve the procedure, please let us know. Mail your letter or DA Form 2028 (Recommended Changes to Publications and Blank Forms) direct to: Commander, U.S. Army Aviation Systems Command, ATTN: AMSAV-MC, 4300 Goodfellow Blvd., St. Louis, MO 63120-1798. A reply will be furnished to you.

TABLE OF CONTENTS

	Page
HOW TO USE THIS MANUAL	vi i
 CHAPTER 1 - GENERAL INFORMATION	
Section I. Introduction	1-1
Section II. Standards and Practices	1-4
Section III. Tasks and Responsibilities	1-5
 CHAPTER 2- ASSESSING BATTLEFIELD DAMAGE	
Section I. Introduction	2-1
Section II. Fault Assessment	2-1
 CHAPTER 3- GENERAL REPAIRS	
Section I. Introduction	3-1
Section II. Skin Structure	3-1
Section III. Stiffener and Stringers	3-2
Section IV. Longerons and Caps	3-6
Section V. Bulkhead and Former Frames	3-7
Section VI. Honeycomb Panel	3-16
Section VII. Low Pressure Hoses and Metal Tubing	3-20
 CHAPTER 4- AIRFRAME	
Section I. Introduction	4-1
Section II. Airframes	4-25
Section III. Nose Section	4-83

TABLE OF CONTENTS (Cont)

	Page
CHAPTER 5 - ALIGHTING GEAR	
Section I. Introduction	5-1
Section II. Skid Tube	5-3
CHAPTER 6 - POWER PLANT INSTALLATION	
Section I. Introduction.	6-1
Section II. Oil Tank.	6-1
Section III. Accessory Gearbox and Fuel Control Assembly.	6-7
CHAPTER 7 - ROTORS	
Section I. Introduction.	7-1
Section II. Main Rotor Blades.	7-1
CHAPTER 8 - DRIVE TRAIN SYSTEMS	
Section I. Introduction.	8-1
Section II. Main Transmission Assembly	8-1
Section III. Tail Rotor Driveshaft Assembly	8-10
Section IV. Intermediate Gearboxes	8-17
CHAPTER 9 - HYDRAULIC AND PNEUMATIC SYSTEMS	
Section I. Introduction	9-1
Section II. Hydraulic Reservoir.	9-7
Section III. Hydraulic Filter.	9-9
Section IV. Relief Valve.	9-10
Section V. Solenoid Valve.	9-12
Section VI. Pressure Switch	9-14
Section VII. Check Valves	9-14
Section VIII. Armament Hydraulic System	9-16
Section IX. Hydraulic High Pressure Hoses.	9-16
Section X. Hydraulic High Pressure Metal Tubing	9-16
Section XI. Bleed Air System Tubes and Hoses	9-18
Section XII. Bleed Air Fitting.	9-24
CHAPTER 10- INSTRUMENTS	
Section I. Introduction	10-1
Section II. Assessment and Repair Planning	10-1
Section III. Engine Oil Pressure Indicator and Transmitter.	10-4
Section IV. Pitot/Static System.	10-6

TABLE OF CONTENTS (Cont)

	Page
CHAPTER 11- ELECTRICAL AND AVIONICS SYSTEMS	
Section I. Introduction	11-1
Section II. Wire and Cable	11-7
Section III. Connector Repair	11-23
Section IV. Circuit Overcurrent Protection Devices	11-25
Section V. Bus Bars	11-29
Section VI. Power Relays	11-32
Section VII. Antennas	11-35
CHAPTER 12- FUEL SYSTEM	
Section I. Introduction	12-1
Section II. Fuel Lines	12-5
Section III. Fuel Cells	12-12
CHAPTER 13- FLIGHT CONTROLS	
Section I. Introduction	13-1
Section II. Connecting Links	13-1
Section III. Lever Assemblies	13-22
Section IV. Bellcranks	13-23
Section V. Elevator	13-23
Section VI. Control Cables	13-27
CHAPTER 14- UTILITY SYSTEM	14-1
CHAPTER 15- ENVIRONMENTAL CONTROL SYSTEM (ECS)	15-1
CHAPTER 16- HOIST AND WINCHES	16-1
CHAPTER 17- AUXILIARY POWER PLANT	17-1
CHAPTER 18- MISSION EQUIPMENT	18-1
APPENDIX A - REFERENCES	A-1
APPENDIX B - SPECIAL TOOLS AND REPAIR KITS	B-1
APPENDIX C - EXPENDABLE/DURABLE SUPPLIES AND MATERIALS LIST.	C-1
APPENDIX D - SUBSTITUTE MATERIALS/PARTS.	D-1
APPENDIX E - BDAR FIXES AUTHORIZED FOR TRAINING.	E-1
APPENDIX F - AVIONICS CONFIGURATIONS	F-1
GLOSSARY	GLOS-1
INDEX	INDEX-1

LIST OF ILLUSTRATIONS

Figure	Title	Page
3-1	External Stiffener/Stringer Patch.	3-4
3-2	Patch Plate Repair.	3-5
3-3	Expedient Longeron/Cap Repair.	3-8
3-4	Bulhead and Former Damage.	3-9
3-5	Typical Bulhead and Former Repair (Sheet 1 of 2).	3-10
3-6	Repair of Damaged Bulhead Flange (Sheet 1 of 2)	3-14
3-7	Honeycomb Panel Repair.	3-18
3-8	Repair of Honeycomb Core Panel - Damage up to 12 X 12 Inches - Both Skins and Core	3-19
4-1	Fuselage Structure, Station, Water, and Butt Lines (Sheet 1 of 15)	4-2
4-2	Forward Fuselage Skin (Sheet 1 of 6)	4-17
4-3	Damage Limits Measurement for Tables 4-1 thru 4-10	4-26
5-1	Landing Gear and Support Installation.	5-2
5-2	Skid Tube Damage Inspection.	5-5
5-3	Skid Tube Splint Repair.	5-6
5-4	Skid Tube - Splint and Clamp Repair.	5-7
6-1	Oil Tank.	6-3
6-2	Screw, Washer, and Gasket	6-4
6-3	Sheet Metal with Sealant or Blind Rivets	6-6
6-4	Fuel Control and Accessory Gearbox Assemblies.	6-8
6-5	Tach Generator Removal	6-9
7-1	Blade Repair by Application of Tape.	7-4
8-1	Drive Train System, Major Components (Sheet 1 of 2).	8-4
8-2	Pressure Switch and Transmitter.	8-7
8-3	Transmission External Oil Filter Bypass.	8-9
8-4	Damage Passing Through Center of Shaft	8-12
8-5	Balance Restoring Repair for Damage Not Passing Through the Center of Shaft	8-13
8-6	Y vs. S	8-15
8-7	Area vs. Diameter.	8-15
8-8	Repaired Shaft.	8-16
8-9	Shaft Area (in ²) vs. Number of Rivets.	8-18
9-1	Hydraulic System (Sheet 1 of 2).	9-3
9-2	Hydraulic System Schematic (Gravity Feed) (Sheet 1 of 2)	9-5
9-3	Patch Repair for Leaks	9-8
9-4	Filter Bypass Hose Installation.	9-10
9-5	Relief Valve, Removal	9-11
9-6	Solenoid Valve Replacement	9-13
9-7	Bypass of Solenoid Valve	9-13
9-8	Check Valve Substitution.	9-15
9-9	Rubber Pressure Patch	9-17
9-10	UH-1 Bleed Air System.	9-19
9-11	Bleed Air Hose Repair.	9-20
9-12	Rigid Bleed Air Tube Splice Repair	9-22
9-13	Rigid Bleed Air Tube Patch Repair.	9-23
9-14	Bypassing Damaged Bleed Air Fittings	9-25
10-1	Oil Pressure Transmitter	10-5
10-2	Bypassing Damaged Plenum	10-7

LIST OF ILLUSTRATIONS (Cont)

Figure	Title	Page
11-1	Circuit Identification	11-2
11-2	Splicing with Terminal Lug Barrel	11-8
11-3	Twist Wire Splice	11-10
11-4	Replacement Section; Twist Wire Splice	11-10
11-5	Metal Casting Splice Repair	11-11
11-6	Bolted Terminal Lug Repair of Large Wires	11-12
11-7	Replacement Section; Terminal Lug Repair	11-12
11-8	Ram Wire Repair	11-13
11-9	Insulation Repair with Sleeving	11-15
11-10	Shielded Cable Repair Preparation	11-17
11-11	Pigtail Method Repair	11-18
11-12	Substitute Shielded Braid Repair	11-19
11-13	Component Bypass	11-23
11-14	Connector Pin and Socket	11-24
11-15	Damaged Connector and Pigtail	11-25
11-16	Construction of Fuse Link	11-27
11-17	Fabricated Fuse, Type A	11-28
11-18	Fabricated Fuse, Type B	11-29
11-19	Splicing Bus Bars	11-30
11-20	Lengthening Bus Bars	11-30
11-21	Battery, Storage BB-433/A Cell Layout	11-32
11-22	UH-1H/V Relay Location (Sheet 1 of 4)	11-34
11-23	Block Diagram, Typical Power Relays	11-34
11-24	Frequency vs. Wave Length	11-36
11-25	Fabrication of Emergency Antenna	11-36
11-26	Installation of Field Expedient Antenna	11-37
11-27	Pigtail Termination for Shielded Wire	11-38
12-1	Fuel Cell Installation - Crashworthy	12-2
12-2	Fuel System Schematic	12-3
12-3	Fuel System Hose/Tube Installation (Sheet 1 of 4)	12-6
12-4	Hose and Clamp Fuel Tubing Repair	12-10
12-5	Damaged Hose Repair	12-11
12-6	Fuel Cell Location and Approximate Arm as Compared with Center of Gravity	12-13
12-7	Isolation of Cell A	12-15
12-8	Isolation of Cell B	12-16
12-9	Isolation of Cell D or E	12-18
12-10	Inlet Line to Fuel Control	12-19
12-11	Emergency Mechanical Clamp Repair	12-21
12-12	Fuel Cell Patch Repair	12-22
12-13	Filter Bypass Detail	12-23
13-1	Cyclic Control System	13-2
13-2	Collective Control System	13-3
13-3	Elevator Control System	13-4
13-4	Power Control System	13-5
13-5	Tail Rotor Control System	13-6
13-6	Control Connecting Link Splices	13-13
13-7	Fabrication of Link End (Sheet 1 of 2)	13-14
13-8	Fabrication of Links from Tube	13-17

LIST OF ILLUSTRATIONS (Cont)

Figure	Title	Page
13-9	Fabrication of Connecting Link (Sheet 1 of 3)	13-19
13-10	Fabrication of Lever from Flat Bar Stock	13-22
13-11	Fabrication of Bellcranks and Levers (Sheet 1 of 2)	13-24
13-12	Elevator Lock nut	13-26
13-13	Clamp Splicing Control Cable (Sheet 1 of 2)	13-29

LIST OF TABLES

Table No.	Title	Page
1-1	Damage Assessment Markings	1-6
2-1	General Decision Logic	2-2
2-2	Helicopter Flight Assessment	2-3
4-1	Damage Limits Cabin Roof - Condition I	4-27
4-2	Damage Limits Fuselage, Forward (FS 23 to 129) - Condition I	4-32
4-3	Damage Limits Fuselage, Midsection (FS 129 to 178) - Condition I	4-38
4-4	Damage Limits Fuselage, Aft (FS 178 to 243)- Condition I	4-44
4-5	Damage Limits Tail Boom - Condition I	4-47
4-6	Damage Limits Cabin Roof - Condition II	4-55
4-7	Damage Limits Fuselage, Forward (FS 23 to 129) - Condition II	4-59
4-8	Damage Limits Fuselage, Midsection (FS 129 to 178) - Condition II	4-65
4-9	Damage Limits Fuselage, Aft (FS 178 to 243) - Condition II	4-72
4-10	Damage Limits Tail Boom - Condition II	4-75
5-1	Assessment Procedures	5-3
6-1	Assessment Procedures	6-2
7-1	Assessment Procedures.	7-2
8-1	Assessment Procedures.	8-2
8-2	Shaft Area (in ²) vs. Number of Rivets.	8-18
9-1	Assessment Procedures.	9-2
10-1	Instruments Assessment	10-2
10-2	System Evaluation.	10-3
10-3	Functional List and Flight Essential Instruments	10-5
11-1	Function and Designation Letters	11-2
11-2	Electrical and Avionics System Assessment.	11-5
11-3	Fuse Link.	11-26
12-1	Assessment Procedures	12-4
12-2	Weight & Balance Computation Data for Fuel Cells	12-13
13-1	Assessment Procedures	13-7
13-2	Connecting Link Dimensions	13-10
13-3	Bolt/Drill Sizes for Splice Repairs.	13-12
13-4	Fabricated Link End Dimensions	13-16

HOW TO USE THIS MANUAL

This manual is developed to assist the soldier in a battlefield environment make assessment and repair of damage to the UH-1H/V utility helicopter which cannot, due to asset availability or environmental factors, be repaired in the normal prescribed manner. Within this technical manual, the word shall is used to indicate a mandatory requirement. The word should is used to indicate a nonmandatory but preferred method of accomplishment. The word may is used to indicate an acceptable method of accomplishment.

1. Organization of the Manual. This manual contains a general information chapter (chapter 1), a general assessment chapter (chapter 2), a general repair chapter (chapter 3), and specific repair chapters (chapters 4 thru 18). It also contains five appendixes, A through F.

2. Chapter 2 is used to assess the helicopter in general and references specific chapters for detailed repair procedures of the major functional groups. The major functional groups correspond with the functional groups of the -23 series manuals that are employed in routine repairs to the helicopter.

3. Chapter 3 contains repairs for equipment which does not fall under one of the standard helicopter functional groups.

4. Each chapter is organized as follows:

a. Section I - Introduction.

- (1) Scope. Purpose of the chapter.
- (2) Assessment Procedures. General assessment information for the repairs covered therein.
- (3) Repair Procedure Index.

b. Section II - Repair Item. A subsection is included for each repair item covered in that functional group. It contains the following:

- (1) General. About the nature and cause of damage and repair.
- (2) Item and trouble statement with:
 - (a) Limits given.
 - (b) Personnel and time required to effect repairs.
 - (c) Materials and tools needed.
 - (d) Procedural steps to accomplish the repair.
- (3) If more than one method of repair can be used, the various options will be included next.

NOTE

The first option is the preferred choice, the second option is the next preferred, etc. Selection of the option should be the most preferred method possible under the circumstances and with the available materials and manpower.

HOW TO USE THIS MANUAL (Cont)

5. Finding Repairs in this Manual.

a. When the damage is obvious and known, find the functional group chapter of which the damaged item is a part. Turn to the repair procedure index, section I, subparagraph 3, of each chapter to locate the item being repaired. Then turn to the repair section and review each option to find an appropriate fix. Read the entire section for all the options. Select a repair and follow the procedures given to fix the helicopter.

b. When the damage is hidden or unknown, follow the overall assessment procedures provided in chapter 2, and follow the procedures and directions provided.

6. Preparation.

a. Each mechanic/technician shall have read chapters 1 and 2 and become familiar with the repairs and layout of the manual prior to attempting to accomplish BDAR repairs.

b. All warnings, cautions, and safety precautions shall be followed at all times during BDAR procedures so as not to further damage and/or jeopardize either personnel or the equipment during or subsequent to the BDAR action. Ensure all documentation is completed as directed in this manual and by local command.

7. Expendable/Durable Supplies and Materials.

a. Each fix or repair option contains a short listing of materials and tools considered basic to the repair. It is important to note that the expendable materials listed usually cover a wide range for any one item.

Example: **MATERIALS/TOOLS REQUIRED:**

- Drill with Bit
- Sheet Metal (Items 129-141, App C)
- Rivets (items 94-114, App C)

In this example, sheet metal covers the range of items 129 thru 141 listed in Appendix C. This means that, depending on the circumstances and location of the fix, any one of these metals could be used. Likewise any one of the rivets, items 94 thru 114, may be used to attach the patch plate depending on the application.

b. One of the key points concerning successful BDAR repairs is flexibility. The users of this manual should strive to use the items on hand, provided a safe repair is made. The stringent requirements of normal maintenance may be lifted.

CHAPTER 1

GENERAL INFORMATION

BDAR FIXES SHALL BE USED ONLY IN COMBAT OR FOR TRAINING
AT THE DISCRETION OF THE COMMANDER.
(AUTHORIZED TRAINING FIXES ARE LISTED IN APPENDIX E.)
IN EITHER CASE, DAMAGES SHALL BE REPAIRED BY STANDARD
PROCEDURES AS SOON AS PRACTICABLE.

Section I. INTRODUCTION

1-1. **PURPOSE.** The purpose of Battlefield Damage Assessment and Repair (BDAR) is to quickly return the disabled helicopter to duty by expeditiously fixing, bypassing, or jury-rigging components to restore the minimum essential systems required for the support of the specific combat mission, or self-recovery. These repairs will be temporary and may not restore full performance capability. Standard repair will be completed as soon as practicable.

1-2. **SCOPE.**

a. This technical manual (TM) describes BDAR procedures and fixes applicable to UH-1 utility helicopter. These procedures are to be used by crew, operators, aviation unit maintenance (AVUM) teams, and aviation intermediate maintenance (AVIM) support teams.

b. Standard repair techniques for the UH-1 helicopter are included in other technical manuals which are referenced in Appendix A of this TM. If the repairs are more than one page in length, the repairs may only be referenced to the appropriate TM.

c. All possible types of combat damage and failure cannot be predicted, nor are all effective field expedient repairs known. This TM provides guide-

lines for assessing and repairing battlefield failures of UH-1 helicopters and is not intended to be a complete catalog of all possible emergency repairs. The repairs described here will serve as guidelines and will stimulate the experienced mechanic or operator to devise repairs as needed to quickly return equipment to operation in a combat situation.

d. The direct replacement of a piece of equipment by its spare, even under battlefield conditions, is not a BDAR fix and is not covered in this TM. A standard procedure should be performed in preference to a BDAR fix when time and spares are available.

1-3. **APPLICATION.**

a. The procedures in this manual are designed for battlefield environments. BOAR procedures are only authorized for use in a battlefield environment, and only at the direction of the commander. These fixes are only temporary and are not to be continued after the equipment is out of the battle environment.

b. BDAR techniques are not limited to simple restoration of minimum functional combat capability. If full functional capability can be restored expeditiously with a limited expenditure of time and assets, it should be accomplished.

c. Some of the special techniques in this manual, if applied, may result in shortened life or in further damage to major components of the helicopter. The commander must decide whether the risk of having one less helicopter available for combat outweighs the risk of applying the potentially destructive expedient repair technique. Each technique gives appropriate warnings, cautions, and lists systems limitations caused by this action.

1-4. DEFINITIONS.

a. Battlefield Damage. Any incident such as combat damage, random failures, operator errors, accidents, and wear out failures which occur on the battlefield and which prevent the helicopter from accomplishing its mission.

b. Repair or Fix. Any expedient action that returns a damaged part or assembly to a full or an acceptably degraded operating condition, including:

(1) Short cuts in parts removal or installation.

(2) Installation of components from other equipment that can be modified to fit or interchange with components on the damaged equipment.

(3) Repair using parts that serve a noncritical function elsewhere on the same equipment for the purpose of restoring a critical function.

(4) Bypassing of noncritical components in order to restore basic functional capability.

(5) Expedient cannibalization procedures.

(6) Fabrication of parts from kits or readily available materials.

(7) Jury-rigging.

(8) Use of substitute materials.

c. Damage Assessment. A procedure to rapidly determine what is damaged, whether it is repairable, what assets are required to make the repair, who can do the repair (e.g., crew, maintenance team or maintenance support team), and where the repair should be made. The assessment procedure includes the following steps:

(1) Determine which components must be fixed.

(2) Determine if the repair can be deferred, or if it must be done.

(3) Determine if isolating and/or bypassing can be done to damaged areas and components.

(4) Select and prescribes fix.

(5) Determine if parts or components, materials, and tools are available for selected fix.

(6) Estimate the manpower and skill required.

(7) Estimate the total time (clock hours) required to make the repair.

(8) If more than one damage exists, establish the priority of the fix.

(9) Decide where the fix shall be performed.

(10) Decide if recovery or evacuation is necessary and to what location.

d. Fully Mission Capable (FMC). The helicopter can perform all its combat missions. To be FMC, the helicopter must be complete and fully operable with no faults listed in the aircraft inspection and maintenance record as prescribed in DA PAM 738-751.

e. Combat Capable. Equipment meets the minimum functional combat capability requirements. (See paragraph 1-7.)

f. Combat Emergency Capable. The equipment meets the needs for specific tactical missions; however, all systems are not functional. Also, additional damage due to the nature of an expedient repair may occur to the equipment if it is used. The commander must decide if these limitations are acceptable for that specific emergency situation.

g. Cannibalization or Controlled Exchange. Throughout this manual, cannibalization and-controlled exchange are used interchangeably meaning the removal of an item of materiel from one piece of equipment for immediate use in another. Generally, the rules for cannibalization/controlled exchange provided in TM 1-1500-328-25, as modified by local authority, will prevail.

h. Evacuation. A combat service support function which involves the movement of recovered helicopters from a main supply route, maintenance collection point, or maintenance activity to higher categories of maintenance. The materiel may be returned to the user, to the supply system for reissue, or to property disposal activities.

i. Recovery. The retrieval of immobile, inoperative, or abandoned helicopter from the battlefield or immediate vicinity, and its movement to a maintenance collection point, the main supply route, or a maintenance activity for disposition, repair, or evacuation.

j. Self-Recovery. The ability of a battle damaged helicopter to retrieve itself (fly-out) from a battlefield environment. It usually will involve flying with degraded aircraft status and with restrictions and limitations placed on performance characteristics such as limitations placed on weight, airspeed, engine torque, and other characteristics. In BDAR repairs, the limitations recommended should be followed. Emergency flight procedure in TM 55-1520-210-10 should further be consulted.

k. Maintenance Collection Point. A point operated by AVIM unit for the collection of equipment for repair.

l. Maintenance Support Team (MST). A team of AVIM mechanics and technical specialists who are trained in assessing battlefield damage and field repair procedures.

m. Maintenance Team (MT). Helicopter crew chief or AVUM mechanics/technicians who are trained in assessing battlefield damage and field repair procedures.

Section II. STANDARDS AND PRACTICES

1-5. **BDAR CHARACTERISTICS.** BDAR capability requires simplicity, speed, and effectiveness. Some BDAR procedures include repair techniques that violate standard peacetime maintenance practices. In a combat emergency situation, greater risks are sometimes necessary and acceptable.

1-6. **WAIVER OF PRECAUTIONS.** Under combat conditions, BDAR may be performed on helicopters which are in flight or which are under power while on the ground. While some of these BDAR actions may require waiving of safety precautions, the cautions to protect personnel life should not be overlooked. Other similar precautions may be waived at the discretion of the commander. BDAR fixes may be required in a Nuclear Biological Chemical (NBC) environment or under other adverse battlefield conditions with severe limitations in personnel, facilities, equipment, and materials. Performance of repair tasks may be necessary while wearing protective gear. In the case of NBC environment, decontamination procedures are described in FM 3-5, NBC Decontamination.

1-7. **OPERATING CHARACTERISTICS.** This manual covers expedient repairs for the UH-1 helicopter and its components. It is entirely possible that in a combat situation the helicopter, having undergone one or more repairs, may suffer degradation of its normal operating characteristics (e.g., reduced speed, reduced load capability, reduced range, etc.), and still be able to carry out all or parts of an assigned mission. The minimum functional combat capability (MFCC) criteria for the UH-1 areas follows:

WARNING

Careful consideration shall be given to the operation of the Identify Friend or Foe (IFF), Mode 4, avionics system. Failure of the IFF or failure to properly communicate with area air defense command prior to liftoff could result in an attack from friendly forces due to mistaken identity.

NOTE

Criteria may be waived for recovery or if the tactical situation demands otherwise.

a. Flight Capability for Mission Completion. Helicopter's flight characteristics degraded to a minimum of combat capable (CC).

(1) Sufficient power for safe flight for intended mission capability for helicopter crew and cargo.

(2) No fuel leaks which will curtail the intended length of flight.

(3) No degradation of any component/system which will end in failure and curtailment of intended mission.

(4) Communications. Must have intercom communications within aircraft and at least two tactical receiver-transmitter (R-T) units operating at full capability.

b. Flight Capability for Self-Recovery Capability (SRC).

(1) Must have power torque delivered to the main rotor and tail rotot at acceptable limits.

(2) Lift capability for a minimum size crew. Unload unnecessary weight (cargo). Dump excess fuel if necessary.

(3) Flight controls at minimum function level acceptable for flight.

(4) Maximum speed of 50 kts.

(5) Maximum flight duration of 1/2 hours. Consideration will be given to minimize flight duration and inspection of damage or nonfunctional area causing downgrading of flight status.

(6) Be prepared for emergency landing procedures. See TM 55-1520-210-10.

(7) Instruments/avionics as required to meet needs.

1-8. TRAINING.

a. BDAR by its nature involves fixes, bypasses, and/or jury-rigging which is outside authorized standard repairs, and may degrade the inherent safety of the helicopter. BDAR actions are not intended to supplement or replace standard maintenance practices during peacetime. They should not be employed indiscriminately to facilitate training.

b. BDAR fixes authorized for sustainment training are listed in Appendix E. In addition, repair procedures which are authorized for training will be boxed in the chapter repair procedures index.

Section III. TASKS AND RESPONSIBILITIES

1-9. TAGGING/IDENTIFYING BDAR REPAIRS.

a. All damage will be identified on aircraft inspection and maintenance record, DA Form 2408-13, DA Form 2408-14, and DA PAM 2408-18, as per DA PAM 738-751.

b. Recording of BDAR repairs and the use of status symbols, as defined in DA PAM 738-751, will be completed as soon as practical to indicate any limitations and restrictions or required standard repairs.

c. In addition to recording all damage, the area damaged will be marked on aircraft or component part using damage assessment markings as shown in Table 1-1.

d. Maintenance of Forms. Instructions for the maintenance of forms, records, and reports are listed in DA PAM 738-751. When BDAR becomes necessary, the procedures in DA PAM 738-751 will apply.

e. Temporary Repair. If the repair is temporary, take the following additional action:

(1) In block 18 of DA Form 2408-13, enter the corrective action and a statement that the repair is temporary. Then make an entry in DA Form 2408-14, block b. The entry will be a duplicate of the entry in block 17 of DA Form 2408-13 to include a statement that a temporary repair has been made.

Table 1-1. Damage Assessing Markings







<u>MEANINGS</u>	<u>MARKINGS</u>
<p>TO INDICATE DAMAGE HAS BEEN ASSESSED AND EVALUATED:</p> <p>Draw a circle around the damage.</p>	
<p>TO INDICATE NO BDAR REPAIR REQUIRED:</p> <p>Write "OK" inside the circle.</p>	
<p>TO INDICATE STRUCTURAL SKIN REPAIRS ARE REQUIRED:</p> <p>Draw a second line about 1/4 to 1/2 way around the initial circle then draw slashes or crosshatch between the two circular lines.</p>	
<p>STRINGER/LONGERON REPAIR: Place an X to the left and right of the circle.</p>	
<p>FRAME REPAIR: Place an X above and below the circle.</p>	
<p>TO INDICATE DAMAGE TO SYSTEMS REQUIRING REPAIRS:</p> <p>Draw a series of "curly cue" lines about 1/4 to 1/2 way around the initial circle.</p>	
<p>TO INDICATE REPAIR INSTRUCTIONS:</p> <p>For internal damage - draw a dashed circle around the repair instructions.</p>	
<p>For external damage - write repair instructions but do NOT enclose with a circle.</p>	<p>REPAIR INSTRUCTIONS REPAIR INSTRUCTIONS</p> <p>REPAIR INSTRUCTIONS PARTIAL</p>

Table 1-1. Damage Assessment Markings (Cont)

<u>WRITTEN INSTRUCTIONS</u>	<u>MEANING</u>
See me - print name & rank. (Signature)	See assessor or whoever has signed written instructions for additional information.
Names of parts to be repaired (item, skin, stringer).	Where compound damage occurs, the names or abbreviations of specific items can be written adjacent to the damage to clarify repair instructions.
Full	A full strength repair is required.
Partial	Partial strength repair required in accordance with specific aircraft BDAR manual.
OK	No repairs required - damage is within acceptable limits for battle conditions.
?	Continual assessment or reinspection is required after each sortie.

Instruction markings for system are in two parts:

- (1) Repair instruction markings and meanings are shown on this sheet and are used to indicate repair actions required.
- (2) System Identification - When known, identify the system using markings shown in this Table.

<u>MARKINGS</u>	<u>MEANING</u>
Fix	Repair the damaged system in accordance with approved standard BDAR techniques for type of system, item, high pressure, low pressure, etc.
Cap	Terminate or block the system to prevent leakage.
Repl	Replace damaged part - repairs not acceptable.
OK	No repairs required.
Tag	Repair instructions are written on tags tied to individual damaged lines/components.

Table 1-1. Damage Assessment Markings (Cont)

System identification markings are primarily abbreviations of the system.

<u>MARKINGS</u>	<u>SYSTEM/MEANING</u>
Sys	Damage to unknown system.
Fuel	Fuel
Hyd	Hydraulic
HP	High Pressure
LP	Low Pressure
Elec	Electrical
AV	Avionics
Flt Cont	Flight Control
Main Rotor	Main Rotor Group
Tail Rotor	Tail Rotor Group
Air	Pneumatic
Air Cond	Air Conditioning
BL Air	Bleed Air System
BLC	Boundary Layer Control
N ₂	Nitrogen
O ₂	Oxygen
Eng Contr	Engine Control
Pow Tr	Power Train
EJ	Ejection

NOTE

More than one identification marking may be used to describe the system (e.g., HP, Hyd).

(2) If the temporary repair limits the capability of the aircraft, the following entry will be made on DA Form 2408-13:

(a) Place a circled red "X" in block 16.

(b) State the limitation in block 17.

(3) If the temporary repair requires an inspection at intervals, list the required inspection on DA Form 2408-18.

(a) Enter item to be inspected in block 5.

(b) List the applicable TM in block 6.

(c) State the frequency of the inspection in block 7.

CHAPTER 2

ASSESSING BATTLEFIELD DAMAGE

BDAR FIXES SHALL BE USED ONLY IN COMBAT OR FOR TRAINING
AT THE DISCRETION OF THE COMMANDER.
(AUTHORIZED TRAINING FIXES ARE LISTED IN APPENDIX E.)
IN EITHER CASE, DAMAGES SHALL BE REPAIRED BY STANDARD
PROCEDURES AS SOON AS PRACTICABLE.

Section I. INTRODUCTION

2-1 SCOPE.

a. This chapter provides guidelines for use in assessing battlefield damage to the UH-1 utility helicopter. It directs you to a BDAR fix or to the standard system fix of TM 55-1520-210-23 if a BDAR repair does not exist. General decision logic chart, Table 2-1, assists in BDAR discussions.

b. Each chapter will have a specific fault assessment table for each functional group, and this flow chart will direct you to specific BDAR fixes for and within the functional group.

c. Use the following guidelines to find and fix sustained damage or suspected damage to your helicopter.

Keep in mind that damage can be sustained while on the ground or in flight. The helicopter location can have a considerable effect on the assessment. The following appraisal shall be accomplished.

d. If possible and time permits, inspect and check the helicopter using operator's checklist (CL), operator's manual (-10), and other records and forms kept in aircraft log book. At the same time be looking for obvious damage to aircraft.

e. After repairing the damage, replace all lost fluids/lubricants. If one specified by aircraft TM is not available, refer to Appendix D for alternative materials/parts.

Section II. FAULT ASSESSMENT

2-2. HELICOPTER FLIGHT ASSESSMENT. The helicopter flight assessment table, Table 2-2, guides you through the aircraft's systems so that all the necessary capabilities are evaluated. If a fault is found, Table 2-2 directs you to the chapter for the functional group which contains the fault. The BDAR assessment procedure will refer you

to a chapter in this manual, a standard TM 55-1520-210-23 repair if it is feasible, or a higher level of repair if extent of damage, time constraint, tooling requirements, repair part or material, and any other necessary requirements are only available at a higher level of maintenance.

Table 2-1. General Decision Logic

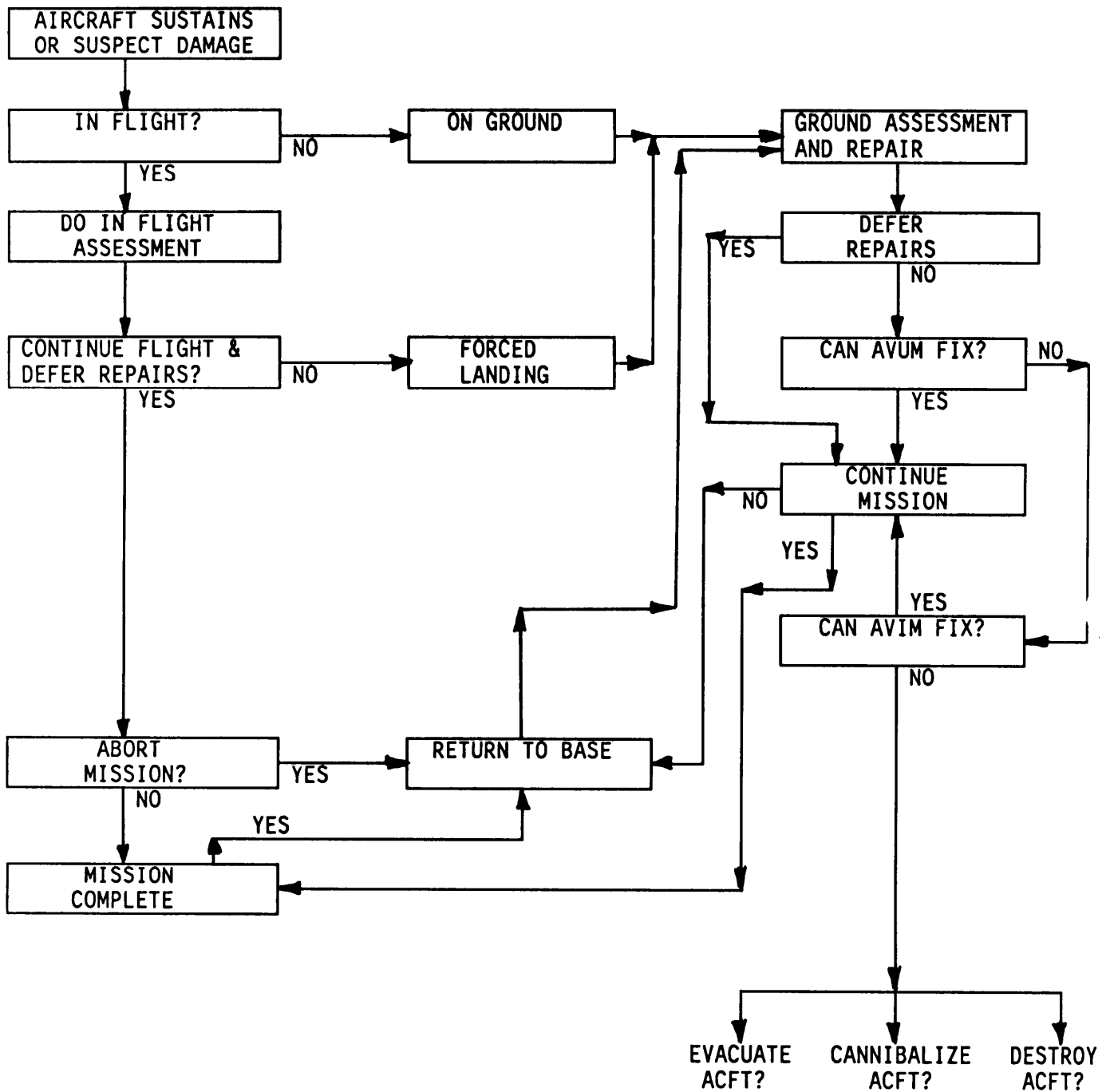

Table 2-2. Helicopter Flight Assessment (Cont)

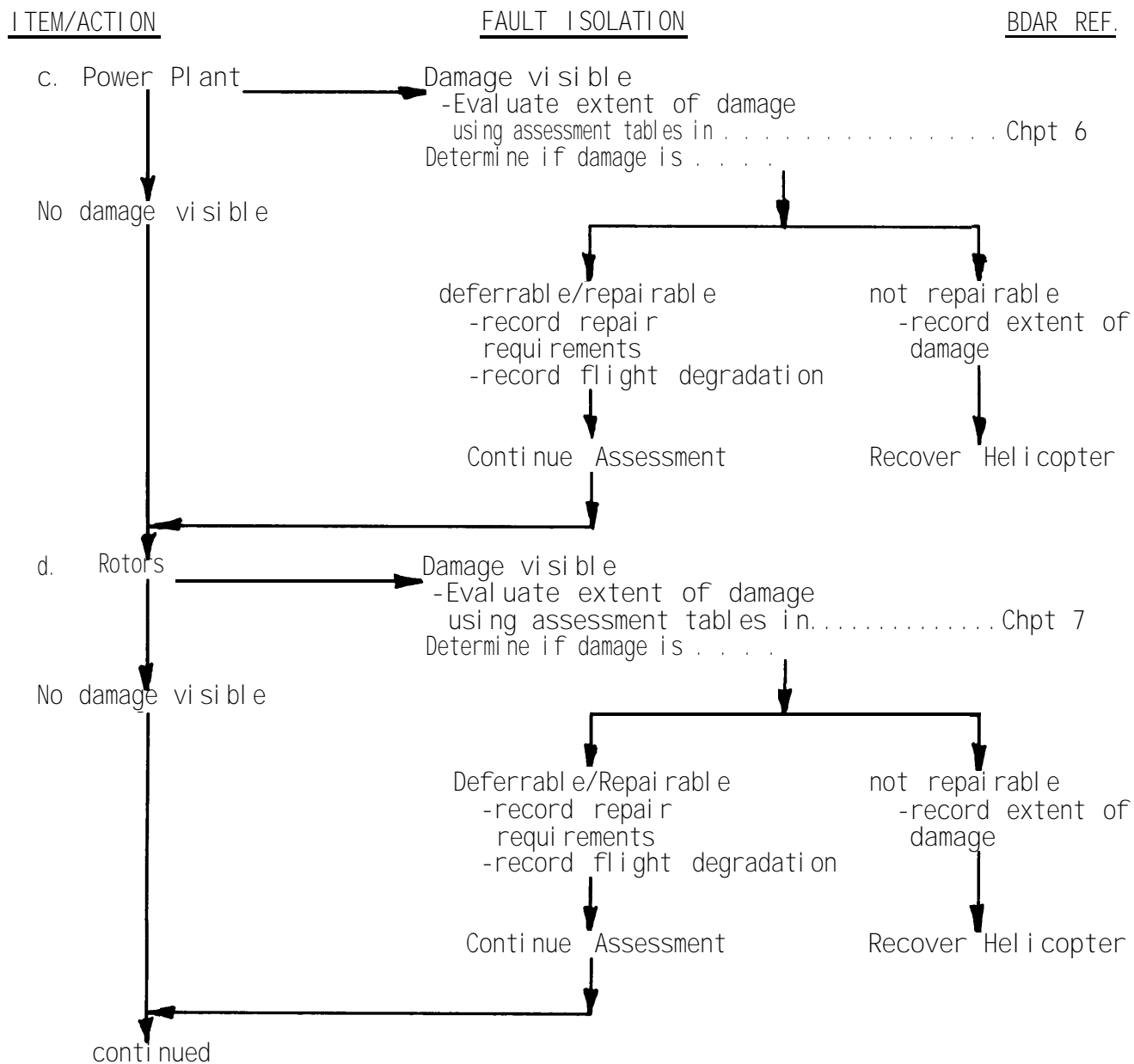

Table 2-2. Helicopter Flight Assessment (Cont)

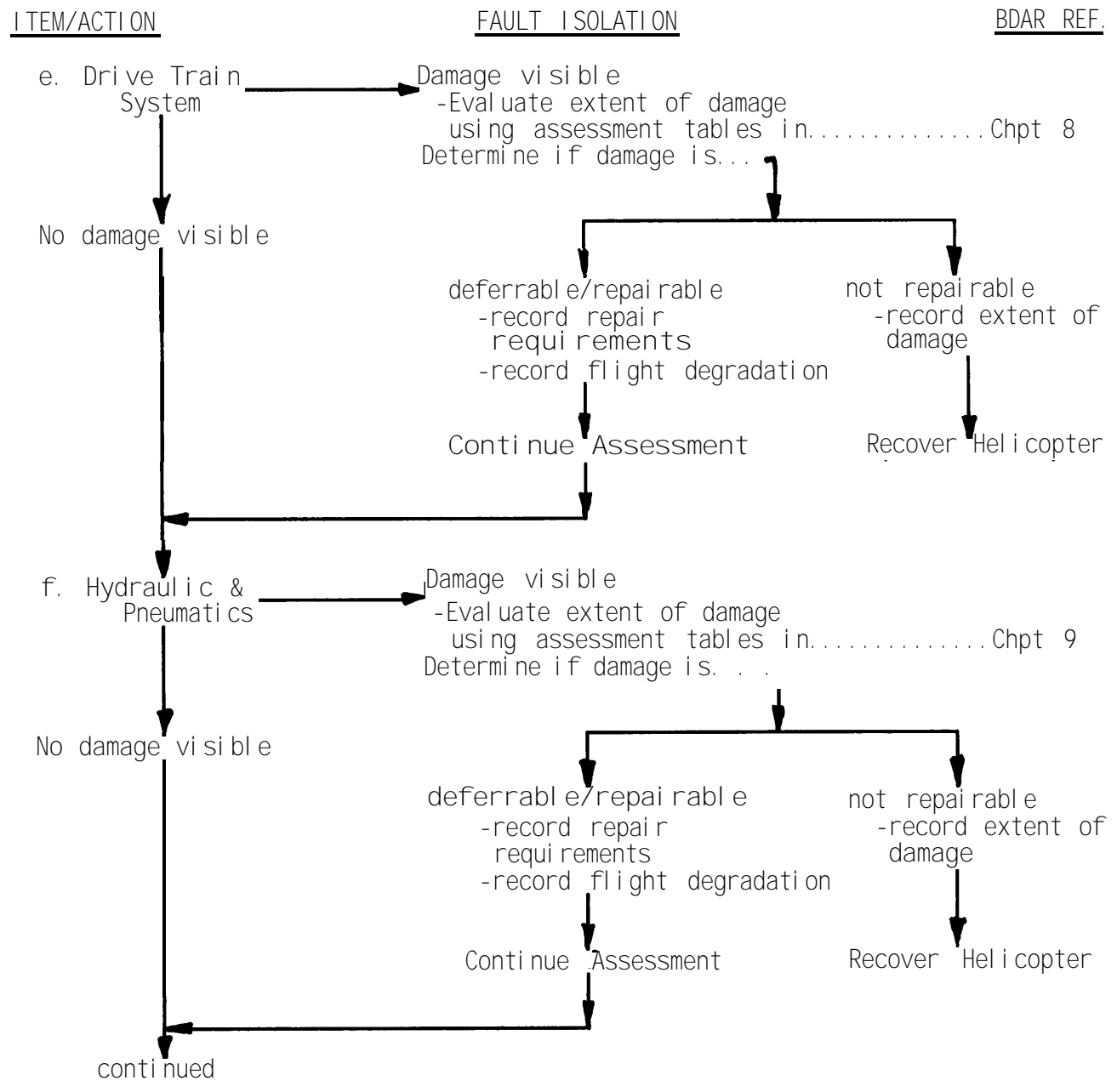

Table 2-2. Helicopter Flight Assessment (Cont)

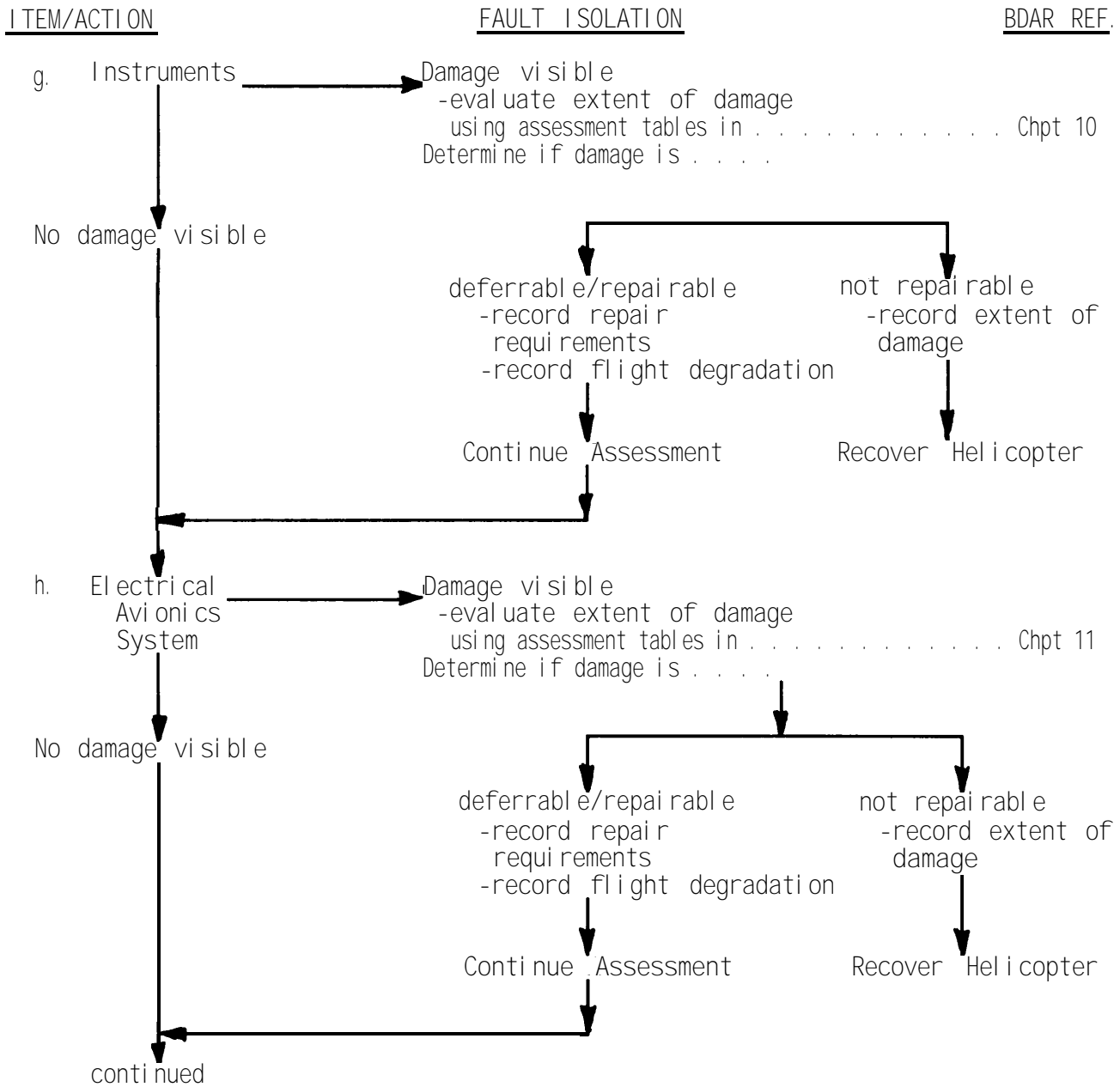

Table 2-2. Helicopter Flight Assessment (Cont)

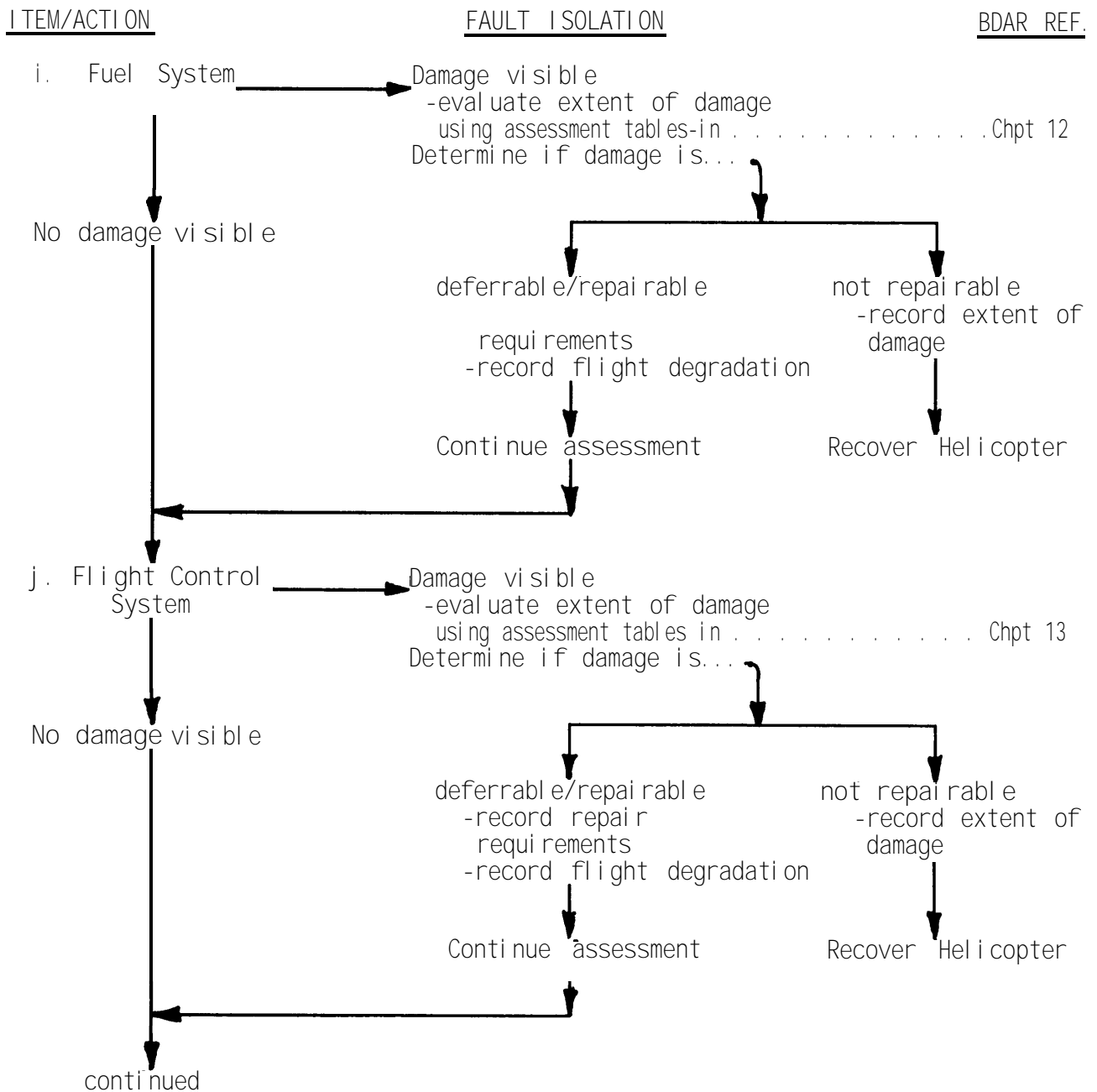
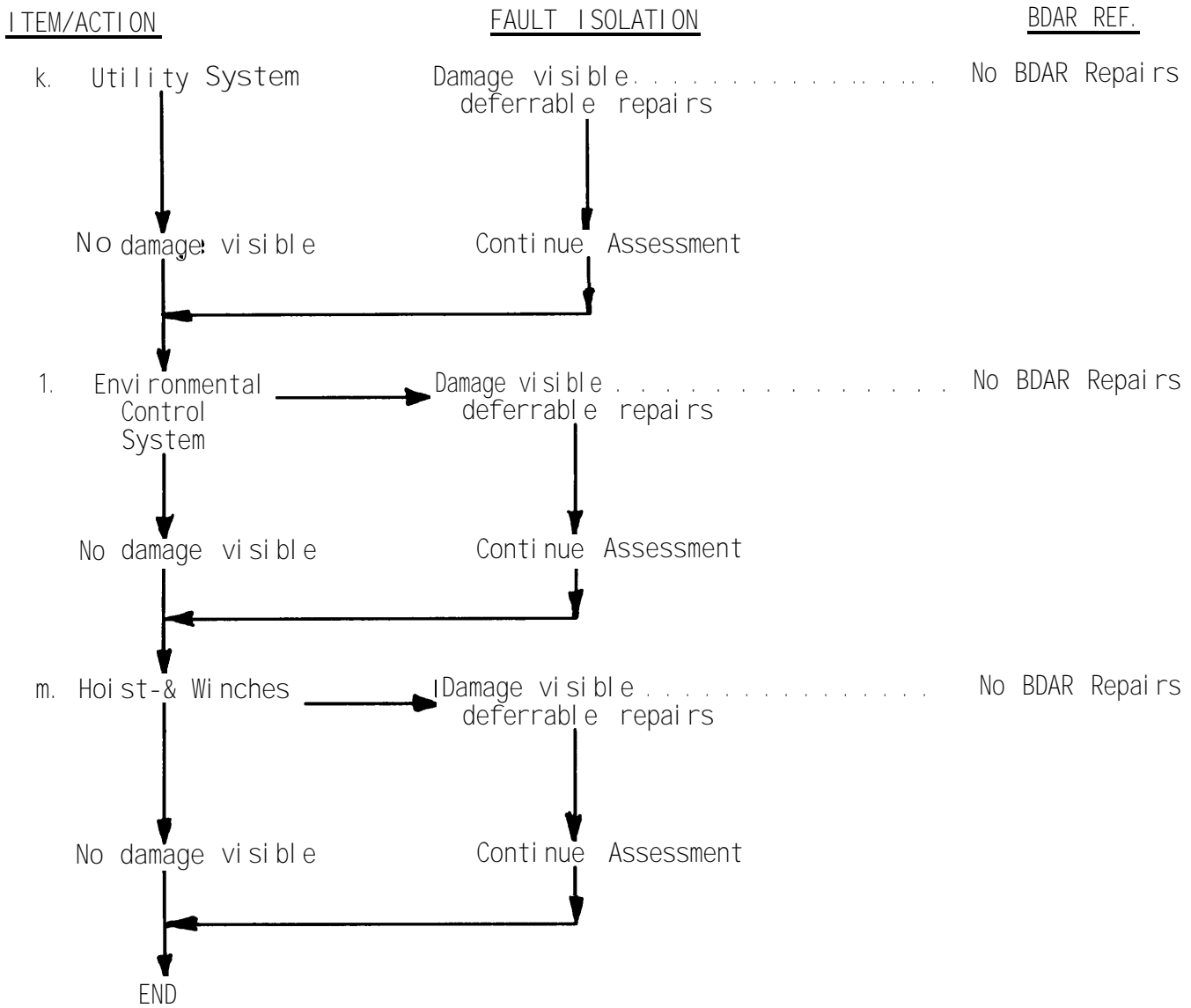

Table 2-2. Helicopter Flight Assessment (Cont)



CHAPTER 3

GENERAL REPAIRS

BDAR FIXES SHALL BE USED ONLY IN COMBAT OR FOR TRAINING
 AT THE DISCRETION OF THE COMMANDER.
 (AUTHORIZED TRAINING FIXES ARE LISTED IN APPENDIX E.)
 IN EITHER CASE, DAMAGES SHALL BE REPAIRED BY STANDARD
 PROCEDURES AS SOON AS PRACTICABLE.

Section I. INTRODUCTION

3-1. SCOPE. This chapter provides information for BDAR of items that are not necessarily associated with a specific component or specific subsystem of the helicopter and which are not available in other manuals. It provides general repair procedures to use in more than one area of the helicopter. These fixes are designed to be expedient repairs using minimum amount of tools and standard common materials. The experienced technician/mechanic will easily be able to find equivalent substitute materials and tools. The materials listed in text and in Appendix C are only recommendations. Any equivalent substitute is acceptable.

3-2. ASSESSMENT PROCEDURES. Use the planned steps defined in Chapter 1, paragraph 1-4.c, and the helicopter flight assessment.

3-3. REPAIR PROCEDURE INDEX.

	PARA.
Skin Damage	3-5
Stiffener/Stringer Damage	3-7
Longerons/Caps Severed	3-9
Bulkhead and Former Frames, Major Damage	3-11
Bulkhead and Former Frames, Minor Damage	3-12
Honeycomb Panels, Damaged 2 inch Max Dia	3-14
Honeycomb Panels, Damaged 2 to 8 Inches in Dia	3-15
Honeycomb Panels, Damaged 12 by 12 Inches.	3-16

Section II. SKIN STRUCTURE

3-4. GENERAL.

a. Helicopter structure is specified as primary structure which holds the helicopter together and secondary structure which mounts on primary structure.

b. Skin damage or damage to secondary structure which occur by itself with no damage to primary structure is normally confined to a very small area (e.g., between longerons and stringers). This type of damage is deferrable if it poses no other problems.

c. Skin damage, which in itself does not degrade structure but which can cause other problems, must be removed.

d. Structural and skin metal substitution is allowed per Appendix D, Section V.

3-5. SKIN DAMAGE. Skin damage of less than 1-1/2 inches in diameter can be deferred and repaired later per TM 55-1520-210-23. Repair as follows:

LIMITATIONS: None.

PERSONNEL/TIME REQUIRED:

- Soldier
- 15 Minutes

MATERIALS/TOOLS REQUIRED:

- Adhesive Tape (items 153, 156, App C)
- Tools (App B)
- Aluminum Sheets (item 135, App C)
- Cherrymax Rivets (items 94-114, App C)

PROCEDURAL STEPS:

1. If the damage is less than 1-1/2 inches in diameter, apply adhesive tape to hole. Overlap tape 2 inches minimum around the hole.

2. If the damage is 1-1/2 inches or larger, repair the hole as follows:

- a. Trim and cut out all cracks.
- b. Smooth edges with file.
- c. Apply a metal overlay patch using standard rivet pattern.
- d. Use cherrymax rivets.

3. Record BDAR action taken. When mission is complete, as soon as practical, repair the equipment/system using standard maintenance procedures.

Section III. STIFFENER AND STRINGERS

3-6. GENERAL.

a. Stiffeners and stringers are similar to longerons structural members. Their damage will range from either complete failure as in total separation and break to just deformation by over stress loading. In most cases, the skin over the stringers member will also be damaged. The damage causes will be varied, but the general causes can be as impact damage (i.e., by projectiles) concussion from explosions and over stress loading damage. Damage will be evident as breaks, cracks, holes, tears, buckling, bending, wrinkled, twisted, and stretched metal skin or stringer.

b. Fixes in this section are designed to be expedient repairs to restore as much of original structure strength as possible without regards to weight or appearance. Over stress damage can cause internal damage to stringers without rupturing the skin.

c. Fixes to stiffeners/stringers are listed in order of optional preference. Consideration to time, materials and tools available should be given.

3-7. STIFFENERS AND STRINGERS, DAMAGED.

GENERAL INFORMATION: These repairs are applicable to any skin stiffener structure on the helicopter. Two options are provided for repair. Option one is adding an external skin stiffener; option two is combining both external stiffener and skin patch.

OPTION 1: Reinforcing External Stiffener/Stringer.

LIMITATIONS: None.

PERSONNEL/TIME REQUIRED:

- 2 Soldiers
- 30 Minutes

MATERIALS/TOOLS REQUIRED:

- Extrusion Angle, Aluminum or Steel (item 59, App C)
- Drill Bit (item 67, Sec II, App B)
- Drill Motor (item 69, Sec II, App B)
- Rivets (items 94-114, App C)
- Hand Rivet Puller (items 147-150, Sec II, App B)
- Locating & Drill Fixture (items 90-91, Sec II, App B)

PROCEDURAL STEPS:

1. If the damaged stiffener/stringer is lightweight and the bordering stringer and former are not damaged, apply an external bridging stiffener/stringer patch without regards to skin damage. Defer the skin damage until later.

2. Stop drill all cracks, but do not remove all damage. See Figure 3-1.

3. Use an angle or other suitable extrusion to bridge the damage. Metal size and thickness should be equal to or greater than original stiffener/stringer.

4. Remove a minimum of eight existing rivets in undamaged area on both ends of damage. Using a rivet hole drill and locating fixture, locate, drill and rivet the repair piece of bridging extrusion in place as shown in Figure 3-1.

5. Record BDAR action taken. When mission is complete, as soon as practical, repair the equipment/system using standard maintenance procedures.

OPTION 2: Sheet Metal Patch and External Stiffener/Stringer.

LIMITATIONS: None.

PERSONNEL/TIME REQUIRED:

- 2 Soldiers
- 60 Minutes

MATERIALS/TOOLS REQUIRED:

- Angle Extrusion (items 47-61, App C)
- Drill Bit (item 67, Sec II, App B)
- Drill Motor (item 69, App B)
- Hand Rivet Puller (items 147-150, Sec II, App B)
- Rivet Hole Drill and Locating Fixture (items 90-91, Sec II, App B)
- Sheet Metal (items 129-141, App C)

PROCEDURAL STEPS:

1. Cut out the damaged skin and stiffener/stringer. Smooth and round the cutout. Clean up the ends of the stringer, Figure 3-2. If it is not possible to remove all the cracks, stop drill cracks.

2. Cut and fit a skin patch of the same material or one gage thicker than original. Steel sheet metal substitution per Table D-8, Appx D. Allow for an overlap for a minimum of two rows of cherry rivets as shown in Figure 3-2.

3. Cut a piece of substitute stringer to extend a minimum of eight inches or eight rivets beyond the damage on each end. Use an angle, channel, or tee extrusion with a cross section and strength equal to or greater than the original existing stiffener/stringer. If damage area is next to another damage area on the same stringer, extend the stringer to cover the damage of both areas.

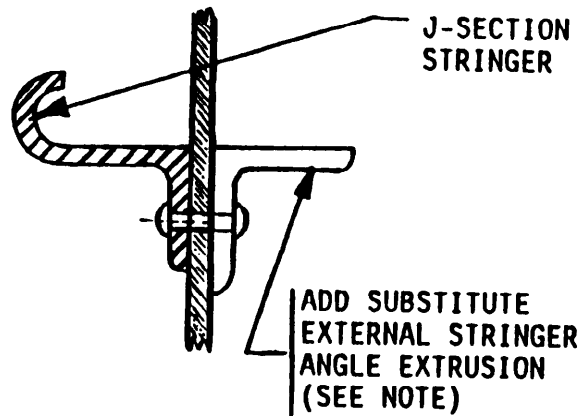
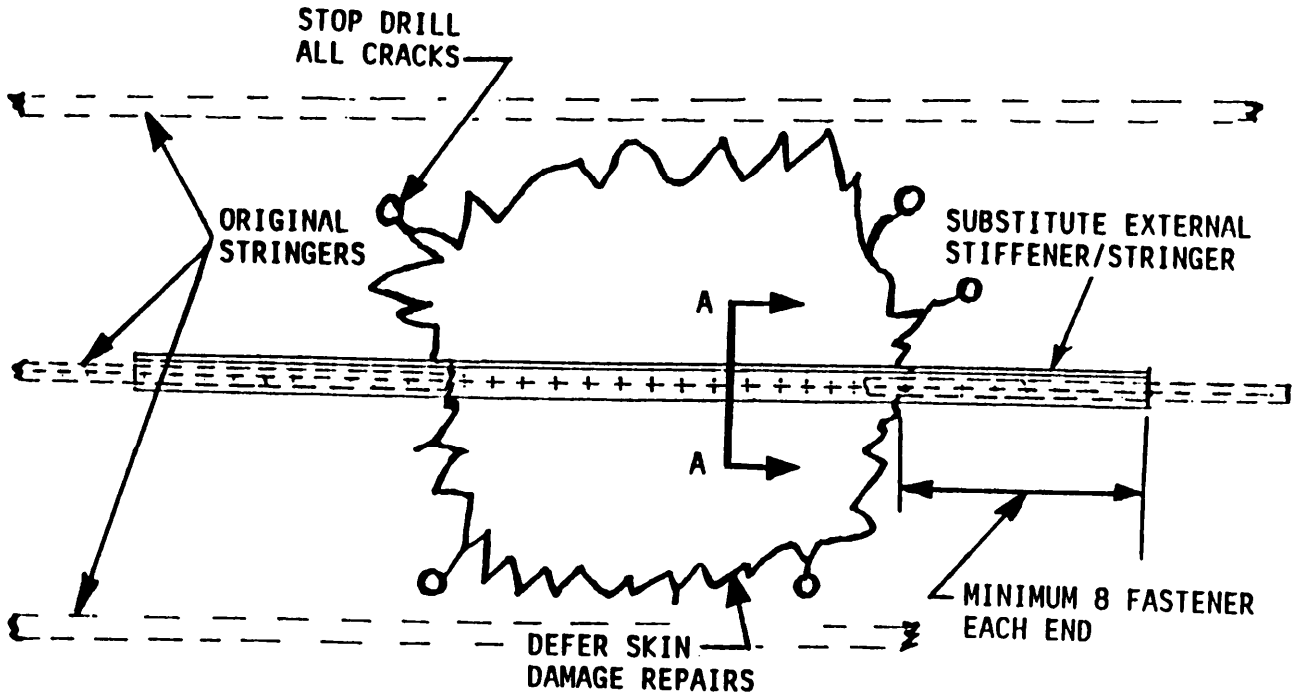

SECTION A-A

Figure 3-1. External Stiffener/Stringer Patch

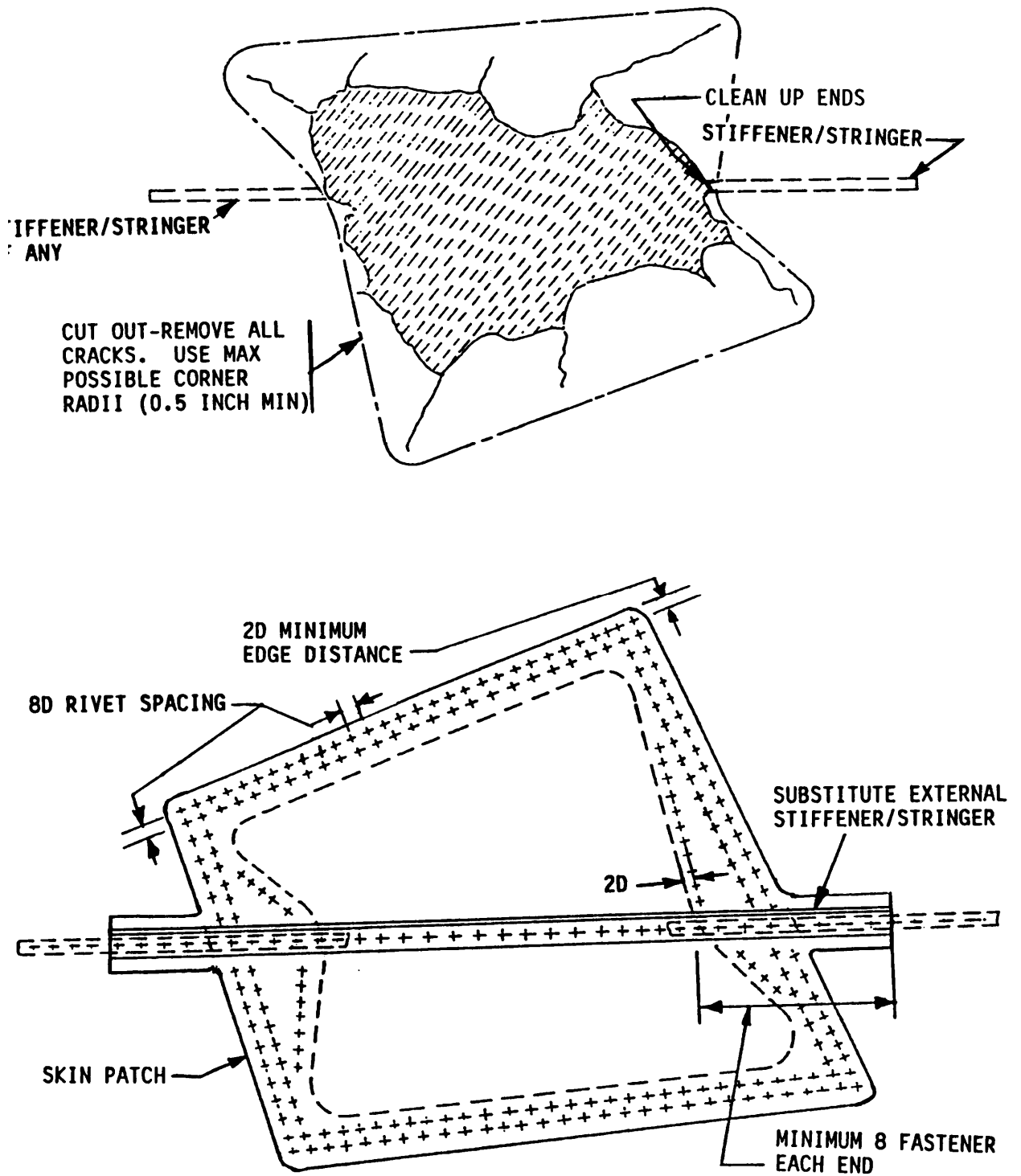

Figure 3-2. Patch Plate

4. Remove rivets in the existing stiffener/stringer and back drill rivet holes in the substitute stiffener/stringer. If the area is unaccessible for back drilling, use a rivet locating and drilling fixture to locate and drill new holes to match old rivet hole pattern.

5. Rivet the skin patch and stiffener in place using the same size rivets as the originals, or one size larger diameter.

NOTE

The placement of stiffener/stringer on the outside of the skin is strictly for expediency. If time permits and accessibility of damaged area permit, stiffener/stringer can be installed internally.

6. Record BDAR action taken, When mission is complete, as soon as practical, repair the equipment/system using standard maintenance procedures.

Section IV. LONGERONS AND CAPS

3-8. GENERAL.

a. Longerons and caps are normally primary structures which hold the helicopter airframe together. Longerons and caps damaged will invariably result in damage to the skin at the same time. Longeron/cap damage which is severe to complete failure such as complete separation and missing sections will require reinforcement repairs.

b. Repairs listed in this section are expedient temporary repairs. For permanent repairs, consult TM 55-1520-210-23.

3-9. LONGERONS AND CAPS, SEVERED.
(Complete failure/separation.) See Figure 3-3.

LIMITATIONS: This temporary repair will be inspected after every flight, and permanent repair will be completed as soon as practical.

PERSONNEL/TIME REQUIRED:

- 2 Soldiers
- 2 Hours

MATERIALS/TOOLS REQUIRED:

- Angle Extrusion (items 47-61, App C)
- Cherrymax Rivets (items 96-114, App C)
- Drill Bit Set (item 67, Sec II, App B)
- Drill Motor (item 69, App B)
- Hand Rivet Puller (item 147-150, Sec II, App B)
- Drill & Locating Fixture (items 90-91, Sec II, App B)

PROCEDURAL STEPS: Repair the damaged area with material of the same cross section as damaged member if available, or use a substitute material such as angle or channel extrusion, or corrugated sheet metal. For expediency, the longeron/cap used in this repair will be riveted on external side of skin using cherrymax rivets.

1. Remove sections of the helicopter skin containing the damage. This will allow access to the inside for inspection and repair steps. Do not remove any more skin than is necessary to remove all cracks. Do not shorten the longeron/cap, but only remove the damaged ends.

2. If time and material availability permit, patch the skin with a sheet metal patch of same material but one gage thicker, or a stronger material. Patch per basic instructions in TM 55-1500-204-25/1.

3. Cut substitute longerons/cap from angle or channel extrusion. The cross section of substitute longeron should be greater and stronger than the original metal. Cut the repair piece length to bridge the damage and to extend a minimum of 18 inches on both sides, overlapping the existing longeron. If space permits, install two angle extrusions as shown in Figure 3-3.

4. In the area where the substitute longeron/cap will overlap the damaged longeron section, remove the old rivets which attach the longeron to the skin. Remove rivets for a minimum of 18 inches.

5. Place the substitute longeron in place on the outside of the skin surface. Back drill or mark for rivet holes through the existing holes on the damaged and trimmed longeron/cap, or use a rivet hole drill and locating fixture.

6. Rivet the substitute longeron/cap in place using the cherrymax rivets.

7. Record BDAR action taken. When mission is complete, as soon as practical, repair the equipment/system using standard maintenance procedures.

Section V. BULKHEAD AND FORMER FRAMES

3-10. GENERAL.

a. Bulkheads and former frames are primary load carrying structures. Severe damage which reduces the cross section from 1/2 to complete separation will require substantial work to repair. Consideration should be given to using a permanent repair as authorized in TM 55-1520-210-23. If this is not possible, use the following expedient temporary repairs.

b. Severe damage (Figure 3-4) which destroys 50 to 100 percent of the cross section of a bulkhead or former frame will be repaired per paragraph 3-11.

c. Minor damage (Figure 3-4) which destroys 50 percent or less of the cross section of a bulkhead or former frame will be repaired per paragraph 3-12.

3-11. BULKHEAD AND FORMER FRAMES, MAJOR DAMAGE.

GENERAL INFORMATION: Damage which completely destroys one side of the bulkhead or former to where it is considered separated will be reinforced on both the inside and outside per this

paragraph and Figure 3-5. For more repair procedures on formers, consult TM 55-1520-210-23 and TM 55-1500-204-25/1.

LIMITATIONS: Inspect after every flight.

PERSONNEL/TIME REQUIRED:

- 2 Soldiers
- 3 Hours

MATERIALS/TOOLS REQUIRED:

- Aluminum Tape, Pressure Sensitive (item 153, App C)
- Cherrymax Rivets (items 96-114, App C)
- Sheet Metal (items 129-141, App C)
- Rivet Hand Pulling Tool (item 147-150, Sec II, App B)
- Drill & Locating Fixture (item 90-91, Sec II, Appx B)

PROCEDURAL STEPS:

1. Refer to Figure 3-5 for this procedure.

2. Remove sections of the skin and bulkhead/frame containing the damage. Smooth and round the cutout as shown.

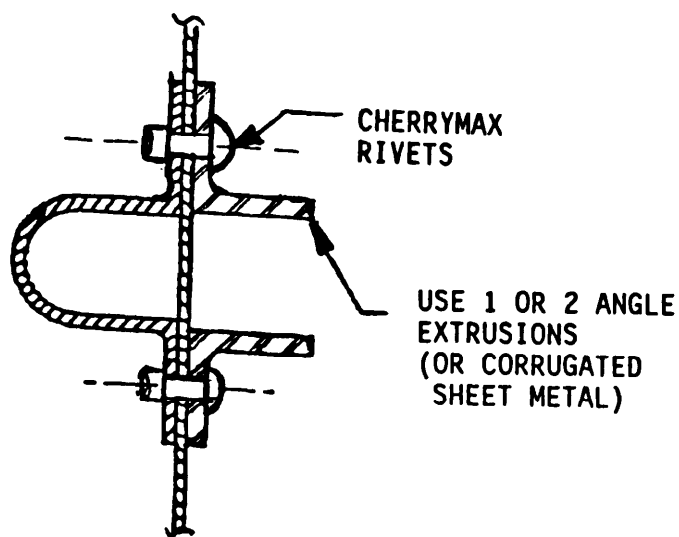
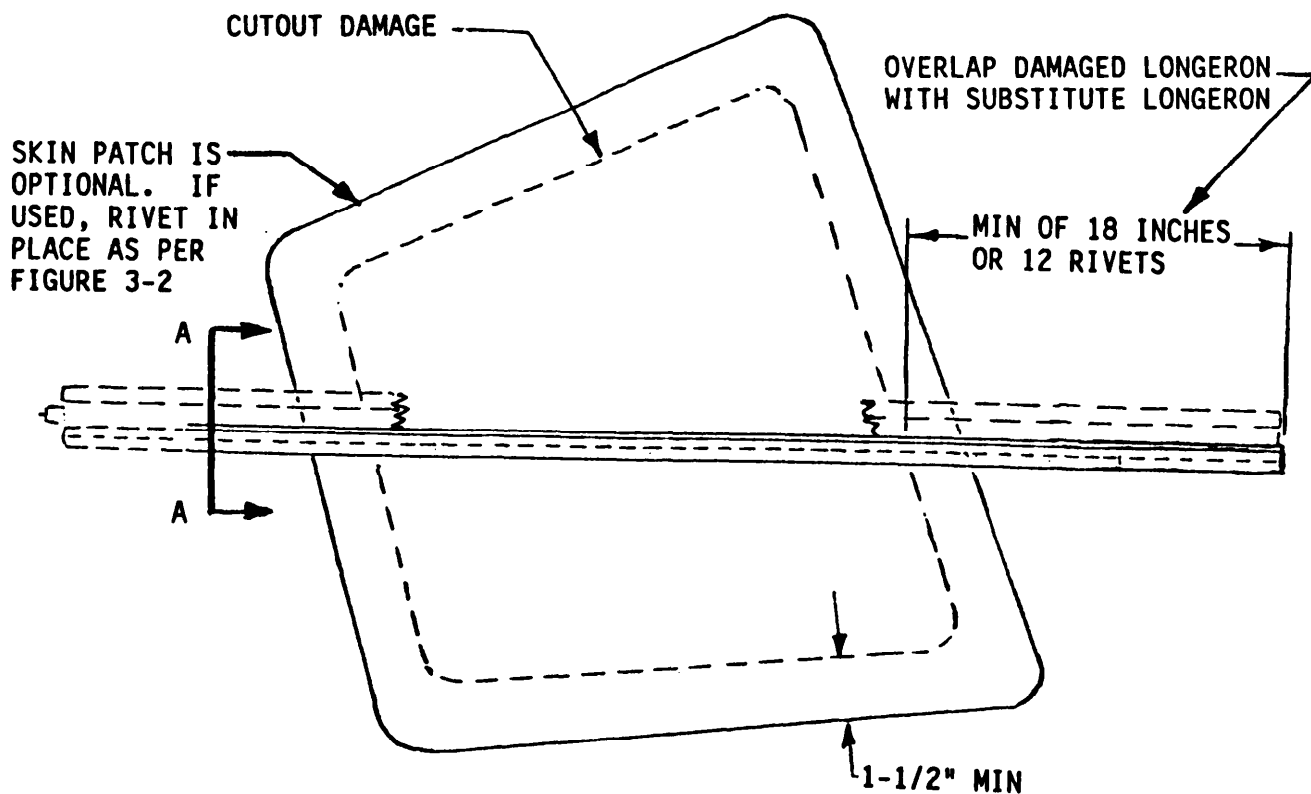

SECTION A-A

Figure 3-3. Expedient Longeron/Cap Repair

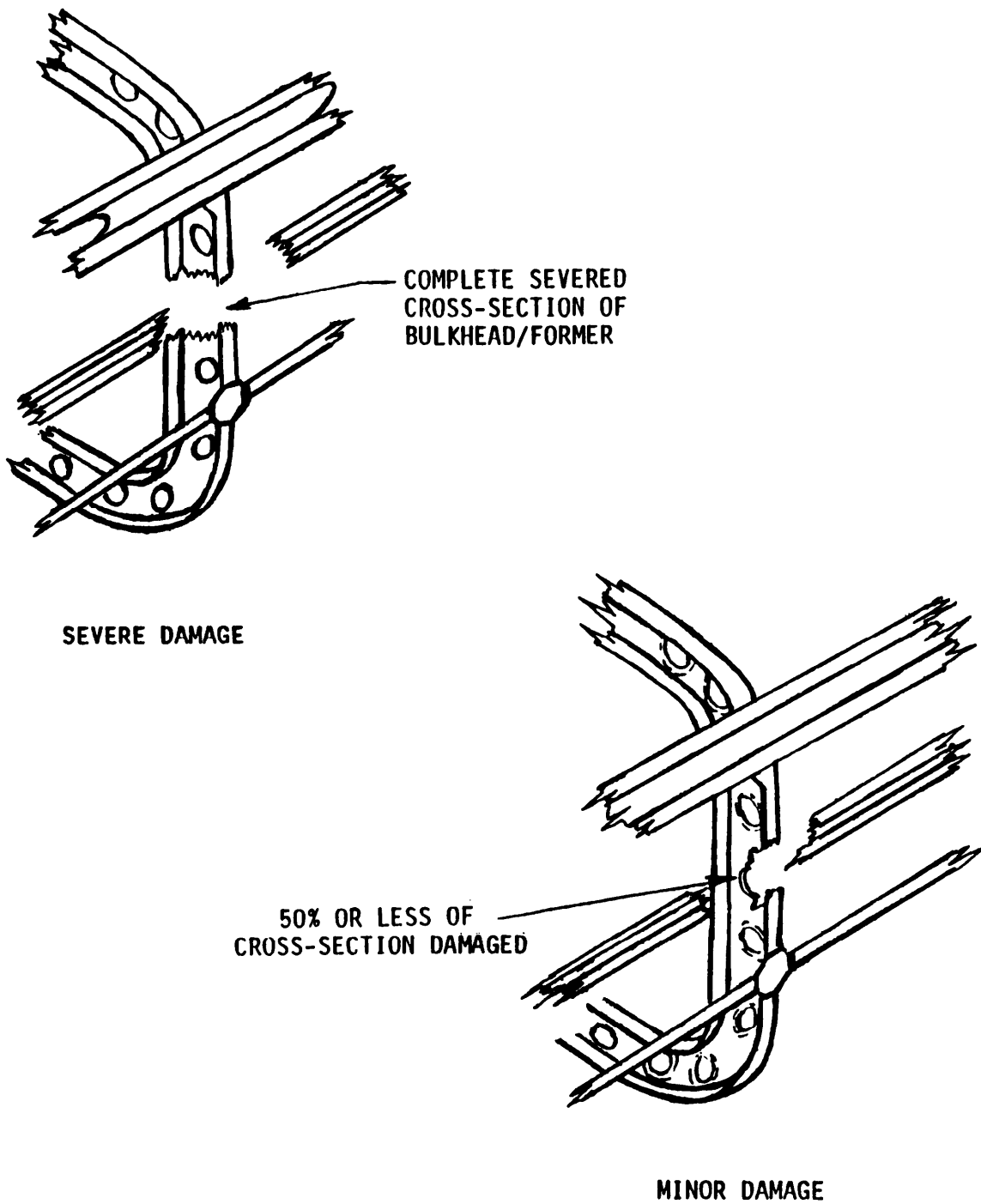

Figure 3-4. Bulhead and Former Damage

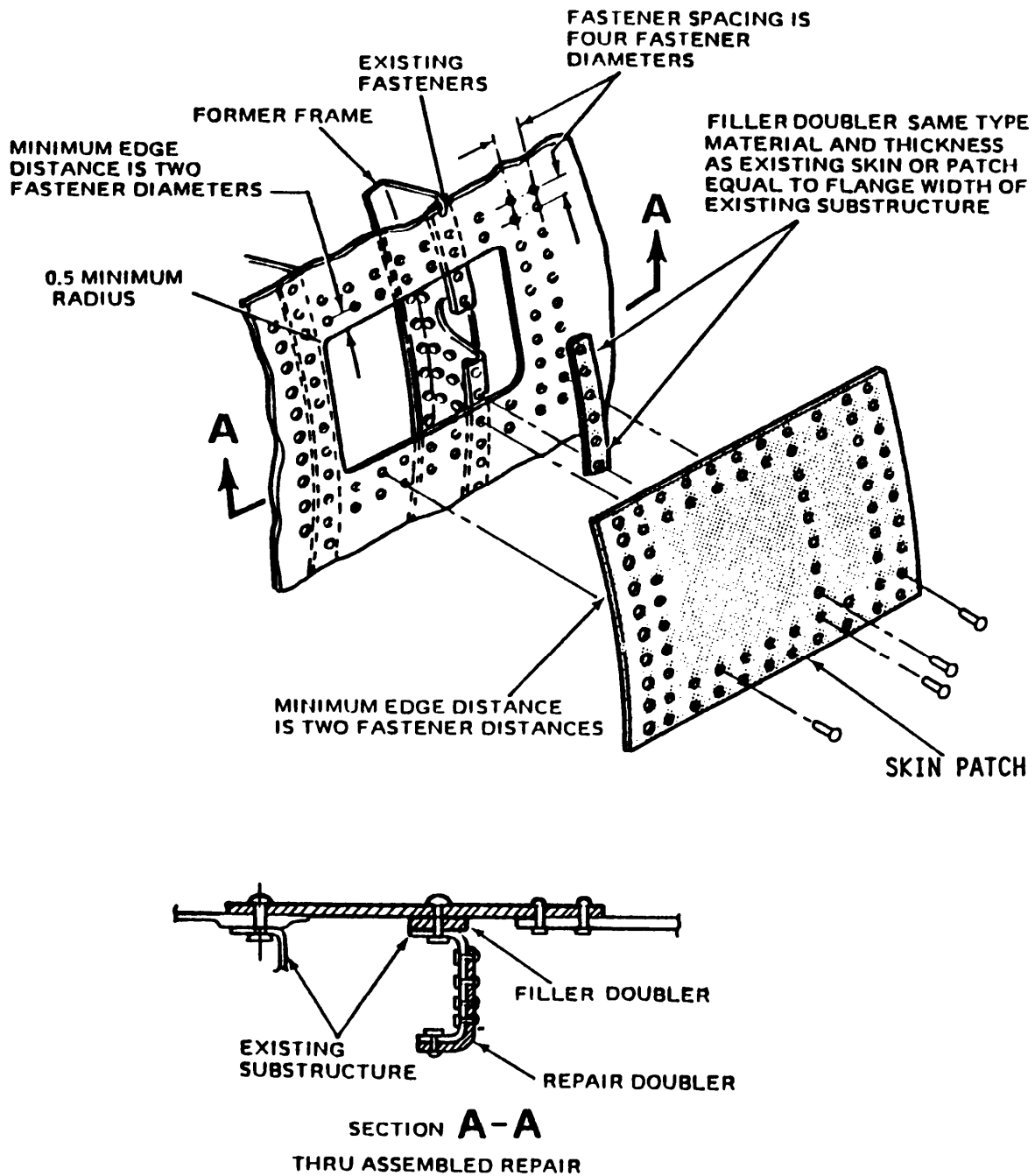

Figure 3-5. Typical Bulthead and Former Repair (Sheet 1 of 2)

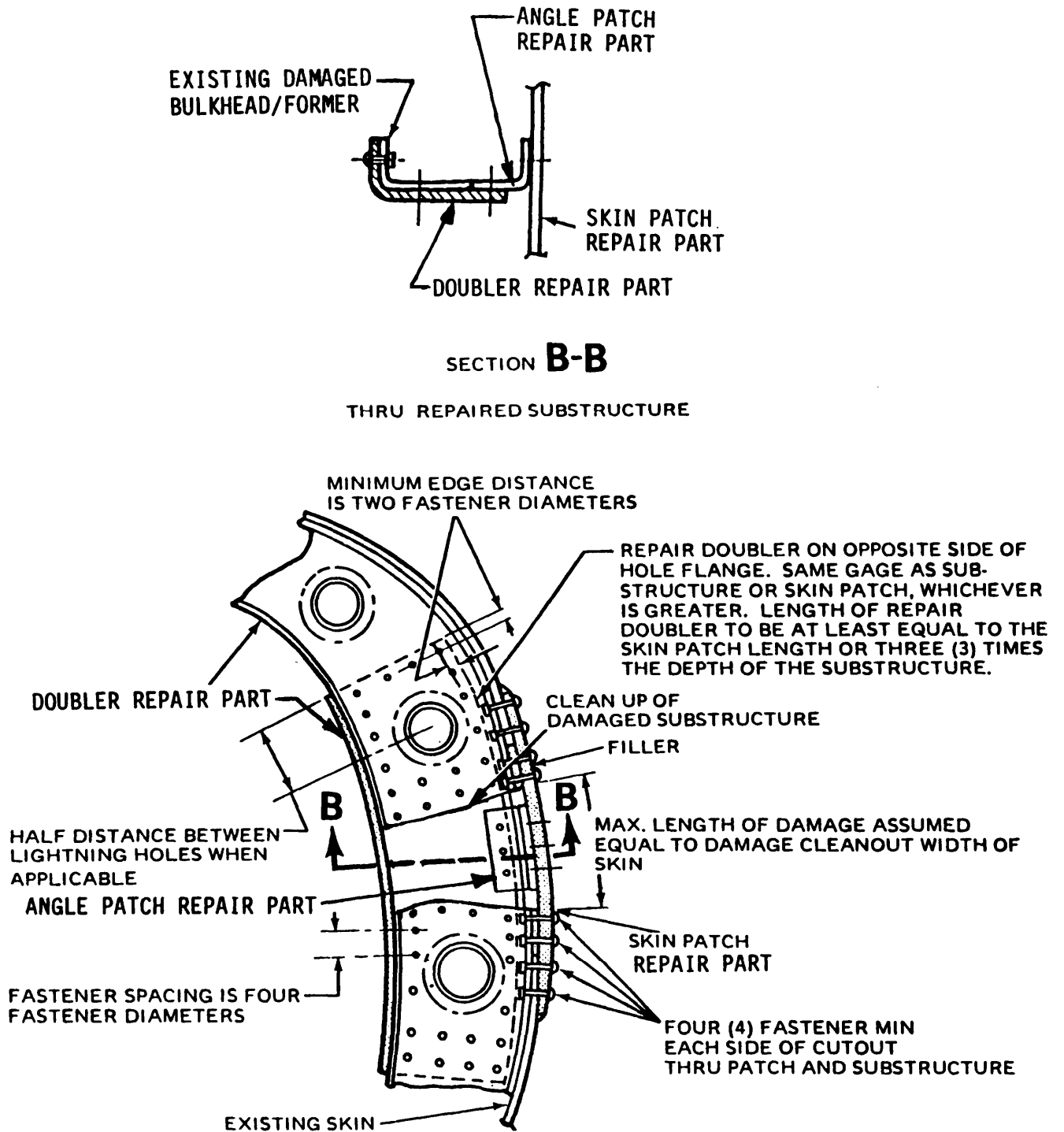

Figure 3-5. Typical Bulkhead and Former Repair (Sheet 2 of 2)

TM 55-1520-210-BD
GENERAL REPAIRS

3. Cut and fit repair doubler to inside flange of bulkhead/frame. Cut repair skin patch allowing overlap for at least four rows of rivets. Skin patch and inside doubler should be of the same material and one gage thicker than the original material. The filler doubler must be of the same thickness of original material.

4. Remove existing rivets where the repair parts will overlap existing rivets. If the area is not accessible for back drilling, use rivet hole drill and locating fixture to locate rivet holes in the repair pieces. As an alternate method, it may be possible to install repair rivets interspaced between existing rivets.

5. Rivet the repair pieces in place with cherrymax rivets of same diameter as original or one size larger if necessary.

6. Record BDAR action taken. When mission is complete, as soon as practical, repair the equipment/system using standard maintenance procedures.

3-12. BULKHEAD AND FORMER FRAMES, MINOR DAMAGE.

GENERAL INFORMATION: A damaged outside flange on a bulkhead or frame which does not exceed 50 percent of cross section of bulkhead can be repaired with an external reinforcement skin patch plate or extrusion, Figure 3-6.

OPTION 1: Patch plate repair for minor damage to bulkhead and frames where skin contour is from flat to single place curved.

LIMITATIONS: Inspect the repair area after every flight.

PERSONNEL/TIME REQUIRED:

- 2 Soldiers
- 3 Hours

MATERIALS/TOOLS REQUIRED:

- Aluminum Tape, Pressure Sensitive (item 153, App C)
- Cherrymax Rivets (items 96-114, App C)
- Drill Bit Set (item 67, Sec II, App B)
- Drill Motor (item 69, Sec II, App B)
- Rivet Hand Pulling Tool (items 147-150, Sec II, App B)
- Drill and Locating Fixture (items 90-91, Sec II, App B)
- Sheet Metal Strap Patch, Aluminum or Steel (items 129-141, App C)

PROCEDURAL STEPS:

1. Refer to Figure 3-6, sheet 1 of 2, for this procedure.

2. Stop drill all cracks, but do not remove the damage metal unless time permits.

3. Cover the damage hole with aluminum tape.

4. Fabricate repair strap using sheet metal twice as thick as the combined thickness of skin; flange and stringer (if any are present).

5. Form the repair strap to fit the contour of the skin. The strap should be wide enough to cover damaged area and to allow at least two rows of rivets spaced at six rivet diameters on the skin, and a minimum of six rivet in the undamaged portion of damaged stringers if any present. The strap length should be enough to overlap both ends of the damaged bulkhead or frame flange by six rivets at each end. In the area where repair strap will overlap on the damaged bulkhead flange and stringer, remove rivets and backdrill. If the area is not accessible, backdrilling is not feasible. Locate new holes by using rivet hole drill and locating fixture.

6. Rivet the repair strap to the bulkhead or frame flange and stringer using the same size rivets or one size larger cherrymax rivets. Rivet the strap to the skin using two rows of rivets around the perimeter using the same size rivets or one size larger.

7. Record BDAR action taken. When mission is complete, as soon as practical, repair the equipment/system using standard maintenance procedures.

OPTION 2: Channel or angle extrusion repair for minor damage to bulkhead and frames where the damage area is in a fairly straight contour.

LIMITATIONS: Inspect the repair area after every flight.

PERSONNEL/TIME REQUIRED:

- . 2 Soldiers
- . 2 Hours

MATERIALS/TOOLS REQUIRED:

- Aluminum Tape, Pressure Sensitive (Item 153, App C)
- Channel or Angle Extrusion Strap Patch, Aluminum or Steel (Items 47-61, App C)
- Cherrymax Rivets (item 112, App C)
- Drill Bit Set (item 67, Sec II, App B)
- Drill Motor (item 69, Sec II, App B)
- Rivet Hand Pulling Tool (items 147-150, Sec II, App B)
- Drill & Locating Fixture (items 90-91, Sec II, App B)

PROCEDURAL STEPS:

1. Refer to Figure 3-6, sheet 2 of 2, for this procedure.

2. Stop drill all cracks, but do not remove the damage metal unless time permits.

3. Cover the damage hole with aluminum tape.

4. Select channel or L shaped angle extrusion that is wide enough for three rows of rivets spaced at four to six rivet diameters apart. The length of strap should cover the damage in center; plus an overlap on each end to allow for six rows of rivets spaced at six rivet diameters. In the area where the repair strap will overlap on the damaged bulkhead flange and stringers, remove rivets and drills. If the area is not accessible for backdrilling, use a rivet hole drill and locating fixture to drill rivet holes in the new repair piece and match the old rivet hole pattern. Interpitching new rivets between existing rivets is also possible if space allows.

5. Rivet the repair strap to the bulkhead or frame flange and stringer using the same size rivets or one size larger cherrymax rivets.

6. Record BDAR action taken. When mission is complete, as soon as practical, repair the equipment/system using standard maintenance procedures.

STRAP 2 X "A" THICK SHEET
 METAL OR ANGLE STOCK TO BE
 LONGER THAN LENGTH OF DAMAGE

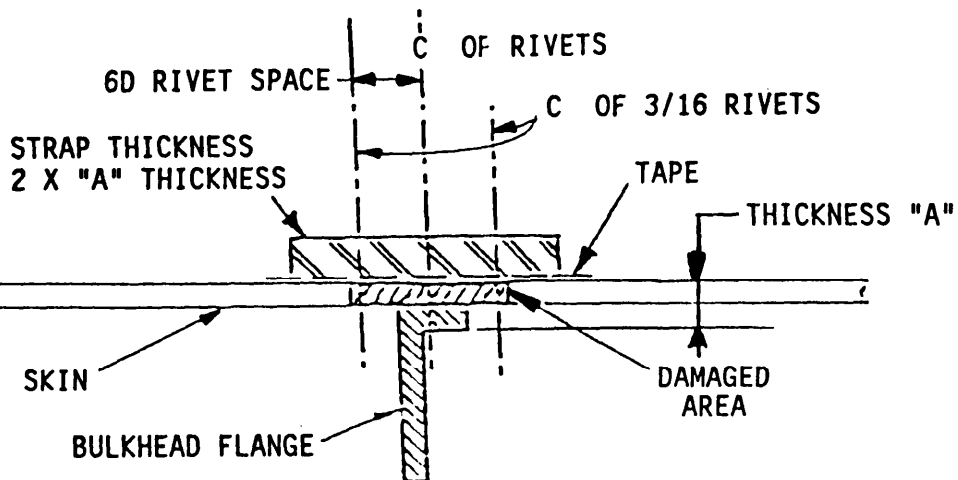
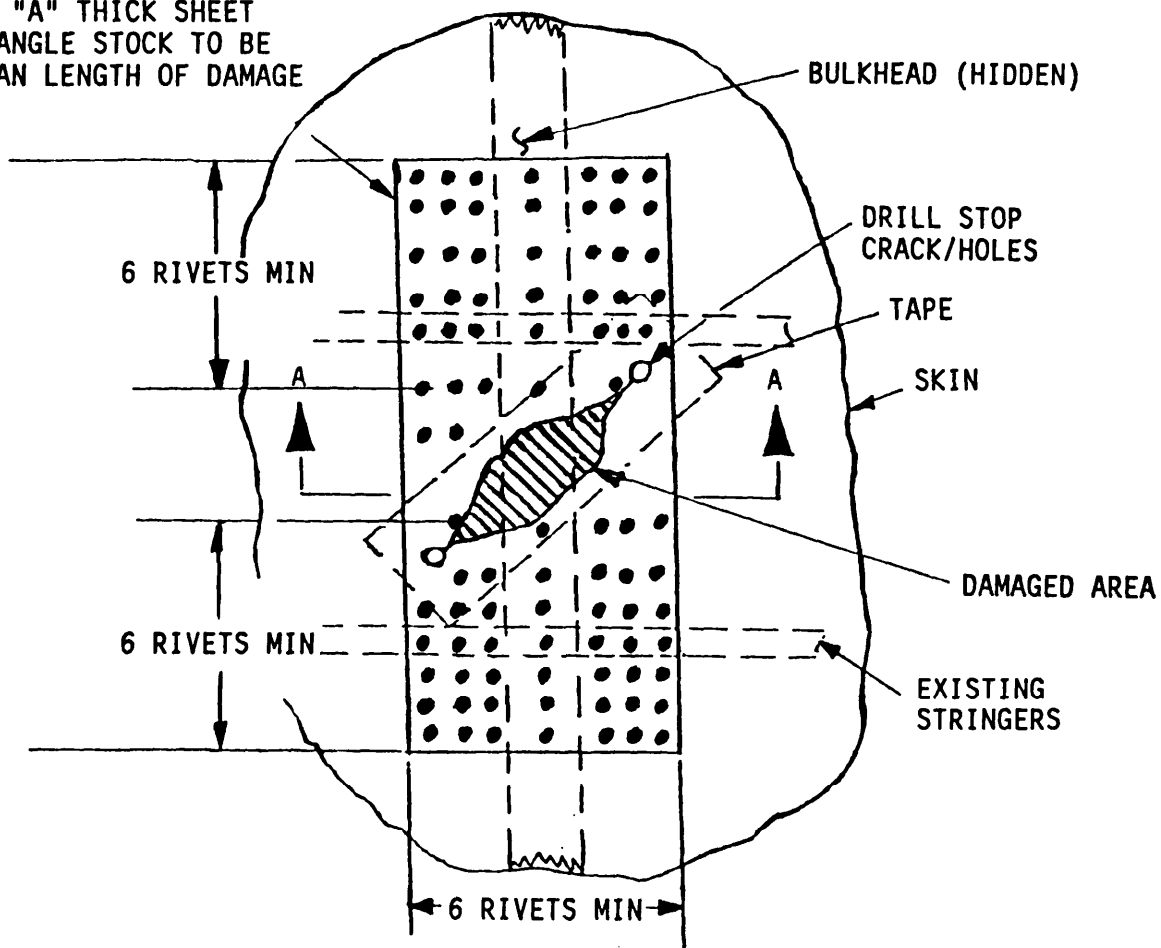

SECTION A-A

Figure 3-6. Repair of Damaged Bulkhed Flange (Sheet 1 of 2)

CHANNEL EXTRUSION OR
ANGLE STOCK TO BE LONGER
THAN LENGTH OF DAMAGE
PLUS LENGTH TO COVER 6
RIVET ROWS ON EACH END

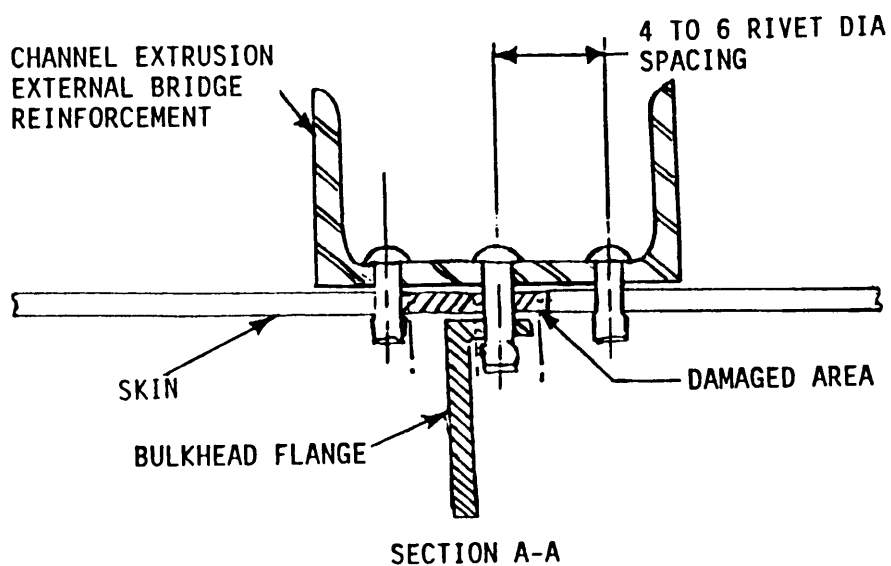
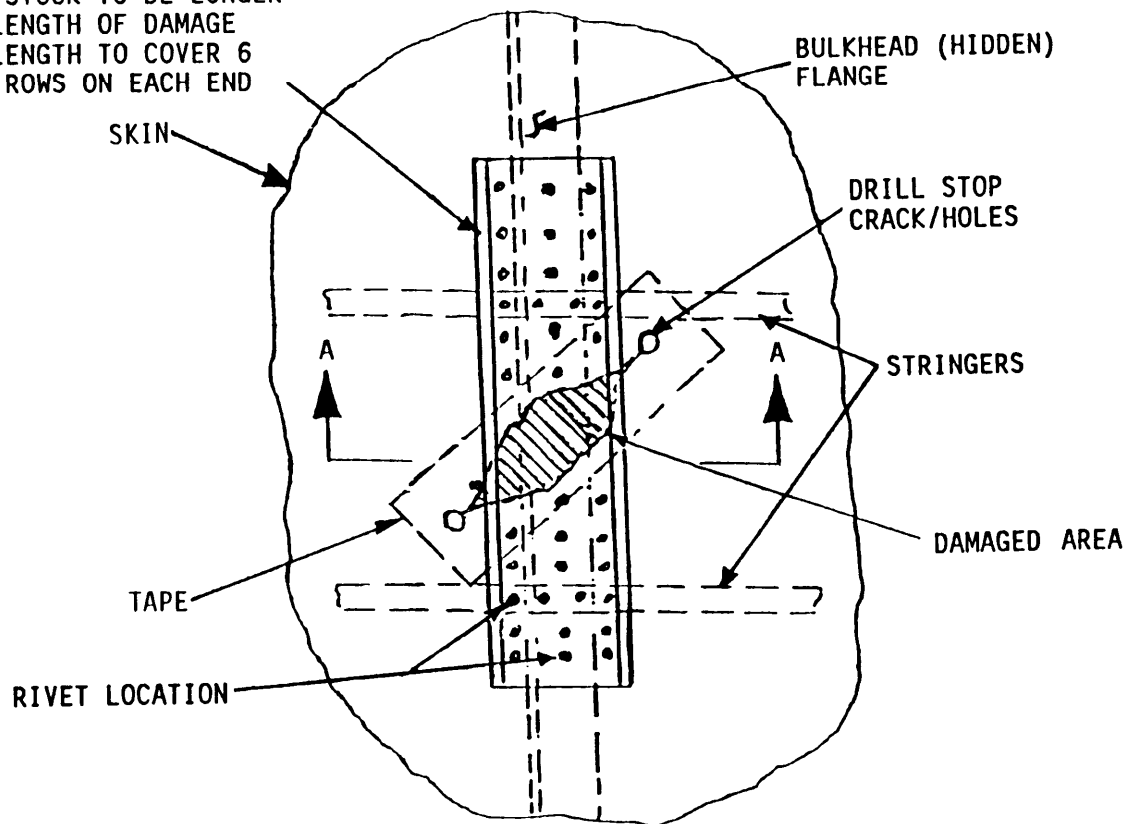

Figure 3-6. Repair of Damaged Bulhead Flange (Sheet 2 of 2)

Section VI. HONEYCOMB PANEL

3-13. GENERAL.

a. The UH-1 helicopter uses laminated honeycomb panels in numerous places. The cabin floor, the engine service deck, the main beams, and various other areas are constructed of bonded and laminated structures. These laminated panels are usually made up of a light-weight core sandwiched between two skins. The core material is normally a honeycomb metal or honeycomb material. The two outside skins can be either metal or composite fiberglass. Generally speaking, honeycomb panels stiffness comes from the external skin being held rigidly in one plane and fixed parallel to each other, resembling a solid element. Normally, they avoid any stiffness element within their boundaries, but require structural support around the edges.

b. This section will give various repairs and options depending on size of the damage, and in order of optional preference. Fixes in this section are designed to be expedient repairs to restore as much of original structure strength as possible without regards of weight or appearance.

c. Some of the repairs that follow are for damage to one side of skin. However, some of the repair procedures can be applied to both sides. The decision to repair both sides should be based on strength to be replaced and the time required to remove panel. The assessor will make this determination.

d. For permanent repairs on honeycomb panel, consult TM 55-1520-210-23.

3-14. HONEYCOMB PANELS, DAMAGED 2 INCH MAX DIA (THRU HOLE).

LIMITATIONS: Repair of both skins is optional.

PERSONNEL/TIME REQUIRED:

- 1 Soldier
- 10 Minutes

MATERIALS/TOOLS REQUIRED:

- Abrasive Grit Cloth (item 121, App C)
- Acetone Cleaner (item 1, App C)
- Aluminum Adhesive Tape (item 153, App C)
- Aluminum Sheet Metal 0.012/0.020 in. (item 130, App C)
- Epoxy, Five Minute (item 4, App C)
- Green Cotton Tape (item 156, App C)
- Chemical Conversion Coating (item 36, App C)

PROCEDURAL STEPS:

1. The following repair procedure will apply to one or both sides of panel as needed. Remove ragged edges using files and abrasive grit cloth, or push skin into void. Remove any paint, or at minimum roughen up the surface of the skin with 180 grit abrasive cloth around the damaged area. This bonding area around hole should be two to three inches wide.
2. Clean the reworked area with acetone or any equivalent fast drying cleaner. To improve adhesion, treat aluminum with chemical conversion coating (alodine).
3. Prepare a thin piece of aluminum (0.012 to 0.020 inch thick) to cover the damage in the skin and to extend 1-1/2 inches past the damage. Treat aluminum with chemical conversion coating.
4. Coat the aluminum patch and the skin in the area around the damage in skin with quick five minute drying epoxy. If no epoxy is available, cover the damaged area with either green cotton tape or aluminum adhesive tape.
5. Repeat steps 1 thru 4 for the other side of panel if accessible or needed.

6. Record BDAR action taken. When mission is complete, as soon as practical, repair the equipment/system using standard maintenance procedures.

3-15. HONEYCOMB PANELS, DAMAGED 2 TO 8 INCHES IN DIAMETER.

OPTION 1: One Skin and Core Damaged.

LIMITATIONS: This repair is limited to damaged panels with metal skins.

PERSONNEL/TIME REQUIRED:

- 1 Soldier
- 45 Minutes

MATERIALS/TOOLS REQUIRED:

- Abrasive Grit (item 121, App C)
- Acetone Cleaner (item 1, App C)
- Aluminum Sheet Metal 0.012/0.020 in. (item 130, App C)
- Cherry Rivets (items 94-114, App C)
- Epoxy, Five Minute (item 4, App C)
- Hand Rivet Puller (items 147-150, Sec II, App B)
- Chemical Conversion Coating (item 36, App C)

PROCEDURAL STEPS:

1. Remove damaged skin if it is loose; otherwise, push damaged skin into the void, Figure 3-7. The maximum damage that may be cutout or damaged is 8 inches in diameter. Use abrasive grit cloth to roughen up the surface of metal in a 3 inch wide band around the damage/hole.

2. Make a patch plate from aluminum sheet metal twice as thick as the original external skin metal. Plate dimensions are to be the same size of the hole plus a 2-1/2 inch rivet and adhesive border around the damage.

3. Lay out and drill a rivet pattern on patch and on the damaged panel. Rivet spacing to be 1 to 1-1/2 inches. Bolts

may be used in place of rivets. When bolt, washer, and nuts are used, drilling all the way through panel's both skins will be required. Care should be used when tightening the bolts, so as not to crush the panel.

4. Clean the patch plate, the void, and the repair area on skin with acetone. Treat bare aluminum with chemical conversion coating to improve adhesion.

NOTE

Epoxy hardens in five minutes. Be prepared, work fast, and line up rivet holes with at least four Cleco clamps or rivets.

5. Coat the patch plate and the damage panel repair area with adhesive. Place the patch in place, lining up the rivet holes with rivets or bolts.

6. Immediately rivet the patch plate in place with cherry rivets or install bolts.

7. Record BDAR action taken. When mission is complete, as soon as practical, repair the equipment/system using standard maintenance procedures.

3-16. HONEYCOMB PANELS, DAMAGED UP TO 12 BY 12 INCHES THROUGH PANEL.

LIMITATIONS: None.

PERSONNEL/TIME REQUIRED:

- 1 Soldier
- 1-1/2 Hour

MATERIALS/TOOLS REQUIRED:

- Abrasive Grit (item 121, App C)
- Acetone Cleaner (item 1, App C)
- Aluminum Patch Plates (items 129-141, App C)
- Cherry Rivets (item 112, App C)
- Hand Rivet Puller (items 147-150, Sec II, App B)

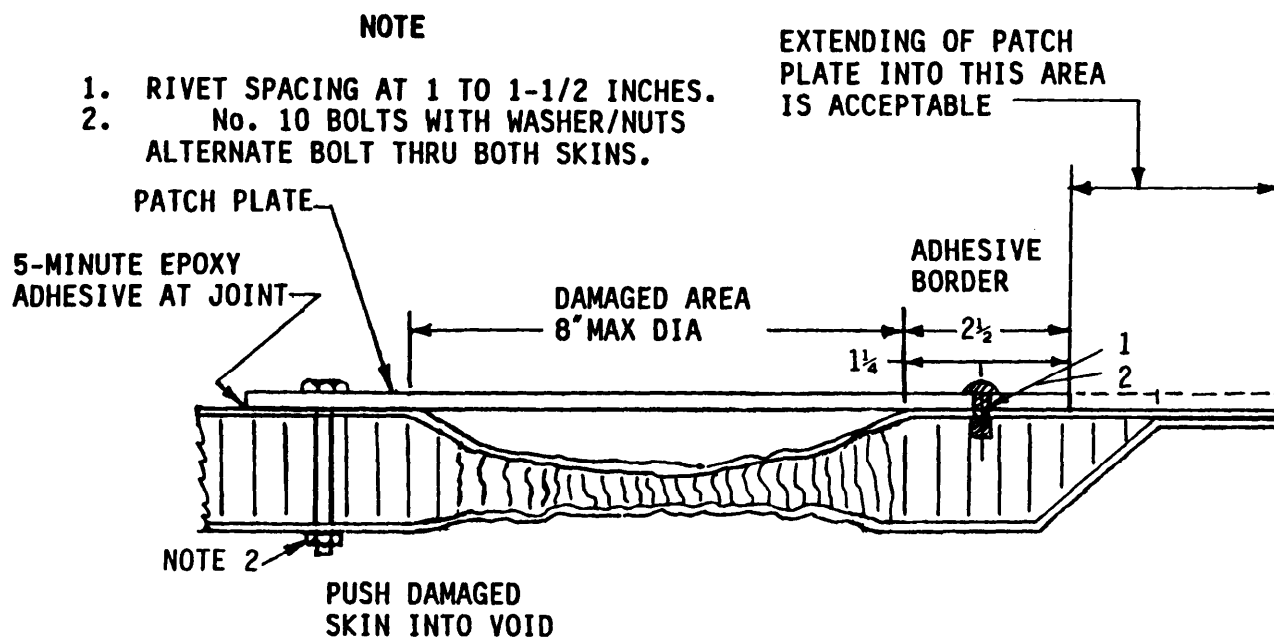

Figure 3-7. Honeycomb Panel Repair

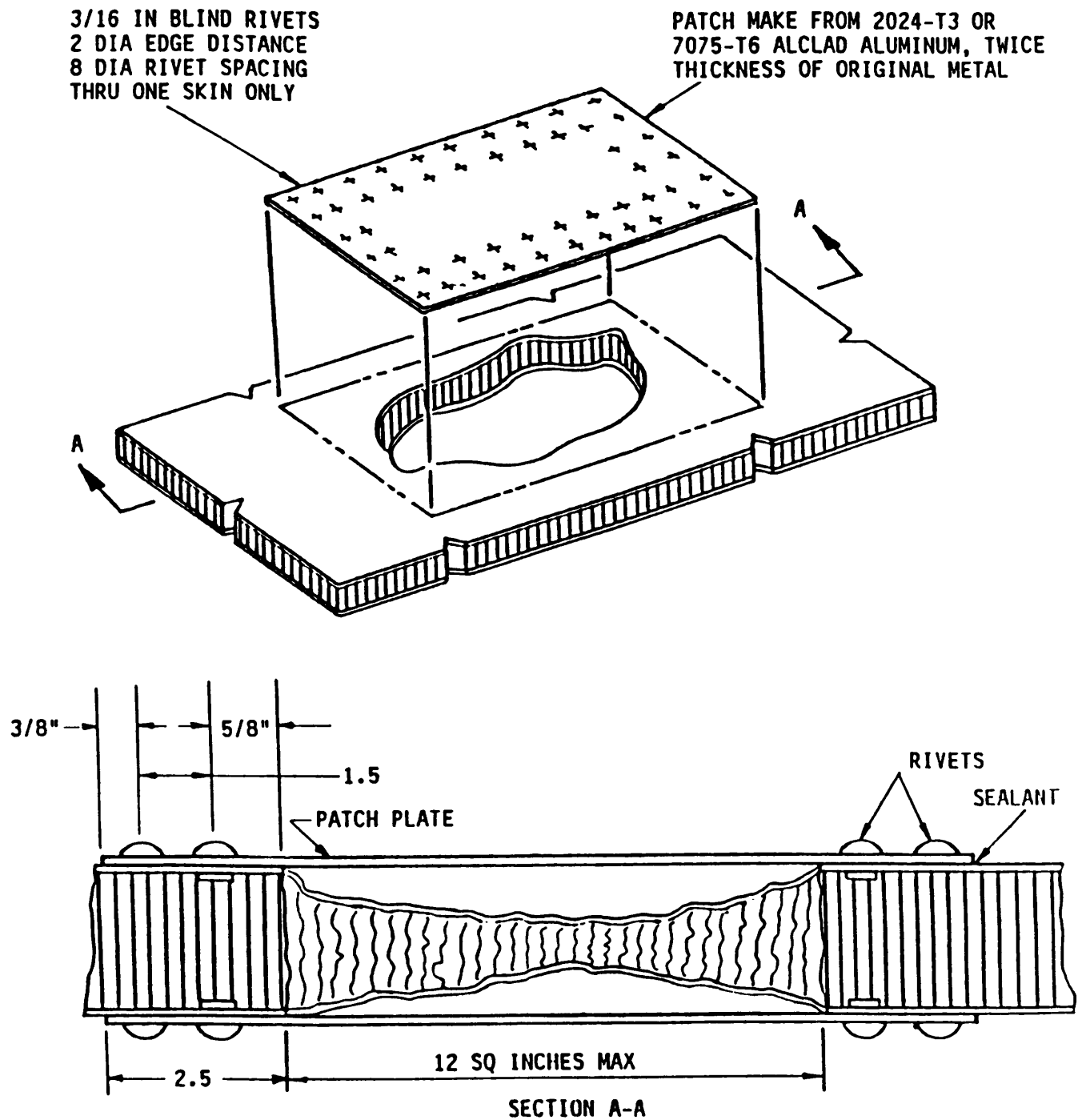

Figure 3-8. Repair of Honeycomb Core Panel - Damage up to 12 X 12 Inches - Both Skins and Core

PROCEDURAL STEPS:

1. Remove damaged skin if it is loose; otherwise, push damaged skin into the core/void, Figure 3-8. The maximum damage allowed is 144 square inches. Use abrasive grit cloth and a file to remove burrs.

2. Make two patch plates from aluminum sheet metal twice as thick as the original metal. Plate dimensions are to be as shown in Figure 3-8. If time is available and panel can be unbolted, remove panel to repair if damage is inaccessible on interior skin. If panel cannot be removed, then consider installing a single patch plate on the accessible side, making the patch plate of metal three times the thickness of original metal thickness.

3. Lay out and drill a double row rivet pattern on patch and on the damaged panel. Rivet spacing to be as shown in Figure 3-8. Bolts (No. 10) may be used in place of rivets if backside area is accessible for wrenches. When bolt, washer, and nuts are used, drilling all the way through panel's both skins will be required. Care should be used when tightening the bolts so as not to crush the panel.

4. Rivet the patch plate in place with cherry rivets or install bolts.

5. Record BDAR action taken. When mission is complete, as soon as practical, repair the equipment/system using standard maintenance procedures.

Section VII. LOW PRESSURE HOSES AND METAL TUBING

3-17. **GENERAL.** The UH-1 helicopter has four low pressure plumbing systems. These systems are connected with flexible hoses and rigid metal tubing. Damage sustained in battle can cause leaks which must be repaired to maintain flyability. These four systems are engine oil, transmission oil, fuel, and bleed air. The fluids and compressed air that flow through these systems must be contained and, in a case of leaks, repaired as soon as possible. The expedient repair in this section is for small holes or cracks in low pressure fluid/gas lines and is not intended to be used to repair a ruptured high pressure line exceeding 100 psi.

3-18. LOW PRESSURE HOSES AND METAL TUBING, LEAKING.

LIMITATIONS: Inspect the repaired line before and after each flight. Constant monitoring of system instruments for overheating or low pressure.

PERSONNEL/TIME REQUIRED:

- 1 Soldier
- 15 Minutes
- 60 Minutes (full adhesive cure time)

MATERIALS/TOOLS REQUIRED:

- Acetone or Equivalent Solvent Cleaner (item 1, App C)
- Adhesive Repair Kit (Zip-Patch kit) (item 5, App C)

PROCEDURAL STEPS:

CAUTION

Zip-Patch and adhesive activator are flammable. Keep away from heat and flames. Use in a well-ventilated area. Avoid contact with skin and eyes. Use protective gloves and glasses.

1. Remove pressure from the line to be repaired. Drain fluids and make sure there are no fluids flowing from the damage area.

2. Locate the damaged area and clean off dirt and oil film with clean cloths soaked in solvent. Repair area must be absolutely clean for the patch to adhere properly.
3. The Zip-Patch kit contains five patches in sealed foil packages, activator spray can, gloves, and an applicator plastic tool.
4. Spray one side of patch lightly with activator. Proper activation will be indicated by the patch becoming darker in color. Spray the damaged area lightly with activator.
5. Place the activated side of the patch over the damaged area and extending two to four inches beyond the damage. Wrap the patch around the hose or tube until the repair area is covered. Smooth the patch with the plastic spreader tool to remove any entrapped air.
6. Spray the exposed area of the patch lightly with the activator.
7. Wait five minutes for Zip-Patch to set. Full cure is reached in one hour.
8. Refill system with fluid that was lost or was drained prior to repair.
9. Record BDAR action taken. When mission is complete, as soon as practical, repair the equipment/system using standard maintenance procedures.

CHAPTER 4

AIRFRAME

BDAR FIXES SHALL BE USED ONLY IN COMBAT OR FOR TRAINING
AT THE DISCRETION OF THE COMMANDER.
(AUTHORIZED TRAINING FIXES ARE LISTED IN APPENDIX E.)
IN EITHER CASE, DAMAGES SHALL BE REPAIRED BY STANDARD
PROCEDURES AS SOON AS PRACTICABLE.

Section I. INTRODUCTION

4-1. SCOPE.

a. The purpose of this chapter is to provide BDAR to the damaged UH-1 helicopter airframe structure. The repairs are intended to repair damage which has degraded or will degrade in a short period of time the flight capabilities of the helicopter.

b. The helicopter airframe structure can be classified as follows:

(1) Primary load carrying structure. Longerons, caps, stringers, firewalls, and bulkheads are examples of primary structures. See Figure 4-1 for a view of the primary structures of the UH-1 helicopter.

(2) Secondary diffused load carrying and transferring structure. Skins, laminated panels, and doors are examples of secondary structure. See Figure 4-2 for a complete view and listing of the helicopters outside skin.

c. Battle damage to the airframe structure is not always evident from the flight characteristics of the aircraft. If damage occurred in flight, landing may be necessary. The only way to assess battle damage to the airframe is through visual inspection of the aircraft.

d. During the initial assessment, the following should be recognized:

(1) Some primary damage/repair may be deferred.

(2) Most secondary damage/repair can be deferred.

(3) All BDARs will be temporary.

(4) Repairs must contribute to and improve some "lost function" of helicopter to as close to 100 percent of its intended function as possible under BDAR conditions.

(5) Repairs must work without regards to weight, appearance, or aerodynamic appeal.

(6) Repair must be simple and quick in application.

(7) Repair must improve the damaged helicopters flight or mission capability or at minimum, repair must allow for helicopter's self-recovery.

e. This chapter will be arranged by sections, with each section of the helicopter being assessed by a section in this chapter. BDAR fixes are listed in the repair procedure index, paragraph 4-3. Figures 4-1 and 4-2 are to be used to locate and identify damage to the helicopter.

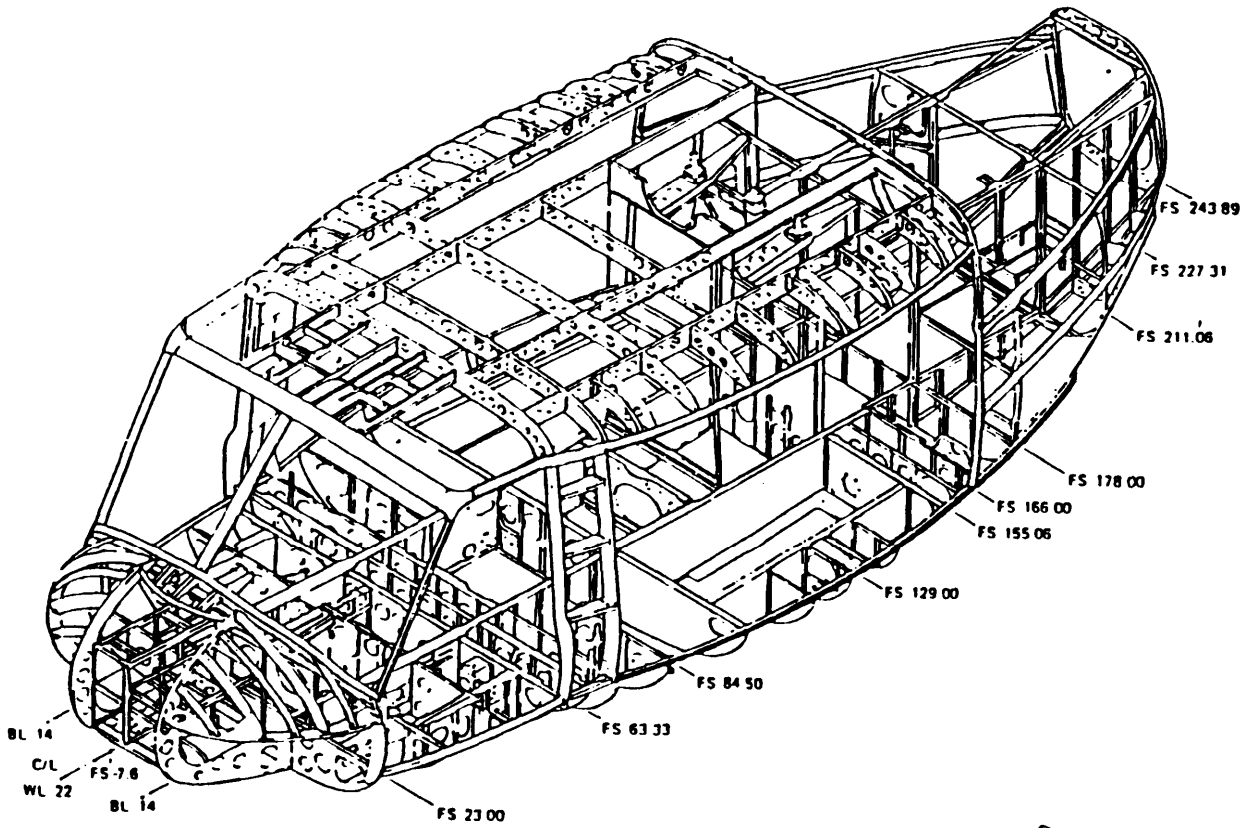

**FORWARD FUSELAGE
 PRIMARY STRUCTURE**

FUSELAGE STATION = FS
 BUTTLINE = BL
 WATERLINE = WL
 BOOM(TAIL) STATION = BS
 CENTERLINE = CL
 FIN STATION = FNS

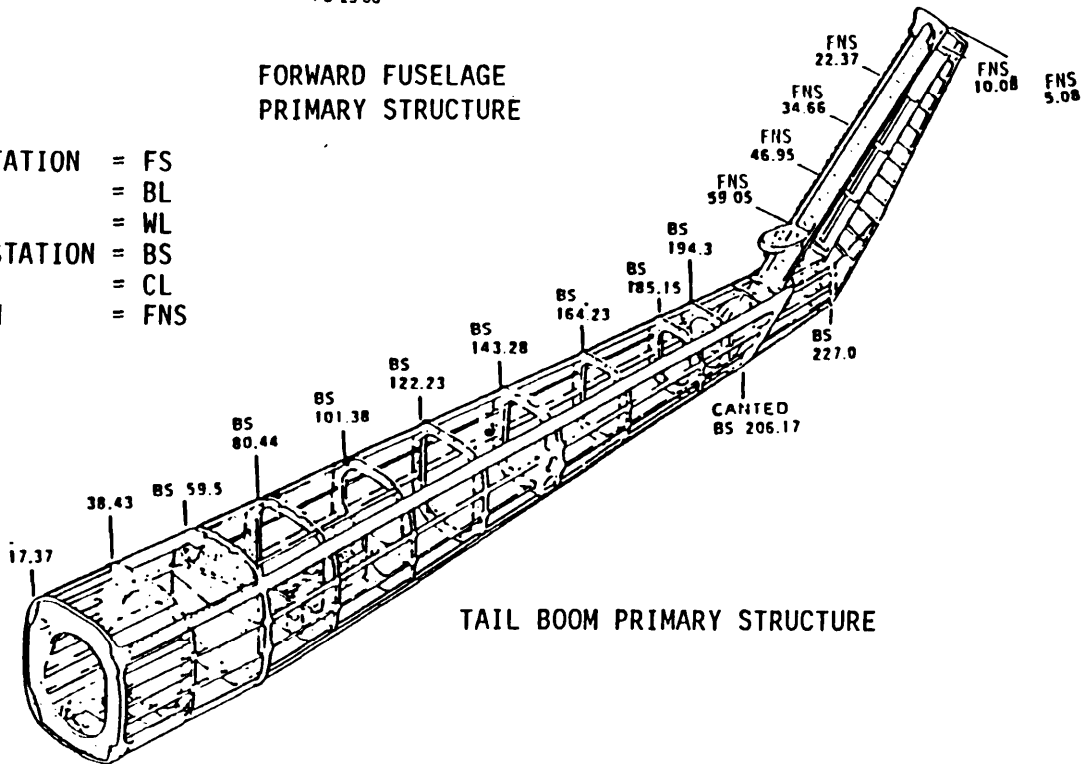

TAIL BOOM PRIMARY STRUCTURE

Figure 4-1. Fuselage Structure, Station, Water, and Butt Lines (Sheet 1 of 15)

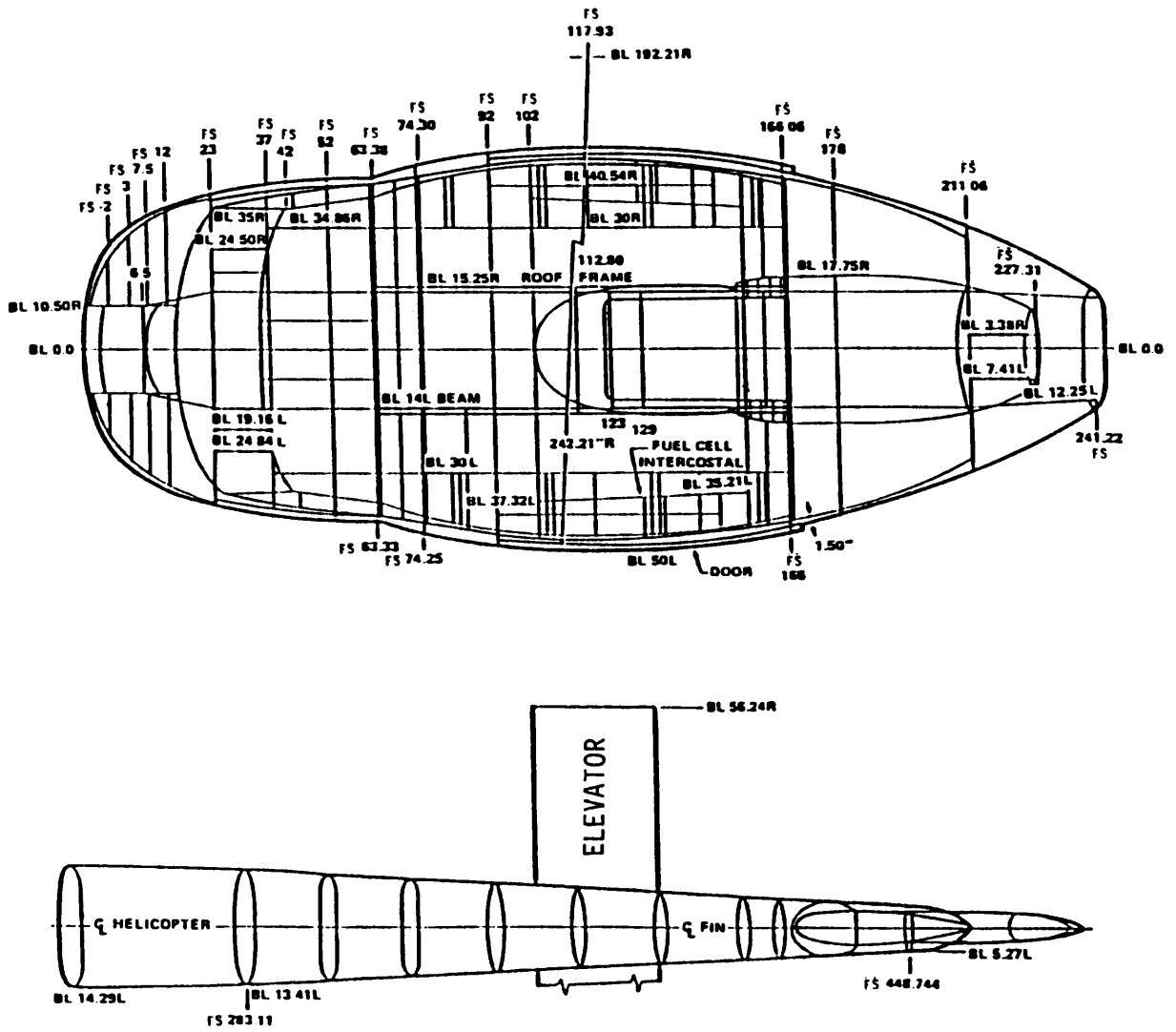

Figure 4-1. Fuselage Structure, Station, Water and Butt Lines (Sheet 2 of 15)

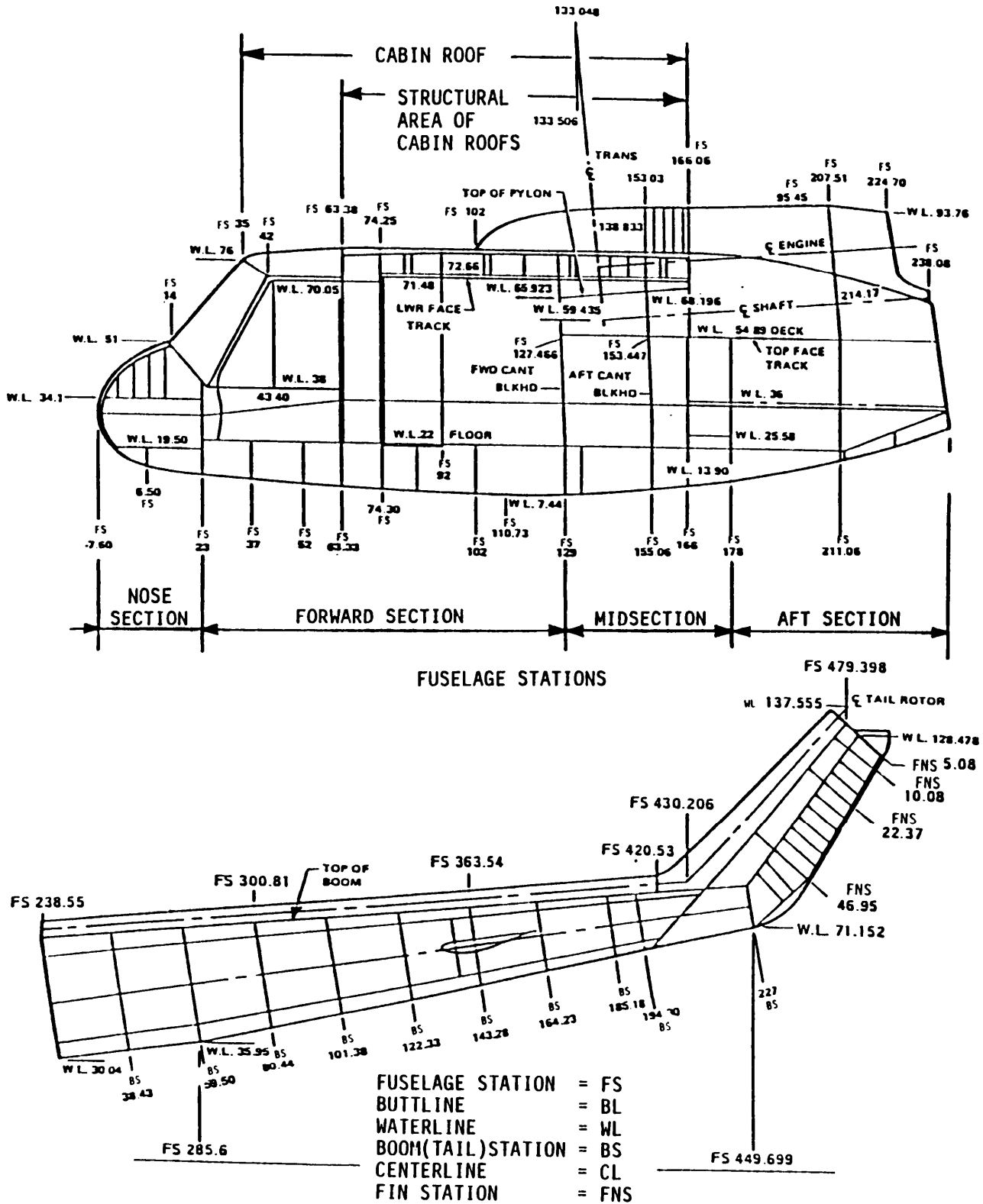

Figure 4-1. Fuselage Structure, Station, Water, and Butt Lines (Sheet 3 of 15)

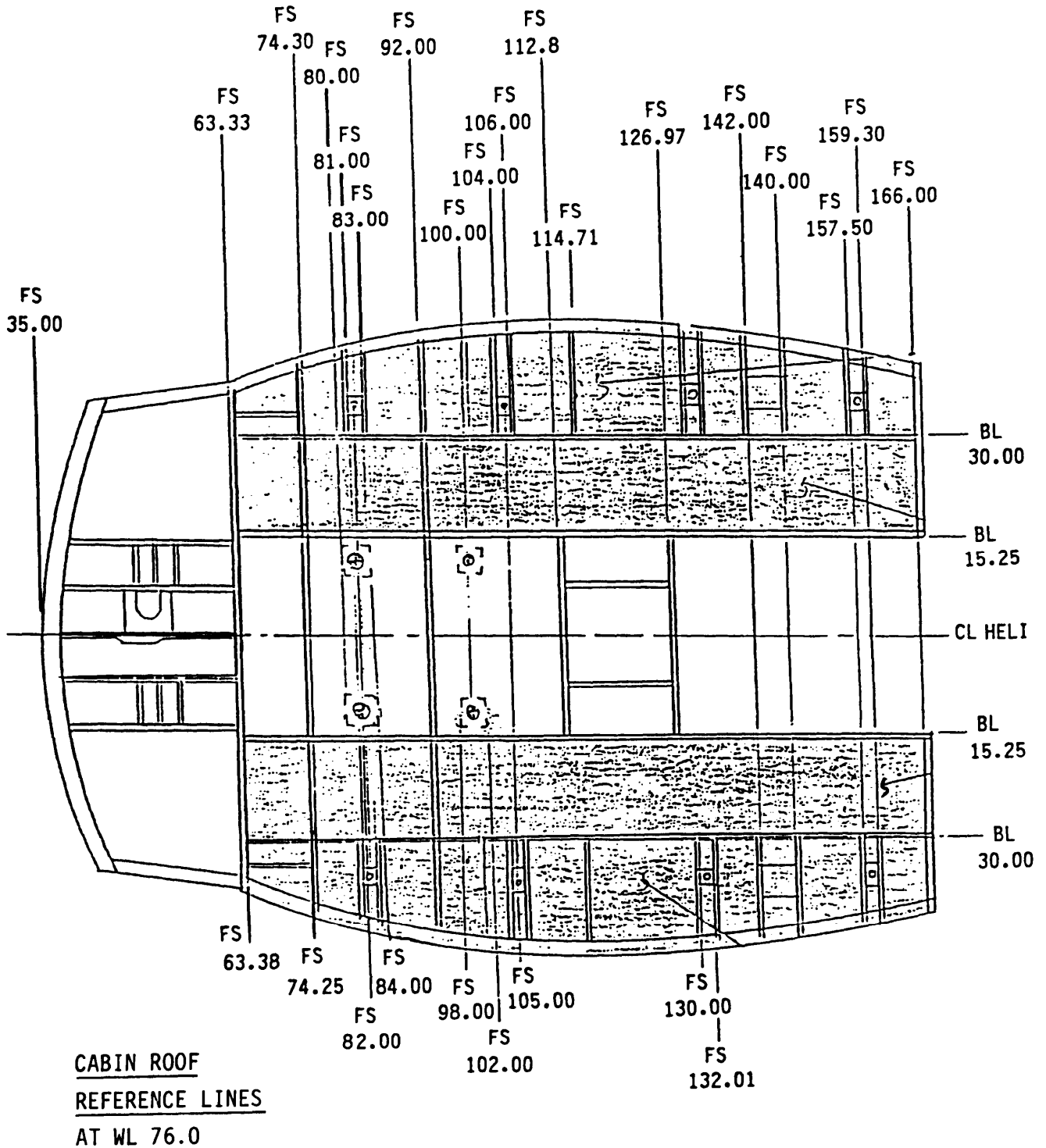
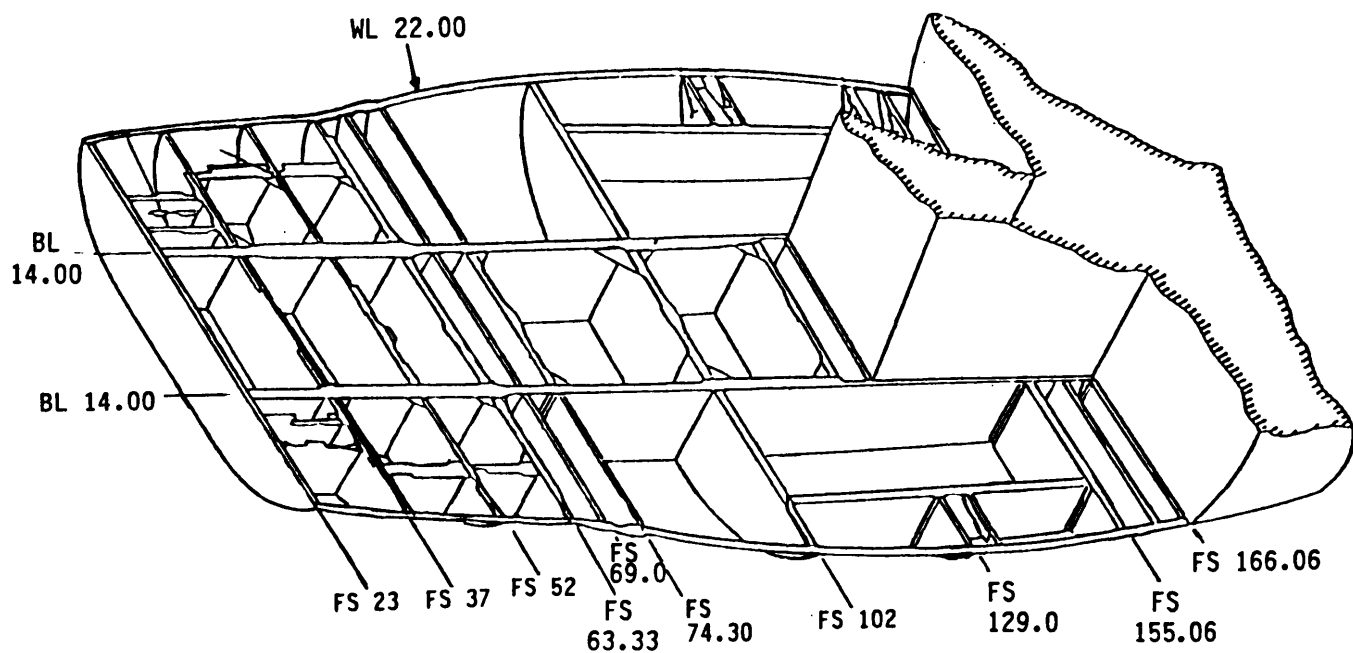

Figure 4-1. Fuselage Structure, Station, Water and Butt lines (Sheet 4 of 15)



CABIN FLOOR (WL 22.00) AND
SUB-STRUCTURE REFERENCE LINES

Figure 4-1. Fuselage Structure, Station, Water,
and Butt Lines (Sheet 5 of 15)

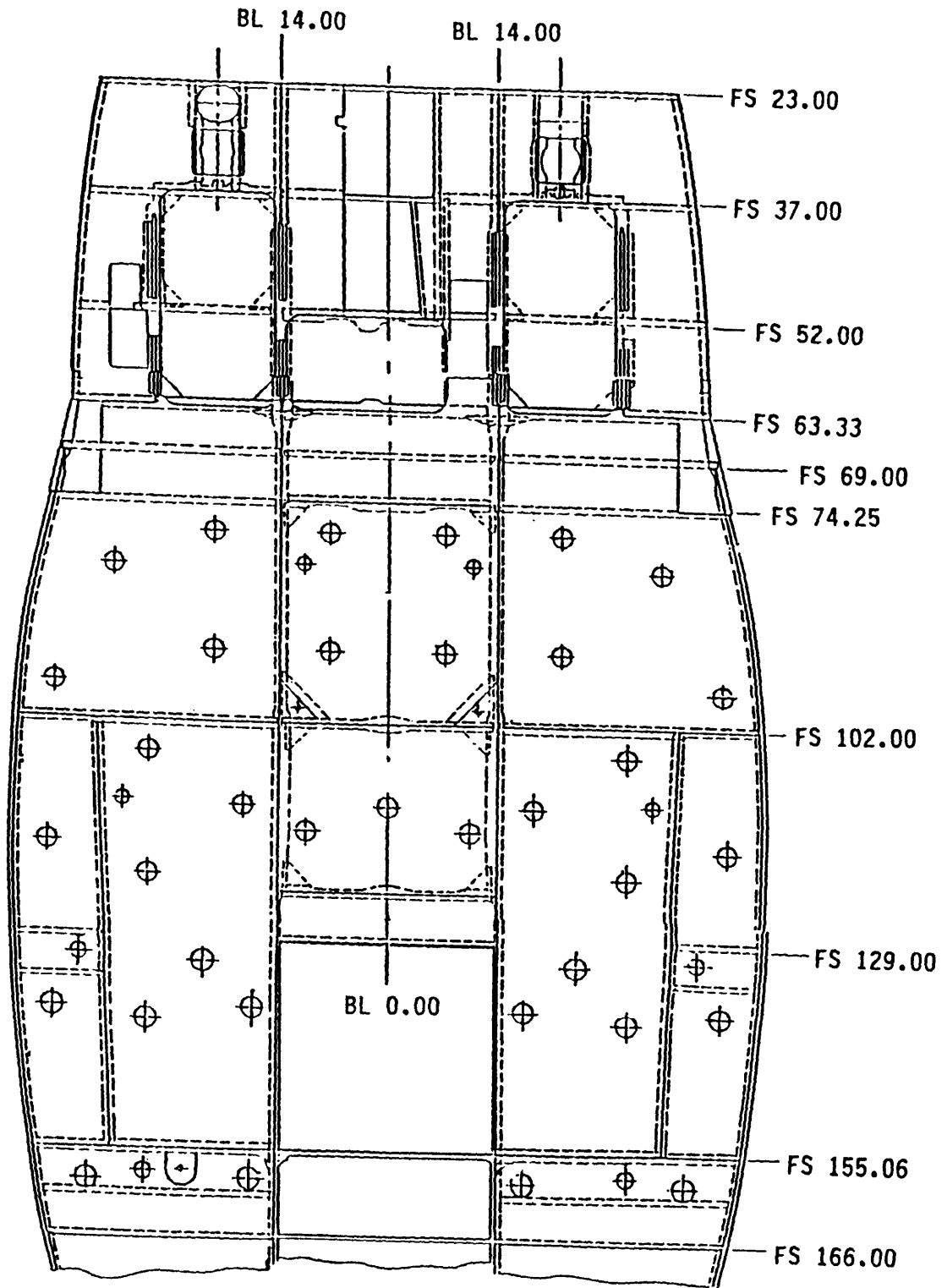

Figure 4-1. Fuselage Structure, Station, Water and Butt Lines (Sheet 6 of 15)

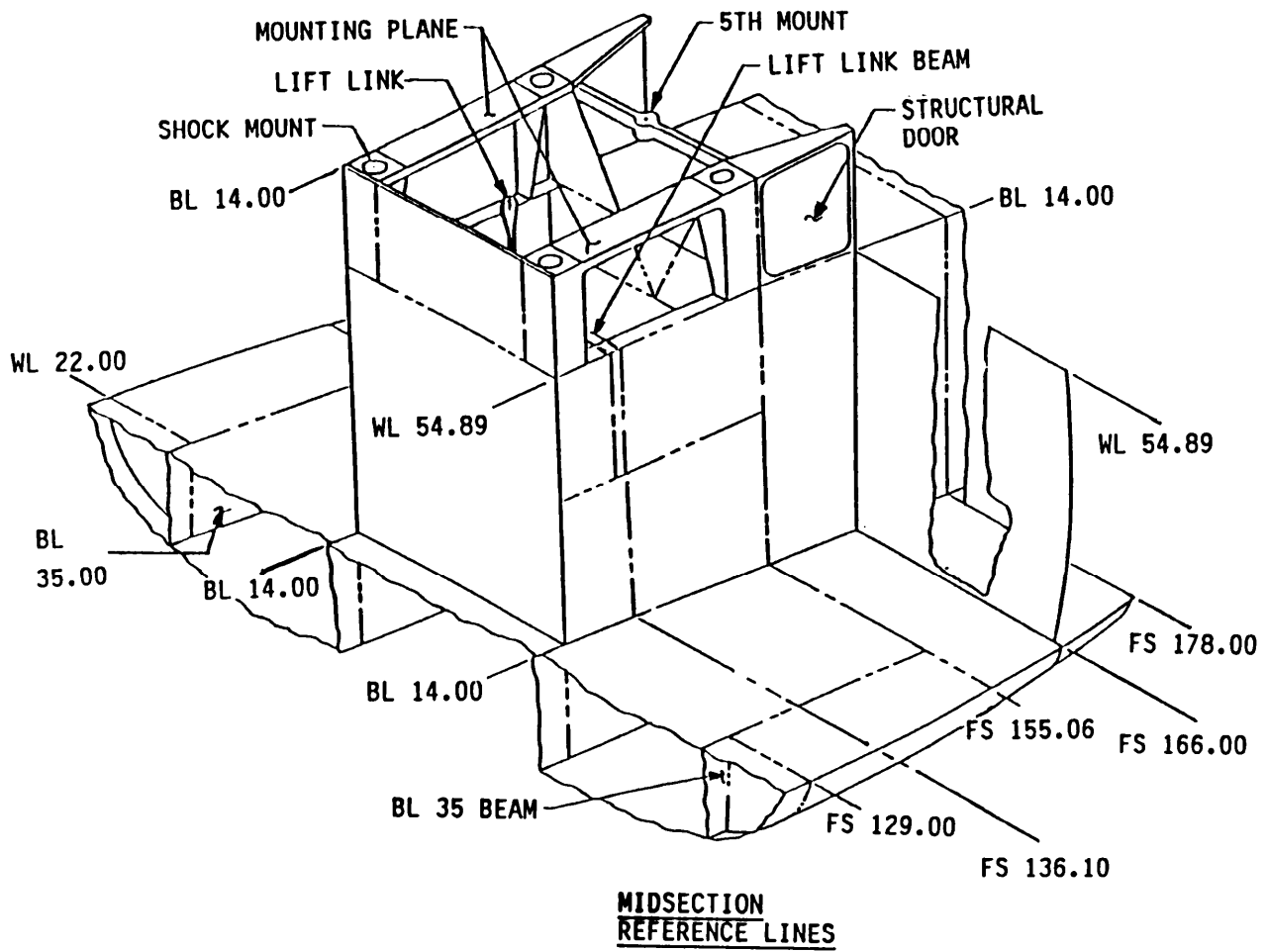

Figure 4-1. Fuselage Structure, Station, Water, and Butt Lines (Sheet 7 of 15)

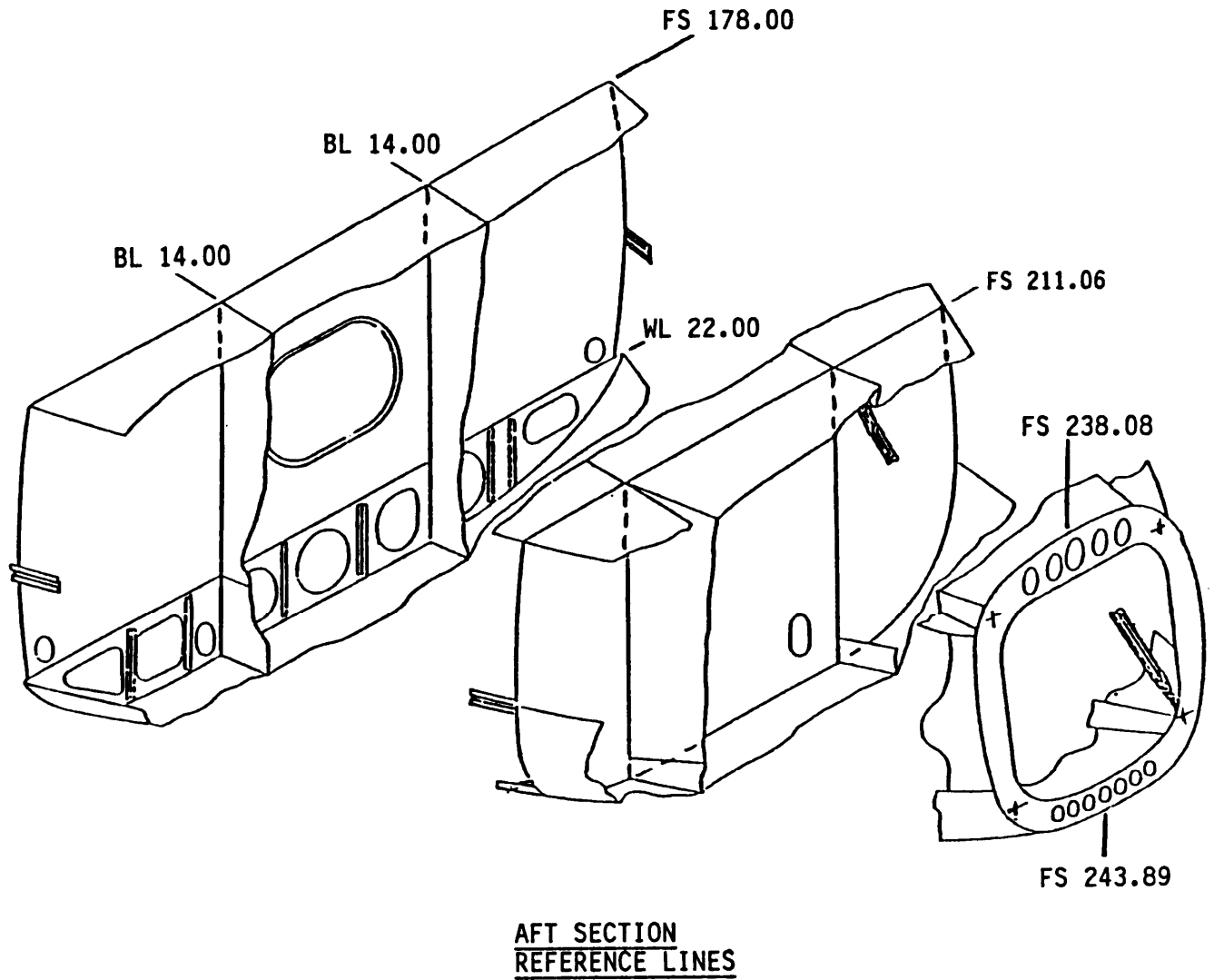

Figure 4-1. Fuselage Structure, Station, Water and Butt Lines (Sheet 8 of 15)

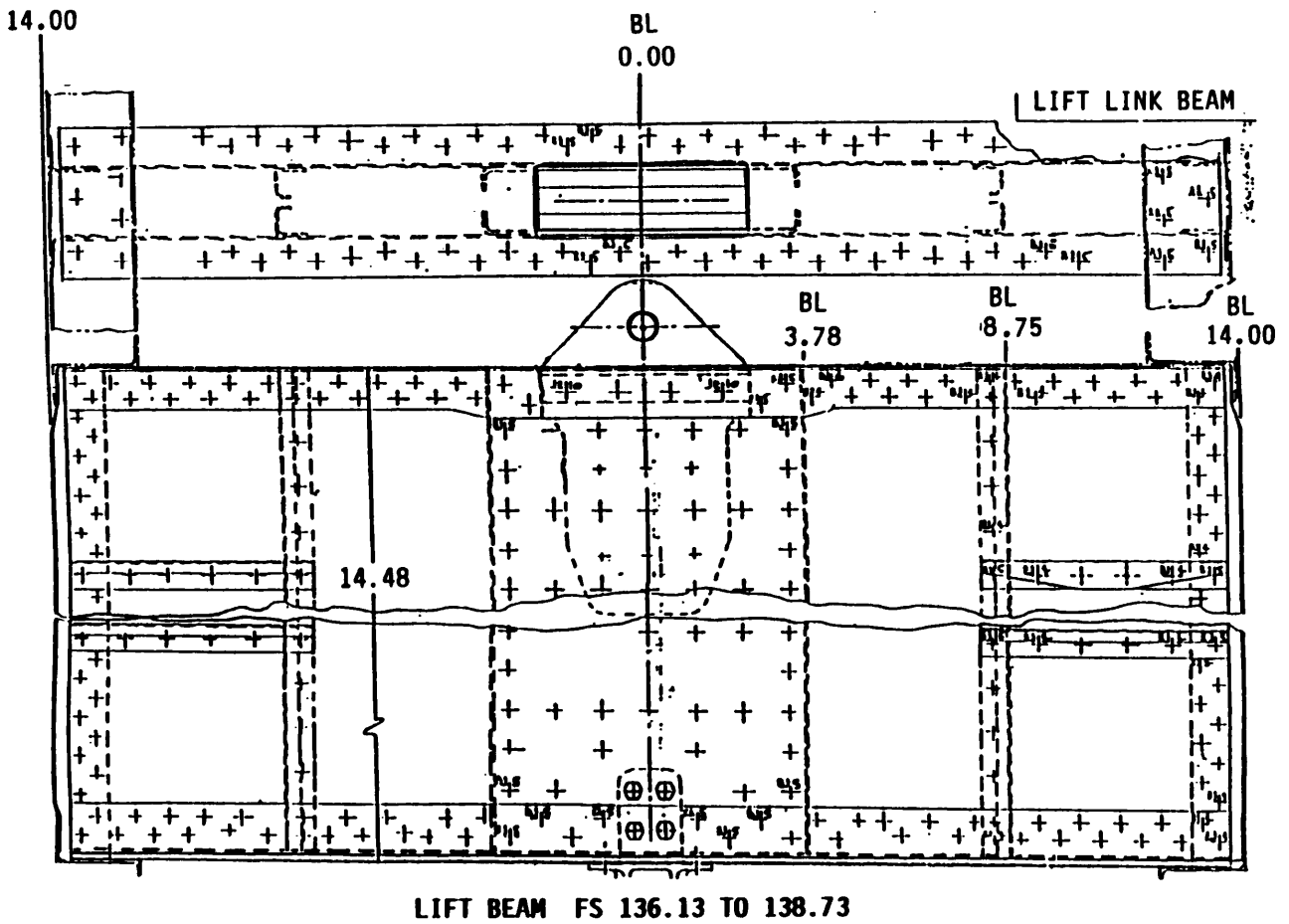

Figure 4-1. Fuselage Structure, Station, Water, and Butt Lines (Sheet 9 of 15)

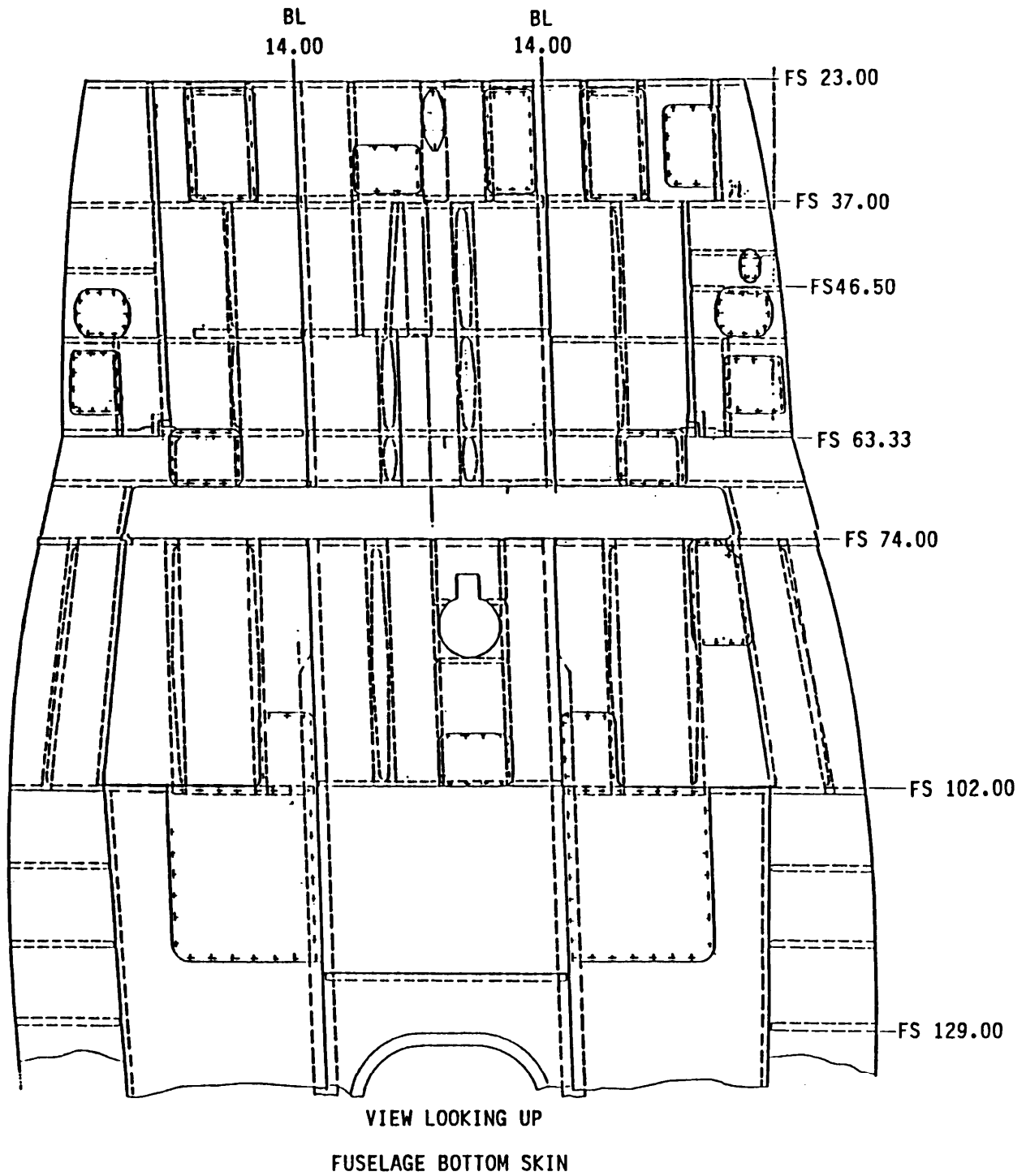

Figure 4-1. Fuselage Structure, Station, Water and Butt Lines (Sheet 10 of 15)

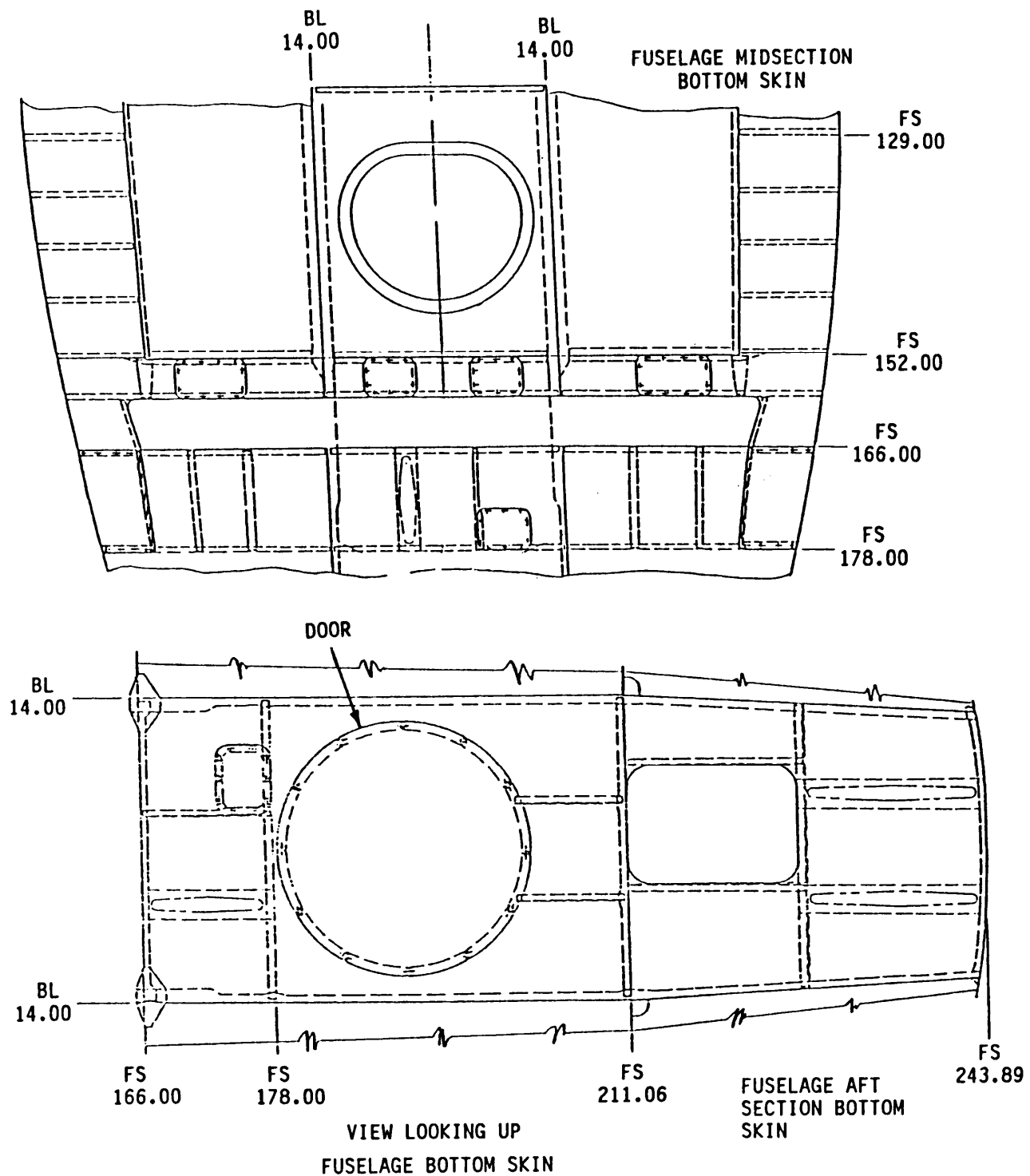

Figure 4-1. Fuselage Structure, Station, Water, and Butt Lines (Sheet 11 of 15)

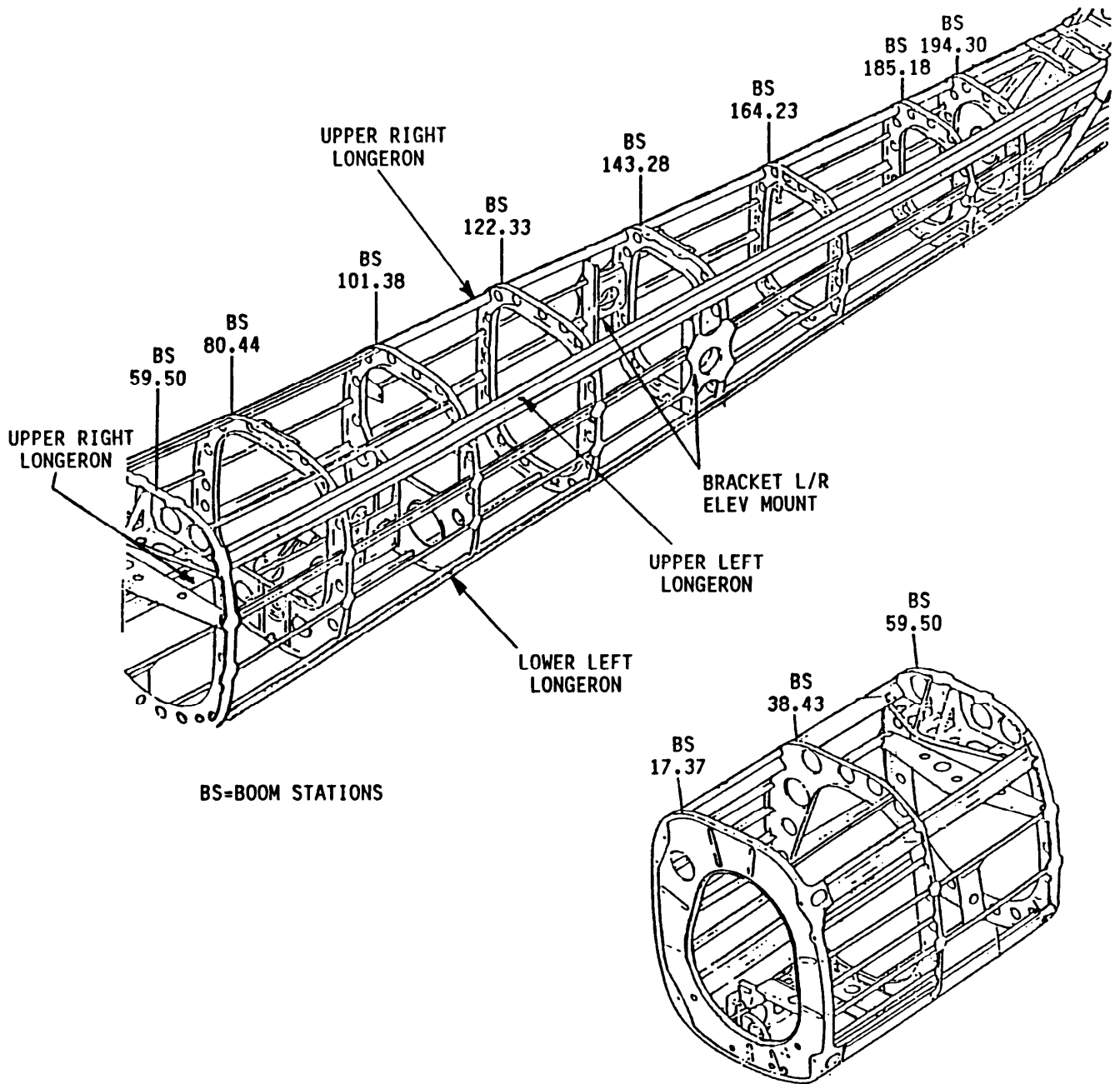

Figure 4-1. Fuselage Structure, Station, Water and Butt Lines (Sheet 12 of 15)

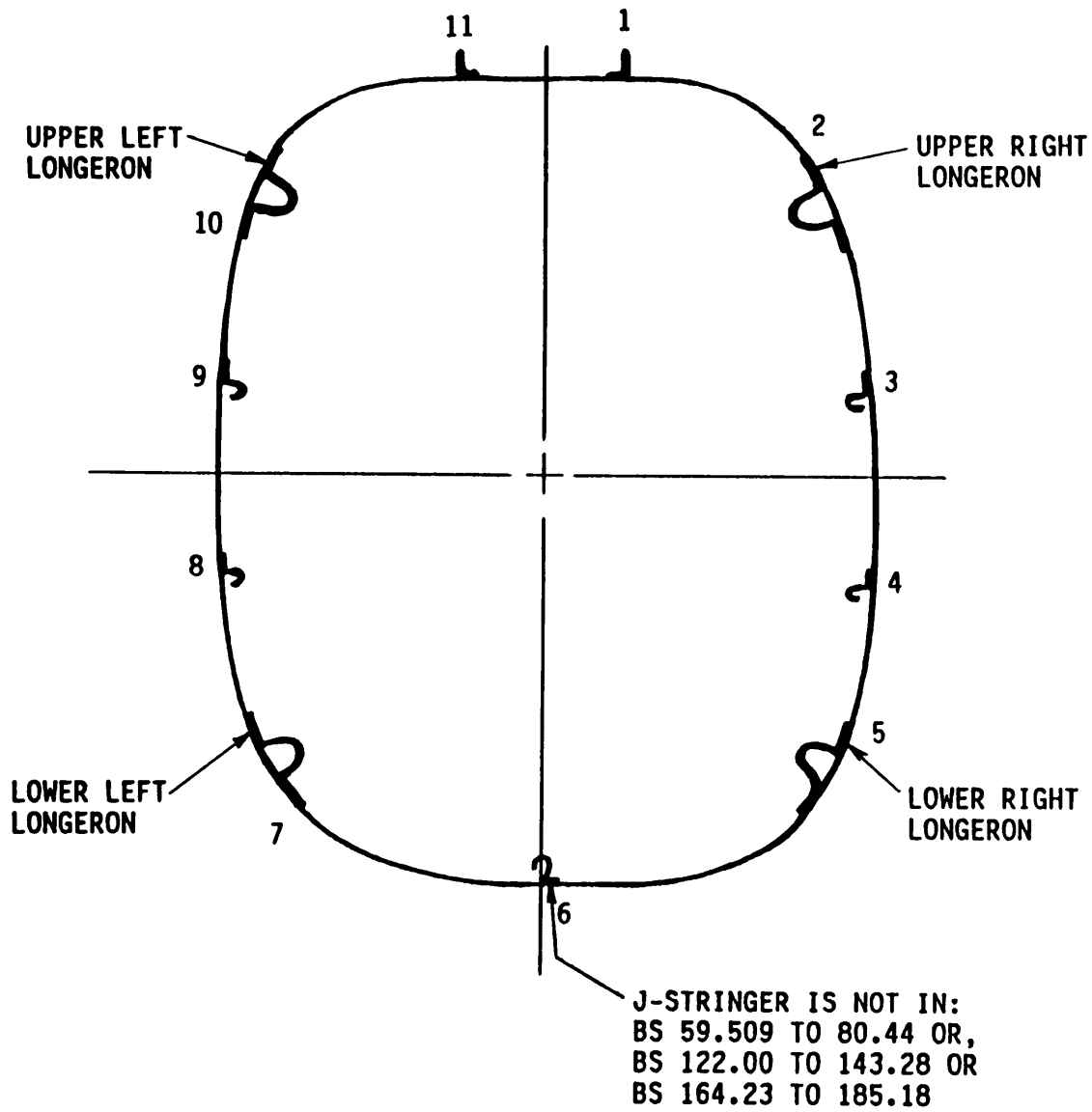

Figure 4-1. Fuselage Structure, Station, Water, and Butt Lines (Sheet 13 of 15)

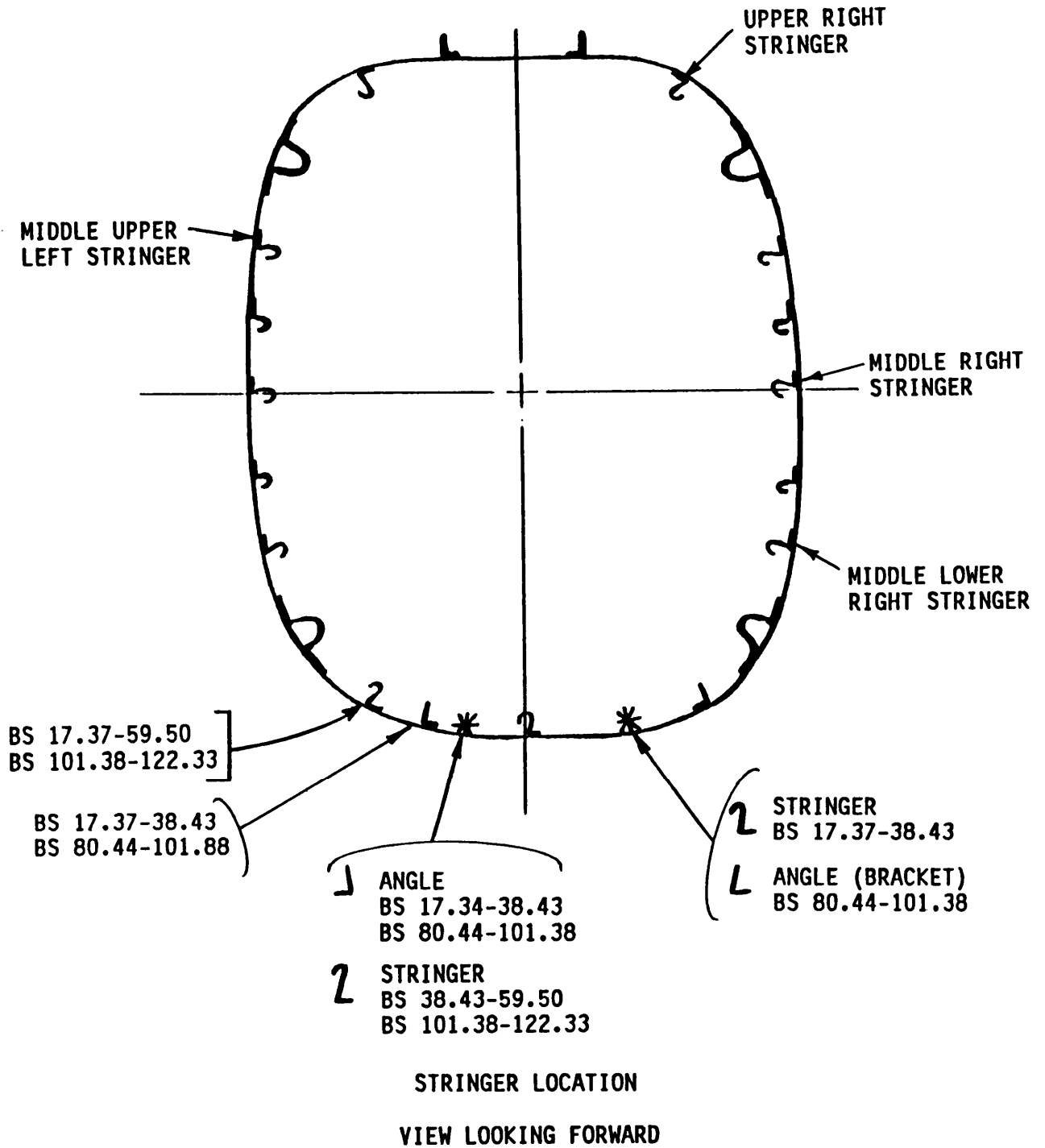
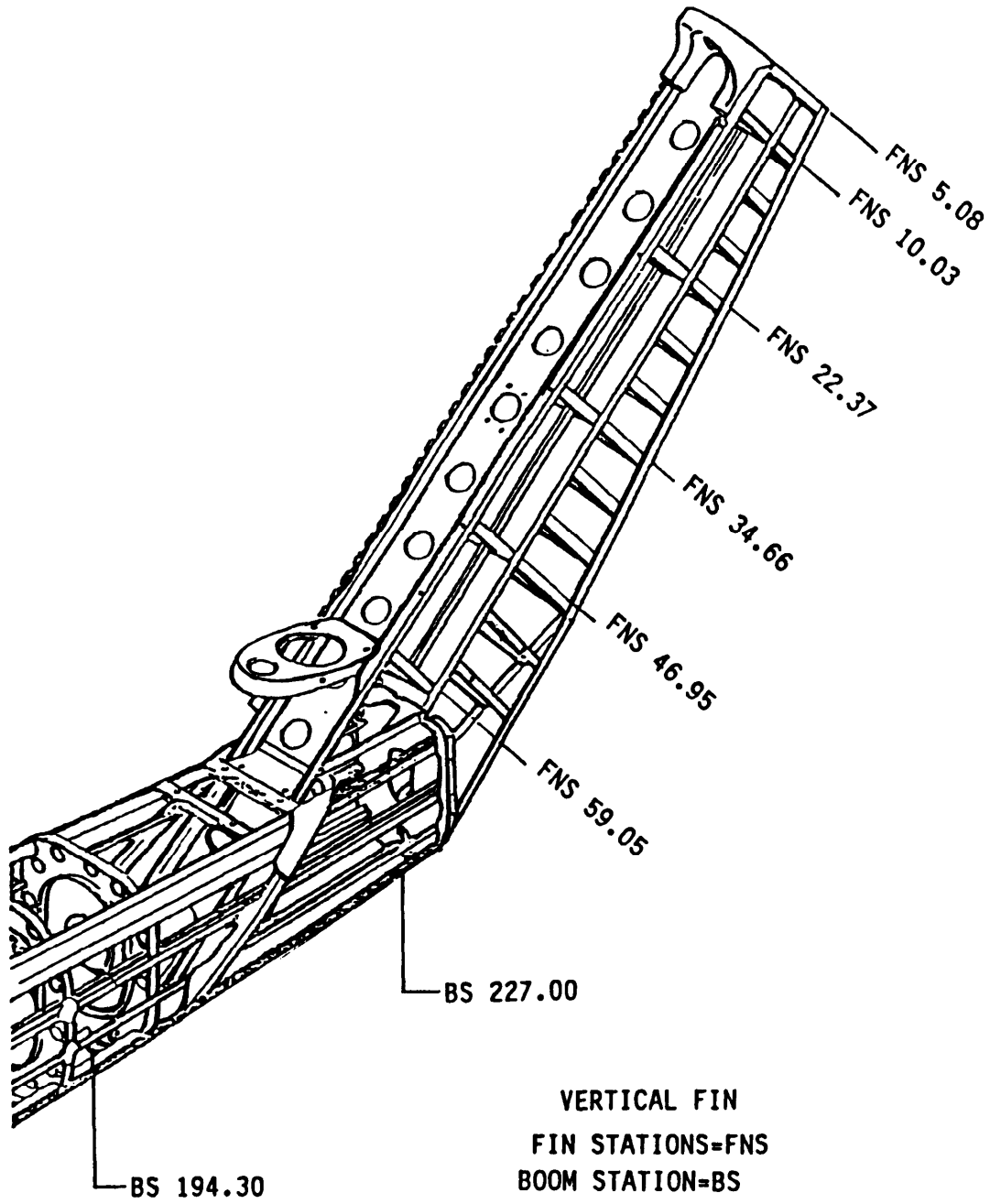

Figure 4-1. Fuselage Structure, Station, Water and Butt Lines (Sheet 14 of 15)



TAIL BOOM

Figure 4-1. Fuselage Structure, Station, Water, and Butt Lines (Sheet 15 of 15)

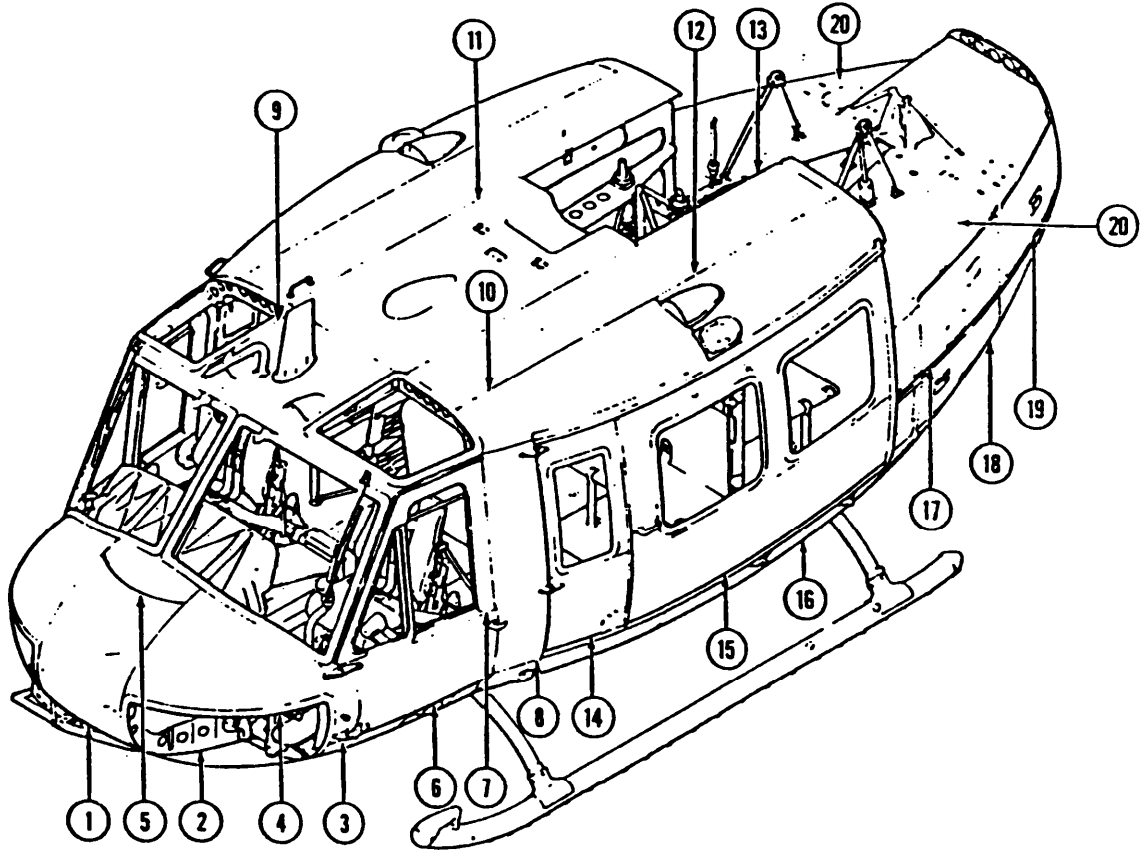

Figure 4-2. Forward Fuselage Skin (Sheet 1 of 6)

Item	Name	Material	Specification	Condition	Thickness
1	Nose door	Fiberglass	Type C	—	—
2	Nose door	Al Honeycomb	MI L-C-7438	—	0.250
	Nose, lwr fwd	Al Aly	QQ-A-250/5	T42	0.020
3	Side, fwd LH	Al Aly	QQ-A-250/6	T42	0.032
	Side, fwd RH	Al Aly	QQ-A-250/5	T42	0.032
4	Side, upper LH	Al Aly	QQ-A-250/6	T42	0.020
	Side, upper RH	Al Aly	QQ-Q-250/5	T42	0.020
5	Center, upper	Al Aly	QQ-A-250/5	T42	0.020
6	Door, lwr LH	Al Aly	QQ-A-250/5	T4	0.025
	Door, lwr RH	Al Aly	QQ-A-250/5	T4	0.025
7	Door, upper LH	Al Aly	QQ-A-250/5	T4	0.025
	Door, upper RH	Al Aly	QQ-A-250/5	T4	0.025
8	Post, LH	Al Aly	QQ-A-250/5	T3	0.020
	Post, outer RH	Al Aly	QQ-A-250/5	T4	0.012
	Post, center RH	Al Honeycomb	MI L-C-7438	—	0.250
	Post, inner RH	Al Aly	QQ-A-250/5	T3	0.008
	Post, outer LH	Al Aly	QQ-A-250/5	T3	0.020
	Post, cntr LH	Al Honeycomb	MI L-C-7438	—	0.375
	Post, inner LH	Fiberglass	Type "E"	—	—
	Post, pan LH	Al Aly	QQ-A-250/5	T4	0.025
	Post, outer RH	Al Aly	QQ-A-250/5	T3	0.020
	Post, cntr RH	Al Honeycomb	MI L-C-7438	—	0.375
	Post, inner RH	Fiberglass	Type "E"	—	—
	Post, pan RH	Al Aly	QQ-A-250/5	T4	0.025
9	Roof, center fwd	Al Aly	QQ-A-250/5	T42	0.020
10	Roof, side LH	Al Aly	QQ-A-250/6	T42	0.020
	Roof, side RH	Al Aly	QQ-A-250/5	T42	0.020
11	Roof, cntr outer	Al Aly	QQ-A-250/5	T3	0.012
	Roof, cntr cntr	Al Honeycomb	MI L-C-7438	—	0.750
	Roof, cntr inner	Al Aly	QQ-A-250/5	T3	0.008
12	Roof, side aft LH	Al Aly	QQ-A-250/5	T4	0.020
	Roof, side aft RH	Al Aly	QQ-A-250/5	T4	0.020
13	Roof, cntr outer LH	Al Aly	QQ-A-250/5	T3	0.012
	Roof, cntr cntr LH	Al Honeycomb	MI L-C-7438	—	0.500
	Roof, cntr inner LH	Al Aly	QQ-A-250/5	T3	0.008
	Roof, cntr outer RH	Al Aly	QQ-A-250/5	T3	0.012
	Roof, cntr cntr RH	Al Honeycomb	MI L-C-7438	—	0.500
	Roof, cntr inner RH	Al Aly	QQ-A-250/5	T3	0.012
14	Hinged, panel	Al Aly	QQ-A-250/5	T4	0.020
	Outer skin				
	Pan	Al Aly	QQ-A-250/5	T4	0.025
16	Door, outbd LH	Al Aly	QQ-A-250/5	T42	0.020
	Door, outbd RH	Al Aly	QQ-A-250/5	T42	0.020
	Door, outbd LH	Al Aly	QQ-A-250/5	T42	0.020
	Door, outbd RH	Al Aly	QQ-A-250/5	T42	0.020
	Door, inbd LH	Al Aly	QQ-A-250/5	T3	0.012
	Door, inbd RH	Al Aly	QQ-A-250/5	T3	0.012
	Door, inbd LH	Al Aly	QQ-A-250/5	T3	0.020
	Door, inbd RH	Al Aly	QQ-A-250/5	T3	0.020
	Door, inbd LH	Al Aly	QQ-A-250/5	T3	0.020
	Door, inbd RH	Al Aly	QQ-A-250/5	T3	0.020
	Door, inbd LH	Al Aly	QQ-A-250/5	T42	0.020
	Door, inbd RH	Al Aly	QQ-A-250/5	T42	0.020
	Door, inbd LH	Al Aly	QQ-A-250/5	T42	0.020
	Door, inbd RH	Al Aly	QQ-A-250/5	T42	0.020
16	Fuselage LH	Al Aly	QQ-A-250/5	T4	0.025
	Fuselage LH	Al Aly	QQ-A-250/5	T6	0.025
	Fuselage LH	Al Aly	QQ-A-250/5	T6	0.025
	Fuselage LH	Al Aly	QQ-A-250/5	T6	0.032

Figure 4-2. Forward Fuselage Skin (Sheet 2 of 6)

Item	Name	Material	Specification	Condition	Thickness
	Fuselage LH	Al Alloy	QQ-A-250/5	T6	0.032
	Fuselage LH	Al Alloy	QQ-A-250/5	T6	0.032
	Fuselage LH	Al Alloy	QQ-A-250/5	T4	0.025
	Fuselage LH	Al Alloy	QQ-A-250/5	T6	0.025
	Fuselage RH	Al Alloy	QQ-A-250/5	T4	0.025
	Fuselage RH	Al Alloy	QQ-A-250/5	T6	0.025
	Fuselage RH	Al Alloy	QQ-A-250/5	T6	0.025
	Fuselage RH	Al Alloy	QQ-A-250/5	T6	0.032
	Fuselage RH	Al Alloy	QQ-A-250/5	T6	0.032
	Fuselage RH	Al Alloy	QQ-A-250/5	T6	0.032
	Fuselage RH	Al Alloy	QQ-A-250/5	T4	0.025
	Fuselage RH	Al Alloy	QQ-A-250/5	T6	0.025
	Fuselage RH	Al Alloy	QQ-A-250/5	T6	0.032
	Fuselage RH	Al Alloy	QQ-A-250/5	T6	0.032
	Fuselage cntr	Al Alloy	QQ-A-250/5	T3	0.032
	Fuselage. cntr	Al Alloy	QQ-A-250/5	T3	0.032
	Fuselage. cntr	Al Alloy	QQ-A-250/5	T3	0.032
	Fuselage. cntr	Al Alloy	QQ-A-250/5	T4	0.025
	Fuselage. cntr	Al Alloy	QQ-A-250/5	T4	0.025
17	Door, outer LH	Fiberglass	Type "E"	-	-
	Door, cntr LH	Al Honeycomb	MI L-C-7438	-	0.500
	Door, cntr LH	Al Honeycomb	MI L-C-7438	-	0.250
	Door, inner LH	Fiberglass	Type "E"	-	-
	Door, outer RH	Fiberglass	Type "E"	-	-
	Door, cntr RH	Al Honeycomb	MI L-C-7438	-	0.500
	Door, cntr RH	Al Honeycomb	MI L-C-7438	-	0.250
18	Door, inner RH	Fiberglass	Type "E"	-	-
	Door, outer LH	Fiberglass	Type "E"	-	-
	Door, cntr LH	Al Honeycomb	MI L-C-7438	-	0.500
	Door, cntr LH	Al Honeycomb	MI L-C-7438	-	0.250
	Door, inner LH	Fiberglass	Type "E"	-	-
	Door, outer RH	Fiberglass	Type "E"	-	-
	Door, center RH	Al Honeycomb	MI L-C-7438	-	0.500
	Door, center RH	Al Honeycomb	MI L-C-7438	-	0.250
	Door, inner RH	Fiberglass	Type "E"	-	-
19	Door, outer LH	Fiberglass	Type "E"	-	-
	Door, center LH	Al Honeycomb	MI L-C-7438	-	0.500
	Door, inner LH	Fiberglass	Type "E"	-	-
	Door, outer RH	Fiberglass	Type "E"	-	-
	Door, center RH	Al Honeycomb	MI L-C-7438	-	0.500
	Door, inner RH	Fiberglass	Type "E"	-	-
20	Service deck outer skin	Titanium	MI L-T-9046	-	0.016
	Service deck core	Al Honeycomb	MI L-C-7438	-	-
	Service deck inner skin	Fiberglass	BHT299-947-059 Type II	-	-

Figure 4-2. Forward Fuselage Skin (Sheet 3 of 6)

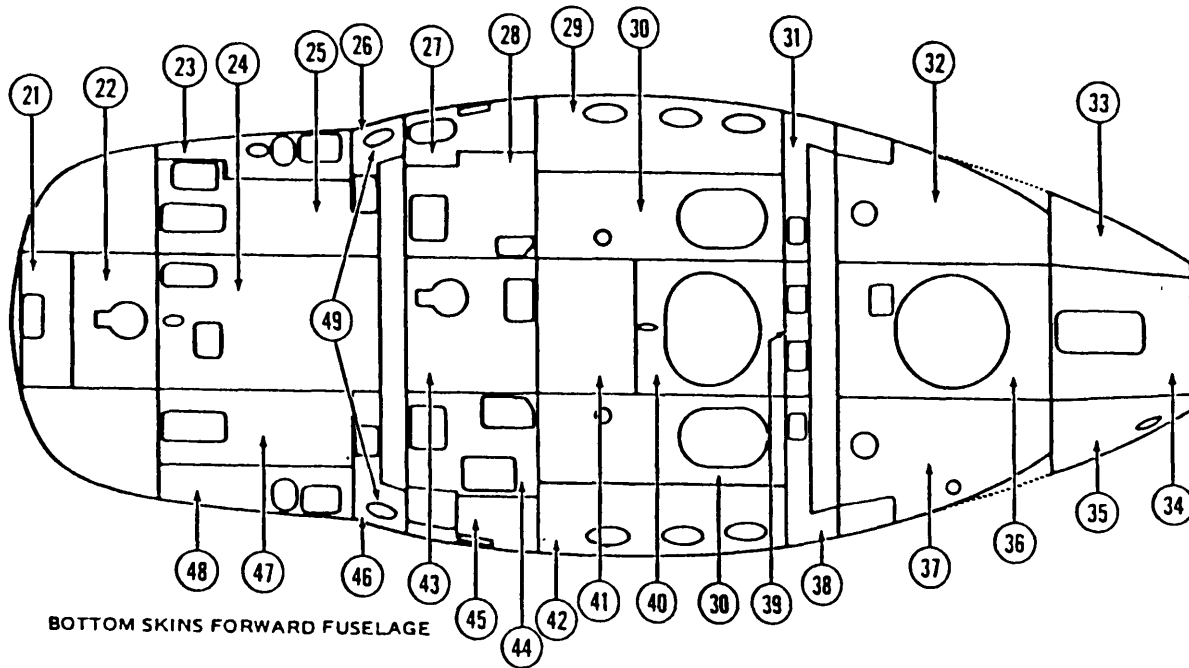

Item	Name	Material	Specification	Condition	Thickness	
21	Door	Al Al y Honeycomb	MIL-C-7438			
22	Skin	Al Al y	QQ-A-250/5	T6	0.020	
23	Skin	Al Al y	QQ-A-250/13	T6	0.025	
24	Skin	Al Al y	QQ-A-250/5	T3	0.032	
25	Skin	Al Al y	QQ-A-250/13	T6	0.032	
26	Skin	Al Al y	QQ-A-250/5	T42	0.025	
27	Skin	Al Al y	QQ-A-250/5	T42	0.025	
28	Skin	Al Al y	QQ-A-250/13	T6	0.032	
29	Skin	Al Al y	QQ-A-250/13		0.032	
30	Panel	Al Al y Honeycomb	MIL-C-7438			
31	Skin	Outer Skin	Al Al y	QQ-A-250/13	T6	0.012
		Inner Skin	BHT299-947-057 Type C	Glass Fabric		
32	Skin	Al Al y	QQ-A-250/13	T6	0.032	
33	Skin	Al Al y	QQ-A-250/13	T6	0.025	
34	Skin	Al Al y	QQ-A-250/5	T42	0.025	
35	Skin	Al Al y	QQ-A-250/13	T6	0.025	
36	Skin	Al Al y	QQ-A-250/5	T42	0.025	
37	Skin	Al Al y	QQ-A-250/13	T6	0.025	
38	Skin	Al Al y	QQ-A-250/13	T6	0.032	
39	Skin	Al Al y	QQ-A-250/5	T3	0.032	
40	Panel	Al Al y Honeycomb	BHT299-947-059 Type I			
41	Panel	Inner Skin	Al Al y	QQ-A-250/13	T6	—
		Outer Skin	Al Al y	QQ-A-250/13	T6	—
42	Skin	Fiber glass/Honeycomb Core				
43	Skin	Al Al y	QQ-A-250/13	T6	0.032	
44	Skin	Al Al y	QQ-A-250/5	T3	0.032	
45	Skin	Al Al y	QQ-A-250/13	T6	0.032	
46	Skin	Al Al y	QQ-A-250/5	T42	0.025	
47	Skin	Al Al y	QQ-A-250/5	T42	0.025	
48	Skin	Al Al y	QQ-A-250/13	T6	0.032	
49	Fairing	Al Al y	QQ-A-250/13	T6	0.025	

Figure 4-2. Forward Fuselage Skin (Sheet 4 of 6)

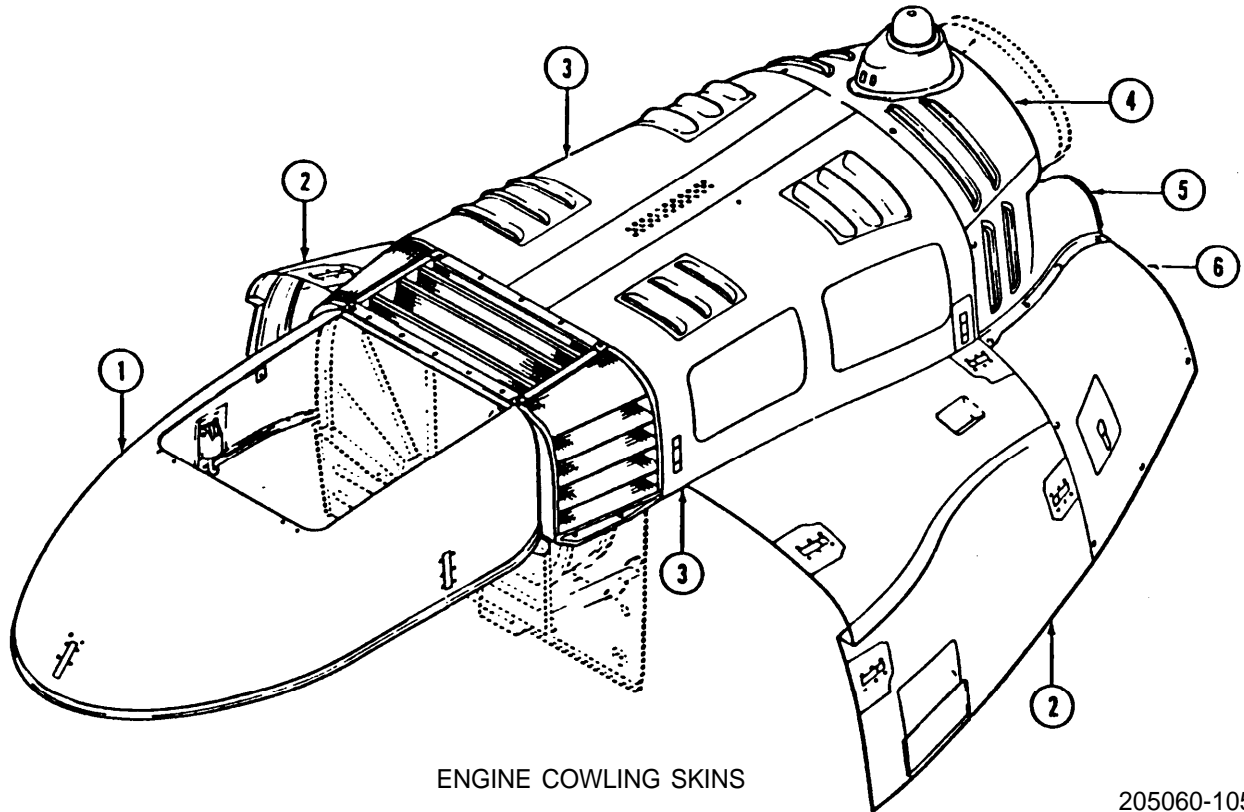

ENGINE COWLING SKINS

205060-1050

Item	Name	Material	Specification	Condition	Thickness
1	Fairing Outer Skin	Glass Fabric	BHT299-947-037. Type E		0.500
	Core Inner Skin	Al Aly Honeycomb Al Aly	BHT299-947-037. Type E		
2	Lower Cowl Inner Skin	Al Aly	QQ-A-362	T4	0.025
	Outer Skin	Al Aly	QQ-A-362	T4	0.020
3	Upper Cowl: Louvers	Al Aly	BHT299-947-012. Type VIII		
	Bulkheads	Al Aly	QQ-A-250/5	T42	0.025
	Skins: Upper Inner	Al Aly	QQ-A-250/5	T42	0.025
	Lower Inner	Al Aly	QQ-A-250/5	T42	0.025
	Outer	Al Aly	QQ-A-250/5	T42	0.020
	Perforated Inner	Al Aly	QQ-A-250/8	H34	0.032
	Tailpipe Fairing				
4	Upper Fairing	Al Aly	QQ-A-250/5	T42	0.025
5	Upper Fairing	Al Aly	QQ-A-250/8		0.025
6	Lower Fairing	Al Aly	QQ-A-250/5	T4	0.020

Figure 4-2. Forward Fuselage Skin (Sheet 5 of 6)

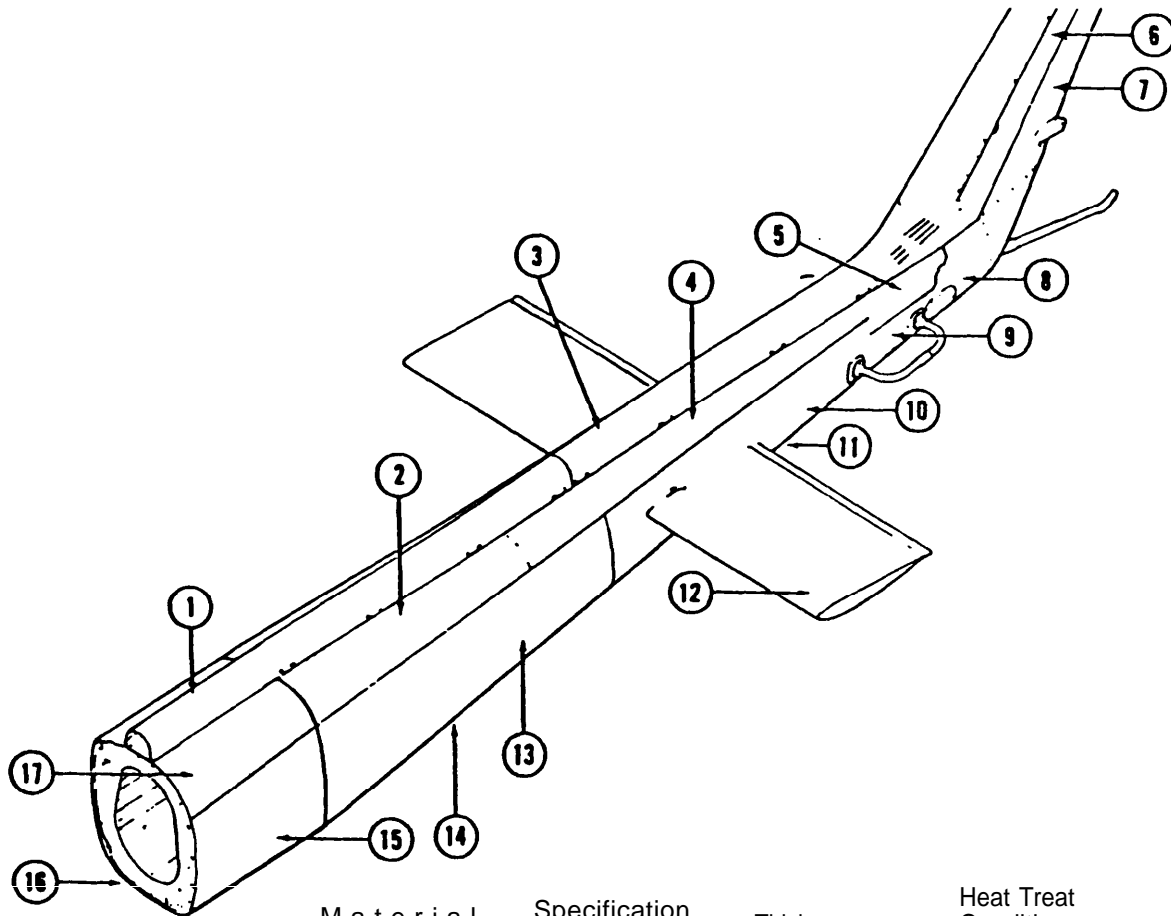

Item	Description	Material	Specification	Thickness	Heat Treat Condition
1	Door Fwd	Al Aly	QQ-A-250/5	0.040	T3
2	Top Forward	Al Aly	QQ-A-250/5	0.020	T3
3	Door Aft	Al Aly	QQ-A-250/5	0.040	T3
4	Top Center	Mag Aly	QQ-M-44	0.032	H24
5	Top Aft	Al Aly	QQ-A-250/5	0.050	T3
6	Fin Fwd LH & RH	Al Aly	QQ-A-250/5	0.025	T3
7	Fin Aft LH & RH	Al Aly	QQ-A-250/5	0.025	T3
8	Fin Lower	Al Aly	QQ-A-250/5	0.032	T3
9	Side Aft	Al Aly	QQ-A-250/5	0.040	T3
10	Side Center Aft	Mag Aly	QQ-M-44	0.032	H24
11	Bottom Aft	Mag Aly	QQ-M-44	0.032	H24
12	Elevator LH & RH	Mag Aly	QQ-M-44	0.025	H24
13	Side Fwd LH	Mag Aly	QQ-M-44	0.025	H24
	Side Fwd RH	Mag Aly	QQ-M-44	0.040	H24
14	Bottom Forward	Mag Aly	QQ-M-44	0.025	H24
15	Fwd Sec Side LH	Mag Aly	QQ-M-44	0.025	H24
	Fwd Sec Side RH	Mag Aly	QQ-M-44	0.040	H24
16	Fwd Sec Bottom	Mag Aly	QQ-M-44	0.025	H24
17	Fwd Sec Top	Al Aly	QQ-A-250/5	0.020	T3

Figure 4-2. Forward Fuselage Skin (Sheet 6 of 6)

4-2. ASSESSMENT PROCEDURES.

a. Use fault isolation flow diagram, paragraph 4-2.c, and Tables 4-1 thru 4-10 to determine allowable damage limits for specific areas of the helicopter's structure. Tables 4-1 thru 4-5 list the damage which is deferrable. Damage limits in Tables 4-6 thru 4-10 are repairable by BDAR or standard repairs if time and material are available. Damage exceeding limits of Tables 4-6 thru 4-10 is cause for grounding the helicopter.

b. For assessment purpose, the helicopter is broken down into five general sections as shown in Figure 4-1, sheet 3. These sections are nose, cabin roof, fwd fuselage, midsection fuselage, aft fuselage, and tail boom section. Further, some areas of critical structural importance are also listed in special sections. To repair damage to the helicopter, find the area of damage by the use of damage assessment flow chart, paragraph 4-2.c, and by use of the index in paragraph 4-3.

c. Visually Inspect Damage.

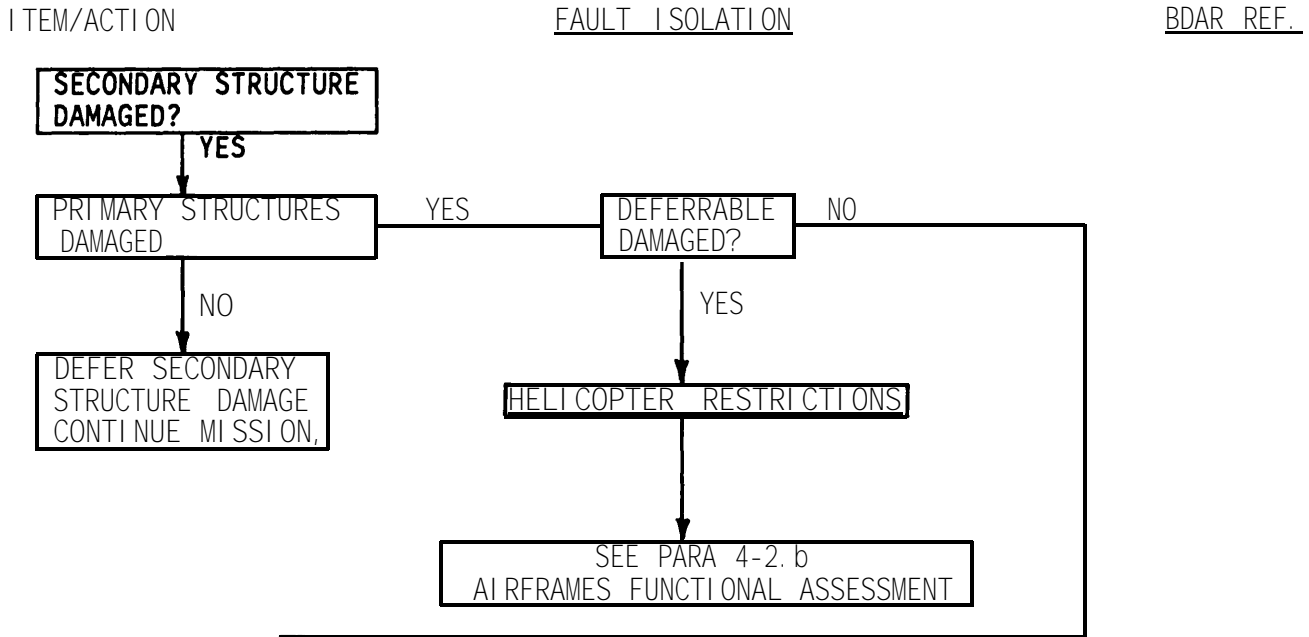

d. Detail Assessment Inspection.

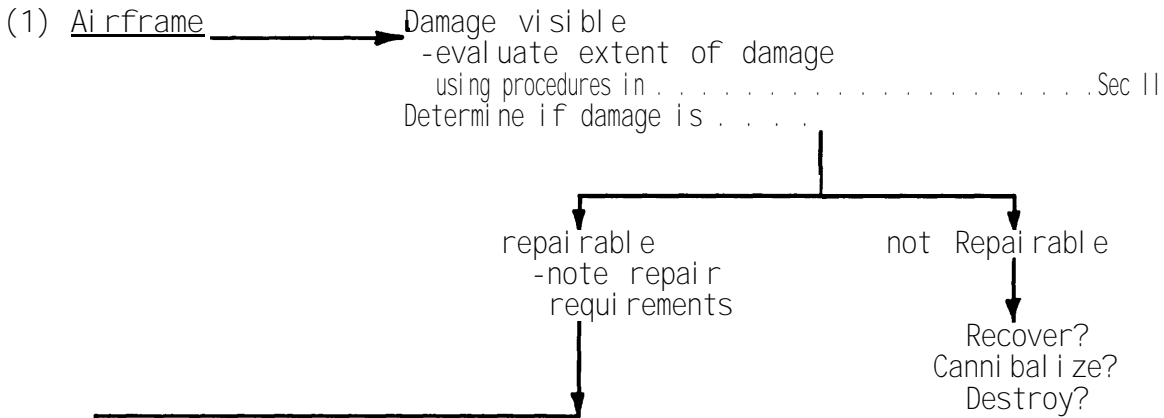

(2) To continue assessment, Insert one of the following sections listed below in paragraph 4-3 in diagram above, replacing the shown airframe. Continue this assessment until all areas are covered.

4-3. REPAIR PROCEDURE INDEX.

	PARA.
Cabin Roof	Sec II, Tables 4-1, 4-6
Forward Fuselage Section	Sec II, Tables 4-2, 4-7
Fuselage Midsection	Sec II, Tables 4-3, 4-8
Fuselage Aft Section	Sec II, Tables 4-4, 4-9
Tail Boom and Fin Section	Sec II, Tables 4-5, 4-10
Nose Section.	Sec III

Section II. AIRFRAMES

4-4. GENERAL.

a. There is no easy way to identify all possible types of airframe structure damage that can occur. The location and the severity of airframe structure damage can vary a great deal. Tables 4-1 thru 4-10 and Figure 4-3 will assist with identifying damage and determining what is to be acceptable or to be repaired.

b. Except with the limits of damage allowed, Tables 4-1 thru 4-10 are identical.

(1) Tables 4-1 thru 4-5 list condition I limits. Damage less than these limits are acceptable without any rework, and repairs are deferrable.

(2) Tables 4-6 thru 4-10 list condition II limits. They identify damage limits exceeding condition I. Condition II helicopters will have flight restrictions imposed and will only be flown for self-recovery capable mission. Helicopters with condition II can be upgraded to condition I by repairing all damage exceeding condition I.

(3) Helicopters with battle damage which exceed Tables 4-6 thru 4-10 should be grounded.

4-5. GENERAL SKIN AND STRUCTURAL DAMAGE.

LIMITATIONS: Listed in Tables 4-1 thru 4-10 and Figure 4-3.

PERSONNEL/TIME REQUIRED: See individual repairs listed in Chapter 3.

MATERIALS/TOOLS REQUIRED:

- Standard Sheet Metal/Mechanics Tools
(See App B & C)

PROCEDURAL STEPS:

1. Inspect obvious skin damage. Even though skin damage is secondary structure and damage may not appear to be critical, the underlying or adjacent primary structure may have hidden critical damage. Inspect primary structure under the skin damage for:

a. Visual cracks in structure.

b. Metal deformation in both primary and secondary structure.

c. Embedded projectiles or fragmentations.

d. Fire damage for fire weakened metals.

e. Broken or missing fasteners.

2. Measure the damage as instructed in Tables 4-1 thru 4-10 and Figure 4-3.

a. If damage is within limits of Tables 4-1 thru 4-5, then it is deferrable.

b. If damage exceeds the limits of Tables 4-1 thru 4-5 but is less than Tables 4-6 thru 4-10, then this damage can be upgraded to condition I by repairing condition II damage.

c. If damage exceeds Tables 4-6 thru 4-10, then aircraft cannot be flown and will have to be evacuated otherwise.

3. Repair all damage using BDAR fixes in Chapter 3, General Repairs.

4. Record BDAR action taken. When mission is complete, as soon as practical, repair the equipment/system using standard maintenance procedures.

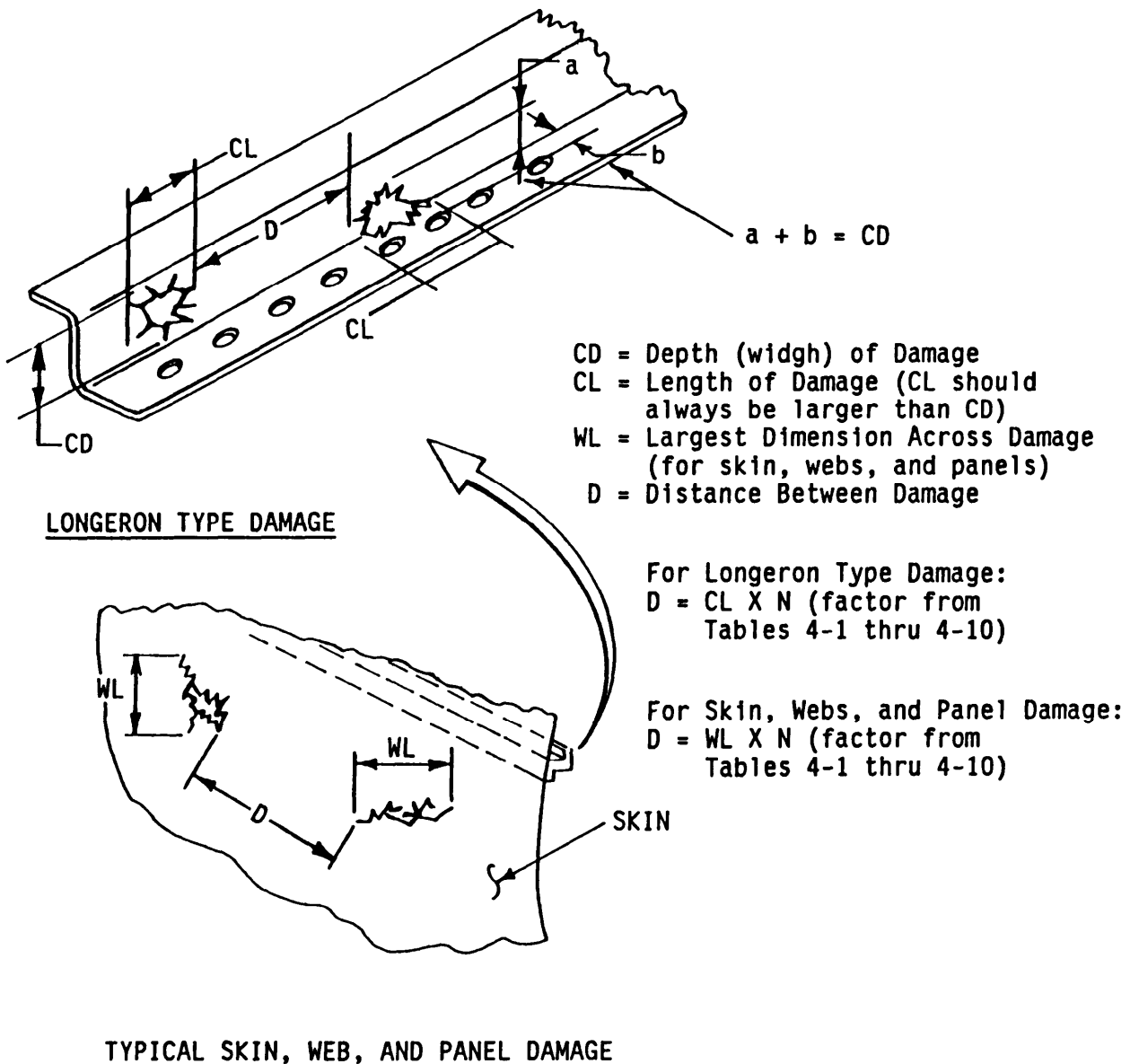

Figure 4-3. Damage Limits Measurement for Tables 4-1 thru 4-10

Table 4-1. Damage Limits Cabin Roof - Condition I

COMPONENT/ MEMBER	LOCATION			ELEMENT	DAMAGE LIMITS					FIGURE 4-1 AND NOTES
	FS	WL	BL		CAP/FLANGE			SKIN/WEB		
					CD'	CL'	N	WL'	N	
DOOR POST	74.25	FROM 22.00 TO 78.00		POST R/H & L/H	(D'=NxCL) .01					SHEET 3 OF 15
	63.38	FROM 22.00 TO -69.00		POST R/H & L/H	.43	.86	10			
	63.38	FROM 69.00 TO -71.00		SPLICE R/H & L/H	NO RIVET DAMAGE					
	63.38	FROM 69.00 TO -71.00		POST R/H & L/H	.43	.86	10			
	63.38 -74.25	FROM 22.00 TO -78.00	34.10 OUTBD	WEB R/H & L/H					2 WEBS SEVERED	
	63.38 -74.25	FROM 22.00 TO -78.00		SKIN	NO LIMIT ON DAMAGE TO ELEMENT					
BULKHEAD	112.8	80.00	15.25L -15.25R	UPPER FLANGE	.1	.2	10			
	112.8	FROM 75.60 TO 80.00	15.25L -15.25R	WEB	1.57	3.14	10			
	81.00 83.00	FROM 75.00 TO 80.00	30.00L&R -OUTBD	FRAME	1.02	2.04	10			
	63.38	FROM 75.60 TO 80.00	31.25L -31.25R	FRAME	.04	.08	10			
	63.38	FROM 75.60 TO 80.00	31.25L&R -OUTBD	FRAME	1.03	2.06	10			

Table 4-1. Damage Limits Cabin Roof - Condition I (Cont)

COMPONENT/ MEMBER	LOCATION			ELEMENT	DAMAGE LIMITS				FIGURE 4-1 AND NOTES	
	FS	WL	BL		CAP/FLANGE			SKIN/WEB		
					CD'	CL'	N	WL'		N
					(D' = NxCL)			(D' = NxWL)		
BULKHEAD	74.25	80.00	16.00L&R	UPPER FLANGE	.05	.10	10			
	74.25	FROM 75.60 TO -80.00	16.00L&R	WEB	.38	.76	10			
	92.00	80.00	16.00L&R	UPPER FLANGE	.08	.16	10			
	92.00	FROM 75.60 TO -80.00	16.00L&R	WEB	.93	1.86	10			
	74.25	FROM 75.60 TO -80.00	30.00L&R OUTBD	CAP	1.02	2.04	10			
	92.00	FROM 75.60 TO -80.00	30.00L&R OUTBD	FRAME	1.02	2.04	10			
	74.25	FROM 75.60 TO -80.00	16.00 -30.00L&R	FRAME	.73	1.46	10			
	92.00	FROM 75.60 TO -80.00	16.00 -30.00L&R	FRAME	.87	1.74	10			
	157.50 -159.50	FROM 75.00 TO -80.00	30.00L&R -OUTBD	FRAME	1.18	2.36	10			
	130.01 -132.01	FROM 75.00 TO -80.00	30.00L&R -OUTBD	FRAME	1.12	2.24	10			

Table 4-1. Damage Limits Cabin Roof - Condition I (Cont)

COMPONENT/ MEMBER	LOCATION			ELEMENT	DAMAGE LIMITS					FIGURE 4-1 AND NOTES
	FS	WL	BL		CAP/FLANGE			SKIN/WEB		
					CD'	CL'	N	WL'	N	
BULKHEAD	104.00	FROM 75.00 TO	30.00L&R	FRAME	1.06	2.12	10			
	-106.00	-80.00	-OUTBD							
	114.71	FROM 75.00 TO	30.00L&R							
		-80.00	-OUTBD							
	142.00	FROM 75.00 TO	30.00L&R							
		-80.00	-OUTBD							
	148.00	FROM 75.00 TO	30.00L&R							
		-80.00	-OUTBD							
LONGERON	63.38	FROM 75.60 TO		FRAME	.02	.04	10			
	-126.97	-80.00	15.25L&R							
	74.25	FROM 75.60 TO	30.00L&R							
		-80.00								
	114.71	FROM 75.60 TO	30.00L&R							
		-80.00								
	131.80	FROM 75.60 TO	30.00L&R							
		-80.00								
	63.38	FROM 75.60 TO	30.00L&R							
		-80.00								
	126.97	FROM 75.60 TO	15.25L&R							
		-80.00								
DOOR POST	157.50	FROM 75.00 TO	37.00-	SUPPORT BRACKET	.02	.04			ONE DAMAGED	
	159.50	80.00	39.00L&R							

Table 4-1. Damage Limits Cabin Roof - Condition I (Cont)

COMPONENT/ MEMBER	LOCATION			ELEMENT	DAMAGE LIMITS					FIGURE 4-1 AND NOTES
	FS	WL	BL		CAP/FLANGE			SKIN/WEB		
					CD'	CL'	N	WL'	N	
DOOR POST	81.00 -83.00	FROM 75.00 TO -80.00	34.10- 36.10L&R	SUPPORT BRACKET	(D'=NxCL)			(D'=NxWL)		ONE DAMAGED
	130.01 -132.01	FROM 75.00 TO -80.00	38.50- 40.50L&R	SUPPORT BRACKET	.02	.04				
	104.00 -106.00	FROM 75.00 TO -80.00	34.10- 36.10L&R	SUPPORT BRACKET	.11	.22				
DOORS	63.38 -166.00	72.60		CARGO DOOR RAIL	NO LIMIT ON DAMAGE TO ELEMENT					
	166.00			CARGO DOOR						
	74.25	FROM 22.00 TO -78.00		HINGED PANEL DOOR						
ROOF PANEL/ RIVETS	63.38 -126.97	80.00	12.25- 16.00L&R	PANEL EDGE	.42	.84	5			
	80.00 -84.00	80.00	9.00- 13.00L&R	STN RIVETS						FOUR RIVETS DAMAGE
	63.38	80.00	16.00L&R	CP RIVETS						TEN RIVETS DAMAGE
	63.38 -66.38	80.00	12.25L&R	PANEL EDGE	.12	.24	5			
	80.00 -84.00	80.00	12.25L&R	CENTER PANEL	1.76	3.52	5			

Table 4-1. Damage Limits Cabin Roof - Condition I (Cont)

COMPONENT/ MEMBER	LOCATION			ELEMENT	DAMAGE LIMITS				FIGURE 4-1 AND NOTES		
	FS	WL	BL		CAP/FLANGE			SKIN/WEB			
					CD'	CL'	N	WL'		N	
ROOF PANEL RIVETS	98.00 -102.00	80.00	12.25L&R	CENTER PANEL	(D' = NxCL)			(D' = NxWL)			
	66.38 -80.00	80.00	12.25L&R	CENTER PANEL	2.79	5.58	5				
	84.00 -98.00	80.00	12.25L&R	CENTER PANEL				3.1	5		
	102.00 -126.97	80.00	12.25L&R	CENTER PANEL				3.1	5		
	63.38 -166.00	80.00	30.00L&R -OUTBD	ROOF PANEL	NO LIMIT ON DAMAGE TO ELEMENT						
	63.38 -166.00	80.00	16.00- 30.00L&R	ROOF PANEL				6.00	5		

Table 4-2. Damage Limits Fuselage, Forward (FS 23 to 129) - Condition I

COMPONENT/ MEMBER	LOCATION			ELEMENT	DAMAGE LIMITS				FIGURE 4-1 AND NOTES	
	FS	WL	BL		CAP/FLANGE			SKIN/WEB		
					CD'	CL'	N	WL'		N
FORWARD SECTION BOTTOM	102.00 -129.00	BOTTOM -22.00	34.70L&R -OUTBD	SKIN	(D'=NxCL)			(D'=NxWL) 2.50 5		CRITICAL WITH EXTERNAL STORES
	23.00 -102.00	BOTTOM -22.00	c - L&R OUTBD	SKIN						SKIN NOT CRITICAL
	102.00 -129.00	BOTTOM	34.70L&R	SKIN						
DECKS	63.33 -129.00	22.00	c - L&R OUTBD	CARGO TIEDOWN FITTINGS	DO NOT USE FITTINGS WITH DAMAGE WITHIN 6 INCHES OF FITTINGS					
	74.25 -123.00	22.00	14.00L&R	DOOR ASSEMBLY HONEYCOMB PANEL				8.00 5		NO DAMAGE WITHIN 1.5 INCH OF EDGE
	74.25 -123.00	22.00	14.00L&R	EDGE HONEYCOMB PANEL	1.00 1.25 10					
	23.00 -74.22	22.00	c - L&R OUTBD	HONEYCOMB PANELS				8.00 5		NO DAMAGE WITHIN 1.5 INCH OF EDGE
	23.00 -74.00	22.00	c - L&R OUTBD	EDGE HONEYCOMB PANELS	1.00 1.25 10					
	74.00 -129.00	22.00	14.00L&R -OUTBD	HONEYCOMB PANELS				8.00 5		NO DAMAGE WITHIN 1.5 INCH OF EDGE
	123.06 -128.75	22.00	14.00L&R	ENDS HONEYCOMB PANEL	1.00 1.50 10					
	123.06 -128.75	22.00	14.00L&R	HONEYCOMB PANEL				2.00 5		NO DAMAGE WITHIN 1.5 INCH OF EDGE

Table 4-2. Damage Limits Fuselage, Forward (FS 23 to 129) - Condition I (Cont)

COMPONENT / MEMBER	LOCATION			ELEMENT	DAMAGE LIMITS				FIGURE 4-1 AND NOTES	
	FS	WL	BL		CAP/FLANGE			SKIN/WEB		
					CD'	CL'	N	WL'		N
MAIN BEAM				UPPER CAP SPLICE INSIDE & OUTSIDE	(D' = NxCL)			(D' = NxWL)		
	112.50	22.00	14.00L&R		0.70	1.40	10			
	23.00 -41.70	22.00	14.00L&R	UPPER CAP	0.65	1.30	10			
	41.70 -69.00	22.00	14.00L&R	UPPER CAP	0.75	1.50	10			
	69.00 -83.80	22.00	14.00L&R	UPPER CAP	0.75	1.50	10			
	83.80 -95.50	22.00	14.00L&R	UPPER CAP	0.90	1.80	10			
	95.50 -129.00	22.00	14.00L&R	UPPER CAP	0.25	0.50	10			
	23.00 -34.00	BOTTOM CONTOUR	14.00L&R	LOWER CAP	0.00	0.00	10			
	34.00 -60.00	LOWER CONTOUR	14.00L&R	LOWER CAP	0.00	0.00	10			
	60.00 -69.80	LOWER CONTOUR	14.00L&R	LOWER CAP	0.35	0.70	10			
	73.50 -78.07	LOWER CONTOUR	14.00L&R	LOWER CAP	0.15	0.30	10			
	78.07 -117.00	LOWER CONTOUR	14.00L&R	LOWER CAP	0.55	1.10	10			
	117.00 -129.00	LOWER CONTOUR	14.00L&R	LOWER CAP	0.00	0.00	10			

Table 4-2. Damage Limits Fuselage, Forward (FS 23 to 129) - Condition I (Cont)

COMPONENT/ MEMBER	LOCATION			ELEMENT	DAMAGE LIMITS					FIGURE 4-1 AND NOTES
	FS	WL	BL		CAP/FLANGE			SKIN/WEB		
					CD'	CL'	N	WL'	N	
MAIN BEAM	69.00	LOWER CONTOUR	14.00L&R	CROSS TUBE FITTING	NO DAMAGE ALLOWED					
	-74.30									
	47.60	FROM 12.00 TO -22.00	14.00L&R	STIFFENER	0.50	1.00	10			
	63.33	FROM 9.90 TO -22.00	14.00L&R	STIFFENER	2.30	4.60	10			
	69.00	FROM 9.90 TO -22.00	14.00L&R	STIFFENER	2.05	4.10	10			
	74.00	FROM 9.90 TO -22.00	14.00L&R	STIFFENER	2.10	4.20	10			
	90.50	FROM 9.90 TO -22.00	14.00L&R	STIFFENER	0.55	1.10	10			
	102.00 -129.00	FROM 9.90 TO -22.00	14.00L&R	HONEYCOMB				7.50	5	
	23.00 -37.00	FROM 10.90 TO -22.00	14.00L&R	WEB				8.75	5	INCLUDES ACCESS HOLES
	37.00 -47.60	FROM 10.00 TO -22.00	14.00L	WEB				5.50	5	
	37.00 -47.60	FROM 10.00 TO -22.00	14.00R	WEB				2.45	5	
	47.00 -69.00	FROM 9.00 TO -22.00	14.00L	WEB				4.25	5	

Table 4-2. Damage Limits Fuselage, Forward (FS 23 to 129) - Condition I (Cont)

COMPONENT/ MEMBER	LOCATION			ELEMENT	DAMAGE LIMITS				FIGURE 4-1 AND NOTES	
	FS	WL	BL		CAP/FLANGE			SKIN/WEB		
					CD'	CL'	N	WL'		N
MAIN BEAM	47.00 -69.00	FROM 9.00 TO -22.00	14.00R	WEB	(D'=NxCL)			(D'=NxWL)	INCLUDES ACCESS HOLES	
	69.00 -74.30	FROM 8.00 TO -22.00	14.00L&R	WEB						
	74.30 -78.10	FROM 7.44 TO -22.00	14.00L&R	WEB				7.10 5		
	78.10 -102.00	FROM 7.44 TO -22.00	14.00L&R	WEB				2.75 5		
BULKHEAD	63.33	22.00	c - L&R OUTBD	UPPER CAP	0.50	1.00	10			
	63.33	LOWER CONTOUR	c - L&R OUTBD	LOWER CAP	0.15	0.30	10			
	63.33	LOWER CONTOUR	30.00L&R	LOWER CAP JACKING POINT	JACK ONLY IF CAP WILL SUPPORT HELICOPTER					
	63.33	LOWER CONTOUR	14.00L&R	SPLICE PLATE	0.50	1.00	10			
	63.33	FROM 7.44 TO -22.00	c - L&R OUTBD	WEB				4.00 5	INCLUDES ACCESS HOLES	
	74.30	LOWER CONTOUR	c - L&R OUTBD	LOWER CAP	0.40	0.80	10			
	74.30	LOWER CONTOUR	14.00L&R	SPLICE	2.45	4.90	10			

Table 4-2. Damage Limits Fuselage, Forward (FS 23 to 129) - Condition I (Cont)

COMPONENT/ MEMBER	LOCATION			ELEMENT	DAMAGE LIMITS				FIGURE 4-1 AND NOTES	
	FS	WL	BL		CAP/FLANGE			SKIN/WEB		
					CD'	CL'	N	WL'		N
BULKHEAD	74.30	FROM 7.44 TO -22.00	c - L&R OUTBD	WEB	(D'=NxCL)			(D'=NxWL)		INCLUDES ACCESS HOLES
	74.30	22.00	c - L&R OUTBD	UPPER CAP	0.50	1.00	10			
	23.00 37.00	BOTTOM CONTOUR & 22.00	c - L&R OUTBD	UPPER AND LOWER CAPS	*	2XCD	10			*25% OF CROSS- SECTIONAL AREA
	52.00 69.00									
	84.50 102.00									
	23.00 37.00	BOTTOM CONTOUR -22.00	c - L&R OUTBD	WEBS				*		*50% OF ANY SECTION
	52.00 69.00									
	84.50 102.00									
SEAT RAILS	41.00 -51.00	22.00	14.00L&R 30.00L&R	SEAT TRACK (FWD)	0.75	1.50	10			
	55.70 -63.33	22.00	14.00L&R 30.00L&R	SEAT TRACK (AFT)	0.25	0.50	10			
SEAT SUPPORT BEAM	37.00 -63.33		30.00L&R	SEAT TRACK SUPPORT (CAP)	0.75	1.50	10			

Table 4-2. Damage Limits Fuselage, Forward (FS 23 to 129) - Condition I (Cont)

COMPONENT/ MEMBER	LOCATION			ELEMENT	DAMAGE LIMITS			FIGURE 4-1 AND NOTES		
	FS	WL	BL		CAP/FLANGE				SKIN/WEB	
					CD'	CL'	N		WL'	N
SEAT SUPPORT BEAM	37.00 -63.00	LOWER CONTOUR	30.00L&R	LOWER CAP	(D'=NxCL)			(D'=NxWL)		
	37.00 63.33	LOWER CONTOUR	30.00L&R	VERTICAL STIFFE- NERS (CHANNELS)	0.65	1.30	10			
SEAT RAILS	63.33	LOWER CONTOUR	30.00L&R	JACK FITTING & BACKUP STRUCTURE	DO NOT JACK IF DAMAGED AREA WILL NOT SUPPORT HELICOPTER					
PEDAL SUPPORT	23.00 -29.08	14.75	19.16L&R	STIFFENERS	0.06	0.12	10			
	34.75 -37.00	12.00 -22.00	19.16L&R	PEDAL ADJUSTER SUPPORT	0.45	0.90	10			
	23.00 -37.00	22.00	19.16L&R	CAP	0.45	0.90	10			
JACKING & MOORING FITTINGS	62.78	LOWER CONTOUR	30.00L&R	FITTING	DO NOT USE IF FURTHER DAMAGE WILL OCCUR					
LANDING GEAR	71.60	9.90	14.00L&R	FITTING	0.00	0.00	10			

Table 4-3. Damage Limits Fuselage, Midsection (FS 129 to 178) - Condition I

COMPONENT/ MEMBER	LOCATION			ELEMENT	DAMAGE LIMITS				FIGURE 4-1 AND NOTES	
	FS	WL	BL		CAP/FLANGE			SKIN/WEB		
					CD'	CL'	N	WL'		N
					(D' = NxCL)			(D' = NxWL)		
MIDSECTION, BOTTOM	129.00 -155.00	LOWER CONTOUR	34.7-OUTBD L&R	SKIN				2.50	5	WITH EXTERNAL STORES
	155.00 -178.0	LOWER CONTOUR	c-OUTBD L&R	SKIN				5.00	5	
	102.00	LOWER CONTOUR	14.00- 34.7L&R	HONEYCOMB PANEL				8.00	5	NO DAMAGE WITHIN 1.5 INCH OF EDGE
	129.00 -155.06	LOWER CONTOUR	14.00L -14.00R	HONEYCOMB PANEL				8.00	5	
HOIST MAINTENANCE SUPPORT	157.70	22.00	26.00L	UPPER SKIN	IF FLOOR SUPPORT IS DAMAGED, USE CARE WHEN USING HOIST					
	157.70	22.00	26.00L	DOUBLER						
MIDSECTION FLOOR	166.00 -178.00	22.00 -25.58	14.00- OUTBD L&R	HONEYCOMB PANEL				6.50	5	NO DAMAGE WITHIN 1.5 INCH OF EDGE
	155.00 -178.00	22.00	14.00L -14.00R	HONEYCOMB PANEL				3.90	5	
	129.00 -166.00	22.00	14.00- OUTBD L&R	HONEYCOMB PANEL				8.00	5	
	129.00 -178.00	22.00		HONEYCOMB PANEL EDGES	1.00	5.00	10			
MIDSECTION	166.00	22.00 -54.89	14.00L&R	FRAME CHANNEL AND ANGLE	0.20	0.40	10			

Table 4-3. Damage Limits Fuselage, Midsection (FS 129 to 178) - Condition I (Cont)

COMPONENT/ MEMBER	LOCATION			ELEMENT	DAMAGE LIMITS					FIGURE 4-1 AND NOTES
	FS	WL	BL		CAP/FLANGE			SKIN/WEB		
					CD'	CL'	N	WL'	N	
MIDSECTION	155,160 166,178	FROM	14.00L&R	VERTICAL ANGLES	(D'=NxCL)			(D'=NxWL)		EACH ANGLE
		22.00 TO -54.89			0.50	1.00	10			
BULKHEAD	152.75 -166.00	FROM	14.00L&R	AFT, LOWER DOOR HONEYCOMB				8.50	5	
		54.68 TO -68.64								
	158.00	61.00	14.00L&R	LITTER SUPPORT PLATE	DO NOT USE IF DAMAGE IS EXCESSIVE					
	129.00 -136.90	FROM 39.60 TO -54.90	14.00L&R	HONEYCOMB PANEL				1.00	5	NO DAMAGE WITHIN 1.0 INCH OF EDGE
	129.00	FROM 22.00 TO -39.60	14.00L -14.00R	DOOR SKIN				7.70	5	
	129.00	FROM 39.60 TO -54.00	14.00L -14.00R	SKIN BEYOND DOOR DOUBLER	0.35	0.70	10			
	129.00	FROM 41.60 TO -50.60	c-10.00L	DOOR DOUBLER AND SKIN	0.75	1.50	10			
	129.00	FROM 54.02 TO -65.86	14.00L -14.00R	WEB, CANTED				5.00	5	
	155.00	FROM 22.00 TO -54.89	14.00L -14.00R	CENTER PANEL				12.00	5	
	155.00	22.00	14.00L&R	TENSION FITTINGS	NO DAMAGE ALLOWED					
	166.00	22.00- LOWER CONTOUR	30.00- OUTBD L&R	WEB, OUTER				0	5	DOES NOT INCLUDE LIGHTENING HOLES

Table 4-3. Damage Limits Fuselage, Midsection (FS 129 to 178) - Condition I (Cont)

COMPONENT/ MEMBER	LOCATION			ELEMENT	DAMAGE LIMITS					FIGURE 4-1 AND NOTES
	FS	WL	BL		CAP/FLANGE			SKIN/WEB		
					CD'	CL'	N	WL'	N	
BULKHEAD	166.00	22.00	14.00L&R	TENSION STRAP, VERTICAL	0.20	0.40	10			
	166.00	22.00	14.00L&R	TENSION STRAP ACROSS BULKHEAD, UPPER	0.02	0.04	10			
	166.00	LOWER CONTOUR	14.00L&R	COMPRESSION STRAP ACROSS BULKHEAD, LOWER	0.12	0.24	10			
	129.00 -155.00	FROM 22.00 TO -39.60	14.00L&R	HONEYCOMB PANEL				7.50	5	NO DAMAGE WITHIN 1.5 INCH OF EDGE
	155.00 -178.00	FROM 22.00 TO -54.00	14.00L&R	HONEYCOMB PANEL				6.00	5	
	166.00	FROM 22.00 TO -54.00	14.00- OUTBD L&R	HONEYCOMB PANEL				7.50	5	
	129.00 -178.00	FROM 22.00 TO -65.86	c-OUTBD L&R	EDGE, HONEYCOMB PANEL	1.00	5.00	10			
	136.90 -155.06	FROM 39.60 TO -54.00	14.00L&R	HONEYCOMB PANEL				2.50	5	NO DAMAGE WITHIN 1.5 INCH OF EDGE
BEAM, LOWER MIDSECTION	129.00 -136.00	LOWER CONTOUR	14.00L&R	LOWER BEAM CAP	0.25	0.50	10			
	136.00 -172.30	LOWER CONTOUR	14.00L&R	LOWER BEAM CAP	0.90	1.80	10			
	172.30 -178.00	LOWER CONTOUR	14.00L&R	LOWER BEAM CAP	0.25	0.50	10			

Table 4-3. Damage Limits Fuselage, Midsection (FS 129 to 178) - Condition I (Cont)

COMPONENT/ MEMBER	LOCATION			ELEMENT	DAMAGE LIMITS				FIGURE 4-1 AND NOTES	
	FS	WL	BL		CAP/FLANGE			SKIN/WEB		
					CD'	CL'	N	WL'		N
BEAM, LOWER MIDSECTION	166.00	LOWER CONTOUR	14.00L&R	CROSS TUBE STRAP LOWER CAP	(D'=NxCL) 0.25 0.50 10			(D'=NxWL)		
	129.00 -178.00	22.00	14.00L&R	UPPER BEAM CAP	0.35 0.70 10					
	102.00 -155.00	22.00- LOWER CONTOUR	14.00L&R	HONEYCOMB PANEL				7.50 5		NO DAMAGE WITHIN 1.5 INCH OF EDGE
	102.00 -155.00	22.00 LOWER CONTOUR	14.00L&R	EDGE HONEYCOMB PANEL	0.35 0.70 10					
	155.00 -178.00	22.00 LOWER CONTOUR	14.00L&R	WEB				3.00 5		DOES NOT INCLUDE HOLES
BEAM, LOWER	102.00 -155.06	LOWER CONTOUR	36.00L&R	INTERCOASTAL	0.25 0.50 10					
	102.00 -155.06	22.00- LOWER CONTOUR	36.00L&R	HONEYCOMB PANEL				6.90 5		DOES NOT INCLUDE HOLES
	102.00 -155.00	22.00	36.00L&R	UPPER CAP	1.20 2.40 10					
MIDSECTION	136.90 -178.00	54.89	14.00L&R	BEAM CAP	0.60 1.20 10					
BULKHEADS	129.00 134.00	22.00- LOWER CONTOUR	c-OUTBD L&R	UPPER AND LOWER CAPS	* 2XCD 10					*25% OF CROSS- SECTIONAL AREA
	155.00 160.00									

Table 4-3. Damage Limits Fuselage, Midsection (FS 129 to 178) - Condition I (Cont)

COMPONENT / MEMBER	LOCATION			ELEMENT	DAMAGE LIMITS				FIGURE 4-1 AND NOTES	
	FS	WL	BL		CAP/FLANGE			SKIN/WEB		
					CD'	CL'	N	WL'		N
BULKHEADS	129.00	22.00- LOWER CONTOUR	c-OUTBD L&R	WEBS	(D'=NxCL)			(D'=NxWL)		*50% OT ANY SECTION
	134.00								* 5	
	155.00 160.00									
PYLON SUPPORT	129.00 -155.00	54.89 FROM 66.00 TO -67.57	14.00L&R	ZEE	0.50	1.00	10			
	131.82 -149.11		10.25- 14.00L&R	ZEE	0.75	1.50	10		DOES NOT INCLUDE LIGHTENING HOLES	
	127.47 -153.45	FROM 65.92 TO -68.14	14.44L&R	ANGLE	0.05	0.10	10			
	149.25	54.89	10.25 -14.44	TEE EXTRUSION	0.55	1.10	10			
	153.45	FROM 68.19 TO -67.59	9.80 -14.00	WEB (THRU RIVETS)	2.30	4.60	10			
	153.45	FROM 68.19 TO -54.89	14.00R -14.00L	WEB				3.00 5	EACH SIDE	
	153.45	FROM 68.19 TO -54.89	14.00L&R	STIFFENER	0.55	1.10	10			
PYLON MOUNT	129.55 -151.32	FROM 66.25 TO -65.92	12.37L&R	BOX FITTING	NO DAMAGE ALLOWED					
LIFT LINK BEAM	136.13 &138.93	FROM 54.89 TO -40.41	3.78 -8.75	WEB				2.75 5		

Table 4-3. Damage Limits Fuselage, Midsection (FS 129 to 178) - Condition I (Cont)

COMPONENT/ MEMBER	LOCATION			ELEMENT	DAMAGE LIMITS					FIGURE 4-1 AND NOTES
	FS	WL	BL		CAP/FLANGE			SKIN/WEB		
					CD'	CL'	N	WL'	N	
LIFT LINK BEAM	136.13 -138.73		14.00L -14.00R	CAPS, UPPER WITH DOUBLER	(D' = NxCL)			(D' = NxWL)		
		FROM 54.89 TO &138.23 -40.41	14.00L -14.00R	CAPS, UPPER WITHOUT DOUBLER	0.55	1.10	10			
	136.18 &138.73	FROM 54.89 TO -40.41	8.55L&R	STIFFENERS	0.0	0.0	10			
	136.18 &138.73	FROM 54.89 TO -40.41	14.00L -14.00R	WEB AND DOUBLER				0.55	5	
	136.18 &138.73	40.41	14.00L -14.00R	LOWER CAP WITH CARGO SLING	0.50	1.00	10			
	136.18 -138.73	40.41	14.00L -14.00R	LOWER CAP COVER	1.35	2.70	10			
	136.18 -138.73	FROM 54.89 TO -40.41	14.00L&R	END SUPPORTS, ZEE SECTION	0.25	0.50	10			
	137.56	55.30	0.00	LIFT LINK AND ATTACHMENT	NO DAMAGE ALLOWED					
	137.56	39.00	0.00	CARGO SLING FITTING	NO DAMAGE ALLOWED IF FITTING IS USED FOR CARGO					
5TH MOUNT	153.45	FROM 67.50 TO -63.87	14.00L -14.00R	FITTING	NO DAMAGE ALLOWED					
CLIPS	178.00	22.00	14.00L&R	TENSION TIE	NO DAMAGE TO CLIPS					

Table 4-3. Damage Limits Fuselage, Midsection (FS 129 to 178) - Condition I (Cont)

COMPONENT/ MEMBER	LOCATION			ELEMENT	DAMAGE LIMITS					FIGURE 4-1 AND NOTES
	FS	WL	BL		CAP/FLANGE			SKIN/WEB		
					CD'	CL'	N	WL'	N	
FITTING	129.00	FROM 26.00 TO -14.00	14.00L&R	SPLICE	(D' = NxCL)			(D' = NxWL)		
FITTING, EXTERNAL STORES	155.00	11.00	35.54L&R	LOWER FITTING	0.40	0.80	10		NO DAMAGE ALLOWED IF FITTING USED IS FOR EXTERNAL STORES	
	129.00	9.60	36.97L&R	LOWER FITTING						
	129.00 155.00	20.24	45.95L&R	UPPER FITTINGS						
LANDING GEAR	163.00	12.00	14.00L&R	AFT FITTING					NO DAMAGE ALLOWED	

Table 4-4. Damage Limits Fuselage, Aft (FS 178 to 243) - Condition I

COMPONENT/ MEMBER	LOCATION			ELEMENT	DAMAGE LIMITS					FIGURE 4-1 AND NOTES	
	FS	WL	BL		CAP/FLANGE			SKIN/WEB			
					CD'	CL'	N	WL'	N		
AFT FUSELAGE	178.00 -211.06		c-OUTBD L&R	SKIN	(D' = NxCL)			(D' = NxWL)	2.50	5	
	211.06 -243.89		c-OUTBD L&R	SKIN					5.00	5	
	178.00 202.00		14.00L&R	ACCESS DOOR					5.00	5	NO DAMAGE WITHIN 1.5 INCH OF EDGE
DECKS	178.00 239.00	54.89	14.00L&R	HONEYCOMB PANEL					6.00	5	

Table 4-4. Damage Limits Fuselage, Aft (FS 178 to 243) - Condition I (Cont)

COMPONENT/ MEMBER	LOCATION			ELEMENT	DAMAGE LIMITS				FIGURE 4-1 AND NOTES	
	FS	WL	BL		CAP/FLANGE			SKIN/WEB		
					CD'	CL'	N	WL'		N
DECKS	200.00	54.89	C SHIP	ENGINE MOUNT ATTACHMENT	NO DAMAGE ALLOWED					
				ANTI-TORQUE SUPPORT						
	178.00 239.00	54.89	14.00L&R	EDGE HONEYCOMB PANEL	1.00	5.00	10			
MAIN BEAMS	192.00	22.00	14.00L&R	BEAM CAP	.30	.60	10			
	178.00	22.00	14.00L&R	CONTOUR BEAM CAP	.14	.28	10			
	211.06	54.89	14.00L&R	BEAM CAP	.45	.90	10			
	211.06 243.89	22.00	14.00L&R	LOWER CAP	.10	.20	10			
	178.00 211.06	22.00	14.00L&R	LOWER CAP	.10	.20	10			
	178.00 211.06	22.00- LOWER CONTOUR		WEB				1.75	5	
	211.06		14.00L&R	OUTBOARD ANGLE	.30	.60	10			
	214.23 241.20	FROM 54.89 TO 22.00		TENSION ROD	NO DAMAGE ALLOWED					

Table 4-4. Damage Limits Fuselage, Aft (FS 178 to 243) - Condition I (Cont)

COMPONENT/ MEMBER	LOCATION			ELEMENT	DAMAGE LIMITS					FIGURE 4-1 AND NOTES
	FS	WL	BL		CAP/FLANGE			SKIN/WEB		
					CD'	CL'	N	WL'	N	
MAIN BEAMS	211.06 243.89	FROM		WEB	NO DAMAGE ALLOWED					
		54.89 TO 22.00								
BULKHEADS	178.00	FROM	c -14.00 L&R	LOWER WEB	NO DAMAGE ALLOWED					DOES NOT INCLUDE HOLES
		22.00 TO 12.40								
	178.00	22.00	14.00L&R	HOR STIFFENER	.3	.6	10			
	211.06	FROM 54.89 TO 19.40	14.00L&R	STIFFENER	NO DAMAGE ALLOWED					
	211.06	FROM 27.30 TO 19.40	9.70L 4.80R	OIL COVER SUPPORT						
	211.06	FROM 36.72 TO 29.84	6.30 14.00	ANTI-TORQUE BOOST CYL SUPPORT						
	211.06	36.72		SKIN AND EDGE DOUBLER						
	243.85			BOLT HOLE FITTINGS	NO DAMAGE ALLOWED					
TAIL BOOM ATTACHMENT	243.85	59.78	11.31	UPPER RIGHT- HAND FITTING						
	211.06	54.89	14.00	CAP SPLICE FITTINGS						

Table 4-4. Damage Limits Fuselage, Aft (FS 178 to 243) - Condition I (Cont)

COMPONENT/ MEMBER	LOCATION			ELEMENT	DAMAGE LIMITS				FIGURE 4-1 AND NOTES	
	FS	WL	BL		CAP/FLANGE			SKIN/WEB		
					CD'	CL'	N	WL'		N
JACKING FITTINGS	211.06		14.00L&R	FITTINGS	(D'=NxCL)			(D'=NxWL)		DO NOT JACK IF DAMAGED AREA WILL NOT SUPPORT HELICOPTER
TIE DOWN	211.06		14.00L&R	FITTINGS	DO NOT USE IF DAMAGED					
AFT ENGINE MOUNT	200.00	54.89	14.00	FITTINGS	NO DAMAGE ALLOWED					
	178.00	54.89	14.00	SUPPORT						

Table 4-5. Damage Limits Tail Boom - Condition I

COMPONENT/ MEMBER	LOCATION			ELEMENT	DAMAGE LIMITS				FIGURE 4-1 AND NOTES	
	FS	WL	BL		CAP/FLANGE			SKIN/WEB		
					CD'	CL'	N	WL'		N
TAIL BOOM	FROM 17.37 TO -194.30			UPPER RIGHT ANGLE	.50	1.00	5	(D'=NxWL)		ITEM 1, FIG 4-1 SHEET 13 OF
	FROM 17.37 TO -194.30			UPPER RIGHT LONGERON	1.75	3.50	5			
	FROM 17.37 TO -194.30			UPPER RIGHT STRINGER	.44	.88	5			
	FROM 17.37 TO -194.30			LOWER RIGHT STRINGER	.26	.52	5			
	FROM 17.37 TO -194.30			LOWER RIGHT LONGERON	1.27	2.54	5			

Table 4-5. Damage Limits Tail Boom - Condition I (Cont)

COMPONENT/ MEMBER	LOCATION			ELEMENT	DAMAGE LIMITS				FIGURE 4-1 AND NOTES
					CAP/FLANGE			SKIN/WEB	
	FS	WL	BL		CD'	CL'	N	WL'	
TAIL BOOM	FROM 17.37 TO -194.30			BOTTOM MIDDLE STRINGER	(D'=NxCL)			(D'=NxWL)	
	FROM 17.37 TO -59.05			LOWER LEFT LONGERON	NO DAMAGE ALLOWED				
	FROM 59.05 TO -194.30			LOWER LEFT LONGERON	2.90	5.80	10		
	FROM 17.37 TO -194.30			LOWER LEFT STRINGER	.52	1.04	5		
	FROM 17.37 TO -194.30			UPPER LEFT STRINGER	1.20	2.40	5		
	FROM 17.37 TO -194.30			UPPER LEFT LONGERON	2.77	5.54	10		
	FROM 17.37 TO -194.30			UPPER LEFT ANGLE	.58	1.16	5		
	FROM 17.37 TO -38.43			TOP RIGHT STRINGER	1.13	2.26	5		
	FROM 17.37 TO -38.43			MIDDLE UPPER RIGHT STRINGER	.86	1.72	5		
	FROM 17.37 TO -38.43			MIDDLE RIGHT STRINGER	.60	1.20	5		
	FROM 17.37 TO -38.43			MIDDLE LOWER RIGHT STRINGER	.47	.94	5		

Table 4-5. Damage Limits Tail Boom - Condition I (Cont)

COMPONENT/ MEMBER	LOCATION			ELEMENT	DAMAGE LIMITS					FIGURE 4-1 AND NOTES
	FS	WL	BL		CAP/FLANGE			SKIN/WEB		
					CD'	CL'	N	WL'	N	
					(D'=NxCL)			(D'=NxWL)		
TAIL BOOM	FROM 17.37 TO -38.43			LOWER RIGHT ANGLE	.48	.96	5			
	FROM 17.37 TO -38.43			BOTTOM RIGHT STRINGER	.49	.98	5			
	FROM 80.44 TO -101.38			BOTTOM RIGHT ANGLE	.78	1.56	5			
	FROM 17.37 TO -38.43			BOTTOM LEFT INBOARD ANGLE	.50	1.00	5			
	FROM 80.44 TO -101.38			BOTTOM LEFT INBOARD ANGLE	.92	1.84	5			
	FROM 17.37 TO -38.43			BOTTOM LEFT INBOARD ANGLE	.50	1.00	5			
	FROM 80.44 TO -101.38			BOTTOM LEFT OUTBD STRINGER	.98	1.96	5			
	FROM 38.43 TO -59.50			BOTTOM LEFT INBOARD STRINGER	.71	1.42	5			
	FROM 101.38 TO -122.33			BOTTOM LEFT INBOARD STRINGER	.90	1.80	5			
	FROM 17.38 TO -59.50			BOTTOM LEFT OUTBD STRINGER	.50	1.00	5			
	FROM 101.38 TO -122.33			BOTTOM LEFT OUTBD STRINGER	.98	1.96	5			

Table 4-5. Damage Limits Tail Boom - Condition I (Cont)

COMPONENT/ MEMBER	LOCATION			ELEMENT	DAMAGE LIMITS				FIGURE 4-1 AND NOTES	
	FS	WL	BL		CAP/FLANGE			SKIN/WEB		
					CD' (D'=NxCL)	CL'	N	WL'		N
BULKHEAD				INNER FLANGE	.42	.84	5			
				WEB				.23	10	
	80.44			OUTER FLANGE	.56	1.12	5			
				INNER FLANGE	.50	1.00	5			
				WEB				.43	10	
	101.33			OUTER FLANGE	1.00	2.00	5			
	101.33			INNER FLANGE	.60	1.20	5			
				WEB				.63	10	
	122.33			OUTER FLANGE	1.00	2.00	5			
				INNER FLANGE	.63	1.26	5			
				WEB				.83	10	

Table 4-5. Damage Limits Tail Boom - Condition I (Cont)

COMPONENT/ MEMBER	LOCATION			ELEMENT	DAMAGE LIMITS				FIGURE 4-1 AND NOTES	
	FS	WL	BL		CAP/FLANGE			SKIN/WEB		
					CD'	CL'	N	WL'		N
					(D' = N x CL)			(D' = N x WL)		
TAIL BOOM	FROM 17.37 TO -38.43			MIDDLE LOWER LEFT STRINGER	.52	1.04	5			
	FROM 17.37 TO -38.43			MIDDLE LEFT STRINGER	.93	1.86	5			
	FROM 17.37 TO -38.43			MIDDLE UPPER LEFT STRINGER	1.75	3.50	5			
	FROM 17.37 TO -38.43			TOP LEFT STRINGER	2.60	5.20	5			
BULKHEAD	17.37			OUTER FLANGE	NO DAMAGE ALLOWED					
				INNER FLANGE	.3	.6	5			
	17.37			WEB	NO DAMAGE ALLOWED					
	38.43			OUTER FLANGE						
				INNER FLANGE	.35	.7	5			
				WEB	NO DAMAGE ALLOWED					
	59.50			OUTER FLANGE	.33	.66	5			

Table 4-5. Damage Limits Tail Boom - Condition I (Cont)

COMPONENT/ MEMBER	LOCATION			ELEMENT	DAMAGE LIMITS				FIGURE 4-1 AND NOTES	
	FS	WL	BL		CAP/FLANGE			SKIN/WEB		
					CD'	CL'	N	WL'		N
BULKHEAD	143.28			OUTER FLANGE	1.25	2.50	5			
				INNER FLANGE	.70	1.40	5			
				WEB				1.00	10	
	164.23			OUTER FLANGE	1.50	3.00	5			
				INNER FLANGE	.92	1.84	5			
				WEB				1.00	10	
	185.18			OUTER FLANGE	1.75	3.50	5			
				INNER FLANGE	1.14	2.28	5			
				WEB				1.00	10	
	194.30			OUTER FLANGE	2.00	4.00	5			
				INNER FLANGE	1.40	2.80	5			

Table 4-5. Damage Limits Tail Boom - Condition I (Cont)

COMPONENT/ MEMBER	LOCATION			ELEMENT	DAMAGE LIMITS				FIGURE 4-1 AND NOTES
					CAP/FLANGE			SKIN/WEB	
	BS	WL	BL		CD'	CL'	N	WL'	
BULKHEAD				WEB				1.00 10	
VERTICAL FIN	FS 5.08 -99.05			FORWARD SPAR	.44	.88	10		
	FS 5.08 -59.05			AFT SPAR	4.05	8.10	10		
	FS 10.03 -59.05			STRINGER	MAY BE SEVERED AT ONE LOCATION, BETWEEN RIBS, & 50% X-SECTION CRACKED AT OTHER LOCATIONS ALONG STRINGER				
	BETWEEN FORWARD AND AFT SPARS			SKIN				3.1 1.5	
	AFT SPAR TO TRAILING EDGE			SKIN				6.2 1.5	
	FS 5.08 -59.05			TAIL ROTOR DRIVE SHAFT COVER				NOTE (2)	
	AFT OF 194.03			SKIN				3.1 1.5	
	BETWEEN FORWARD AND AFT SPARS			RIBS	RIBS MAY HAVE UP TO 50% X-SECTION CRACKED, UP TO TWO NON-ADJACENT RIBS MAY BE SEVERED, AND UP TO 50% X-SECTION MAY BE CRACKED ON ANY RIB				
	AFT SPAR TRAILING EDGE			RIBS					

Table 4-5. Damage Limits Tail Boom - Condition I (Cont)

COMPONENT / MEMBER	LOCATION			ELEMENT	DAMAGE LIMITS				FIGURE 4-1 AND NOTES	
	BS	WL	BL		CAP/FLANGE			SKIN/WEB		
					CD'	CL'	N	WL'		N
VERTICAL FIN	227.00			BULKHEAD	(D' = N x CL)			(D' = N x WL)		
	194.30 -227.00			ANGLE	.50	1.00	10			
	194.30 -227.00			STRINGERS, CHANNELS	.51	1.02	10			
				42° GEARBOX MOUNT	NO DAMAGE ALLOWED					
				90° GEARBOX MOUNT						
				TRAILING EDGE	NO LIMIT ON DAMAGE TO ELEMENT					
	194.30 -227.00			42° GEARBOX COVER						
	194.30 -FWD SPAR			UPPER LEFT LONGERON	2.77	5.54	10			
	194.30 -FWD SPAR			LOWER LEFT LONGERON	3.74	7.48	10			
	194.30 -FWD SPAR			UPPER RIGHT LONGERON	3.08	6.16	10			
	194.30 -FWD SPAR			LOWER RIGHT LONGERON	2.63	5.26	10			

Table 4-6. Damage Limits Cabin Roof - Condition II

COMPONENT/ MEMBER	LOCATION			ELEMENT	MAX DAMAGE LIMITS ALLOWED					FIGURE 4-1 AND NOTES
	FS	WL	BL		CAP/FLANGE			SKIN/WEB		
					CD'	CL'	N	WL'	N	
DOOR POST	74.25	FROM 22.00 TO 78.00		POST R/H & L/H	.50	1.00	5			
	63.38	FROM 22.00 TO -69.00		POST R/H & L/H	.83	1.66	5			
	63.38	FROM 69.00 TO -71.00		SPLICE R/H & L/H						1 RIVET DAMAGED
	63.38	FROM 71.00 TO -78.00		POST R/H & L/H	.83	1.66	5			
	63.38 -74.25	FROM 22.00 TO -78.00	34.10- OUTBD	WEB R/H & L/H						2 WEBS SEVERED
	63.38 -74.25	FROM 22.00 TO -78.00		SKIN	NO LIMIT ON DAMAGE TO ELEMENT					
BULKHEAD	112.80	80.00	15.25L&R	UPPER FLANGE	.40	.80	5			
	112.80	FROM 75.60 TO 80.00	15.25L&R	WEB	2.80	5.60	5			
	81.00 83.00	FROM 75.00 TO 80.00	30.00L&R OUTBD	FRAME	2.22	4.44	5			
	63.38	FROM 75.60 TO 80.00	31.25L&R	FRAME	.40	.80	5			
	63.38	FROM 75.60 TO 80.00	31.25L&R OUTBD	FRAME	1.30	2.60	5			

Table 4-6. Damage Limits Cabin Roof - Condition II (Cont)

COMPONENT/ MEMBER	LOCATION			ELEMENT	MAX DAMAGE LIMITS ALLOWED					FIGURE 4-1 AND NOTES
	FS	WL	BL		CAP/FLANGE			SKIN/WEB		
					CD'	CL'	N	WL'	N	
BULKHEAD	74.25	80.00	16.00L&R	UPPER FLANGE	(D'=NxCL)			(D'=NxWL)		
	74.25	FROM 75.60 TO -80.00	16.00L&R	WEB	.40	.80	5			
	92.00	80.00	16.00L&R	UPPER FLANGE	.40	.80	5			
	92.00	FROM 75.60 TO -80.00	16.00L&R	WEB	1.80	3.60	5			
	74.25	FROM 75.60 TO -80.00	30.00L&R OUTBD	CAP	2.22	4.44	5			
	92.00	FROM 75.60 TO -80.00	30.00L&R OUTBD	FRAME	2.22	4.44	5			
	74.25	FROM 75.60 TO -80.00	16.00 -30.00L&R	FRAME	1.75	3.50	5			
	92.00	FROM 75.60 TO -80.00	16.00 -30.00L&R	FRAME	1.95	3.90	5			
	157.50 -159.50	FROM 75.00 TO -80.00	30.00L&R OUTBD	FRAME	2.30	4.60	5			
	130.01 -132.01	FROM 75.00 TO -80.00	30.00L&R OUTBD	FRAME	2.30	4.60	5			
	104.00 -106.00	FROM 75.00 TO -80.00	30.00L&R OUTBD	FRAME	2.25	4.50	5			

Table 4-6. Damage Limits Cabin Roof - Condition II (Cont)

COMPONENT / MEMBER	LOCATION			ELEMENT	MAX DAMAGE LIMITS ALLOWED					FIGURE 4-1 AND NOTES
	FS	WL	BL		CAP/FLANGE			SKIN/WEB		
					CD'	CL'	N	WL'	N	
BULKHEAD	114.71	FROM 75.00 TO -80.00	30.00L&R OUTBD	FRAME	(D'=NxCL)			(D'=NxWL)		
	142.00	FROM 75.00 TO -80.00	30.00L&R OUTBD	FRAME	2.00	4.00	5			
	148.00	FROM 75.00 TO -50.00	30.00L&R OUTBD	FRAME	2.00	4.00	5			
LONGERON	63.38 -126.97	FROM 75.60 TO -80.00	15.25L&R	FRAME	.90	1.80	5			
	74.25 -114.71	FROM 75.60 TO -80.00	30.00L&R	FRAME	1.90	3.80	5			
	114.71 -131.80	FROM 75.60 TO -80.00	30.00L&R	FRAME	1.15	2.30	5			
	131.80 -166.00	FROM 75.60 TO -80.00	30.00L&R	FRAME	1.92	3.84	5			
	63.38 -74.25	FROM 75.60 TO -80.00	30.00L&R	FRAME	1.15	2.30	5			
	126.97 -166.00	FROM 75.60 TO -80.00	15.25L&R	FRAME	.94	1.88	5			
DOOR POST	157.50 -159.50	FROM 75.00 TO -80.00	37.00L 39.00R	SUPPORT BRACKET	.66	1.32				ONE DAMAGE
	81.00 -83.00	FROM 75.00 TO -80.00	34.10L 36.10R	SUPPORT BRACKET	.66	1.32				ONE DAMAGE

Table 4-6. Damage Limits Cabin Roof - Condition II (Cont)

COMPONENT/ MEMBER	LOCATION			ELEMENT	MAX DAMAGE LIMITS ALLOWED					FIGURE 4-1 AND NOTES
	FS	WL	BL		CAP/FLANGE			SKIN/WEB		
					CD'	CL'	N	WL'	N	
DOOR POST	130.01 -132.01	FROM 75.00 TO -80.00	38.50 -40.50L&R	SUPPORT BRACKET	(D'=NxCL)			(D'=NxWL)		ONE DAMAGE
	104.00 -106.00	FROM 75.00 TO -80.00	34.10 -36.10L&R	SUPPORT BRACKET	.24	.48				ONE DAMAGE
DOORS	63.38 -166.00	72.60		CARGO DOOR RAIL	NO LIMIT ON DAMAGE TO ELEMENT					
	166.00			CARGO DOOR						
	74.25	FROM 22.00 TO -78.00		HINGED PANEL DOOR						
ROOF PANEL RIVETS	63.38 -126.97	80.00	12.25 -16.00L&R	PANEL EDGE	.94	1.88	5			
	80.00 -84.00	80.00	9.00 -13.1L&R	STN RIVETS						5 RIVETS DAMAGED
	63.38	80.00	-16.00L&R	CP RIVETS						12 RIVETS DAMAGED
	63.38 -66.38	80.00	-12.25L&R	PANEL EDGE	.44	.88	5			
	80.00 -84.00	80.00	-12.25L&R	CENTER PANEL	4.00	8.00	5			
	98.00 -102.00	80.00	-12.25L&R	CENTER PANEL	4.60	9.20	5			

Table 4-6. Damage Limits Cabin Roof - Condition II (Cont)

COMPONENT/ MEMBER	LOCATION			ELEMENT	MAX DAMAGE LIMITS ALLOWED				FIGURE 4-1 AND NOTES	
	FS	WL	BL		CAP/FLANGE			SKIN/WEB		
					CD'	CL'	N	WL'		N
ROOF PANEL/ RIVETS	66.38 -80.00	80.00	-12.25L&R	CENTER PANEL	(D'=NxCL)			15.2 5		
	84.00 -98.00	80.00	-12.25L&R	CENTER PANEL				15.2 5		
	102.00 -126.97	80.00	-12.25L&R	CENTER PANEL				15.2 5		
	63.38 -166.00	80.00	-30.00L&R	ROOF PANEL	NO LIMIT ON DAMAGE TO ELEMENT					
	63.38 -166.00	80.00	16.00 -30.00L&R	ROOF PANEL						

Table 4-7. Damage Limits Fuselage, Forward (FS 23 to 129) - Condition II

COMPONENT/ MEMBER	LOCATION			ELEMENT	MAX DAMAGE LIMITS ALLOWED				FIGURE 4-1 AND NOTES	
	BS	WL	BL		CAP/FLANGE			SKIN/WEB		
					CD'	CL'	N	WL'		N
FORWARD SECTION, BOTTOM	102.00 -129.00	BOTTOM -22.00	34.70L&R -OUTBD	SKIN	(D'=NxCL)			4.00 5	CRITICAL WITH EXTERNAL STORES	
	23.00 -102.00	BOTTOM -22.00	c - OUTBD L&R	SKIN					SKIN NOT CRITICAL	
	102.00 -129.00	BOTTOM	34.70L&R	SKIN						
DECKS	63.33 -129.00	22.00	c - OUTBD L&R	CARGO TIEDOWN FITTINGS	DO NOT USE FITTINGS WITH DAMAGE WITHIN 3 INCHES OF FITTINGS					

Table 4-7. Damage Limits Fuselage, Forward (FS 23 to 129) - Condition II (Cont)

COMPONENT/ MEMBER	LOCATION			ELEMENT	MAX DAMAGE LIMITS ALLOWED				FIGURE 4-1 AND NOTES	
	BS	WL	BL		CAP/FLANGE			SKIN/WEB		
					CD'	CL'	N	WL'		N
DECKS	74.25 -123.00	22.00	14.00L&R	DOOR ASSEMBLY, HONEYCOMB				(D'=NxWL)	13.00 5	NO DAMAGE WITHIN 1.5 INCH OF EDGE
	74.25 -123.00	22.00	14.00L&R	EDGE, HONEYCOMB PANEL	1.00	5.00	5			
	23.00 -74.00	22.00	c - OUTBD L&R	HONEYCOMB PANEL					12.00 5	NO DAMAGE WITHIN 1.5 INCH OF EDGE
	23.00 -74.00	22.00	c - OUTBD L&R	EDGE, HONEYCOMB PANEL	1.00	5.00	5			
	74.22 -129.00	22.00	14.00L&R -OUTBDR	HONEYCOMB PANEL					12.00 5	NO DAMAGE WITHIN 1.5 INCH OF EDGE
	123.06 -128.75	22.00	14.00L&R	ENDS, HONEYCOMB PANEL	1.00	3.00	5			
	123.00 -128.75	22.00	14.00L&R	HONEYCOMB PANEL					3.00 5	NO DAMAGE WITHIN 1.5 INCH OF EDGE
MAIN BEAM	112.50	22.00	14.00L 14.00R	UPPER CAP SPLICE INSIDE & OUTSIDE	1.10	2.20	5			
	23.00 -41.70	22.00	14.00L 14.00R	UPPER CAP	1.40	2.80	5			
	41.70 -69.00	22.00	14.00L 14.00R	UPPER CAP	1.50	3.00	5			
	69.00 -83.80	22.00	14.00L 14.00R	UPPER CAP	1.00	2.00	5			

Table 4-7. Damage Limits Fuselage, Forward (FS 23 to 129) - Condition II (Cont)

COMPONENT/ MEMBER	LOCATION			ELEMENT	MAX DAMAGE LIMITS ALLOWED					FIGURE 4-1 AND NOTES
	BS	WL	BL		CAP/FLANGE			SKIN/WEB		
					CD'	CL'	N	WL'	N	
MAIN BEAM	83.80	22.00	14.00L&R	UPPER CAP	(D' = NxCL)			(D' = NxWL)		
	-95.50				1.80	3.60	5			
	95.50	22.00	14.00L&R	UPPER CAP	1.10	2.20	5			
	23.00	BOTTOM CONTOUR	14.00L&R	LOWER CAP	0.70	1.40	5			
	34.00	LOWER CONTOUR	14.00L&R	LOWER CAP	0.70	1.40	5			
	60.00	LOWER CONTOUR	14.00L&R	LOWER CAP	0.75	1.50	5			
	73.50	LOWER CONTOUR	14.00L&R	LOWER CAP	0.75	1.50	5			
	78.07	LOWER CONTOUR	14.00L&R	LOWER CAP	1.50	3.00	5			
	117.00	LOWER CONTOUR	14.00L&R	LOWER CAP	1.55	3.10	5			
	69.00	LOWER CONTOUR	14.00L&R	CROSS TUBE FITTING	NO DAMAGE ALLOWED					
	47.60	FROM 12.00 TO -22.00	14.00L&R	STIFFENER	0.85	1.70	5			
	63.33	FROM 9.90 TO -22.00	14.00L&R	STIFFENER	2.60	5.20	5			

Table 4-7. Damage Limits Fuselage, Forward (FS 23 to 129) - Condition II (Cont)

COMPONENT/ MEMBER	LOCATION			ELEMENT	MAX DAMAGE LIMITS ALLOWED				FIGURE 4-1 AND NOTES	
	BS	WL	BL		CAP/FLANGE			SKIN/WEB		
					CD'	CL'	N	WL'		N
MAIN BEAM	69.00	FROM 9.90 TO -22.00	14.00L&R	STIFFENER	(D'=NxCL)			(D'=NxWL)		
		2.40			4.80	5				
	74.30	FROM 9.90 TO -22.00	14.00L&R	STIFFENER	2.45	4.90	5			
	90.00	FROM 9.90 TO -22.00	14.00R	STIFFENER	0.85	1.70	5			
	102.00 -129.00	FROM 9.90 TO -22.00	14.00L&R	HONEYCOMB PANEL				10.00	5	
	23.00 -37.00	FROM 10.90 TO -22.00	14.00L&R	WEB				11.00	5	
	37.00 -47.60	FROM 10.00 TO -22.00	14.00L	WEB				7.75	5	
	37.00 -47.60	FROM 10.00 TO -22.00	14.00R	WEB				3.70	5	
	47.00 -69.00	FROM 9.00 TO -22.00	14.00L	WEB				5.25	5	
	47.00 -69.00	FROM 9.00 TO -22.00	14.00R	WEB				3.80	5	
	69.00 -74.30	FROM 8.00 TO -22.00	14.00L&R	WEB				3.50	5	
	74.30 -78.10	FROM 7.44 TO -22.00	14.00L&R	WEB				9.55	5	

INCLUDES ACCESS HOLES

Table 4-7. Damage Limits Fuselage, Forward (FS 23 to 129) - Condition II (Cont)

COMPONENT/ MEMBER	LOCATION			ELEMENT	MAX DAMAGE LIMITS ALLOWED				FIGURE 4-1 AND NOTES		
	BS	WL	BL		CAP/FLANGE			SKIN/WEB			
					CD'	CL'	N	WL'		N	
MAIN BEAM	78.10 -102.00	FROM 7.44 TO -22.00	14.00L&R	WEB				4.00	5	INCLUDES ACCESS HOLES	
BULKHEAD	63.33	22.00	c - L&R OUTBD	UPPER CAP	1.25	2.50	5				
	63.33	LOWER CONTOUR	c - L&R OUTBD	LOWER CAP	0.75	1.50	5				
	63.33	LOWER CONTOUR	30.00L&R	LOWER CAP	JACK ONLY IF CAP WILL SUPPORT HELICOPTER						
	63.33	LOWER CONTOUR	14.00L&R	SPLICE PLATE	1.10	2.20	5				
	63.33	FROM 7.44 TO -22.00	c - L&R OUTBD	WEB				5.35	5	INCLUDES ACCESS HOLES	
	74.30	LOWER CONTOUR	c - L&R OUTBD	LOWER CAP	1.20	2.40	5				
	74.30	LOWER CONTOUR	14.00L&R	SPLICE	2.65	5.30	5				
	74.30	FROM 7.44 TO -22.00	c - L&R OUTBD	WEB				6.60	5	INCLUDES ACCESS HOLES	
	74.30	22.00	c - L&R OUTBD	UPPER CAP	1.00	2.00	5				
BULKHEADS	23.00 37.00	BOTTOM CONTOUR 22.00	c - L&R OUTBD	UPPER & LOWER CAPS	*	2XCD	5			*50% OF CROSS- SECTIONAL AREA	

Table 4-7. Damage Limits Fuselage, Forward (FS 23 to 129) - Condition II (Cont)

COMPONENT/ MEMBER	LOCATION			ELEMENT	MAX DAMAGE LIMITS ALLOWED			FIGURE 4-1 AND NOTES		
	BS	WL	BL		CAP/FLANGE				SKIN/WEB	
					CD'	CL'	N		WL'	N
BULKHEADS	52.00									
	69.00									
	84.50 102.00									
	23.00 37.00	BOTTOM CONTOUR -22.00	c - L&R OUTBD	WEBS	*		5	*70% OF ANY SECTION		
	52.00 69.00									
	84.50 102.00									
SEAT RAILS	41.00 -51.00	22.00	14.00L&R 30.00L&R	SEAT TRACK (FORWARD)	1.00	2.00	5			
	55.70 -63.33	22.00	14.00L&R 30.00L&R	SEAT TRACK (AFT)	0.75	1.50	5			
SEAT SUPPORT BEAM	37.00 -63.33	22.00	14.00L&R 30.00L&R	SEAT TRACK SUPPORT (CAP)	1.40	2.80	5			
	37.00 -63.00	LOWER CONTOUR	30.00L&R	LOWER CAP	1.05	2.10	5			
	37.00 -63.00	LOWER CONTOUR	30.00L&R	VERTICAL STIFF- ENERS (CHANNELS)	2.30	4.60	5			
	63.33	LOWER CONTOUR	30.00L&R	JACK FITTING & BACKUP STRUCTURE	DO NOT JACK IF DAMAGED AREA WILL NOT SUPPORT HELICOPTER					

Table 4-7. Damage Limits Fuselage, Forward (FS 23 to 129) - Condition II (Cont)

COMPONENT/ MEMBER	LOCATION			ELEMENT	MAX DAMAGE LIMITS ALLOWED				FIGURE 4-1 AND NOTES	
	BS	WL	BL		CAP/FLANGE			SKIN/WEB		
					CD'	CL'	N	WL'		N
PEDAL SUPPORT	23.00 -29.08	14.75	19.16L&R	STIFFENERS	(D'=NxCL)			(D'=NxWL)		
	34.75 -37.00	FROM 12.00 TO -22.00	19.16L&R	PEDAL ADJUSTER SUPPORT	0.55	1.10	5			
	23.00 -37.00	22.00	19.16L&R	CAP	0.75	1.50	5			
JACKING & MOORING FITTINGS	62.78	LOWER CONTOUR	30.00L&R	FITTING	DO NOT USE IF FURTHER DAMAGE WILL OCCUR					
LANDING GEAR	71.60	9.90	14.00L&R	FITTING	0.55	1.10	5			

Table 4-8. Damage Limits Fuselage, Midsection (FS 129 to 178) - Condition II

COMPONENT/ MEMBER	LOCATION			ELEMENT	MAX DAMAGE LIMITS ALLOWED				FIGURE 4-1 AND NOTES	
	BS	WL	BL		CAP/FLANGE			SKIN/WEB		
					CD'	CL'	N	WL'		N
MIDSECTION, BOTTOM	129.00 -155.00	LOWER CONTOUR	34.70L&R -OUTBD	SKIN	(D'=NxCL)			(D'=NxWL)		
	155.00 -178.00	LOWER CONTOUR	c - L&R -OUTBD	SKIN				4.00	5	WITH EXTERNAL STORES
	102.00 -155.06	LOWER CONTOUR	14.00L -34.70R	HONEYCOMB PANEL				12.00	5	NO DAMAGE WITHIN 1.5 INCH OF EDGE
	129.00 -155.06	LOWER CONTOUR	14.00L&R	HONEYCOMB PANEL				12.00	5	

Table 4-8. Damage Limits Fuselage, Midsection (FS 129 to 178) - Condition II (Cont)

COMPONENT/ MEMBER	LOCATION			ELEMENT	MAX DAMAGE LIMITS ALLOWED				FIGURE 4-1 AND NOTES	
	BS	WL	BL		CAP/FLANGE			SKIN/WEB		
					CD'	CL'	N	WL'		N
HOIST MAINTENANCE SUPPORT	157.70	22.00	26.00L	UPPER SKIN	(D'=NxCL) (D'=NxWL)				IF FLOOR SUPPORT IS DAMAGED, USE CARE WHEN USING HOIST	
	157.70	22.00	26.00L	DOUBLER						
MIDSECTION FLOOR	166.00 -178.00	FROM 22.00 TO -25.58	14.00L&R -OUTBD	HONEYCOMB PANEL				9.00 5	NO DAMAGE WITHIN 1.5 INCH OF EDGE	
	155.00 -178.00	22.00	14.00L&R	HONEYCOMB PANEL				12.00 5		
	129.00 -166.00	22.00	14.00L&R -OUTBD	HONEYCOMB PANEL				12.00 5		
	129.00 -166.00	22.00		HONEYCOMB PANEL EDGES	1.00	7.00	5			
MIDSECTION	166.00	FROM 22.00 TO -54.89	14.00L&R	FRAME CHANNEL AND ANGLE	2.00	4.00	5			
	155.00 160.00 166.00 178.00	FROM 22.00 TO -54.89	14.00L&R	VERTICAL ANGLES	0.75	1.50	5		EACH ANGLE	
	152.75 -166.00	FROM 54.68 TO -68.64	14.00L&R	AFT, LOWER DOOR HONEYCOMB				10.60 5		
	158.00	61.00	14.00L&R	LITTER SUPPORT PLATE	DO NOT USE IF DAMAGE IS EXCESSIVE					
	129.00 -136.90	FROM 39.60 TO -54.90	14.00L&R	HONEYCOMB PANEL				3.70 5		

Table 4-8. Damage Limits Fuselage, Midsection (FS 129 to 178) - Condition II (Cont)

COMPONENT / MEMBER	LOCATION			ELEMENT	MAX DAMAGE LIMITS ALLOWED					FIGURE 4-1 AND NOTES
	BS	WL	BL		CAP/FLANGE			SKIN/WEB		
					CD'	CL'	N	WL'	N	
					(D' = NxCL)			(D' = NxWL)		
MIDSECTION	129.00	22.00 -39.60	14.00L&R	DOOR SKIN				12.00	5	
	129.00	39.60 -54.00	14.00L&R	SKIN BEYOND DOOR DOUBLER	0.85	1.70	5			
	129.00	41.60 -50.60	c -10.00L	DOOR DOUBLER & SKIN	1.10	2.20	5			
BULKHEAD	129.00	54.02 -65.86	14.00L&R	WEB, CANTED				10.00	5	
	155.00	22.00 -54.89	14.00L&R	CENTER PANEL				15.00	5	
	155.00	22.00	14.00L&R	TENSION FITTINGS	NO DAMAGE ALLOWED					
	166.00	22.00 LOWER CONTOUR	30.00L&R -OUTBD	WEB, OUTER				1.5	5	DOES NOT INCLUDE LIGHTENING HOLES
	166.00	22.00 LOWER CONTOUR	c 30.00L&R	WEB				3.50	5	
	166.00	22.00	14.00L&R	TENSION STRAP, VERTICAL	0.40	0.80	5			
	166.00	22.00	14.00L&R	TENSION STRAP, ACROSS BULKHEAD, UPPER	0.25	0.50	5			
	166.00	22.00 LOWER CONTOUR	14.00L&R	COMPRESSION STRAP, ACROSS BULKHEAD, LOWER	0.50	1.00	5			

Table 4-8. Damage Limits Fuselage, Midsection (FS 129 to 178) - Condition II (Cont)

COMPONENT/ MEMBER	LOCATION			ELEMENT	MAX DAMAGE LIMITS ALLOWED				FIGURE 4-1 AND NOTES	
	BS	WL	BL		CAP/FLANGE			SKIN/WEB		
					CD'	CL'	N	WL'		N
BULKHEAD	129.00	FROM 22.00 TO	14.00L&R	HONEYCOMB PANEL	(D'=NxCL)			(D'=NxWL)		NO DAMAGE WITHIN 1.5 INCH OF EDGE
	-155.00	-39.60						10.00	5	
	155.00	FROM 22.00 TO			14.00L&R	HONEYCOMB PANEL				
-178.00	-54.00									
	166.00	FROM 22.00 TO	14.00L&R OUTBD	HONEYCOMB PANEL				10.00 5		
	129.00	FROM 22.00 TO	c - L&R OUTBD	EDGE, HONEYCOMB PANELS	1.00	7.00	5			
	136.90	FROM 39.60 TO	14.00L&R	HONEYCOMB PANEL				5.00 5		NO DAMAGE WITHIN 1.5 INCH OF EDGE
	-155.06	-54.00								
MIDSECTION BEAM, LOWER	129.00	LOWER CONTOUR	14.00L&R	LOWER BEAM CAP	1.55	3.10	5			
	136.00	LOWER CONTOUR	14.00L&R	LOWER BEAM CAP	0.95	1.90	5			
	172.30	LOWER CONTOUR	14.00L&R	LOWER BEAM CAP	0.65	1.30	5			
	166.00	LOWER CONTOUR	14.00L&R	CROSS TUBE STRAP LOWER CAP	0.70	1.40	5			
	129.00	22.00 LOWER CONTOUR	14.00L&R	UPPER BEAM CAP	1.50	3.00	5			
	-178.00									
	102.00	22.00 LOWER CONTOUR	14.00L&R	HONEYCOMB PANEL				10.00 5		NO DAMAGE WITHIN 1.5 INCH OF EDGE
	-155.00									

Table 4-8. Damage Limits Fuselage, Midsection (FS 129 to 178) - Condition II (Cont)

COMPONENT / MEMBER	LOCATION			ELEMENT	MAX DAMAGE LIMITS ALLOWED						FIGURE 4-1 AND NOTES
	BS	WL	BL		CAP/FLANGE			SKIN/WEB			
					CD'	CL'	N	WL'	N		
MIDSECTION BEAM, LOWER	102.00 -155.00	22.00 LOWER CONTOUR	14.00L&R	EDGE, HONEYCOMB PANEL	(D'=NxCL)			(D'=NxWL)			
	155.00 -178.00	22.00 LOWER CONTOUR	14.00L&R	WEB	0.40	0.80	5	6.00	5	DOES NOT INCLUDE HOLES	
BEAM, LOWER	102.00 -155.06	LOWER CONTOUR	36.00L&R	INTERCOASTAL	0.70	1.40	5				
	102.00 -155.06	22.00 LOWER CONTOUR	36.00L&R	HONEYCOMB PANEL				8.90	5	DOES NOT INCLUDE HOLE	
	102.00 -155.00	22.00	36.00L&R	UPPER CAP	1.65	3.30	5				
MIDSECTION	136.90 -178.00	54.89	14.00L&R	BEAM CAP	1.60	3.20	5				
BULKHEADS	129.00 -134.00	22.00 LOWER CONTOUR	c - L&R OUTBD	UPPER & LOWER CAPS	*	2XCD	5			*50% OF CROSS-SECTIONAL AREA	
	155.00 -160.00										
PYLON SUPPORT	129.00 -155.00	54.89	14.00L&R	ZEE	1.75	3.50	5				
	131.82 -149.11	FROM 66.00 TO -67.57	10.25 -14.00L&R	ZEE	1.85	3.70	5			DOES NOT INCLUDE LIGHTENING HOLES	
	127.47 -153.45	FROM 65.92 TO -68.14	14.00L&R	ANGLE	0.65	1.30	5				

Table 4-8. Damage Limits Fuselage, Midsection (FS 129 to 178) - Condition II (Cont)

COMPONENT/ MEMBER	LOCATION			ELEMENT	MAX DAMAGE LIMITS ALLOWED				FIGURE 4-1 AND NOTES	
	BS	WL	BL		CAP/FLANGE			SKIN/WEB		
					CD'	CL'	N	WL'		N
PYLON SUPPORT	149.25	54.89	10.25 -14.44	TEE EXTRUSION	1.10	2.20	5			
	153.45	FROM 68.19 TO -67.59	9.80 -14.00	WEB (THRU RIVETS)	3.10	6.20	5			
	153.45	FROM 68.19 TO -54.89	14.00L&R	WEB				4.00 5	EACH SIDE	
	153.45	FROM 68.19 TO -54.89	14.00L&R	STIFFENER	1.25	2.50	5			
PYLON MOUNT	129.55 -151.32	FROM 66.25 TO -65.92	12.37L&R	BOX FITTING	NO DAMAGE ALLOWED					
LIFT LINK BEAM	136.13 -138.93	FROM 54.89 TO -40.41	3.78 -8.75	WEB				3.70 5		
	136.13 -138.73	54.89	14.00L&R	CAPS, UPPER WITH DOUBLER	0.75	1.50	5			
	136.13 138.73	FROM 54.89 TO -40.41	14.00L&R	CAPS, UPPER, WITHOUT DOUBLER	0.75	1.50	5	3.70 5		
	136.18 138.74	FROM 54.89 TO -40.41	8.55L&R	STIFFENERS	0.70	1.40	5			
	136.18 138.73	FROM 54.89 TO -40.41	14.00L&R	WEB & DOUBLER				1.75 5		
	136.18 138.73	40.41	14.00L&R	LOWER CAP WITH CARGO SLING	1.20	2.40	5			

Table 4-8. Damage Limits Fuselage, Midsection (FS 129 to 178) - Condition II (Cont)

COMPONENT/ MEMBER	LOCATION			ELEMENT	MAX DAMAGE LIMITS ALLOWED					FIGURE 4-1 AND NOTES
	BS	WL	BL		CAP/FLANGE			SKIN/WEB		
					CD'	CL'	N	WL'	N	
LIFT LINK BEAM	136.18 -138.73	40.41	14.00L&R	LOWER CAP COVER	(D'=NxCL)			(D'=NxWL)		
	136.18 -138.73	FROM 54.89 TO -40.41	14.00L&R	END SUPPORTS ZEE SECTION	2.00	4.00	5			
	137.56	55.30	0.00	LIFT LINK & ATTACHMENT	NO DAMAGE ALLOWED					
	137.56	39.00	0.00	CARGO SLING FITTING	NO DAMAGE ALLOWED IF FITTING IS USED FOR CARGO					
5TH MOUNT	153.45	FROM 67.50 TO -63.87	14.00L&R	FITTING	NO DAMAGE ALLOWED					
CLIP	178.00	22.00	14.00L&R	TENSION TIE	NO DAMAGE TO CLIPS					
FITTING	129.00	FROM 26.00 TO -14.00	14.00L&R	SPLICE	0.90	1.80	5			
FITTING, EXTERNAL STORES	155.00	11.00	35.54L&R	LOWER FITTING	NO DAMAGE ALLOWED IF FITTING IS USED FOR EXTERNAL STORES					
	129.00	9.60	36.97L&R	LOWER FITTING						
	129.00 155.00	20.24	45.95L&R	UPPER FITTINGS						
LANDING GEAR	163.00	12.00	14.00L&R	AFT FITTING	NO DAMAGE ALLOWED					

Table 4-9. Damage Limits Fuselage, Aft (FS 178 to 243) - Condition II

COMPONENT/ MEMBER	LOCATION			ELEMENT	MAX DAMAGE LIMITS ALLOWED					FIGURE 4-1 AND NOTES
	BS	WL	BL		CAP/FLANGE			SKIN/WEB		
					CD'	CL'	N	WL'	N	
AFT FUSELAGE	178.00 -211.06		c - L&R OUTBD	SKIN	(D' = NxCL)			(D' = NxWL)		
	211.06 -243.89		c - L&R OUTBD	SKIN				3.25	5	
	178.00 202.00		14.00L&R	ACCESS DOOR				7.00	5	NO DAMAGE WITHIN 1.5 INCH OF EDGE
DECKS	178.00 239.00	54.89	14.00L&R	HONEYCOMB PANEL				8.00	5	
	200.00	54.89	c SHIP	ENGINE MOUNT ATTACHMENT	NO DAMAGE ALLOWED					
	214.00	54.89	9.70	ANTI-TORQUE SUPPORT						
	178.00 239.00	54.89	14.00L&R	EDGE, HONEYCOMB PANEL	1.5	6.00	5			
MAIN BEAMS	192.00	22.00	14.00L&R	BEAM CAP	.45	.90	5			
	178.00	22.00	14.00L&R	CONTOUR BEAM CAP	.20	.40	5			
	211.06	54.89	14.00L&R	BEAM CAP	.7	1.4	5			
	211.06 243.89	22.00	14.00L&R	LOWER CAP	.15	.3	5			

Table 4-9. Damage Limits Fuselage, Aft (FS 178 to 243) - Condition II (Cont)

COMPONENT/ MEMBER	LOCATION			ELEMENT	MAX DAMAGE LIMITS ALLOWED					FIGURE 4-1 AND NOTES
	BS	WL	BL		CAP/FLANGE			SKIN/WEB		
					CD'	CL'	N	WL'	N	
MAIN BEAMS	178.00			LOWER CAP	(D'=NxCL)			(D'=NxWL)		
	211.06	22.00	14.00L&R		.15	.3	5			
	178.00	22.00 TO LOWER CONTOUR		WEB				2.25	5	
	211.06		14.00L&R	OUTBOARD ANGLE	.40	.80	5			
	214.23 241.20	FROM 54.89 TO 22.00		TENSION ROD	NO DAMAGE ALLOWED					
	211.06 243.89	FROM 54.89 TO 22.00		WEB						
	211.06 243.89	FROM 54.89 TO 22.00		STIFFENER						
BULKHEADS	178.00	FROM 22.00 TO 12.40	^c -14.00L&R	LOWER WEB						
	178.00	22.00	14.00L&R	HORIZONTAL STIFFENER	.4	.75	5			
	211.06	FROM 54.89 TO 19.40	14.00L&R	STIFFENER	NO DAMAGE ALLOWED					
	211.06	FROM 27.30 TO 19.40	9.70L 4.80R	OIL COOLER SUPPORT						
	211.06	FROM 36.72 TO 29.84	6.30 14.00	ANTI-TORQUE BOOST CYL SUPPORT						

Table 4-9. Damage Limits Fuselage, Aft (FS 178 to 243) - Condition II (Cont)

COMPONENT / MEMBER	LOCATION			ELEMENT	MAX DAMAGE LIMITS ALLOWED				FIGURE 4-1 AND NOTES
	BS	WL	BL		CAP/FLANGE		SKIN/WEB		
					CD' (D'=NxCL)	CL' N	WL' (D'=NxWL)	N	
BULKHEADS	211.06	36.72		SKIN & EDGE DOUBLER	NO DAMAGE ALLOWED				
	243.85			BOLT HOLE FITTINGS					
TAIL BOOM ATTACHMENT	243.85	59.78	11.39	UPPER R/H FITTINGS					
	211.06	54.86	14.00	CAP SPLICE FITTINGS					
JACKING FITTING	211.06		14.00L&R	FITTINGS	DO NOT JACK IF DAMAGED AREA WILL NOT SUPPORT HELICOPTER				
TIEDOWN	211.06		14.00L&R	FITTINGS	DO NOT USE IF DAMAGED				
AFT ENGINE	200.00	54.89	14.00	FITTINGS	NO DAMAGE ALLOWED				
	178.00	54.89	14.00	SUPPORT					

Table 4-10. Damage Limits Tail Boom - Condition II

COMPONENT/ MEMBER	LOCATION			ELEMENT	MAX DAMAGE LIMITS ALLOWED					FIGURE 4-1 AND NOTES
	BS	WL	BL		CAP/FLANGE			SKIN/WEB		
					CD'	CL'	N	WL'	N	
TAIL BOOM	17.37			UPPER RIGHT ANGLE	(D' = NxCL)			(D' = NxWL)		SEE FIGURE
	-194.30				.90	1.80	5			
	17.37			UPPER RIGHT LONGERON	3.34	6.68	10			
	17.37			UPPER RIGHT STRINGER	.95	1.9	5			
	17.37			LOWER RIGHT STRINGER	.78	1.56	5			
	17.37			LOWER RIGHT LONGERON	3.50	7.00	10			
	17.37			BOTTOM MIDDLE STRINGER	1.15	2.30	5			
	17.37			LOWER LEFT LONGERON	NO DAMAGE ALLOWED					
	59.05			LOWER LEFT LONGERON	3.80	7.60	10			
	17.37			LOWER LEFT STRINGER	.95	1.90	5			
	17.37			UPPER LEFT STRINGER	1.35	2.70	5			
	17.37			UPPER LEFT LONGERON	3.5	7.0	10			

Table 4-10. Damage Limits Tail Boom - Condition II (Cont)

COMPONENT/ MEMBER	LOCATION			ELEMENT	MAX DAMAGE LIMITS ALLOWED					FIGURE 4-1 AND NOTES
	BS	WL	BL		CAP/FLANGE			SKIN/WEB		
					CD'	CL'	N	WL'	N	
TAIL BOOM	17.37			UPPER LEFT ANGLE	(D'=NxCL)			(D'=NxWL)		
	-194.30				.72	1.44	5			
	17.37			TOP RIGHT STRINGER	1.13	2.26	5			SEE FIGURE
	-38.43									
	17.37			MIDDLE UPPER RIGHT STRINGER	.90	1.80	5			
	-38.43									
	17.37			MIDDLE RIGHT STRINGER	.96	1.92	5			
	-38.43									
	17.37			MIDDLE LOWER RIGHT STRINGER	1.00	2.00	5			
	-38.43									
	17.37			LOWER RIGHT ANGLE	1.10	2.20	5			
	-38.43									
	17.37			BOTTOM RIGHT STRINGER	1.12	2.24	5			
	-38.43									
	80.44			BOTTOM RIGHT ANGLE	1.20	2.40	5			
	-101.38									
	17.37			BOTTOM LEFT INBOARD ANGLE	1.20	2.20	5			
	-38.43									
	80.44			BOTTOM LEFT INBOARD ANGLE	1.30	2.60	5			
	-101.38									
	17.37			BOTTOM LEFT OUTBOARD ANGLE	1.20	2.40	5			
	-38.43									

Table 4-10. Damage Limits Tail Boom - Condition II (Cont)

COMPONENT/ MEMBER	LOCATION			ELEMENT	MAX DAMAGE LIMITS ALLOWED					FIGURE 4-1 AND NOTES
	BS	WL	BL		CAP/FLANGE			SKIN/WEB		
					CD'	CL'	N	WL'	N	
					(D' = NxCL)			(D' = NxWL)		
TAIL BOOM	80.44 -101.38			BOTTOM LEFT OUTBOARD ANGLE	1.30	2.60	5			
	38.43 -59.50			BOTTOM LEFT IN- BOARD STRINGER	1.50	3.00	5			SEE FIGURE
	101.38 -122.33			BOTTOM LEFT IN- BOARD STRINGER	1.20	2.40	5			
	17.38 -59.50			BOTTOM LEFT OUT- BOARD STRINGER	1.30	2.60	5			
	101.38 -122.33			BOTTOM LEFT OUT- BOARD STRINGER	1.30	2.60	5			
	17.37 -38.43			MIDDLE LOWER LEFT STRINGER	1.30	2.60	5			
	17.37 -38.43			MIDDLE LEFT STRINGER	1.20	2.40	5			
	17.37 -38.43			MIDDLE UPPER LEFT STRINGER	1.80	3.60	5			
	17.37 -38.43			TOP LEFT STRINGER	2.50	5.00	5			
BULKHEAD	17.37			OUTER FLANGE	.98	1.96	5			
				INNER FLANGE	.55	1.1	5			

Table 4-10. Damage Limits Tail Boom - Condition II (Cont)

COMPONENT/ MEMBER	LOCATION			ELEMENT	MAX DAMAGE LIMITS ALLOWED					FIGURE 4-1 AND NOTES
	BS	WL	BL		CAP/FLANGE			SKIN/WEB		
					CD'	CL'	N	WL'	N	
BULKHEAD				WEB	(D' = NxCL)			(D' = NxWL)		
								.40	10	
	38.43			OUTER FLANGE	1.00	2.00	5			
				INNER FLANGE	.60	1.20	5			
				WEB				.50	10	
	59.50			OUTER FLANGE	1.10	2.20	5			
				INNER FLANGE	.60	1.20	5			
				WEB				.64	10	
	80.44			OUTER FLANGE	1.16	2.32	5			
				INNER FLANGE	.65	1.30	5			
				WEB				.75	10	
	101.33			OUTER FLANGE	1.2	2.4	5			

Table 4-10. Damage Limits Tail Boom - Condition II (Cont)

COMPONENT/ MEMBER	LOCATION			ELEMENT	MAX DAMAGE LIMITS ALLOWED					FIGURE 4-1 AND NOTES
	BS	WL	BL		CAP/FLANGE			SKIN/WEB		
					CD'	CL'	N	WL'	N	
					(D' = NxCL)			(D' = NxWL)		
BULKHEAD	101.33			INNER FLANGE	.68	1.36	5	.40	10	
				WEB				.88	10	
	122.33			OUTER FLANGE	1.30	2.60	5			
				INNER FLANGE	.70	1.40	5			
				WEB				1.00	10	
	143.28			OUTER FLANGE	1.30	2.60	5			
				INNER FLANGE	.75	1.50	5			
				WEB				1.12	10	
	164.23			OUTER FLANGE	1.50	3.00	5			
				INNER FLANGE	1.00	2.00	5			
				WEB				1.2	10	

Table 4-10. Damage Limits Tail Boom - Condition II (Cont)

COMPONENT/ MEMBER	LOCATION			ELEMENT	MAX DAMAGE LIMITS ALLOWED					FIGURE 4-1 AND NOTES
	BS	WL	BL		CAP/FLANGE			SKIN/WEB		
					CD'	CL'	N	WL'	N	
BULKHEAD	185.18			OUTER FLANGE	1.75	3.50	5	.40	10	
				INNER FLANGE	1.20	2.60	5	.88	10	
				WEB				1.2	10	
	194.30			OUTER FLANGE	2.00	4.00	5			
				INNER FLANGE	1.40	2.80	5			
				WEB				1.20	10	
VERTICAL FIN	5.08 -99.05			FORWARD SPAR	1.10	2.20	5			
	5.08 -59.05			AFT SPAR	4.40	8.80	5			
	10.03 -59.05			STRINGER	UP TO TWO MAN-ADJACENT RIBS MAY BE SEVERED, & 50% X-SECTION CRACKED AT OTHER LOCATIONS ALONG STRINGER					
	BETWEEN FORWARD & AFT SPARS			SKIN				3.3	1.5	
	AFT SPAR TO TRAILING EDGE			SKIN				6.6	1.5	

Table 4-10. Damage Limits Tail Boom - Condition II (Cont)

COMPONENT/ MEMBER	LOCATION			ELEMENT	MAX DAMAGE LIMITS ALLOWED				FIGURE 4-1 AND NOTES	
	FS	WL	BL		CAP/FLANGE			SKIN/WEB		
					CD'	CL'	N	WL'		N
VERTICAL FIN	5.08			TAIL ROTOR DRIVESHAFT COVER	(D' = NxCL) (D' = NxWL)				NO LIMIT ON DAMAGE TO ELEMENT	
	-59.05									
	AFT OF BS 194.03			SKIN				3.3 1.5		
	BETWEEN FORWARD AND AFT SPARS			RIBS	ONE RIB MAY BE SEVERED, ADDITIONALLY ANY RIB MAY HAVE UP TO 50% X-SECTION CRACKED					
	AFT SPAR TO TRAILING EDGE			RIBS	UP TO TWO RIBS MAY BE SEVERED, ADDITIONALLY, UP TO 50% X-SECTION MAY BE CRACKED ON ANY OF THE RIBS					
	BS 227.00			BULKHEAD	1.00	2.00	5			
	BS 194.30 -227.00			ANGLE	.90	1.80	5			
	BS 194.30 -227.00			STRINGERS, CHANNELS	.50	1.00	5			
				42° GEARBOX MOUNT	NO DAMAGE ALLOWED					
				90° GEARBOX MOUNT						
				TRAILING EDGE	NO LIMIT ON DAMAGE TO ELEMENT					
				42° GEARBOX COVER						

Table 4-10. Damage Limits Tail Boom - Condition II (Cont)

COMPONENT/ MEMBER	LOCATION			ELEMENT	MAX DAMAGE LIMITS ALLOWED				FIGURE 4-1 AND NOTES					
	FS	WL	BL		CAP/FLANGE			SKIN/WEB						
					CD'	CL'	N	WL'		N				
VERTICAL FIN	194.30 -FWD SPUR			UPPER LEFT LONGERON	(D' = NxCL)			(D' = NxWL)						
					3.50	7.00	10							
					194.30 -FWD SPUR			LOWER LEFT LONGERON	4.00		8.00	10		
									194.30 -FWD SPUR				UPPER RIGHT LONGERON	4.25
194.30 -FWD SPUR			LOWER RIGHT LONGERON	4.00	8.00	10								

Section III. NOSE SECTION

4-4. GENERAL.

a. This section applies to the primary structure and external skin of the helicopter's nose section from fuselage station (FS) 7.50 to 23.00 inches. No part of the nose section is a critical load carrying primary structural, and therefore, most repairs to extensive battle damage will be deferred. The repair actions listed in this section are only intended for safety of the crew and to prevent further damage to helicopter.

b. The nose section houses the cockpit instrument panel, battery compartment, radio receiver/transmitter, and other instruments. Any damage to this equipment will be covered in other chapters.

c. The former bulkhead at FS 23.00 also serves as attachment area for the tail rotor control (foot pedals) support bracket.

4-5. **NOSE SECTION, DAMAGE TO EXTERNAL STRUCTURES OR SKIN.** External damage to skins and nose doors is all secondary structure and can be deferred and repaired later per TM 55-1500-204-25/1 or TM 55-1520-210-23. Loose skin or external structure which can cause serious problems in flight will be removed by the following procedures.

LIMITATIONS: Reduced flight velocity may be required.

PERSONNEL/TIME REQUIRED:

- 1 Soldier
- 15 Minutes

MATERIALS/TOOLS REQUIRED:

- Cleaning Solvent (item 76, App C)
- Adhesive Tape (items 153, 156, App C)

PROCEDURAL STEPS:

1. Inspect damage area and determine if it could cause such problems as the following:

a. External skin blowing off and causing injury to the pilot, crew members, or being injected into engine air intake.

b. Affecting the aerodynamics of flight.

c. Reduce or restrict any of the pilots functions such as visibility.

2. Remove any loose skin, doors, window, or panels as is necessary to continue flight or mission.

3. If time permits, perform the following steps.

a. Stop drill all cracks or trim out cracks when removing damaged skin.

b. Clean area with naphtha and apply any aluminum backed pressure sensitive adhesive tape to bridge and cover the hole damage area.

NOTE

- Some solvents will dissolve plexi-glass. Use naphtha or clean with a detergent and water to remove grease and dirt.

• Naphtha is highly flammable. Use only in well-ventilated areas. Avoid inhalation of vapor and skin contact. Do not use near open flame or in areas where very high temperatures prevail.

4. Record BDAR action taken. When mission is complete, as soon as practical, repair the equipment/system using standard maintenance procedures.

4-6. NOSE SECTION, BOTTOM WINDOW CRACKS AND HOLES. External damage to window plexiglass is secondary structure and can be deferred and repaired later per TM 55-1500-204-25/1 or TM 55-1520-210-23. Loose window plexiglass which can cause serious problems in flight will be removed and area repaired by the following procedures.

LIMITATIONS: Reduced flight velocity may be required.

PERSONNEL/TIME REQUIRED:

- 1 Soldier
- 1 Hour

MATERIALS/TOOLS REQUIRED:

- Cleaning Solvent (item 76, App C)
- Adhesive Tape (items 153, 156, App C)
- Adhesive, 30 Minute Epoxy (item 3, App C)
- Cloth, Fiberglass (item 63, App C)

PROCEDURAL STEPS:

1. If damage is in the form of cracks, repair as follows:
 - a. Stop drill cracks and clean the area with naphtha (item 76, App C).

- b. Apply adhesive tape to both sides of the cracked window.

2. For hole damage, repair as follows:
 - a. Cut out and trim to remove cracks. Clean the area with naphtha.

- b. Bridge the hole by overlapping with strips of 2 inch wide tape. Tape one side first and then the other.

- c. Cover the outside tape with a thin layer of 30 minute epoxy, brushing adhesive 2 inches onto the undamaged plexiglass window all the way around the patch.

- d. While epoxy is still uncured or wet, cover the area with fiberglass cloth patch. Brush the patch from center to edges to remove air and smoothen the patch.

- e. Wait 30 minutes for epoxy patch to dry. The size of hole to be repaired is only limited by the time and materials available.

3. Record BDAR action taken. When mission is complete, as soon as practical, repair the equipment/system using standard maintenance procedures.

CHAPTER 5
ALIGHTING GEAR

**BDAR FIXES SHALL BE USED ONLY IN COMBAT OR FOR TRAINING
AT THE DISCRETION OF THE COMMANDER.
(AUTHORIZED TRAINING FIXES ARE LISTED IN APPENDIX E.)
IN EITHER CASE, DAMAGES SHALL BE REPAIRED BY STANDARD
PROCEDURES AS SOON AS PRACTICABLE.**

Section I. INTRODUCTION

5-1. SCOPE.

a. The alighting gear assembly consists of two skid tubes (1, Figure 5-1) attached to ends of two arched cross-tubes (2 & 3). These in turn are attached to the fuselage. This gear supports the UH-1 helicopter's weight of approximately 9500 pounds upon landing.

b. The alighting gear will normally sustain two types of battle damage. Impact damage by foreign objects, projectiles, or other pieces of aircraft debris, and the deforming of alighting gear by hard landings. Battle damage to the gear assembly could weaken or deform the structure. In turn, this weakened alighting gear assembly could result in collapsed gear and main rotor blade strike to the ground. Similarly, a deformed alighting gear could cause the helicopter to alight at an abnormal angle and cause a rotor blade ground strike.

c. Battlefield damage to the alighting gear sustained in flight could result in an abnormal landing procedure.

Therefore, an in-flight or low hover assessment will be required to determine if a normal landing procedure will be necessary. Emergency landing procedures are covered in TM 55-1520-210-10.

d. The purpose of this chapter is to provide BDAR temporary fixes which are not authorized or listed in other maintenance manuals. The BDAR fixes will allow a temporary fix which will return the aircraft to a flight status to complete the assigned mission and/or to self-recover.

e. Fixes by this BDAR may require jacking up of helicopter per TM 55-1520-210-23, or any other equivalent means.

5-2. ASSESSMENT PROCEDURES. Refer to Table 5-1.

5-3. REPAIR PROCEDURE INDEX.

PARA.

Skid Tubes 5-4

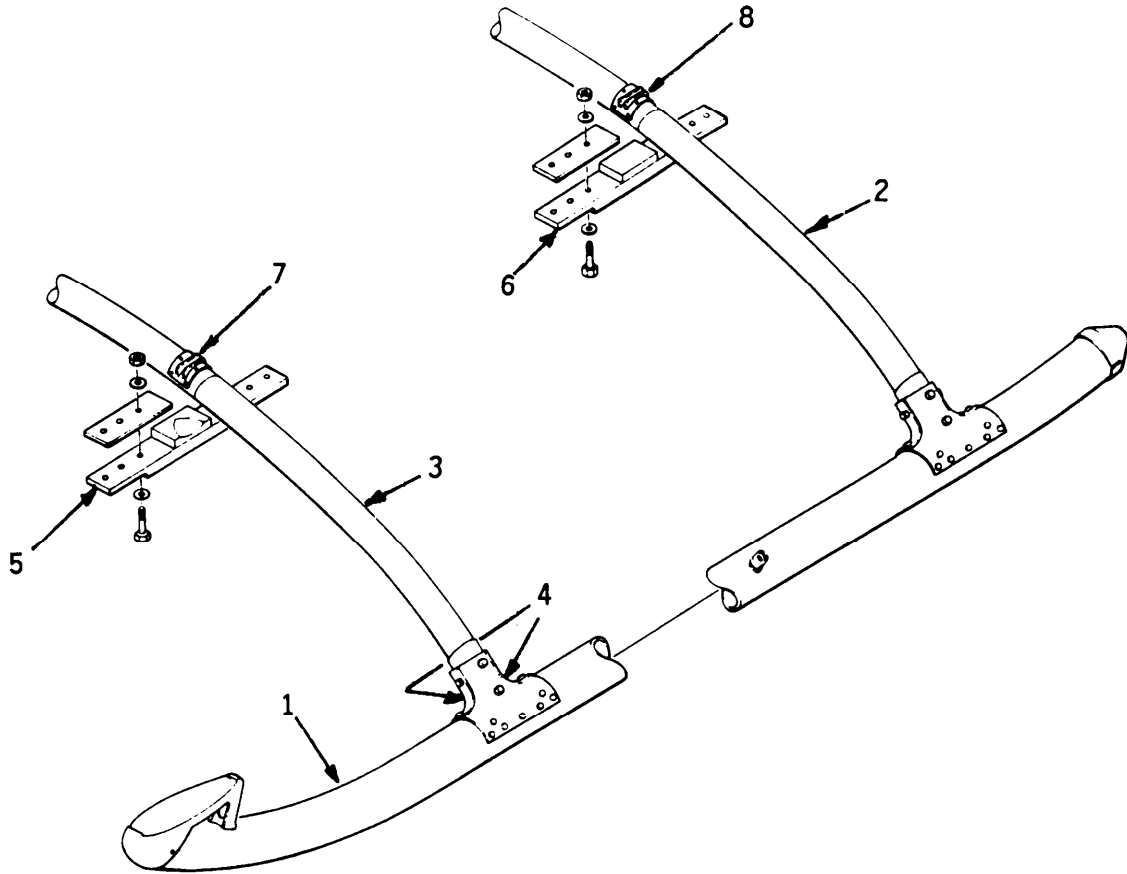

1. Skid Tube Assy
2. Aft Crosstube Assy
3. Forward Crosstube Assy
4. Skid Saddle Assy
5. Structural Support (Cap)
6. Structural Support (Cap)
7. Landing Gear Support
8. Landing Gear Support

Figure 5-1. Landing Gear and Support Installation

Table 5-1. Assessment Procedures

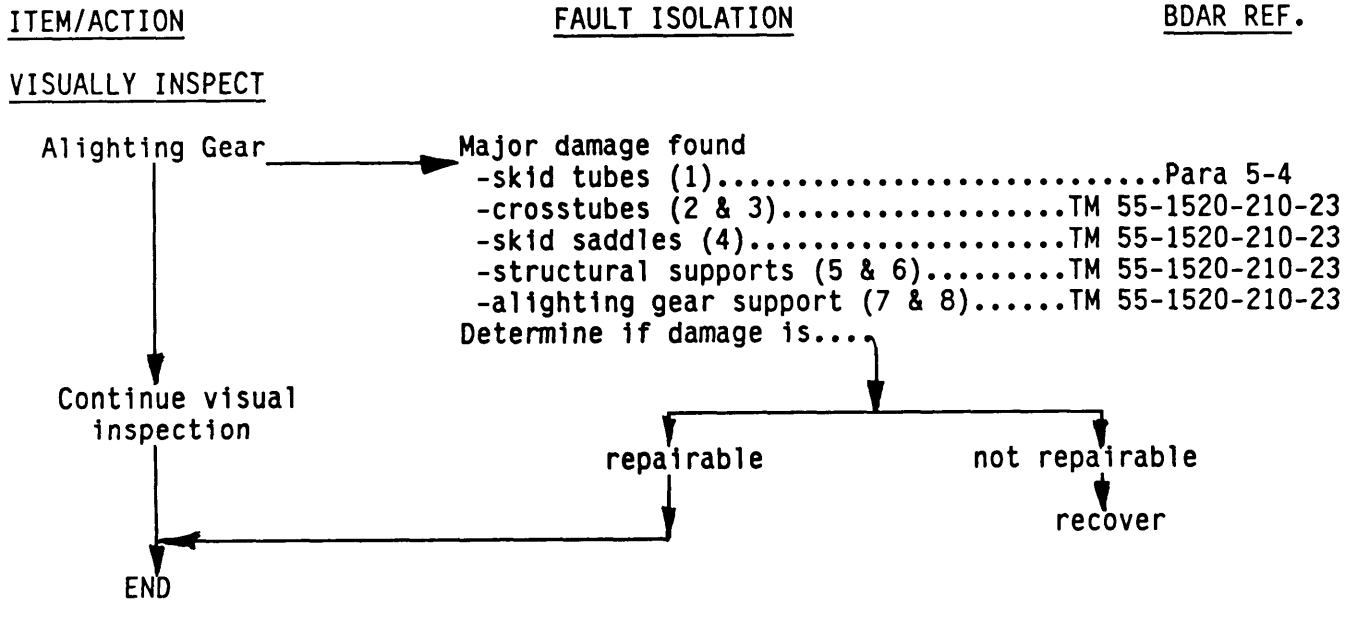

Section II. SKID TUBE

5-4. GENERAL. The skid tubes can suffer damage by either impact of projectiles, explosions, or by hard landings. Damage to the ends of the skid tubes is not critical and can be deferred. However, bent skid tubes which will interfere with normal landing procedures can be remedied by removing the ends that are bent. This fix only applies to the ends of the skid tubes past the crosstubes and not the center joining section.

5-5. SKID TUBES, DAMAGE TO AREA A AND E OF FIGURE 5-2.

LIMITATIONS: No run on landings permitted. All landings shall be from a low hover with no forward speed as specified in emergency landing procedures in TM 55-1520-210-10.

PERSONNEL/TIME REQUIRED:

- 1 Soldier
- 30 Minutes

MATERIALS/TOOLS REQUIRED:

- Hacksaw (item 94, Sec II, App B) with 18 to 24 Tooth High Speed Steel Blade

PROCEDURAL STEPS:

1. Deferrable damage to A and E of Figure 5-2 may include up to complete rupture and loss of section A and E in both skids.
2. Severely deformed (bent) skid tubes in area A and E, which will interfere with normal landing, will be fixed by removing the section with a hacksaw. Cut the skid tube right next to the skid saddle, but do not cut the saddle.
3. Record BDAR action taken. When mission is complete, as soon as practical, repair the equipment/system using standard maintenance procedures.

TM 55-1520-210-BD
ALIGNING GEAR

5-6. SKID TUBES, DAMAGE TO AREA C AND D OF FIGURE 5-2.

LIMITATIONS: No run on landings permitted. All landings shall be from a low hover with no forward speed as specified in emergency landing procedures in TM 55-1520-210-10. This repair is limited and will only be applied when one skid tube is still fully functional and has no major damage.

PERSONNEL/TIME REQUIRED:

- 2 Soldiers
- 30 Minutes

MATERIALS/TOOLS REQUIRED:

- Angle Extrusion (item 53, App C)
- Cherrymax Rivets 3/16 inch (CR 3213-6-7) (item 112, App C)

PROCEDURAL STEPS:

1. See Figure 5-3 for splint repair of skid tubes.
2. The following repair is to be used to repair one skid tube. The other skid tube must be functional. Any damage which affects 1/2 of the cross section of the skid tube and up to a complete separation of area C or D can be expediently repaired by applying a temporary splint.
3. Cut an aluminum or steel angle extrusion to bridge the damaged area of the skid tube. The splint piece length should extend onto 14 inches of undamaged skid tube on both sides of damage. Remove any damaged part of skid tube. Trim rough edges which will interfere with the fitting of splint.
4. With splint clamped in place, drill holes for 3/16 diameter blind rivets. See Figure 5-3. Rivet hole pattern will be a straight line of rivets on the side and on the bottom of angle extrusion with rivet spacing at 9/16 inch (3 rivet

diameters). Install a minimum of 88 blind rivets per splint. A second splint may be installed on top, opposite first splint, if needed.

5. Record BDAR action taken. When mission is complete, as soon as practical, repair the equipment/system using standard maintenance procedures.

5-7. SKID TUBES, DAMAGE TO AREA B OF FIGURE 5-2.

LIMITATIONS: No run on landings permitted. All landings shall be from a slow hover with no forward speed as specified in emergency landing procedures in TM 55-1520-210-10. This repair is limited to skid tube damage. It is not to be used for repairs of the skid tube saddle (4, Figure 5-1).

PERSONNEL/TIME REQUIRED:

- 1 Soldier
- 30 Minutes

MATERIALS/TOOLS REQUIRED:

- Hose Clamps (4 or more) (item 37, App C)
- Skid Tube Shoes or Steel Sheet 1025 (0.062 in thick) formed to fit

PROCEDURAL STEPS:

1. Deferrable damage in area B, Figure 5-2, may include up to 2.00 diameter (3.14 sq. in.) holes.
2. Damage between 2.0 diameter and 3.1 diameter holes may be repaired by this BDAR fix (see Fig 5-4 for this repair). Damage exceeding 3.1 diameter holes will require replacement of skid tube.
3. Use a piece of skid shoe approximately 24 inches long, or a piece of steel sheet metal to bridge the damage. cut the repair piece from a new or used skid shoe. The skid shoe off the damaged skid tube itself can be used for repair if time is available to remove it.

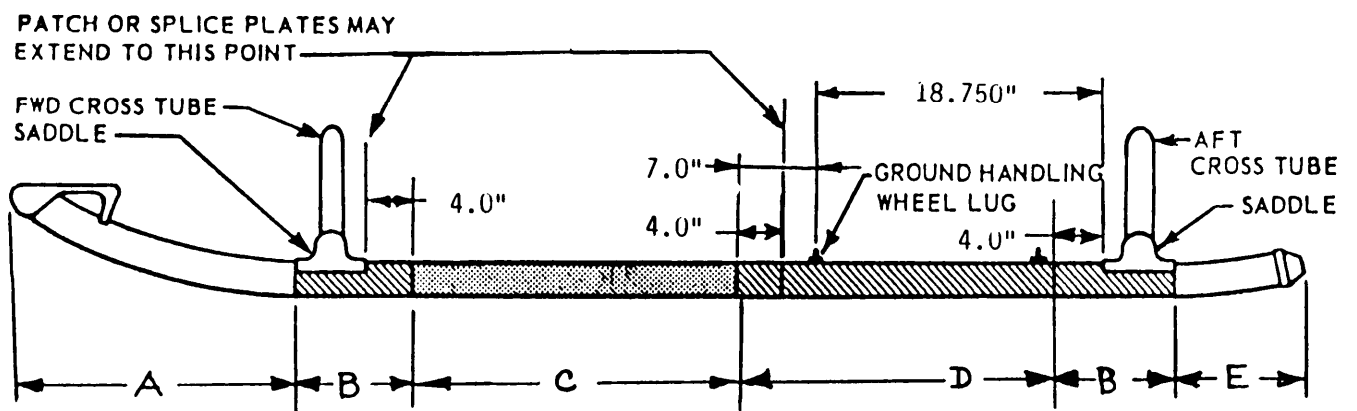

Figure 5-2. Skid Tube Damage Inspection

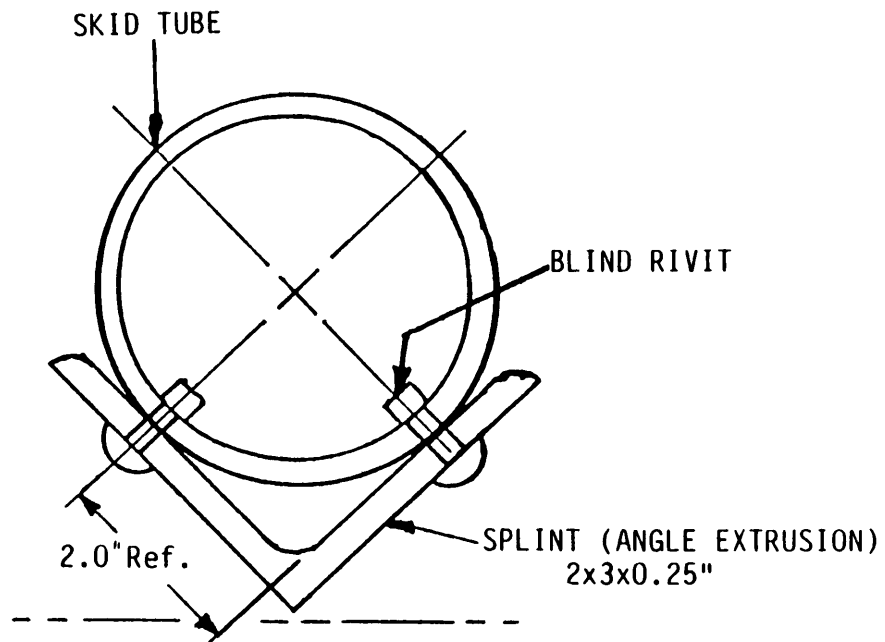

Figure 5-3. Skid Tube Splint Repair

4. Remove existing skid shoe from the damaged area only if it interferes with the splint repair piece. Remove burrs and sharp metal edges by cutting, filing, and hammering down edges.

5. Place a repair piece of skid shoe over the damage area. If available, place another piece of skid shoe on top of the skid tube right over the damage. Clamp the repair splint skid shoes in

place with a minimum of four hose clamps. If hose clamps are not available, manufacture some clamps as shown in Figure 5-4. Use sheet metal (item 133, App C).

6. Record BDAR action taken. When mission is complete, as soon as practical, repair the equipment/system using standard maintenance procedures.

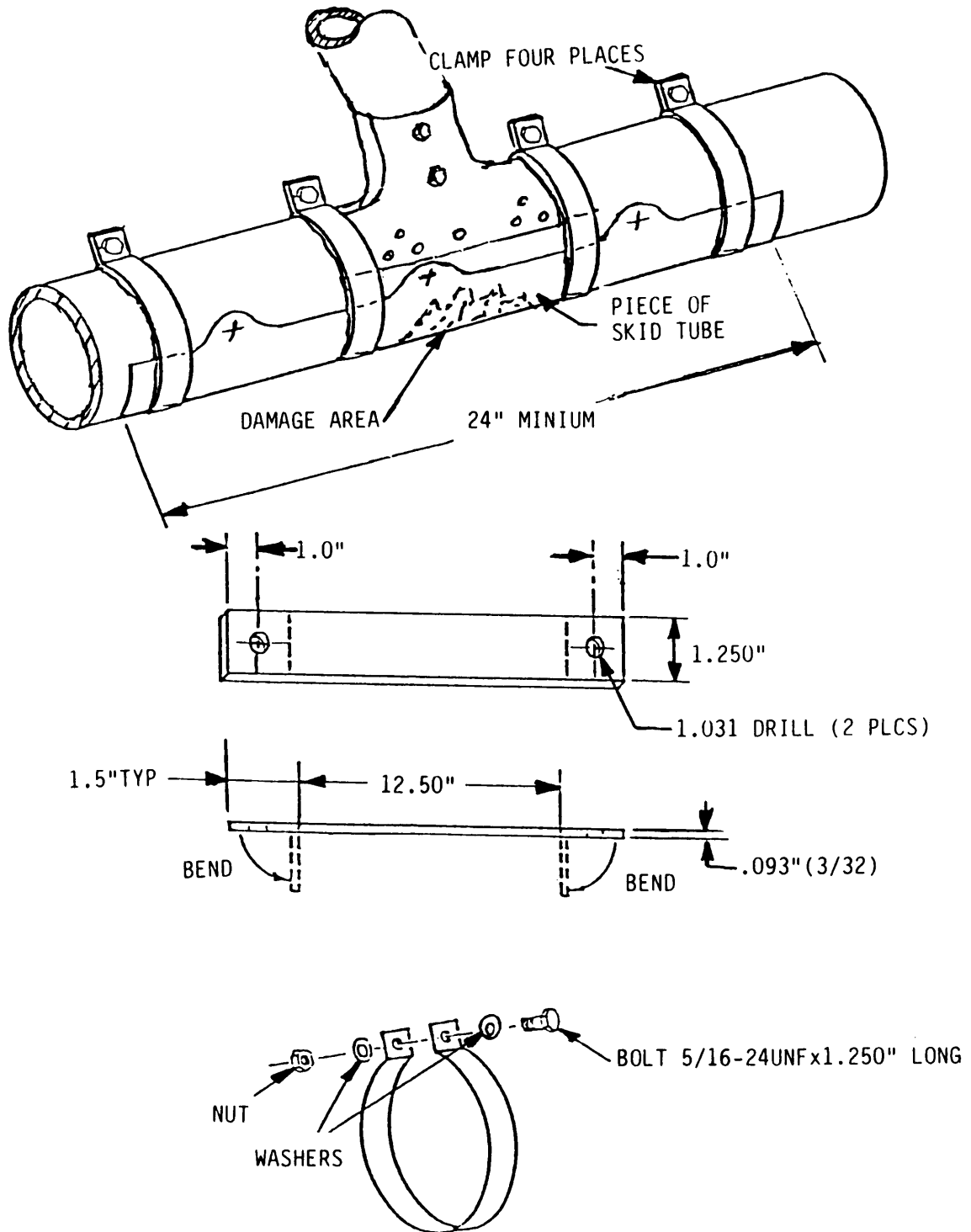

Figure 5-4. Skid Tube - Splint and Clamp Repair

CHAPTER 6
POWER PLANT INSTALLATION

**BDAR FIXES SHALL BE USED ONLY IN COMBAT OR FOR TRAINING
AT THE DISCRETION OF THE COMMANDER.
(AUTHORIZED TRAINING FIXES ARE LISTED IN APPENDIX E.)
IN EITHER CASE, DAMAGES SHALL BE REPAIRED BY STANDARD
PROCEDURES AS SOON AS PRACTICABLE.**

Section I. INTRODUCTION

6-1. SCOPE. This chapter will provide BDAR actions to the power plant and related systems such as fuel, oil, electrical, instruments, and engine control. Normally, any serious problem with these systems will first be indicated by the caution lights in the caution panel. This panel is located on the pedestal mount instrument panel in the helicopter's cockpit. Refer to TM 55-1520-210-10. These BDAR actions are provided for quick non-standard repair to the power plant system.

6-2. ASSESSMENT PROCEDURES. Refer to Table 6-1.

6-3 REPAIR PROCEDURE INDEX.

	<u>PARA.</u>
Oil Tank, Leaking.	6-5
Accessory Gearbox and Fuel Control Assy, Minor Leaks. . .	6-7

Section II. OIL TANK

6-4. GENERAL. The engine oil tank is located in the upper pylon fairing, Figure 6-1. The engine oil pressure gage in cockpit will indicate engine oil pressure, and the caution light in warning panel will light up when oil pressure drops below 25 psi. The oil sight glass next to the filler cap will indicate the oil level in the tank and indicate any oil lost or consumed by system. This section lists repair method to stop oil leaks through holes or cracks in the oil tank caused by battle damage. After a BDAR action, inspect the repaired area periodically, and closely monitor engine oil temperature, engine oil pressure and engine low pressure warning light.

6-5. OIL TANK, LEAKING.

GENERAL INFORMATION: Oil leaks may first be detected by pilot's observation of instrument in cockpit. Generally speaking, if the engine oil warning light comes on, an immediate landing will be required. After landing, visually inspect oil tank for leaks. From the oil tank's top sight glass marked "oil ferry level" down to "minimum oil level" mark in the bottom sight glass. The oil capacity between the two levels is approximately one gallon. This capacity is a safety reserve in case of emergency flight requirements. **If** the oil leaks are very minor, consideration should be given to deferring this BDAR until later.

Table 6-1. Assessment Procedures

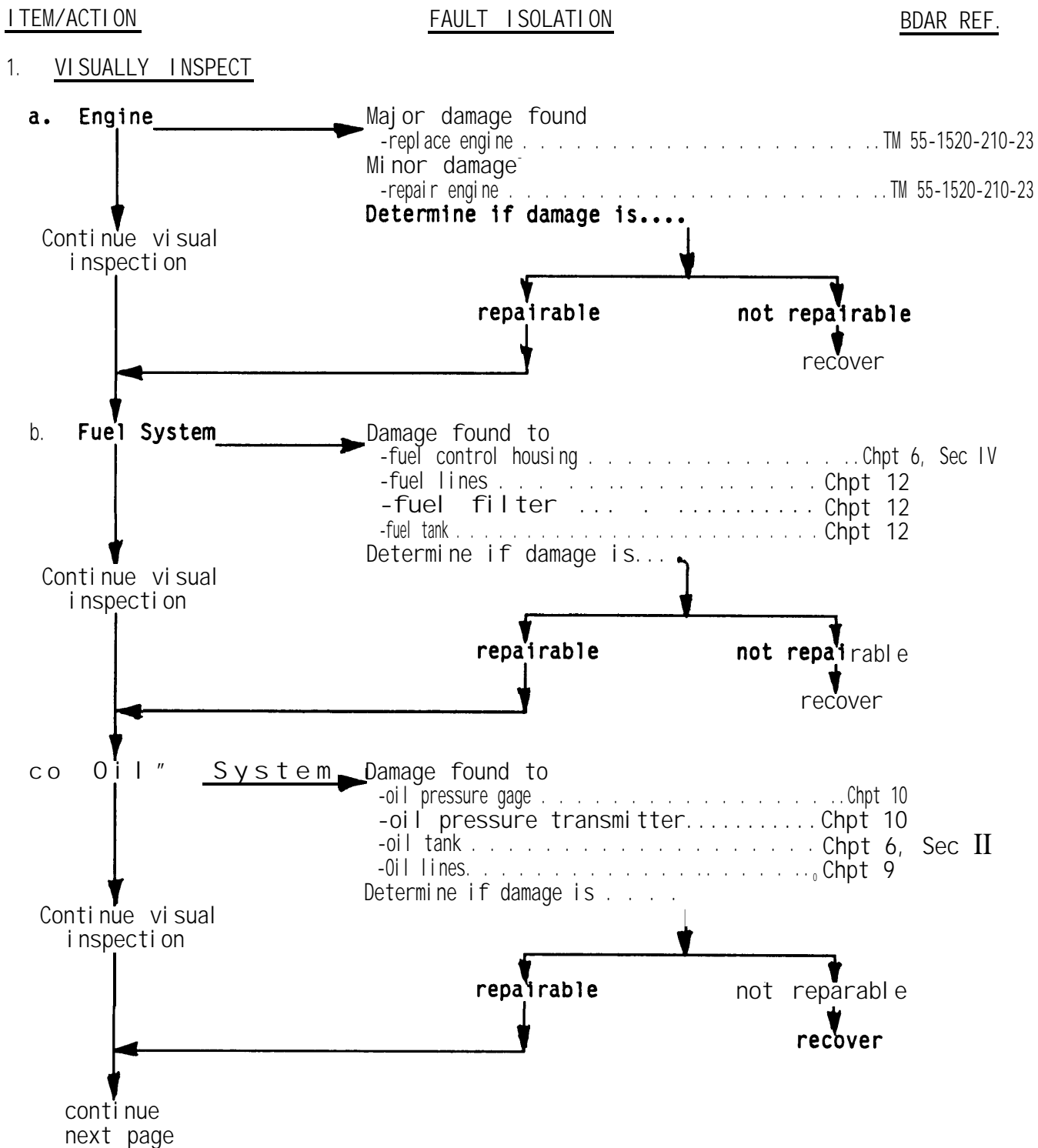

Table 6-1. Assessment Procedures (Cont)

<u>ITEM/ACTION</u>	<u>FAULT ISOLATION</u>	<u>BDAR REF.</u>
2. <u>PERFORMANCE/OPERATION TEST</u>		
Engine	Engine won't crank	
	-damaged/dead battery	Chpt 11
	-igniter/wiring	Chpt 11
	Engine won't start	
	-fuel filter clogged	Chpt 12
	-fuel control damaged	Chpt 12
End		

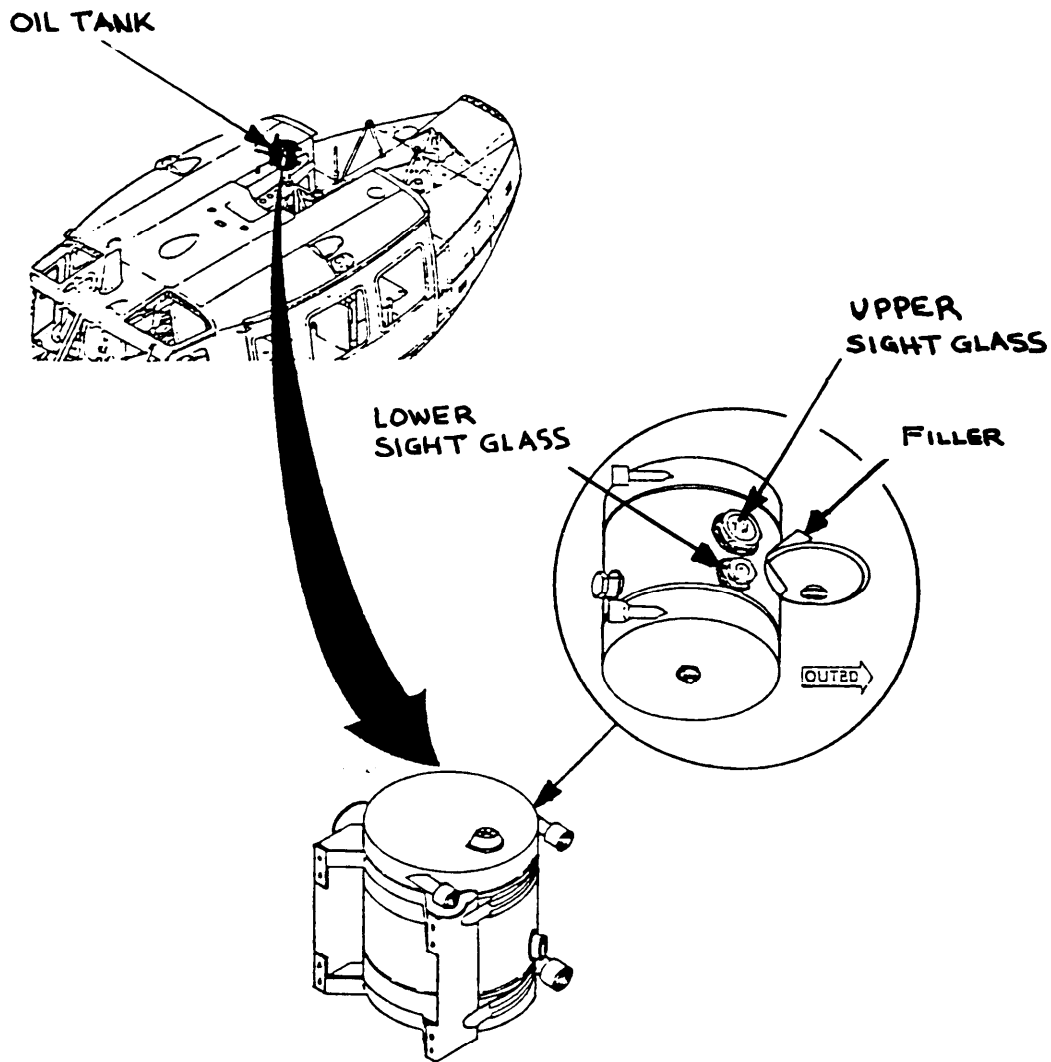

Figure 6-1. Oil Tank

OPTION 1: Screw, Washer, and Gasket for Small Holes, Figure 6-2

LIMITATIONS: Constant monitoring of engine oil pressure, oil temperature, and warning lights during the next flight.

PERSONNEL/TIME REQUIRED:

- 1 Soldier
- 20 Minutes

MATERIALS/TOOLS REQUIRED:

- Metal Washer to Fit Screw (item 175, App C)
- Rubber or Gasket (items 115-117, App C)
- Sheet Metal Screws (size to fit hole) (item 142 or 143, App C)

PROCEDURAL STEPS:

1. Cut a piece of gasket material that will overlap the hole by about 1 inch from the center of the hole.

2* Select a sheet metal screw that will screw in hole, and a washer to fit screw. Screw through the gasket material through the pierced hole and through the small hole in the oil tank to stop the oil leak.

3. Replenish oil supply.

4. Record BDAR action taken. When mission is complete, as soon as practical, repair the equipment/system using standard maintenance procedures.

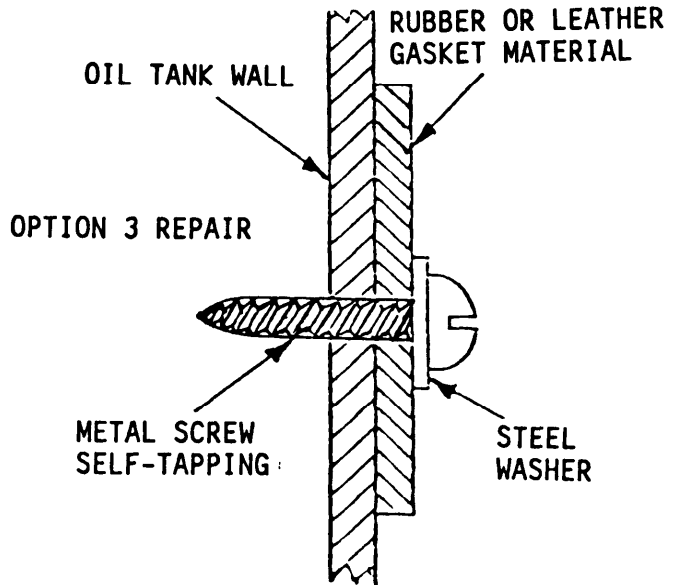

Figure 6-2. Screw, Washer and Gasket

OPTION 2: Riveted Sheet Metal Patch for Large Damage Holes, Figure 6-3.

LIMITATIONS: Constant monitoring of engine oil pressure, oil temperature, and warning lights during the next flight.

PERSONNEL/TIME REQUIRED:

- 2 Soldier
- 2 Hours

MATERIALS/TOOLS REQUIRED:

- Blind Rivets or Sheet Metal (items 142, 143, App C)
- Gasket Rubber (items 115-117, App C)
- Sheet Metal (items 129-141, App C)
- Solvent Cleaner (items 1, 76, 150, App C)
- 5-Minute Epoxy Sealant or Equivalent (item 4 or 5, App C)

PROCEDURAL STEPS:

1. Cut a piece of sheet metal that will overlap the hole by 1-1/2 inches all the

way around. Drill holes for the rivets or screws approximately 1 inch apart around the patch perimeter as shown in Figure 6-6. Use caution when drilling to keep metal shavings out of the oil tank.

20 **If** sealant is to be used, clean area around hole with solvent so sealant will adhere.

3. Put sealant or gasket material over hole. Put sheet metal plate over hole and secure with pop rivets or with self-tapping sheet metal screws.

4. If 5-minute epoxy sealant was used, let assembly cure for five minutes.

5. Replenish the oil supply.

6. Record BDAR action taken. When mission is complete, as soon as practical, repair the equipment/system using standard maintenance procedures.

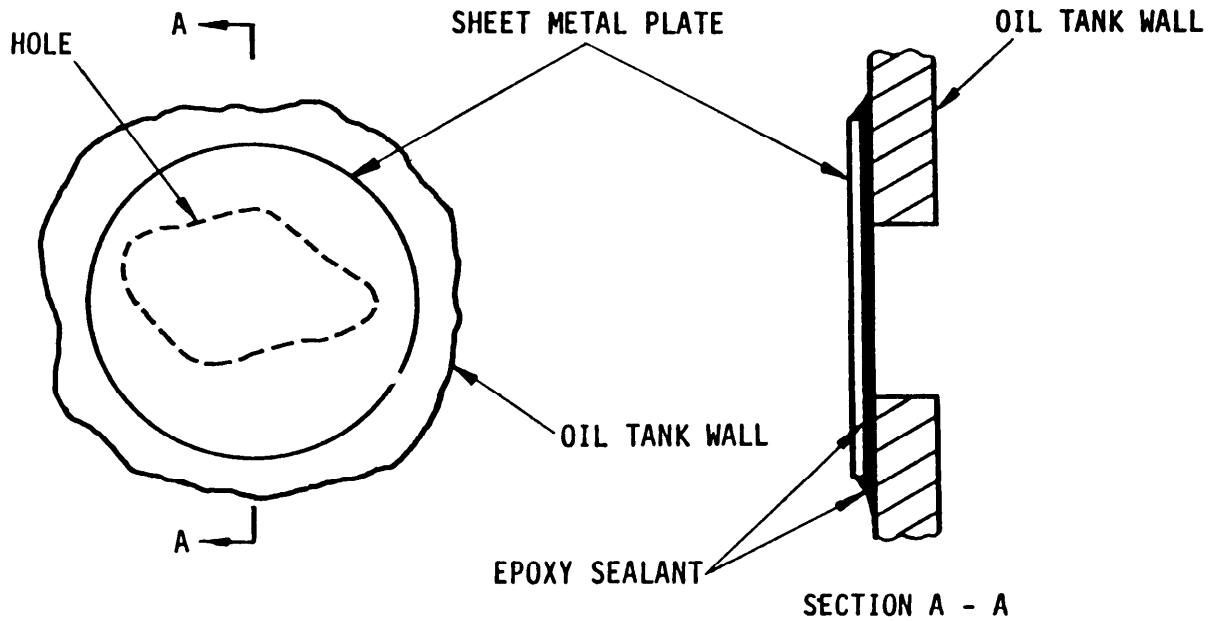

SHEET METAL PLATE WITH EPOXY

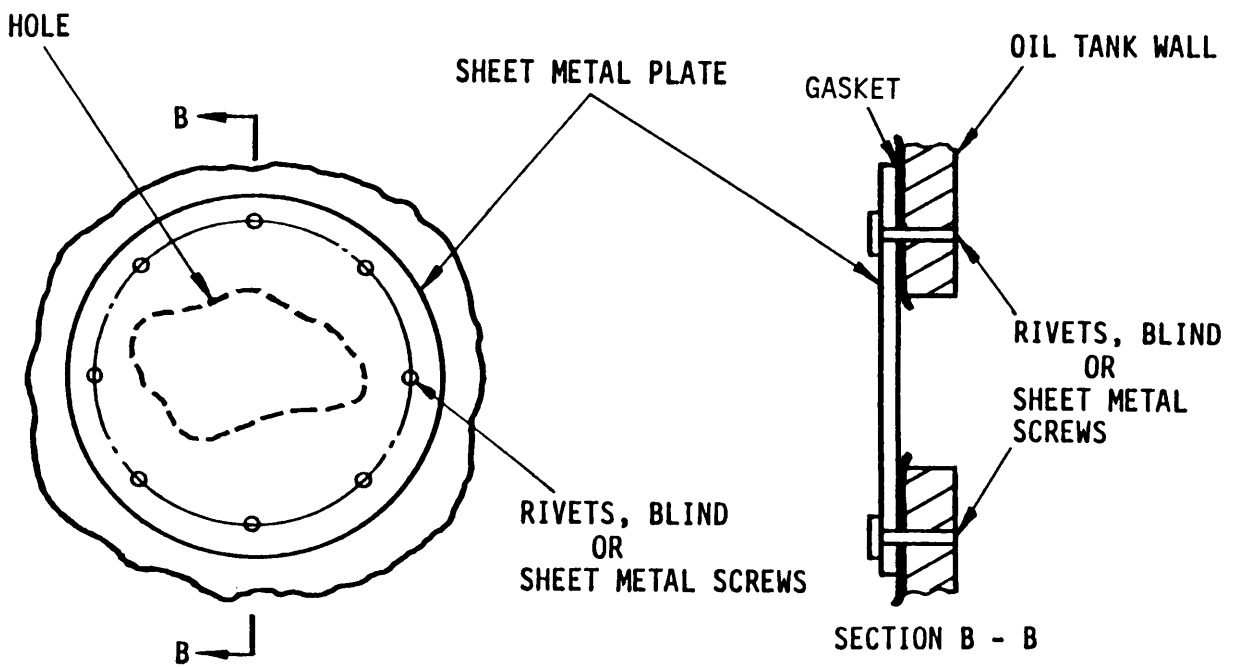

SHEET METAL PLATE WITH BLIND RIVETS

Figure 6-3. Sheet Metal with Sealant or Blind Rivets

Section III. ACCESSORY GEARBOX AND FUEL CONTROL ASSEMBLY

6-6. GENERAL.

a. The engine accessory gearbox and the fuel control assemblies are attached to the engine as shown in Figure 6-4.

b. Accessory gearbox with battlefield damage can result in oil leaking which will eventually result in sufficient oil loss to cause an engine failure. Small oil leaks through small holes, cracks, and through loose jointed surfaces may be temporarily repaired by use of adhesive or sealant.

c. Similarly, the fuel control assembly which has sustained battle damage and has small fuel leaks must be repaired by adhesive or sealant. Fuel leaks must be stopped, otherwise they will cause engine failure and fires.

d. The following procedure gives an expedient repair to seal small holes, cracks, and loose joints which have not caused internal or major damage to gearbox or housings.

6-7. ACCESSORY GEARBOX AND FUEL CONTROL ASSEMBLY, MINOR LEAKS.

LIMITATIONS: These repairs are limited to expedient field repairs of battlefield damage. Once helicopter is flown back to home base and if time allows, the damaged gearbox or housing will be repaired/replaced by TM 55-1520-210-23.

PERSONNEL/TIME REQUIRED:

- 2 Soldiers
- 2 Hours

MATERIALS/TOOLS REQUIRED:

- Silicone Sealant (item 10, App C)
- Solvent (items 1, 76, 150, App C)
- 5-Minute Adhesive & Fiber Glass Patch or Zip-Patch Repair Kit (items 4, 5, & 63, App C)

PROCEDURAL STEPS:

1. Visually locate cracks wherever there is an oil leak on the fuel control housing or the accessory gearbox housing, Figure 6-4. If cracks are minor and no loose metal particles are suspected internally, then continue repair.

2. Check for internal damage or internal obstruction by manually turning the entire engine assembly which includes the turbines, compressor, the accessory gearbox, and the fuel control assembly. To do this, follow these steps:

a. Remove the tachometer generator, Figure 6-5.

b. Insert a 1/4 inch ratchet into the square slot which engaged with the tachometer shaft.

c. Turn the ratchet which in turn will rotate the entire engine assembly including the accessory gearbox and fuel control.

d. Listen and feel for any rubbing or scrapping noises in the accessory gearbox or fuel control assemblies. If no interference is suspected, then continue with fix. Reinstall the tachometer generator.

e. If interference, rubbing, and scrapping are felt, consider replacement of the component.

3. Clean area of crack thoroughly with solvent.

4. Apply sealant material or apply a fiberglass/epoxy patch over the crack.

5. Allow sealant or adhesive five minutes to cure.

6. Replenish any oil lost in system.

7. Record BDAR action taken. When mission is complete, as soon as practical, repair the equipment/system using standard maintenance procedures.

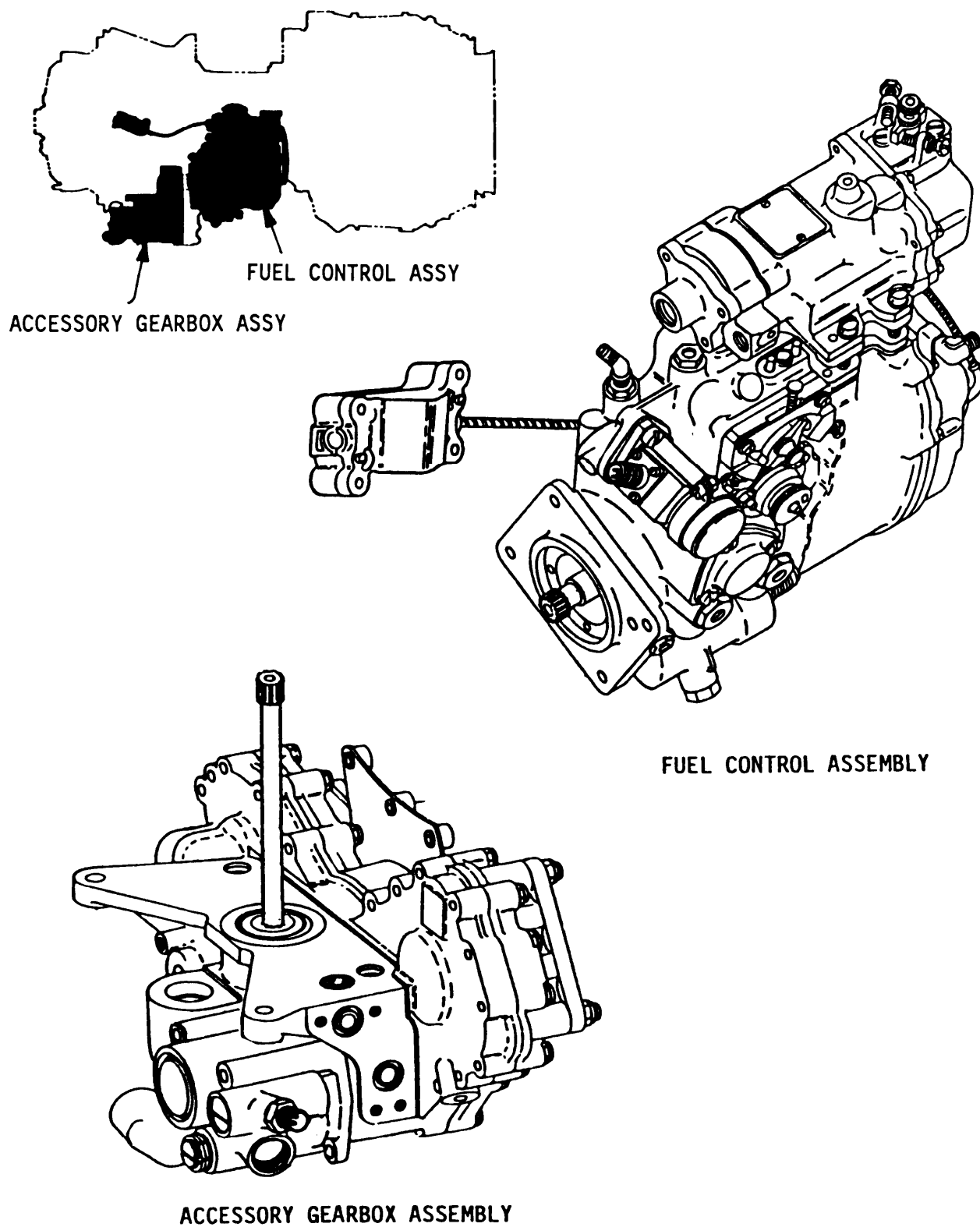

Figure 6-4. Fuel Control and Accessory Gearbox Assemblies

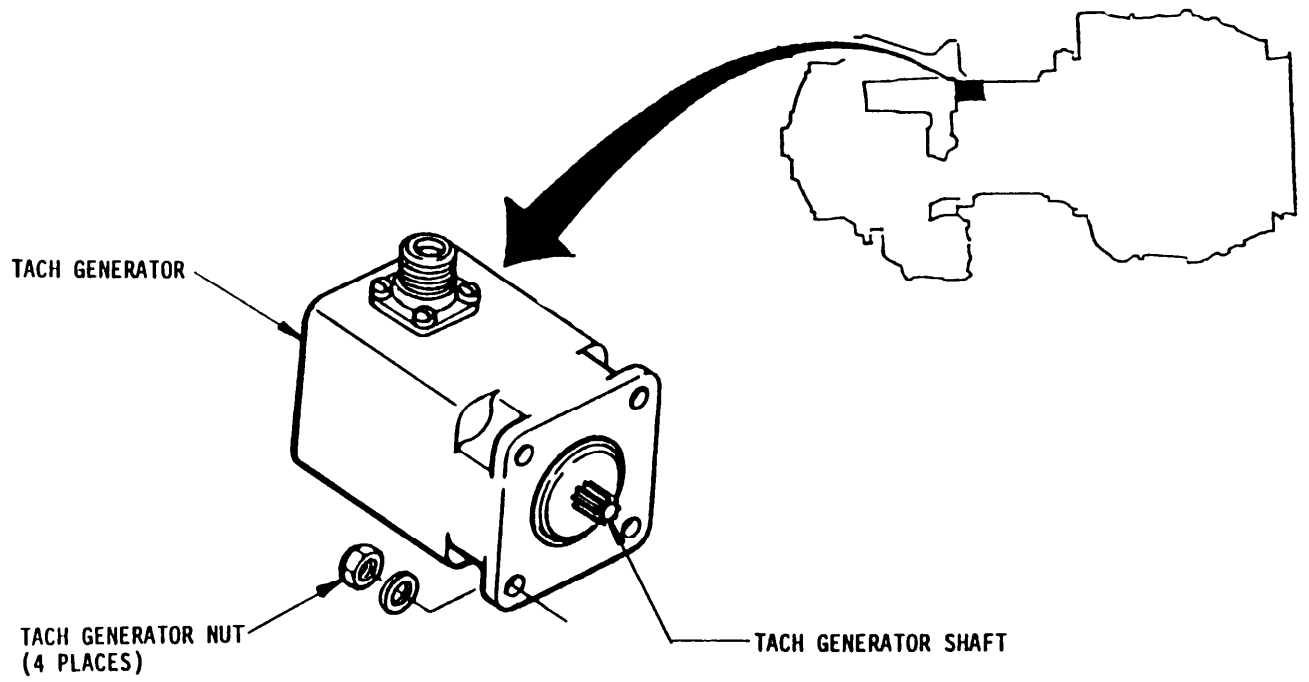

Figure 6-5. Tach Generator Removal

CHAPTER 7

ROTORS

BDAR FIXES SHALL BE USED ONLY IN COMBAT OR FOR TRAINING AT THE DISCRETION OF THE COMMANDER. (AUTHORIZED TRAINING FIXES ARE LISTED IN APPENDIX E.) IN EITHER CASE, DAMAGES SHALL BE REPAIRED BY STANDARD PROCEDURES AS SOON AS PRACTICABLE.

Section I. INTRODUCTION

7-1. SCOPE. This chapter contains BDAR fixes pertaining to the main rotor and tail rotor systems. Both main and tail rotor systems consist of two blades attached to the hub through grips. The rotating controls actuate the pitch (lift) of the blades. Because of the dynamic loads imposed on the rotor heads system, the only BDAR fixes authorized are on the blades of the main rotor and tail rotor. Any other damage to critical parts will require replacement per TM 55-1520-210-23.

7-2. ASSESSMENT PROCEDURES. Refer to Table 7-1.

7-30 REPAIR PROCEDURE INDEX.

	PARA.
Main Rotor Blades.	7-5

Section II. MAIN ROTOR BLADES

7-40 GENERAL. Each main rotor blade is a semi-rigid all metal bonded assembly. Battle damage in noncritical areas of the blades may be repaired by the BDAR fixes in this section. The only areas authorized for repairs is the honeycomb area, one inch away from solid aluminum extruded pieces such as the doublers, spar, trailing edge, and the blade tip. Dents and bends in the skin of blade where there are no cracks or breaks are deferrable damage. Refer to TM 55-1520-210-23.

LIMITATIONS: Repairs to one or both of the damaged blades may cause an unbalanced rotor system. A very badly unbalanced rotor head could cause undue stress on the helicopter's structure by excessive vibrations. Limits of flight duration should be considered in such cases. Limit repair to one time flight.

PERSONNEL/TIME REQUIRED:

- 2 Soldiers
- 15 Minutes

MATERIALS/TOOLS REQUIRED:

- Tape (items 153, 156, App C)

7-5. MAIN ROTOR BLADE, DAMAGE HOLES OF 1 INCH DIAMETER OF LESS. See Figure 7-1.

Table 7-1. Assessment Procedures

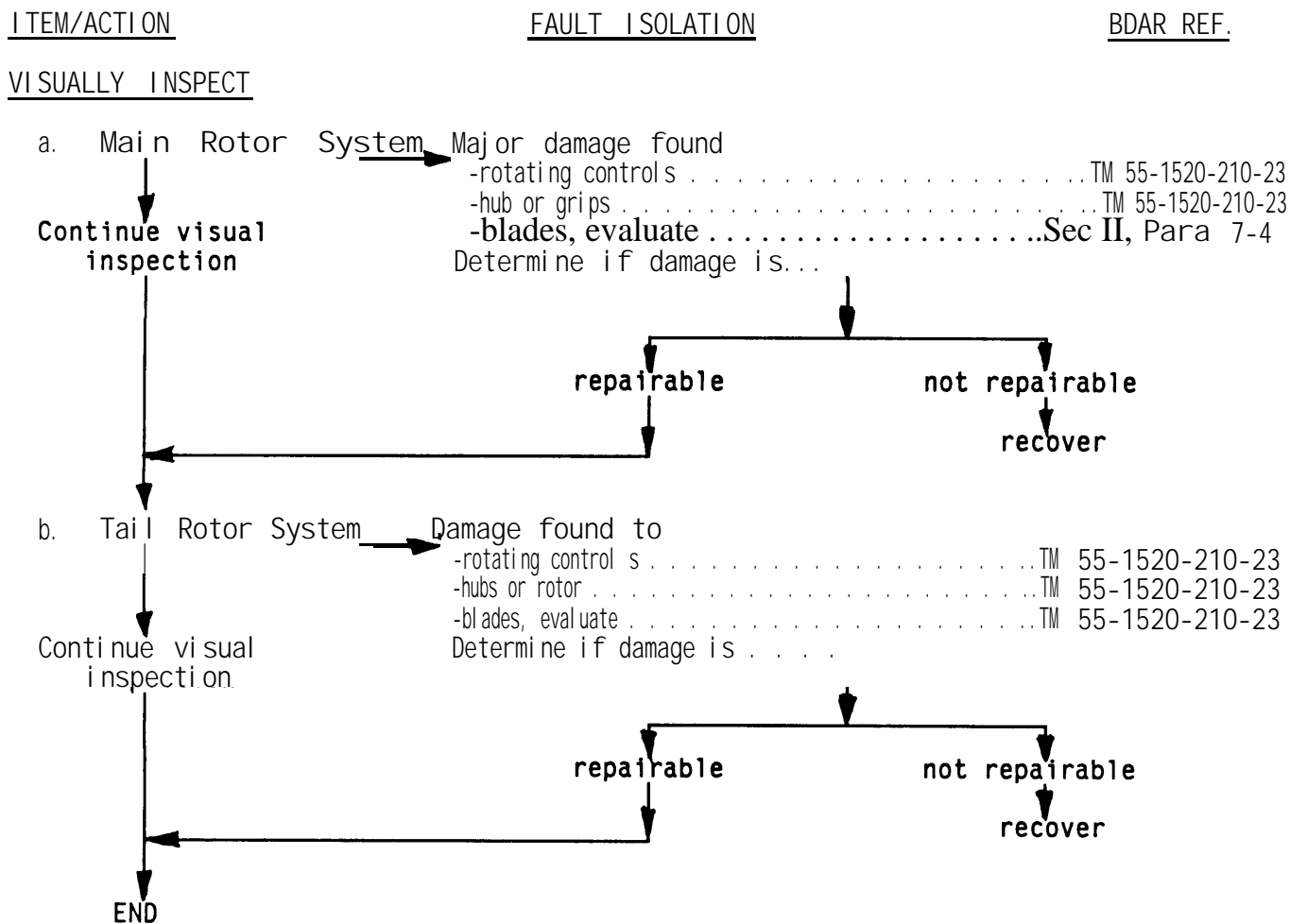

PROCEDURAL STEPS:

1. Position blades for access to damaged area. Support blades to prevent movement and drooping.
2. Smooth the damaged area, removing all rough edges with an abrasive grit cloth.
3. Clean area around damage and completely around blade where tape is to be applied with cleaning solvent.
4. Cover the damaged area (hole) with a chord wise layer of green cloth or aluminum duct tape. Cover top and bottom of blade if damage is through both skins. Extend ends of tape 2 inches beyond area of damage.
5. Wrap a second layer of tape chord wise over the first layer and around the entire blade, Figure 7-1. Overlap ends by 3 inches with outside edge of top toward trailing edge.
6. Adjust blade balance by adding approximately the same amount of tape wraps to the opposite blade at approximately the same distance away from the hub. Balance procedures for rotor head are specified in TM 55-1520-210-23.
7. Record BDAR action taken. When mission is complete, as soon as practical, repair the equipment/system using standard maintenance procedures.

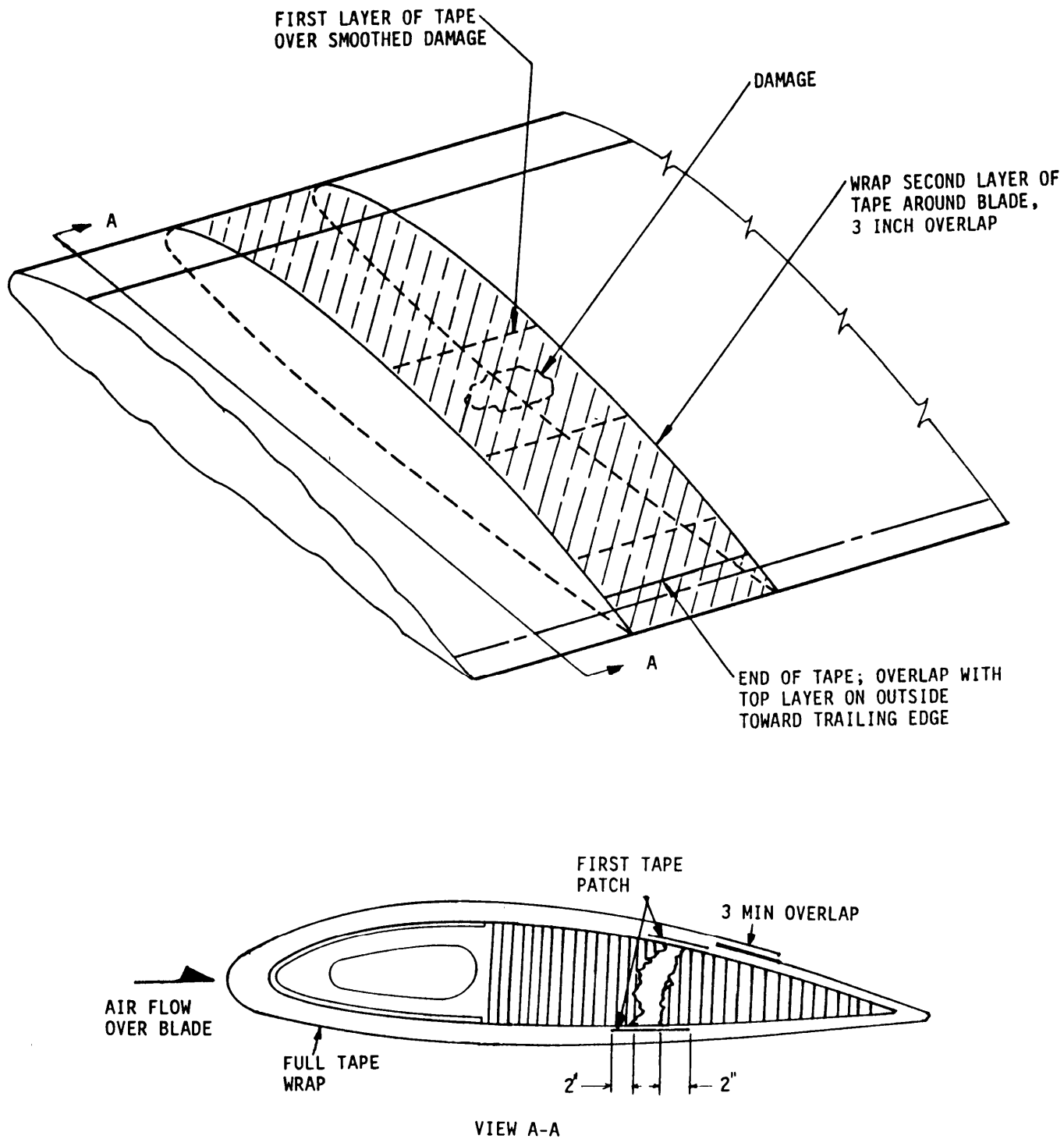

Figure 7-1. Blade Repair by Application of Tape

CHAPTER 8

DRIVE TRAIN SYSTEMS

**BDAR FIXES SHALL BE USED ONLY IN COMBAT OR FOR TRAINING
AT THE DISCRETION OF THE COMMANDER.
(AUTHORIZED TRAINING FIXES ARE LISTED IN APPENDIX E.)
IN EITHER CASE, DAMAGES SHALL BE REPAIRED BY STANDARD
PROCEDURES AS SOON AS PRACTICABLE.**

Section I. INTRODUCTION

8-1. SCOPE.

a. The purpose of this chapter is to provide BDAR Instructions for the drive train system.

b. The drive train system does not lend itself well to BDAR type repairs. This is due to its designed function and its importance to the basic airworthiness of the helicopter.

c. In most instances, the only recommended repair option is to replace or repair the damage by standard maintenance listed in TM 55-1520-210-23 or TM 55-1500-204-25/1.

d. There are several limited repairs that have been approved for evacuation purposes only and are listed in this chapter.

8-2. ASSESSMENT PROCEDURES. Refer to Table 8-1.

8-3. REPAIR PROCEDURE INDEX.

PARA .

Main Transmission Cases, Leak Through Small Holes and Cracks in Case Walls	8-5
Transmission Oil Pressure Switch Leak.	8-6
Transmission Oil Pressure Transmitter Leak	8-7
External Oil Filter Leak	8-8
Tail Rotor Driveshaft Sections, Minor Damage	8-10
Tail Rotor Driveshaft Sections, Moderate Damage.	8-11
Gearboxes, Small Leaks Through Case Holes and Cracks.	8-13

Section II. MAIN TRANSMISSION ASSEMBLY

8-4. GENERAL. Battlefield damage to the transmission can cause external damage (e.g., to the case, oil lines, filter assy and oil cooler). Severe external case damage will probably be accompanied by internal damage to the transmission. Internal damage to the transmission is normally too severe to fix with BDAR actions. This section will only deal with minor damage to the external case walls and to small components externally mounted on or about the main transmission.

8-5. MAIN TRANSMISSION CASES, LEAK THROUGH SMALL HOLES AND CRACKS IN CASE WALLS. Minor external damage to case walls in items 1, 2, 3, 4, 5, and 7 of Figure 8-1 can be repaired by the following procedure. These repairs are designed to eliminate oil loss to the transmission system and not to repair or replace any lost function or structural strength of the castings. Any major damage to case will reduce the structural strength of the case and will affect safety of flight. In this case, component must be replaced.

Table 8-1. Assessment Procedures

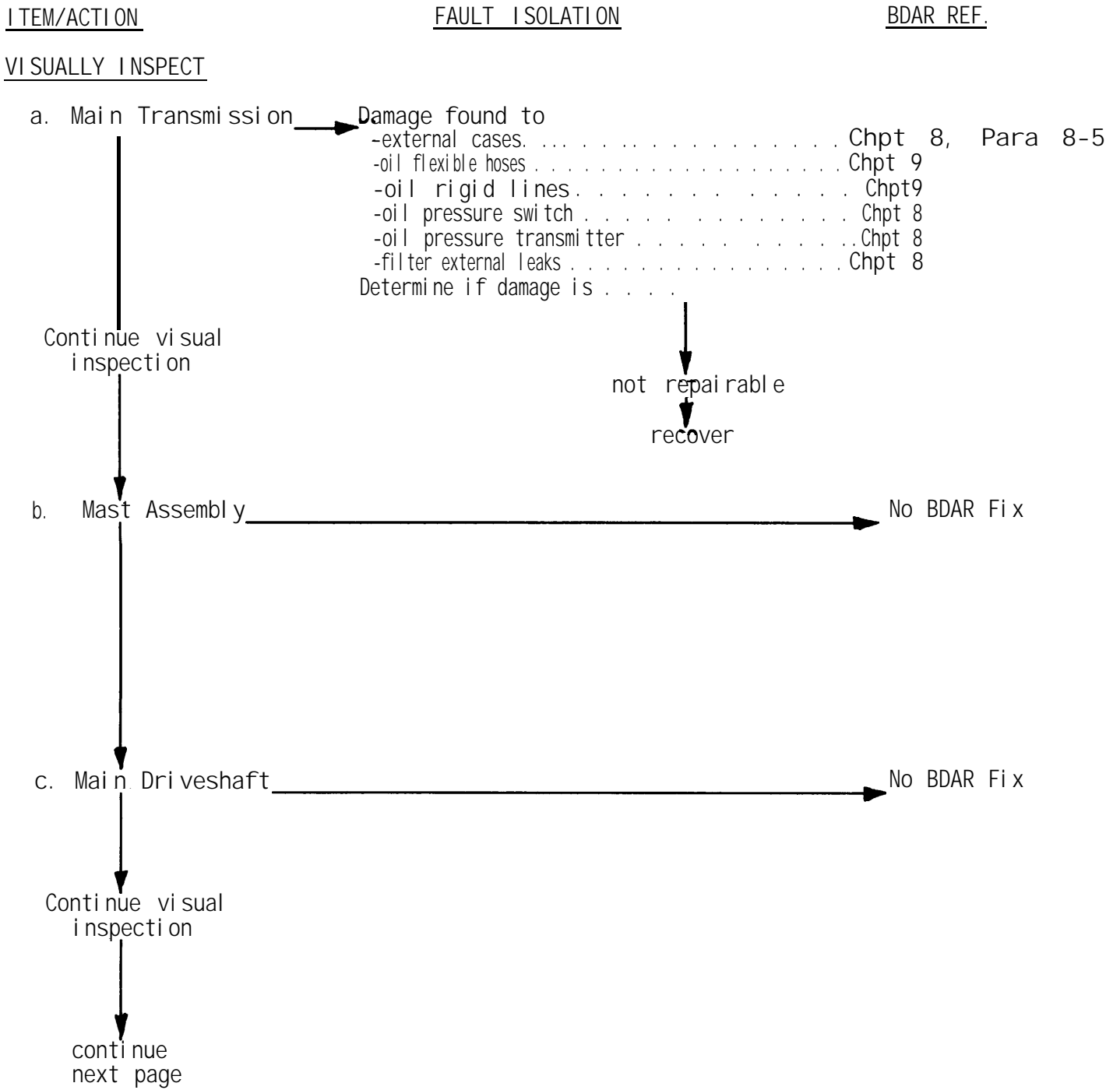
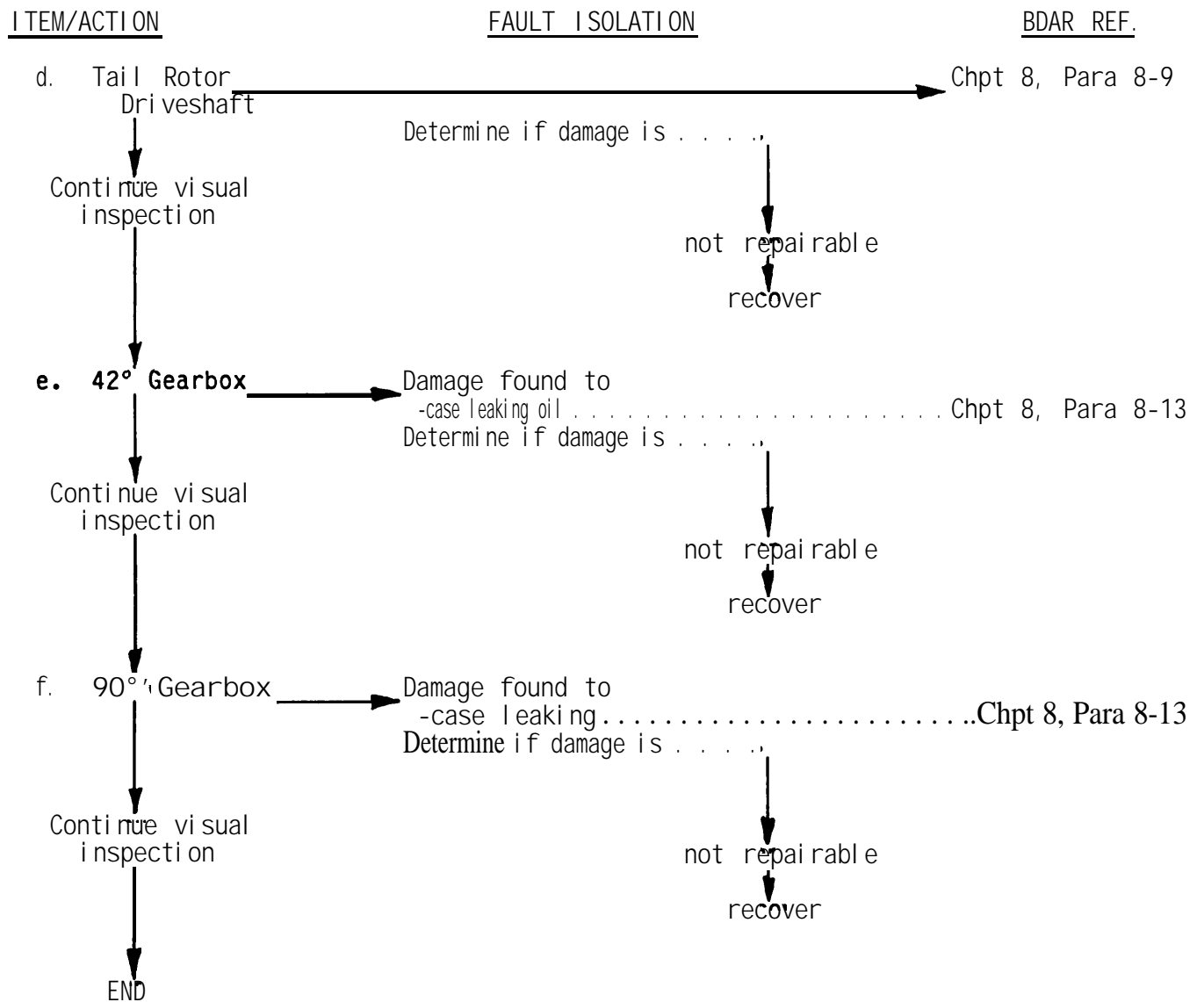

Table 8-1. Assessment Procedures (Cork)



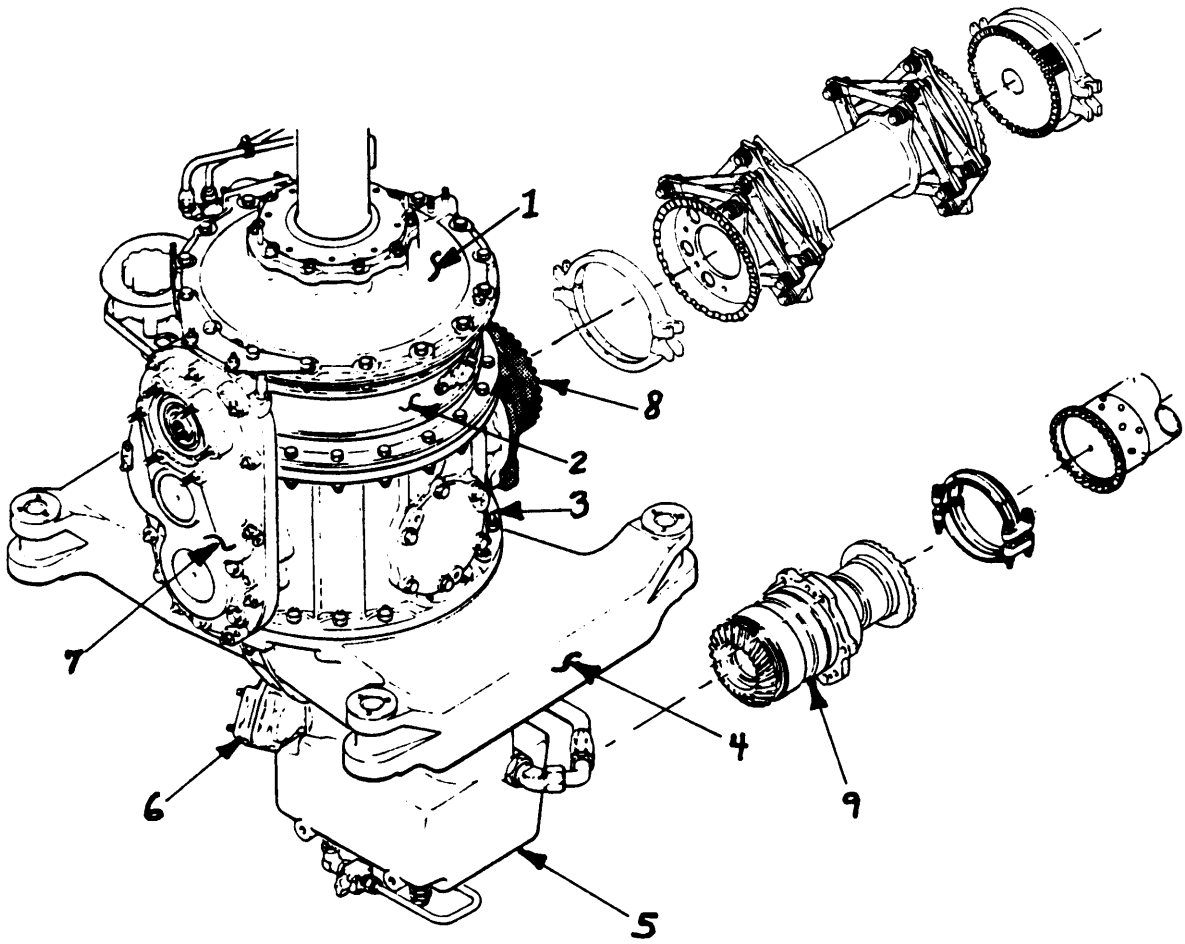
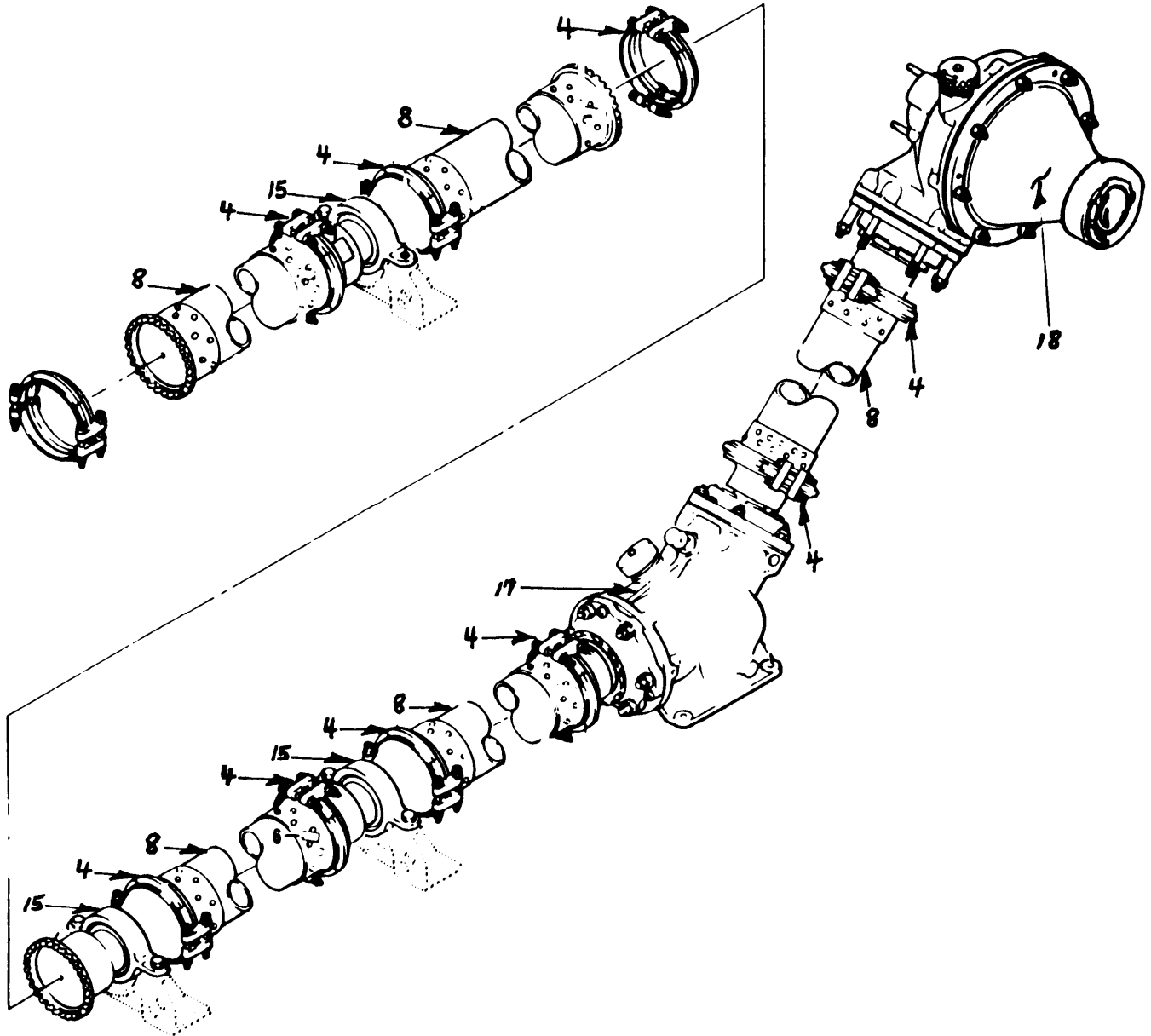

Figure 8-1. Drive Train System, Major Components (Sheet 1 of 2)



- | | | |
|-------------------------|---------------------------|---------------------------|
| 1. Mast Assy | 8. Tail Rotor Driveshaft | 13. Generator Drive Quill |
| 2. Transmission Assy | Section | 14. Sleeve |
| 3. Input Drive Quill | 9. Tail Rotor Drive Quill | 15. Hanger Assy |
| 4. Clamp Set | (mates to sump case) | 16. Support |
| 5. Main Driveshaft Assy | 10. Support Case | 17. Intermediate (45°) |
| 6. Retaining Bolt | 11. Sump Case | Gearbox Assy |
| 7. Engine Driveshaft | 12. Hyd Pump & Tachometer | 18. Tail Rotor (90°) |
| Adapter | Drive Quill | Gearbox Assy |

Figure 8-1. Drive Train System, Major Components (Sheet 2 of 2)

LIMITATIONS:

- Major damage to transmission which indicates complete loss or failure of lubrication system will require application of emergency flight procedures in TM 55-1520-210-10. Aircraft usage should be limited to one time flight for self-recovery. Damaged component should be replaced per TM 55-1520-210-23 as soon as practical.
- Minor case damage with evidence of no internal damage can be repaired without any aircraft restrictions. On such minor damage in which oil leak is very minor, consideration of deferring repairs should be given. Small oil leaks can be tolerated. Leakage rate should be inspected after each flight.

MATERIALS/TOOLS REQUIRED:

- Abrasive Cloth (item 121, App C)
- Adhesive Repair Kit, Zip-Patch (item 5, App C)
- Solvent Cleaner (items 1, 76, App C)
- Zinc Chromate Putty (item 90, App C)

PROCEDURAL STEPS:

1. Inspect the damaged area for internal damage to gears, shafts, etc. Remove any loose metal or shrapnel from inside the cases if possible. If no internal or major structural damage exists, prepare to apply a quick drying patch to the damage hole or crack to stop oil leak.
2. Drain oil from system if necessary. Remove oil from damaged area by cleaning with solvent. If time permits, abrade the area around the holes or cracks with abrasive cloth. If necessary, remove sharp edges or protrusions from damaged hole.

3. Make sure that no oil is flowing from damaged area. If oil is flowing, repair cannot continue until oil flow is stopped. Stop oil flow using whatever means are available (e.g., zinc chromate putty or tape) to temporarily plug and stop small oil flows.

4. Clean a border at least 2 inches wide all the way around the damaged area. If zinc chromate putty was used to plug leak, do not clean the area directly over the putty.

5. Place an adhesive patch using repair kit (item 5, App C) over the damaged area. Follow the manufacturer's instructions in adhesive repair kit. Let patch cure for five minutes.

7. Start the aircraft engine and ground run transmission. Monitor/inspect the repair area for five minutes.

8. Record BDAR action taken. When mission is complete, as soon as practical, repair the equipment/system using standard maintenance procedures.

8-6. TRANSMISSION OIL PRESSURE SWITCH LEAK. If transmission oil is being lost due to damage of the oil pressure switch (1, Figure 8-2), eliminate switch from oil system.

LIMITATIONS: The XMSN OIL PRESS warning segment at caution panel would be rendered inoperative. A low oil pressure condition would be indicated only at the transmission oil pressure indicator on instrument panel.

PERSONNEL/TIME REQUIRED:

- 1 Soldier
- 15 Minutes

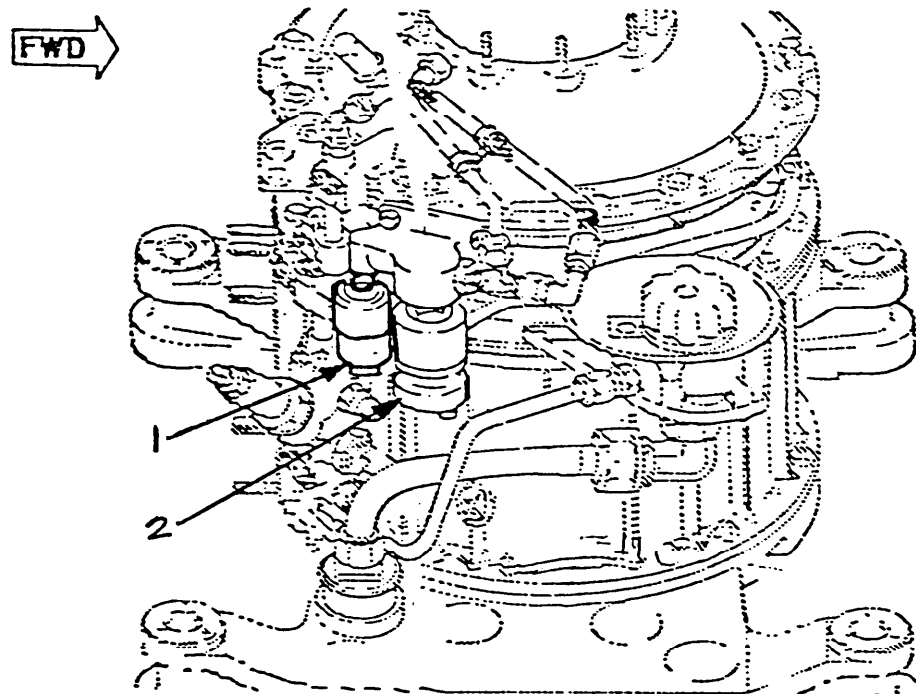

1. Transmission Oil Pressure Switch
2. Transmission Oil Pressure Transmitter

Figure 8-2. Pressure Switch and Transmitter

TM 55-1520-210-BD
DRIVE TRAIN

MATERIALS/TOOLS REQUIRED:

- Fluid Liner Repair Kit (item 4, Sec I, App B)
- Open End Wrenches (items 257-267, Sec II, App B)
- Pliers (items 124-135, Sec II, App B)
- Side Cutters (item 126, Sec II, App B)
- Tie Wraps (items 165, 166, App C)

PROCEDURAL STEPS:

1. Cut safety wire and remove electrical conductor from pressure switch (1).
2. Cut safety wire and remove pressure switch and o-ring. Retain o-ring.
3. Install cap plug with o-ring where switch was removed.
4. Check for leaks and add oil to XMSN if necessary.
5. Secure loose electrical connector with tie wraps.
6. Record BDAR action taken. When mission is complete, as soon as practical, repair the equipment/system using standard maintenance procedures.

8-7. TRANSMISSION OIL PRESSURE TRANSMITTER LEAK.

GENERAL INFORMATION: If oil is being lost due to damage at oil pressure transmitter (2, Fig 8-2), eliminate transmitter from oil system.

LIMITATIONS: The transmission oil pressure indicator on instrument panel would be rendered inoperative. The XMSN OIL PRESS warning segment at caution panel will only monitor transmission low oil pressure. There would be no early warning capability if a high oil pressure condition was present.

PERSONNEL/TIME REQUIRED:

- 1 Soldier
- 15 Minutes

MATERIALS/TOOLS REQUIRED:

- Open End Wrench (items 257-267, Sec II, App B)
- Pliers (items 124-135, Sec II, App B)
- Fluid Line Repair Kit (item 4, Sec I, App B)
- Side Cutters (item 126, Sec II, App B)
- Tie Wraps (items 165, 166, App C)

PROCEDURAL STEPS:

1. Procedural steps are the same as in paragraph 8-6 except that they would be applicable to the transmitter (2, Fig 8-2).
2. Record BDAR action taken. When mission is complete, as soon as practical, repair the equipment/system using standard maintenance procedures.

8-8. EXTERNAL OIL FILTER LEAK.

GENERAL INFORMATION: If oil is being lost due to damage to the oil filter (4, Fig 8-3) assembly and there is no damage to adjacent oil hoses and lines, isolate oil filter from oil system by repositioning input oil line to bypass filter. See Figure 8-3.

LIMITATIONS. Fine suspended matter would not be filtered from oil system, and would increase the wear of gears and bearings.

PERSONNEL/TIME REQUIRED:

- 1 Soldier
- 15 Minutes

MATERIALS/TOOLS REQUIRED:

- Open End Wrenches (items 257-267, Sec II, App B)
- Tie Wraps (items 165, 166, App C)

PROCEDURAL STEPS:

1. Loosen nut (15) and valve (16) installation.
2. Loosen nut (18) and disconnect tube assembly (17) from elbow (1) on inlet side of filter assembly (4).

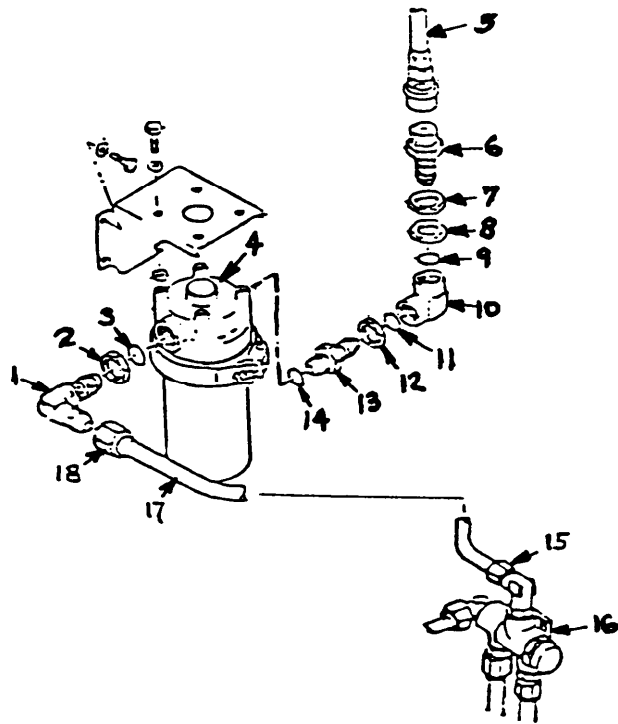

UNALTERED INSTALLATION

1. El bow
2. Nut
3. O-Ri ng
4. Fil ter Assy
5. Hose Assy
6. Coupl ing (or Ni ppl e)
7. Nut
8. Nut
9. O-Ri ng
10. El bow
11. O-Ri ng
12. Nut
13. Ni ppl e
14. O-Ri ng
15. Nut
16. Thermo Val ve
17. Tube Assy
18. Nut

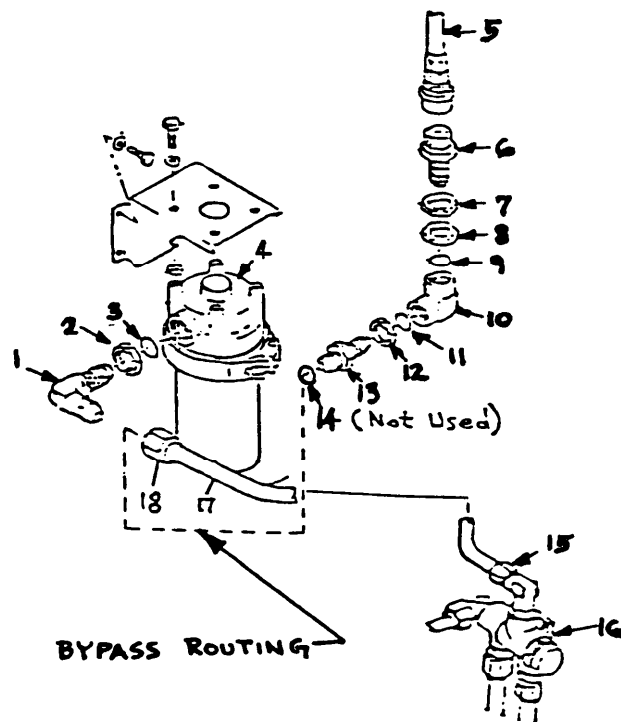

ALTERED INSTALLATION

Figure 8-3. Transmission External Oil Filter Bypass

3. Disconnect hose assembly (5) from coupling (6) on outlet side of filter assembly (4).
4. Loosen and disconnect items 6 thru 14 from filter assembly (4). Discard o-ring (14).
5. Reassemble items 6 thru 13 in same configuration as before and tighten.
6. Attach but do not tighten loose end (18) of hose assembly (17) to nipple (13). Do not use o-ring (14) on tube nipple (13).
7. Rotate tube assembly (17) to a position above filter assembly (4) and connect hose assembly (5) to coupling (6).
8. While holding tube assembly (17), elbow (10), and hose assembly (5) in the best position allowed, tighten nuts (18 and 51).
9. Check for any chafing conditions and correct by use of tie wraps, etc.
10. Check for leaks.
11. Record BDAR action taken. When mission is complete, as soon as practical, repair the equipment/system using standard maintenance procedures.

Section III. TAIL ROTOR DRIVESHAFT ASSEMBLY

8-9. GENERAL. The tail rotor drive-shaft rotates at approximately 4300 rpm. Damage to the tail rotor driveshaft train, which results in metal loss or bending of shafts, can cause an out of balance condition. This condition can damage the bearings, bearing hangers, couplings, gearboxes and eventually lead to complete shaft failure (break and separation). Any repair should therefore include the restoration of balance. Major damage which is not covered in this section will require replacement of the damaged component.

8-10. TAIL ROTOR DRIVESHAFT SECTIONS, MINOR DAMAGE.

GENERAL INFORMATION: Small arms fire and projectile passing through the driveshaft will cause minor damage. Entrance and exit holes (2 holes max) each not exceeding 0.625 inch diameter will be acceptable, Figure 8-4.

OPTION 1: Damage through the approximate center of driveshaft with holes approximately 180 degrees apart. No restoration of balance required.

LIMITATIONS: Emergency one time flight and/or for recovery of aircraft. Inspect damaged area prior to flight. Prior to takeoff, functionally test the driveshaft by running the helicopter's engine for three minutes minimum at normal operating speed. Some abnormal vibrations may be present. Consideration should be given to abort flight if vibrations will cause loss of flight control.

PERSONNEL/TIME REQUIRED:

- 1 Soldier
- 30 Minutes

MATERIALS/TOOLS REQUIRED:

- Tape, Green Cotton (item 156, App C)

PROCEDURAL STEPS:

1. Impact of projectile may cause the driveshaft to bend. Check the driveshaft for runout in the center. Maximum runout should not exceed 0.070 inch total indicator reading.
2. Inspect the damaged area for cracks radiating out of hole. All damage including cracks shall not exceed 0.625 inch in diameter. Two holes maximum are allowed.

3. Do not remove any significant amounts of metal as this will destroy the shaft's balance. Remove very small loose metal, burrs, and slivers from the exit hole.

4. Large exit hole petals (Fig 8-4) should be straightened by light hammer tapping. Tap the petals relatively smooth back to original surface. Leave the entrance hole petals which point inward towards center of driveshaft alone.

5. Wrap tape around the shaft over the holes. Tape must be wrapped opposite direction of rotation. Wrap three layers deep. Tape will not add structural strength to the driveshaft but will keep air from whistling through the holes.

6. Record BDAR action taken. When mission is complete, as soon as practical, repair the equipment/system using standard maintenance procedures.

OPTION 2: Projectile damage through driveshaft off of center. Entrance and exit holes are not to be closer than two hole diameters between each other. Each hole not to exceed 0.625 inch diameter. Restoration of balance will be required by drilling extra lightening holes.

LIMITATIONS: Emergency one time flight and/or for recovery of aircraft. Inspect damaged area prior to flight. Prior to takeoff, functionally test the driveshafts by running the helicopter's engine for three minutes minimum at normal operating speed. Some abnormal vibrations may be present. Consideration should be given to abort flight if vibrations will cause loss of flight control.

PERSONNEL/TIME REQUIRED:

- 2 Soldiers
- 1 Hour

MATERIALS/TOOLS REQUIRED:

- . Drill Bit Set (item 67, Sec II, App B)
- . Drill Motor (item 69, Sec II, App B)
- . Ruler (flexible)
- . Tape, Green Cotton (item 156, App C)

PROCEDURAL STEPS:

1. Impact of projectile may cause the driveshaft centerline to bend. Check the driveshaft for runout in the center. Maximum runout should not exceed 0.70 inch total indicator reading.
2. Inspect the damaged area for cracks radiating out of hole. All damage including cracks shall not exceed 0.625 inch in diameter after rework. Two holes maximum are allowed. Holes minimum edge to edge distance is two hole diameters, Figure 8-5.
3. Remove hole petals, burrs, and cracks by rounding up the holes with files and abrasive cloth. Do not exceed 0.625 inch in diameter after repair. Both holes should be approximately the same size in square inches of area in order to continue the restoration of balance by this procedure.
4. Restore balance in shaft as follows:
 - a. Measure arc "S" as shown in Figure 8-5, view A-A.

NOTE

If the two holes in driveshaft

are not in a single plane perpendicular to the driveshaft axis, the arc "S" measurement will be measured to a constructed centerline as shown in Figure 8-5. The arc "S" measurement must be a single plane perpendicular to the driveshaft axis for the following procedure to work correctly.

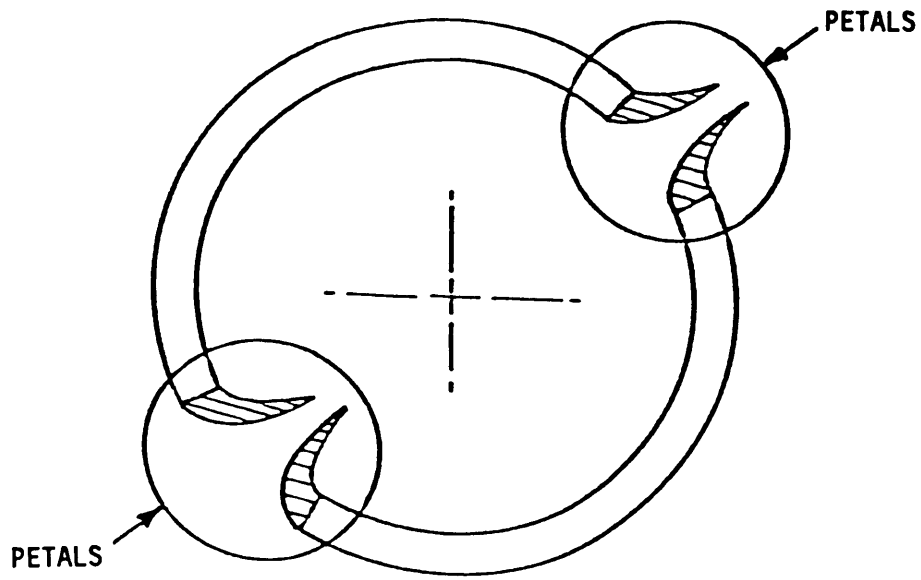

A. DAMAGED SHAFT

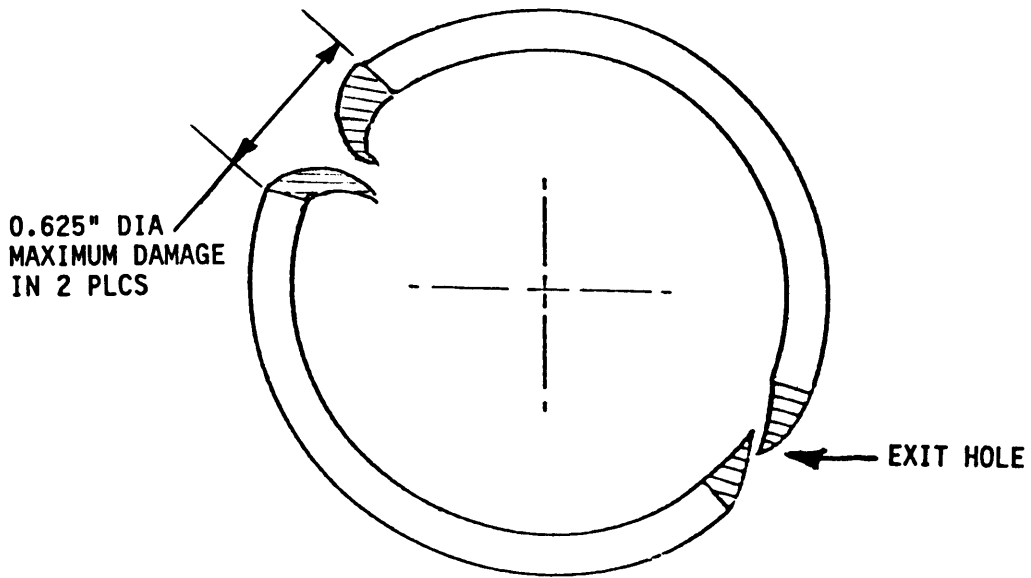

B. EXIT HOLE PETAL STRAIGHTENED
TO A RELATIVELY SMOOTH SURFACE

Figure 8-4. Damage Passing Through Center of Shaft

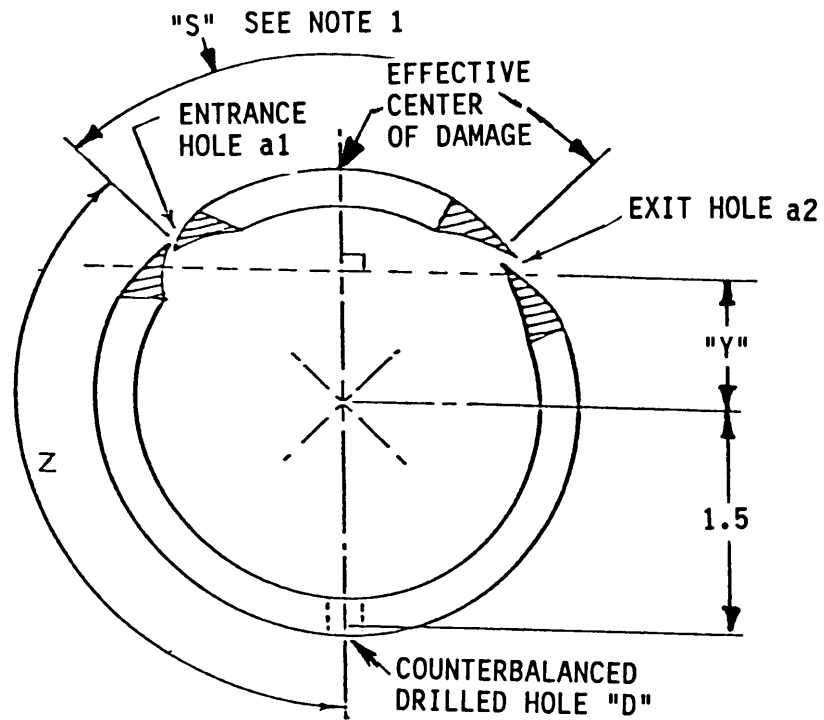

NOTE

ARC MEASUREMENT "S" IS IN A PLANE THAT IS PERPENDICULAR TO AXIS DRIVESHAFT.

VIEW A-A

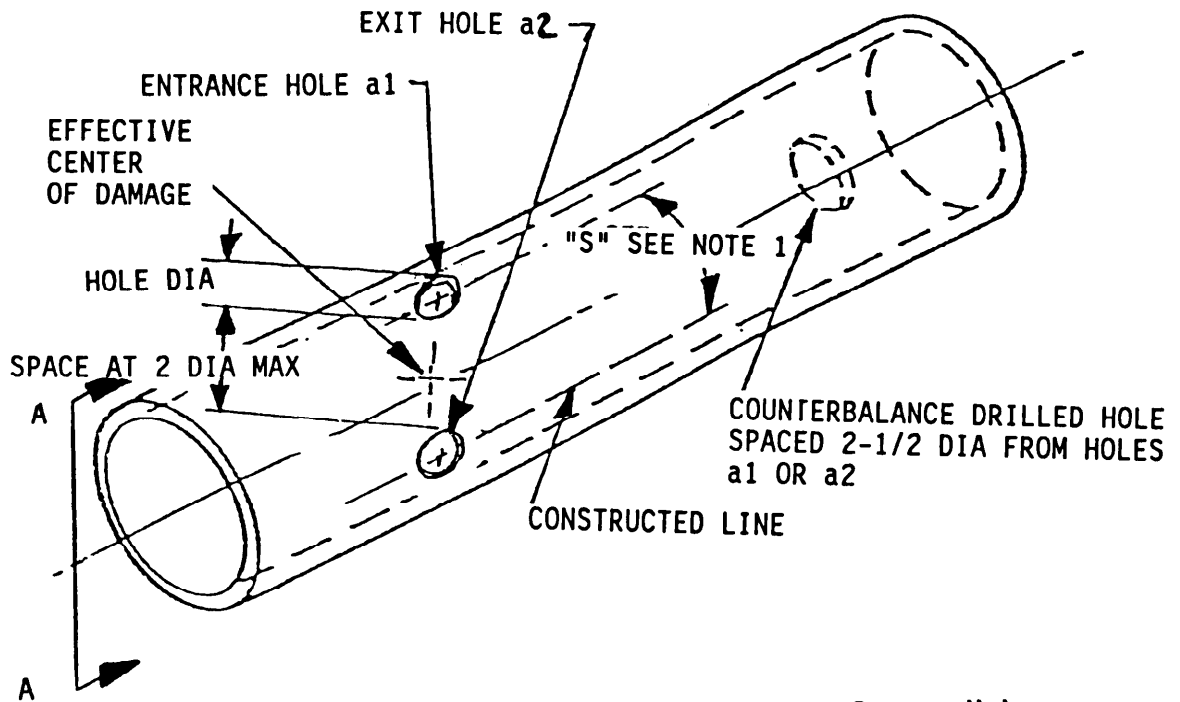

Figure 8-5. Balance Restoring Repair for Damage Not Passing Through the Center of Shaft

b. Find the value of "Y," Figure 8-5, view A-A, by using the "S" value measured in step a above and using the curve on Figure 8-6. This "Y" value will be used in the following step.

c. Estimate the amount of material loss in square inches of the entrance and exit holes (after rework). Let a_1 equal to the material lost in entrance hole and a_2 equal to material lost in exit hole. A counterbalance hole will have to be drilled to offset the loss of metal of holes a_1 and a_2 .

(1) To determine the area "A" of the hole to be drilled, use formula:

$$"A" = (a_1 + a_2) \times (Y/1.5)$$

(2) Use value "A" to determine the diameter "D" of the hole to be drilled. Use Figure 8-7.

(3) To determine the location of "D" hole to be drilled, use formula:

$$"Z" = 4.71 - \frac{(a_2S)}{(a_1 + a_2)}$$

Value "Z" will be the distance in inches measured in an arc from hole a_1 .

do Drill counterbalance hole "D" diameter at location "Z" as shown in Figure 8-5.

5. Record BDAR action taken. When mission is complete, as soon as practical, repair the equipment/system using standard maintenance procedures.

8-11. TAIL ROTOR DRIVESHAFT SECTIONS, MODERATE DAMAGE.

GENERAL INFORMATION: For any one single damage, the total damaged area is not to exceed one-third of the total cross-sectional area of the driveshaft, and a maximum surface area of 4.7 square inches, Figure 8-8. Maximum damage will be in the form of a hole with maximum diameter of 2.44 inches.

LIMITATIONS: Emergency one time flight and/or for recovery of aircraft. Inspect damaged area prior to flight. Prior to takeoff, functionally test the driveshaft train by running the helicopter's engine for three minutes minimum at normal operating speed. Some abnormal vibrations may be present. Consideration should be given to abort flight if vibrations will cause loss of flight control.

PERSONNEL/TIME REQUIRED:

- 2 Soldiers
- . 2 Hours

MATERIALS/TOOLS REQUIRED:

- . Drill Bit Set (item 67, Sec II, App B)
- . Drill Motor (item 69, Sec II App B)
- Hose Clamps (items 40, 41, App C)
- Rivets, Blind (items 94-114, App C)
- . Measuring Tape (item 121, App B)
- Sheet Metal (item 129, App C)

PROCEDURAL STEPS:

1. Inspect the damaged area, and measure to ensure that:

a. Damaged area does not reduce the cross section of the driveshaft by 33 percent in anyone plane per every 12 inches of driveshaft length.

b. The hole diameter (after clean-up) does not exceed 2.44 inches in diameter.

c. The driveshaft centerline to be straight with maximum runout of 0.07 inch total indicator reading taken anywhere along shaft.

2. Inspect the damaged area for cracks radiating out of hole. All damage including cracks shall not exceed 2.44 inches in diameter after rework.

3. Remove hole petals, burrs, and cracks by rounding up the hole with files and abrasive cloth. Remove the least amount of metal required to remove cracks. Do not exceed 2.44 inches in diameter after repair.

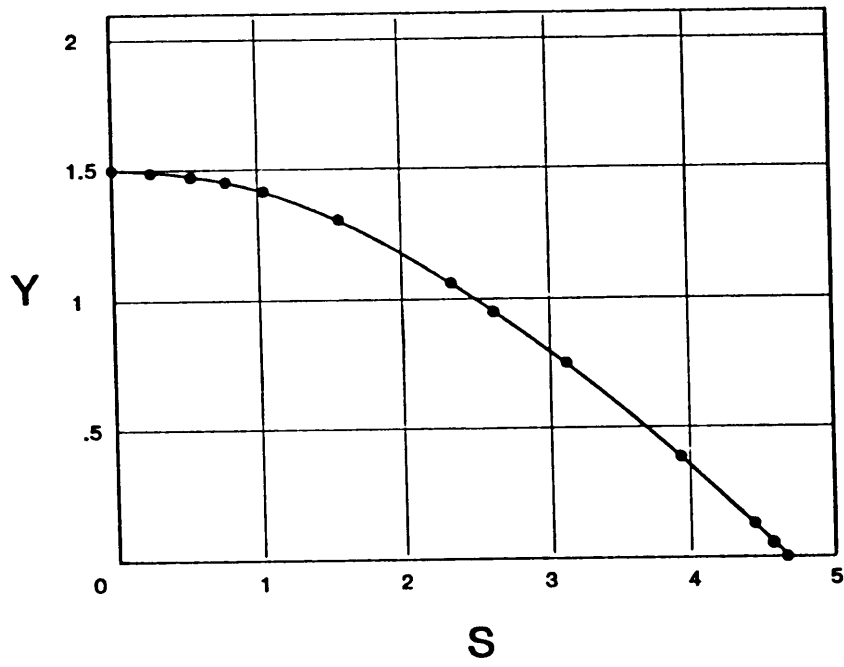

Figure 8-6. Y vs. S

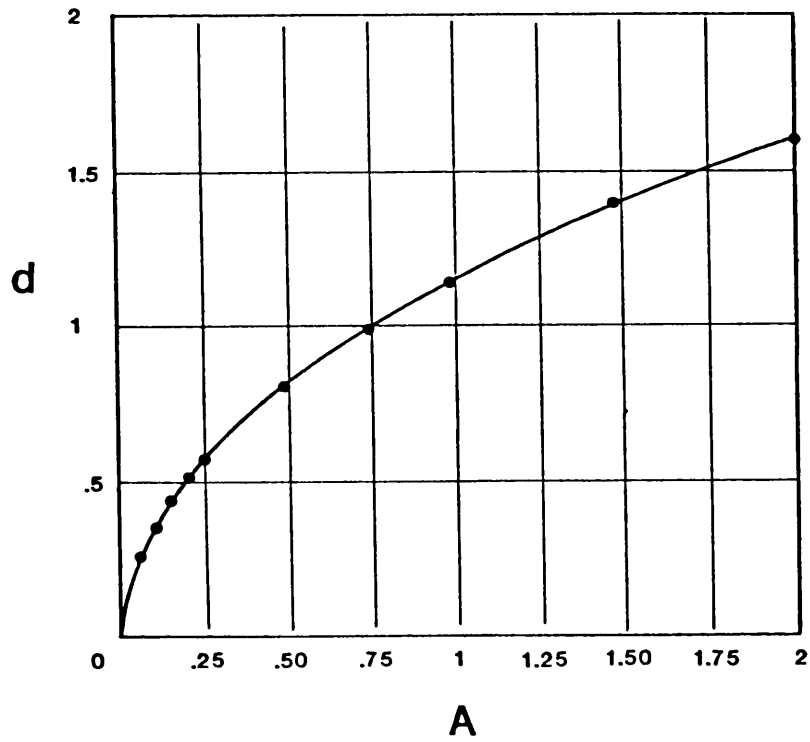

Figure 8-7. Area vs. Diameter

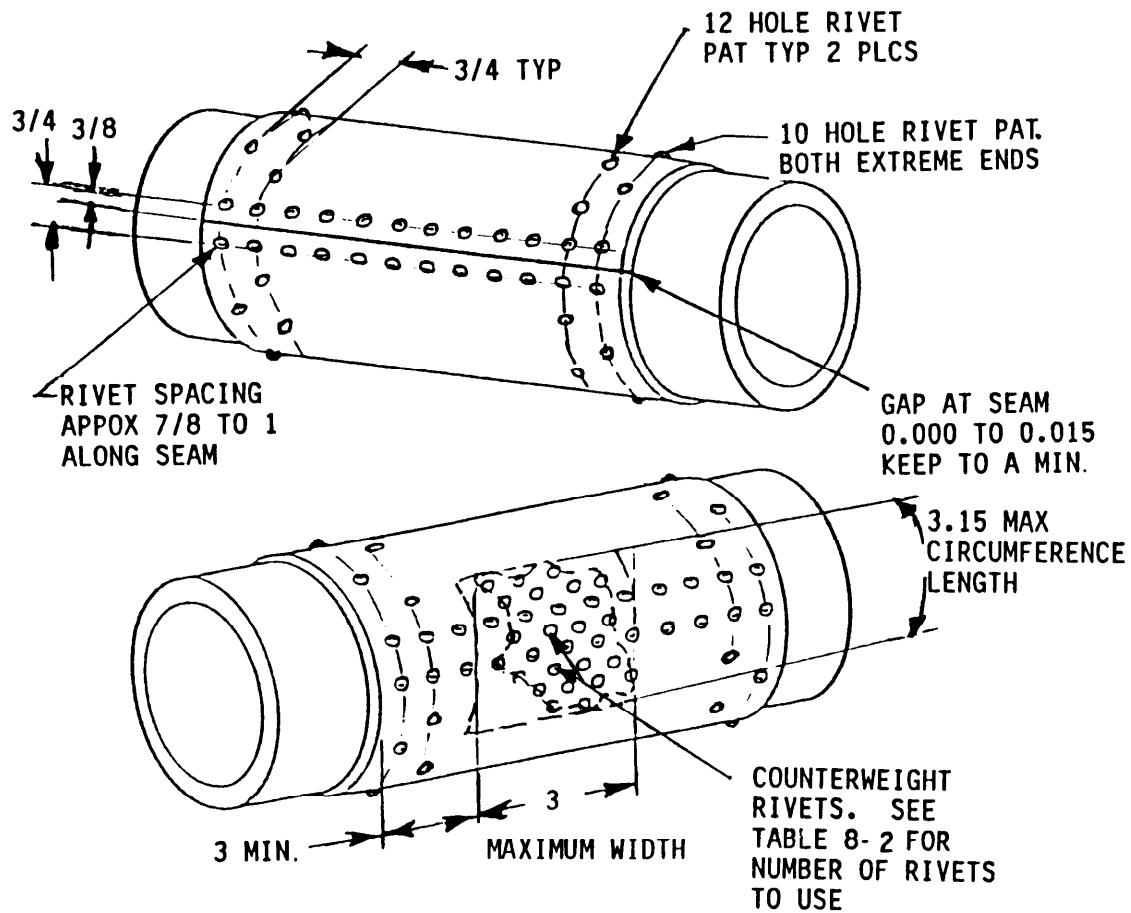
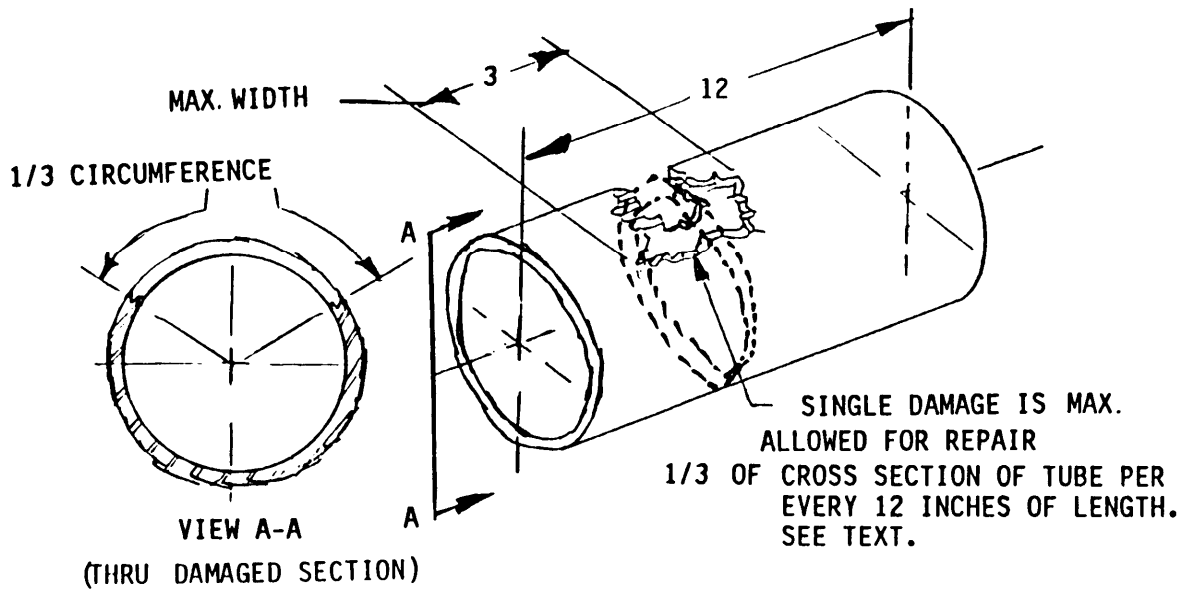

Figure 8-8. Repaired Shaft

4. Fabricate a sheet metal plate (item 129, App C) to wrap around over the damaged area. The length of the sheet metal plate should be approximately 9-7/16 Inches the shaft circumference. The width of the plate should extend at least 3 inches beyond each side of the damaged area.
5. Wrap and hold the sheet metal plate around the damaged portion of the drive-shaft using two or more hose clamps. The plate ends should come together on the opposite side, 180 degrees from the damage. Apply two rows of rivets on each end as shown in Figure 8-8. Apply two rows of rivets at the seams as shown in Figure 8-8.

6. Two rows of rivets (counterweight) are to be placed precisely 180 degrees opposite the rows which were used to secure the edge seam of the sheet metal plate.

7. To serve as counterweights for the missing metal in damaged area, install a number of rivets to compensate for lost weight. See Figure 8-9 and Table 8-2 for data on number of rivets required for given shaft missing area.

8. Record BDAR action taken. When mission is complete, as soon as practical, repair the equipment/system using standard maintenance procedures.

NOTE

It is very important that the seam of repair plate be as precise as possible in 180 degree opposite location from damage to keep shaft as close to balance as possible.

Section IV. INTERMEDIATE GEARBOXES

8-12. GENERAL. The 42 and 90 degree gearboxes are nonpressurized vented gearboxes with the bottom of gears immersed in oil. The oil quantity to fill both gearboxes is approximately one pint. If oil is being lost through battle damage, repair damage and replenish oil supply.

8-13. GEARBOXES, SMALL LEAKS THROUGH CASE HOLES AND CRACKS. The following repairs are designed to stop minor oil leaks and not to replace any lost function or structural strength of case.

LIMITATIONS: Minor case damage with evidence of no internal damage can be repaired without any aircraft restrictions. On such minor damage in which oil leaks are very minor, consideration to deferring repairs should be given. Small oil leaks can be tolerated. Leakage rate should be inspected at intervals.

PERSONNEL/TIME REQUIRED:

- 1 Soldier
- . 30 Minutes

Table 8-2. Shaft Area (in²) vs.
Number of Rivets

METAL LOSS AREA (IN ²)	NUMBER OF RIVETS 1/8 CHERRYMAX
1	5
2	10
3	14
4	19
5	24
6	29
7	33
8	38
9	43
10	48

Based on No. 1/8 in. cherrymax rivets.
4.77 rivets equal the same weight as 1 sq in. shaft.

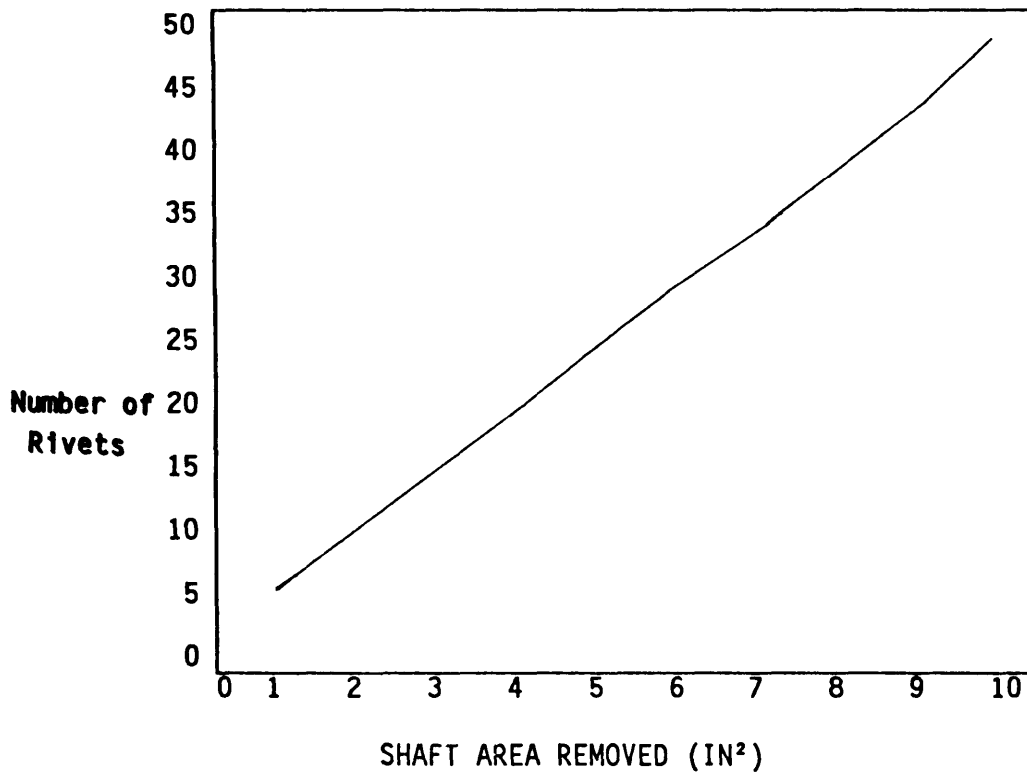

Figure 8-9. Shaft Area (in²) vs. Number of Rivets

MATERIALS/TOOLS REQUIRED:

- . Abrasive Cloth (item 121, App C)
- . Adhesive Repair Kit, Zip-Patch (item 5, App C)
- . Solvent Cleaner (items 1, 76, App C)
- Zinc Chromate Putty (Item 90, App C)

PROCEDURAL STEPS:

1. Inspect the damaged area for internal damage to gears, shafts, etc. Remove any loose metal or shrapnel from inside the cases if possible. If no internal or major structural damage exists, prepare to apply a quick drying patch to the damage hole or crack to stop oil leaks.
2. Drain oil from system if necessary. Remove oil from damaged area by using solvent cleaner. If time permits, abrade the area around the hoses or cracks with an abrasive cloth. If necessary, remove sharp edges or protrusions from damaged hole.
3. Make sure that no oil is flowing from damaged area. If oil is flowing, repair cannot continue until oil flow is stopped. Stop oil flow using whatever means are available (e.g., zinc chromate putty, or tape) to temporarily plug and stop small oil flows.
4. Clean a border at least 2 inches wide all the way around the damaged area. If zinc chromate putty was used to plug leak, do not clean the area directly over the putty.
5. Place an adhesive patch using adhesive repair kit (Zip-Patch) over the damaged area. Follow the manufacturer's instructions in adhesive repair kit. Let patch cure for five minutes.
6. Replenish any lost oil. If no oil supply is available, consider using engine oil from engine oil sump.
7. Start the aircraft engine and ground run transmission. Monitor/inspect the repair area for five minutes.
8. Record BDAR action taken. When mission is complete, as soon as practical, repair the equipment/system using standard maintenance procedures.

CHAPTER 9

HYDRAULIC AND PNEUMATIC SYSTEMS

BDAR FIXES SHALL BE USED ONLY IN COMBAT OR FOR TRAINING
 AT THE DISCRETION OF THE COMMANDER.
 (AUTHORIZED TRAINING FIXES ARE LISTED IN APPENDIX E.)
 IN EITHER CASE, DAMAGES SHALL BE REPAIRED BY STANDARD
 PROCEDURES AS SOON AS PRACTICABLE.

Section I. INTRODUCTION

9-10 SCOPE.

a. This chapter consists of BDAR that is generally confined to fixing battle damaged hydraulic components, lines, and bleed air system to sufficiently keep helicopter flying.

b. The procedures listed in this manual will help determine if:

- (1) Deferring repairs are possible.
- (2) Component or line replacement with new/used (salvaged) materials per TM 55-1520-210-23 is required.
- (3) Expedient BDAR repairs of components or lines are necessary. An expedient repair may be:
 - (a) Bypassing damaged component or line if necessary.
 - (b) Isolating damaged component or line if necessary.

9-2. ASSESSMENT PROCEDURES. Use assessment procedure, Table 9-1, to locate damage components or hydraulic line leaks. Use Figure 9-1 and schematic Figure 9-2 to guide you in identifying damaged areas and leaks. TM 55-1520-210-23 should be used in removal and replacement of components.

9-30 REPAIR PROCEDURE INDEX.

	<u>PARA.</u>
Reservoir (1, Fig 9-1) Leaks	9-5
Hydraulic Filter, Damage & Leaking	9-7
Relief Valve Leaking Hydraulic Fluid	9-9
Solenoid Valve Damaged to Leaking	9-11
Pressure Switch Damaged & Leaking	9-13
Check Valve Leaking	9-15
Armament Hydraulic System, Leaking	9-17
Metal Tube Leaking/Damaged	9-20
Bleed Air Lines Leaking	9-22
Bleed Air Fittings Damaged	9-24

Table 9-1. Assessment Procedures

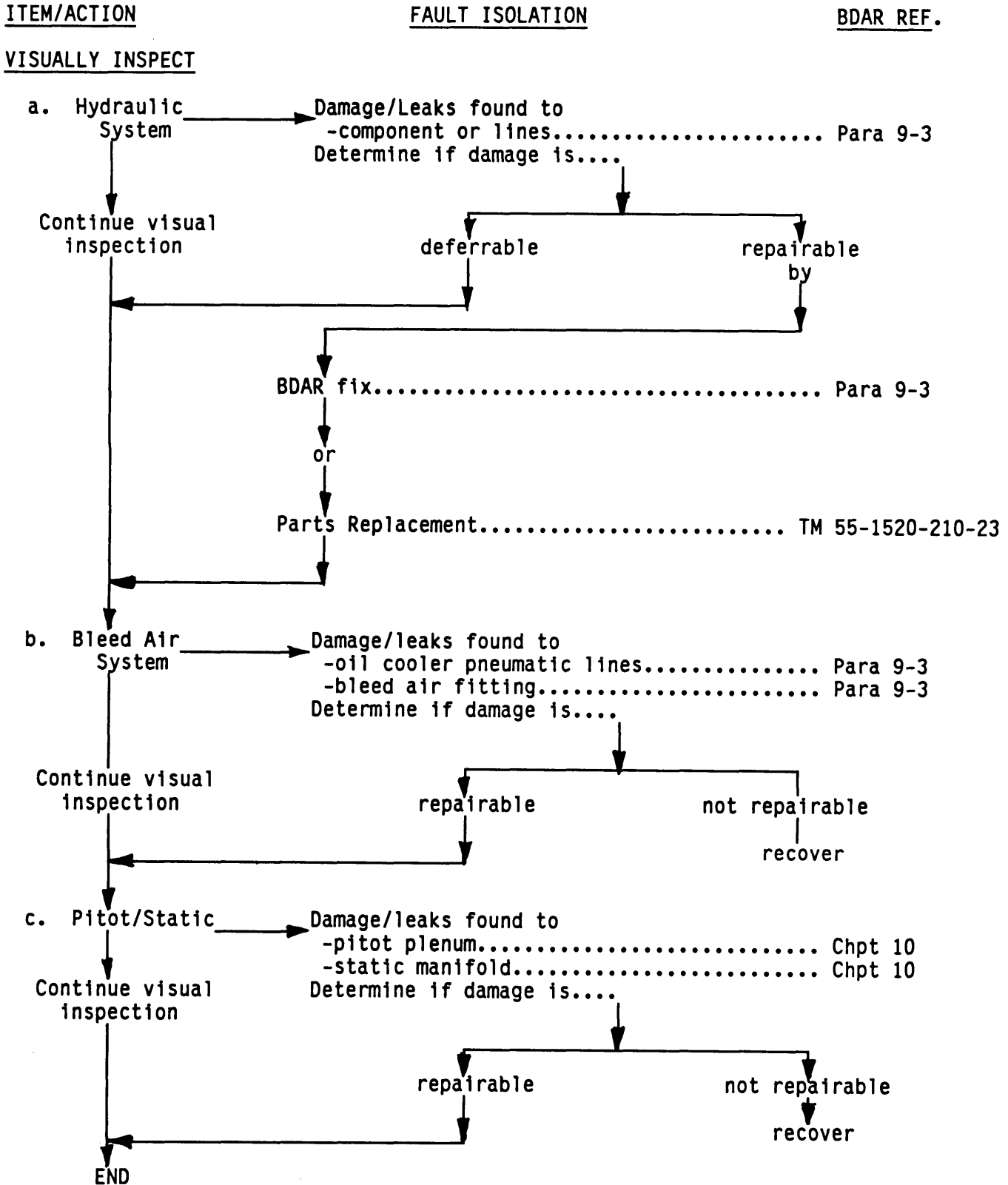

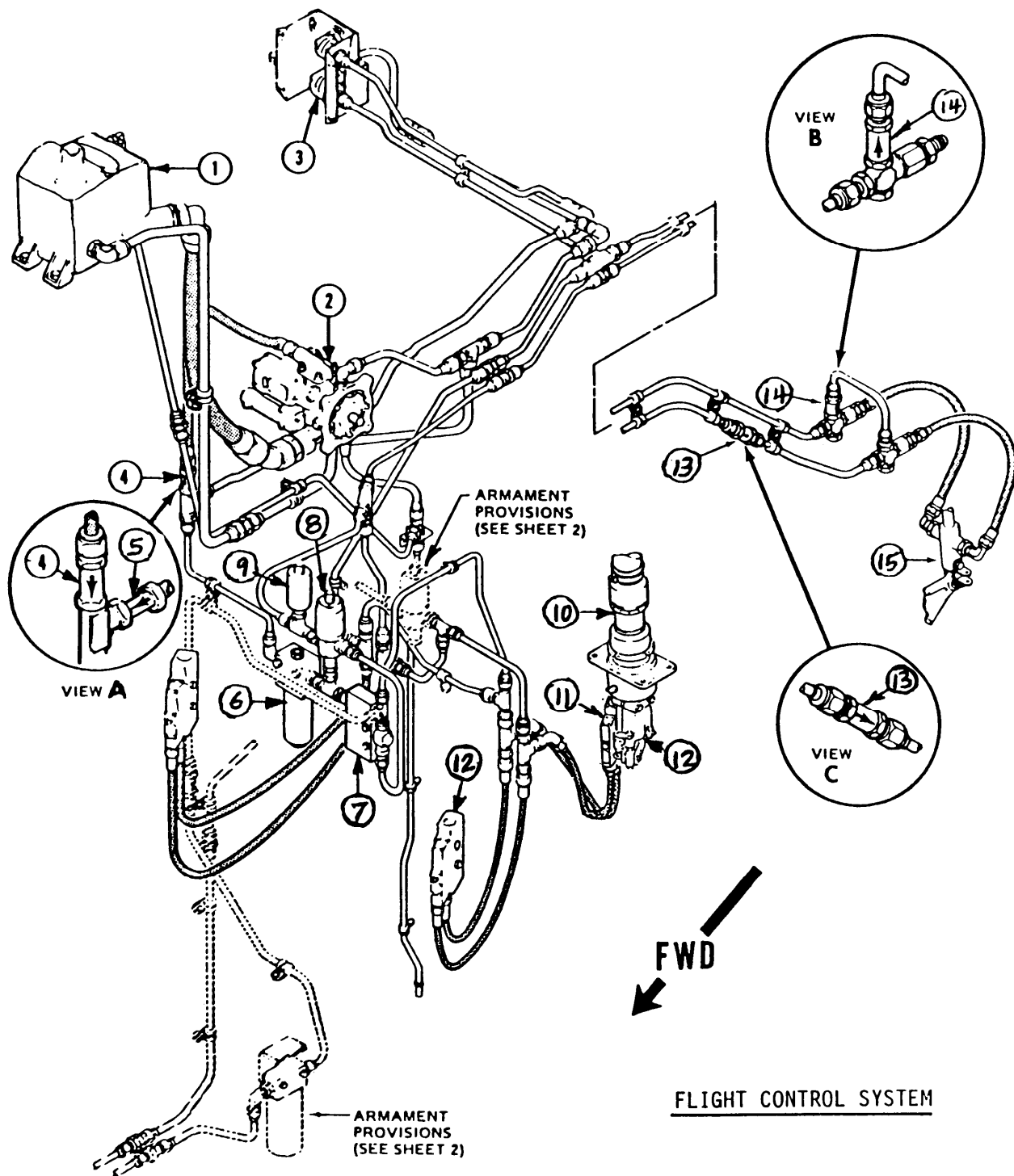
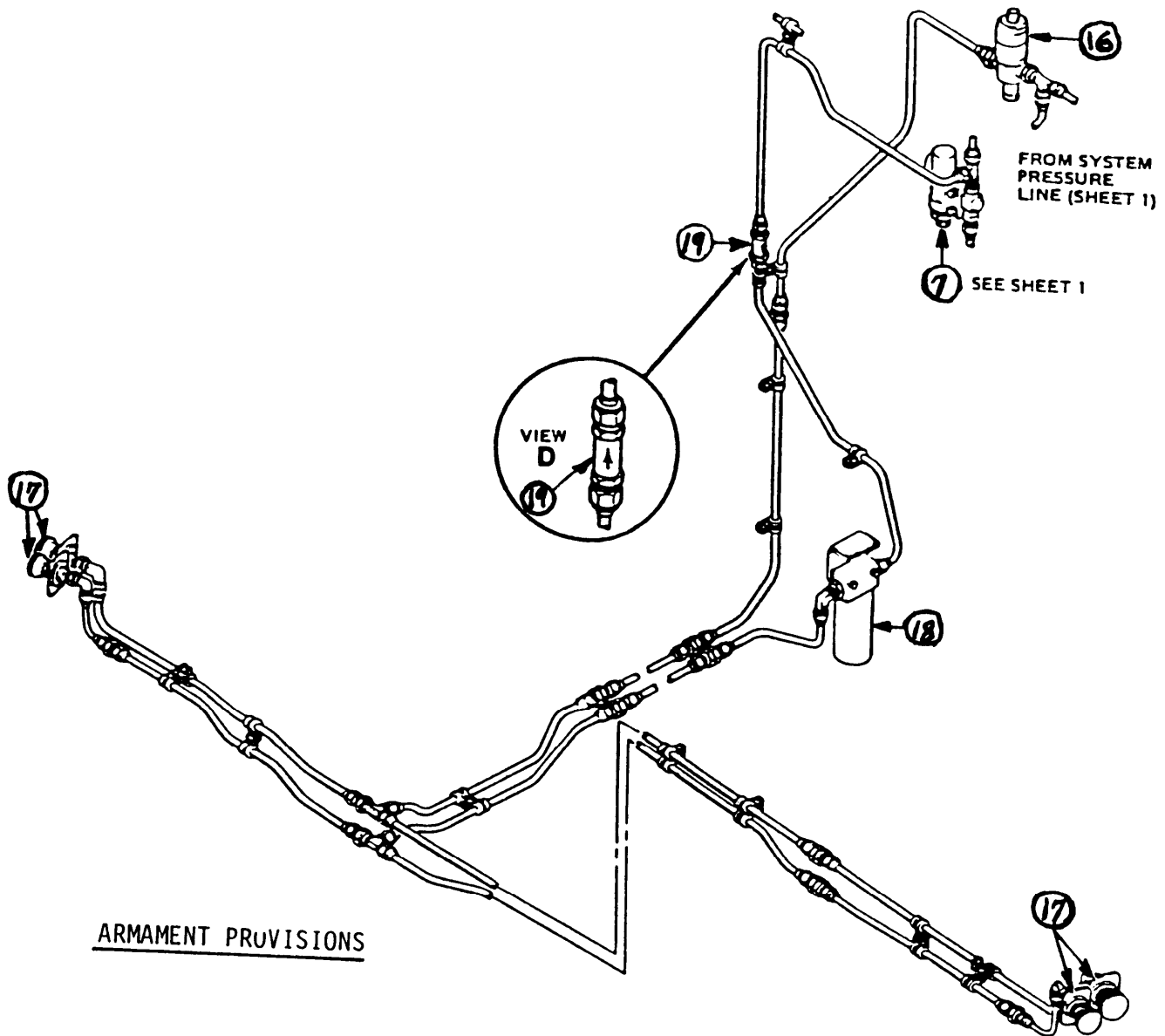

Figure 9-1. Hydraulic System (Sheet 1 of 2)



- | | |
|---------------------------------------|-------------------------------------|
| 1. Reservoir | 11. Servo Control Valve |
| 2. Pump | 12. Irreversible Valve |
| 3. Test Couplings | 13. Check Valve |
| 4. Check Valve | 14. Check Valve |
| 5. Check Valve | 15. Tail Rotor Cylinder Valve |
| 6. Filter | 16. Armament Shutoff Solenoid Valve |
| 7. Relief Valve | 17. Couplings for External Armament |
| 8. Solenoid Valve | 18. Armament Line Filter |
| 9. Pressure Switch | 19. Check Valve |
| 10. Power Cylinder
(typical 3 pcs) | |

Figure 9-1. Hydraulic System (Sheet 2 of 2)

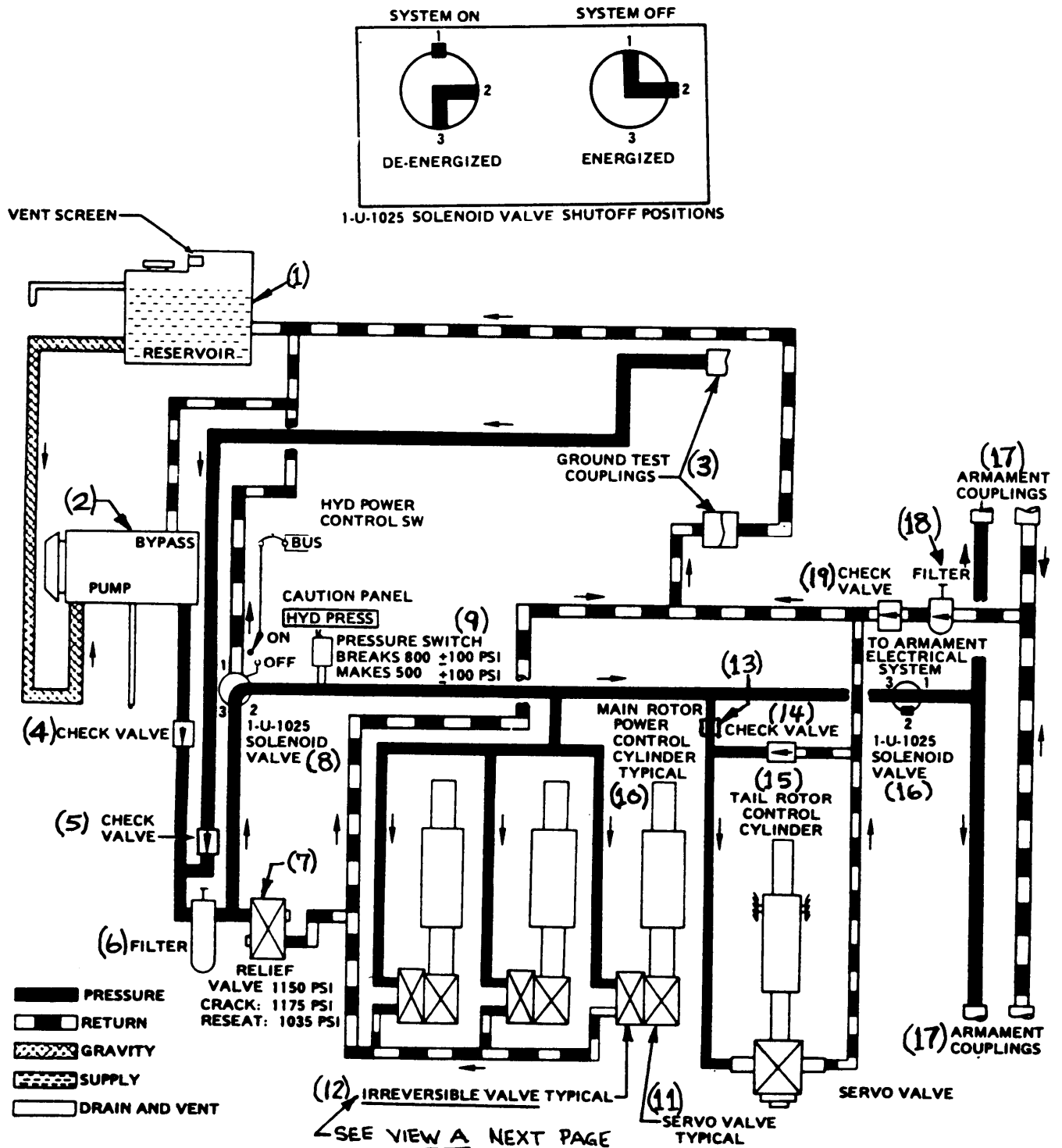

Figure 9-2. Hydraulic System Schematic (Gravity Feed) (Sheet 1 of 2)

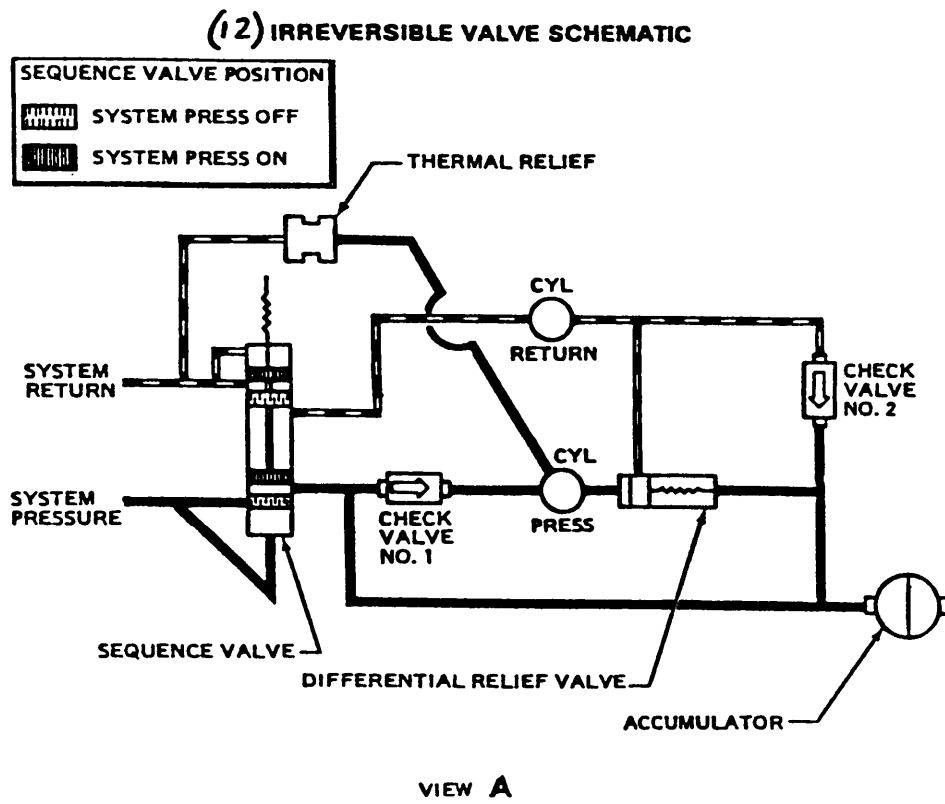

Figure 9-2. Hydraulic System Schematic (Gravity Feed) (Sheet 2 of 2)

Section II. HYDRAULIC RESERVOIR

9-4. GENERAL. The BDAR assessor must determine if the extent of leakage is acceptable and can be deferred or must be repaired. However, it should be noted that a leakage rate of one drop per second is approximately 0.38 pints per hour.

9-50 RESERVOIR, LEAKING HYDRAULICS FLUID.

LIMITATIONS: The repaired area, the hydraulic fluid level, and the pressure warning gages must be monitored more frequently.

PERSONNEL/TIME REQUIRED:

- 1 Soldier
- 45 Minutes

MATERIALS/TOOLS REQUIRED:

- . Adhesive Repair Kit (Item 5, App C)
- . Cleaning Solvent (items 1, 76, App C)
- Neoprene Rubber or Cloth (items 115, 117, App C)
- Tape (items 153, 156, App C)
- Wood Plug or Short Bolt
- . 5-Minute Epoxy (item 4, App C)

PROCEDURAL STEPS:

WARNING

Bring hydraulic system to zero pressure before making any repairs. Working pressure of 950 to 1000 psi can cause serious injury or death.

1. Drain hydraulic fluid from the reservoir. If necessary to stop all flow of fluid from damaged area, Figure 9-3.

2. Clean area around the crack or hole with solvent.

3. Seal opening with tape, short bolt, wooden plug or both, and clean again if necessary. Make sure all oil flow has stopped so adhesive will adhere.

4. Use an adhesive repair kit and cover the entire area. Repair kit (item 5, App C) is a premixed and saturated fiberglass cloth ready to use and dries in five minutes. If not available, use method below.

5. Mix epoxy adhesive and apply over the plug. Extend the adhesive 1 inch or more over the edge of plug or tape, and layer on approximately 1/8 inch thick.

6. Replenish the hydraulic oil supply and bleed air from the system per TM 55-1520-210-23.

7. Record BDAR action taken. When mission is complete, as soon as practical, repair the equipment/system using standard maintenance procedures.

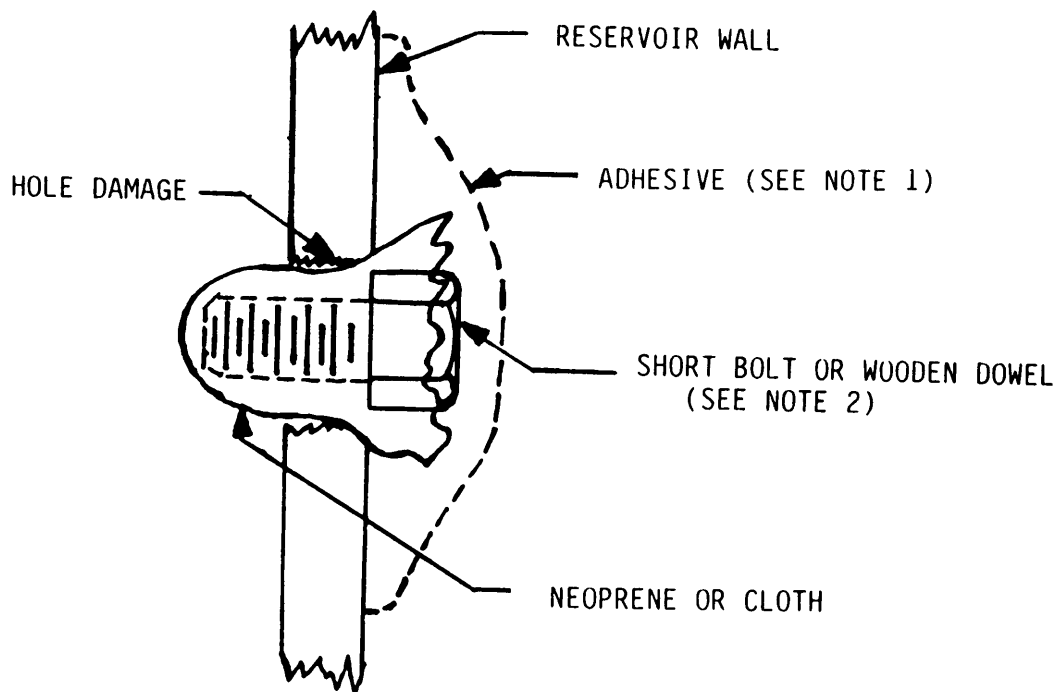

NOTES

1. CLEAN AREA TO RECEIVE ADHESIVE WITH SOLVENT.
2. MAKE SURE BOLT OR WOOD PLUG WILL NOT GO THROUGH THE RESERVOIR WALL.

Figure 9-3. Patch Repair for Leaks

Section III. HYDRAULIC FILTER

9-6. GENERAL. The BDAR assessor must determine if the extent of leakage is acceptable and can be deferred or must be repaired. However, it should be noted that a leakage rate of one drop per second is approximately 0.38 pints per hour.

9-70 HYDRAULIC FILTER, DAMAGE AND LEAKING.

OPTION 1: Filter (6, Fig 9-1) replaced with substitute filter (18, Fig 9-1)0

LIMITATIONS: The armament system will be downgraded.

PERSONNEL/TIME REQUIRED:

- 1 Soldier
- 1-1/2 Hours

MATERIALS/TOOLS REQUIRED: Helicopter must have armament (hydraulic) configuration.

PROCEDURAL STEPS:

1. Refer to Figure 9-1.
2. Evaluate damage and determine if leakage can be deferred. If not deferrable, continue repair.
3. Remove damaged filter (6) and remove armament filter (18).
4. Remove armament filter (18) and connect both ends of hydraulic tubes together with a union, or to jumper the removed filter (18). The tubes in armament system may also be plugged; however, this will disable the armament system.
5. Install filter (18) in place of filter (6). Both of the filters have identical thread connections.

6. Turn off armament shutoff solenoid valve (16) if the system is not needed. If it is needed, it will still operate if the removed filter (18) was jumpered.

7. If tubes were plugged, turn off armament valve (16).

8. Replenish any lost hydraulic fluid.

9. Record BDAR action taken. When mission is complete, as soon as practical, repair the equipment/system using standard maintenance procedures.

OPTION 2: Bypass damaged filter with hose.

LIMITATIONS: None.

PERSONNEL/TIME REQUIRED:

- 1 Soldier
- 1 Hour

MATERIALS/TOOLS REQUIRED:

- Bypass Hose (App B)
- Hand Tools (App B)
- Fluid Line Repair Kit (item, 4, Sec I, App B)

PROCEDURAL STEPS:

1. Remove damaged leaking filter (6).
2. Install fittings and bypass hose in place of filter, Figure 9-4.
3. Replenish hydraulic fluid lost.
4. Record BDAR action taken. When mission is complete, as soon as practical, repair the equipment/system using standard maintenance procedures.

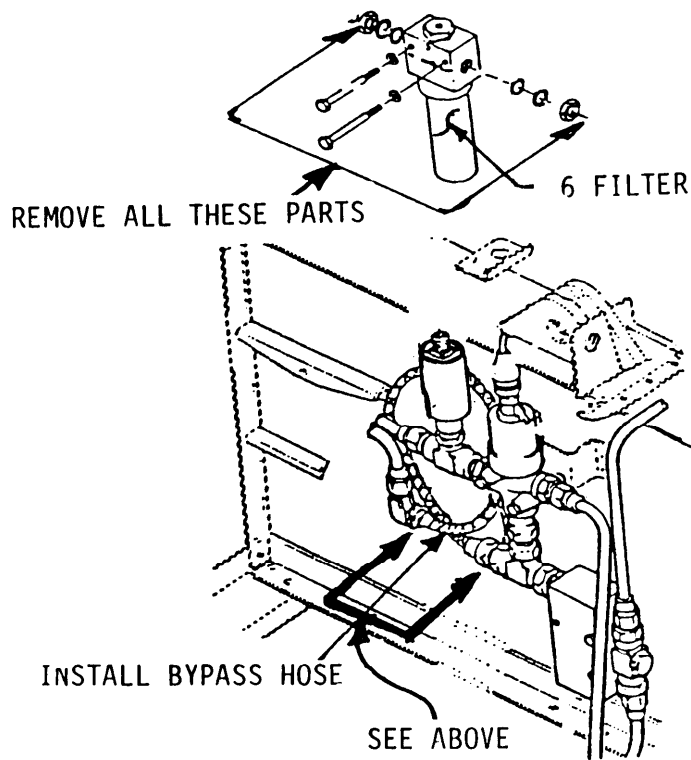

Figure 9-4. Filter Bypass Hose Installation

Section IV. RELIEF VALVE

9-8. GENERAL. The BDAR assessor must determine if the extent of leakage is acceptable and can be deferred or must be repaired. However, it should be noted that a leakage rate of one drop per second is approximately 0.38 pints per hour.

9-9. RELIEF VALVE, LEAKING HYDRAULIC FLUID. (Figure 9-5.)

GENERAL INFORMATION: None.

LIMITATIONS: Hydraulic system pressure will still be regulated at approximately 1000 psig by the pressure control built into the pump. Surging may be felt in control sticks. System will not be 100 percent operational. Be prepared to shut off hydraulic boost system and fly under emergency procedures.

PERSONNEL/TIME REQUIRED:

- 1 Soldier
- . 1 Hour

MATERIALS/TOOLS REQUIRED:

- Common Hand Tools (App B)
- Fluid Line Repair Kit (item 4, Sec I, App B)

PROCEDURAL STEPS:

1. Remove damaged relief valve (7, Fig 9-5).

2. Install a female thread coupling or plugged tee in place of banjo fitting on return line tubing.

3. Remove nipple from tee and install an MS plug with preformed packing.

4. Replenish hydraulic fluid lost.

5. Record BDAR action taken. When mission is complete, as soon as practical, repair the equipment/system using standard maintenance procedures.

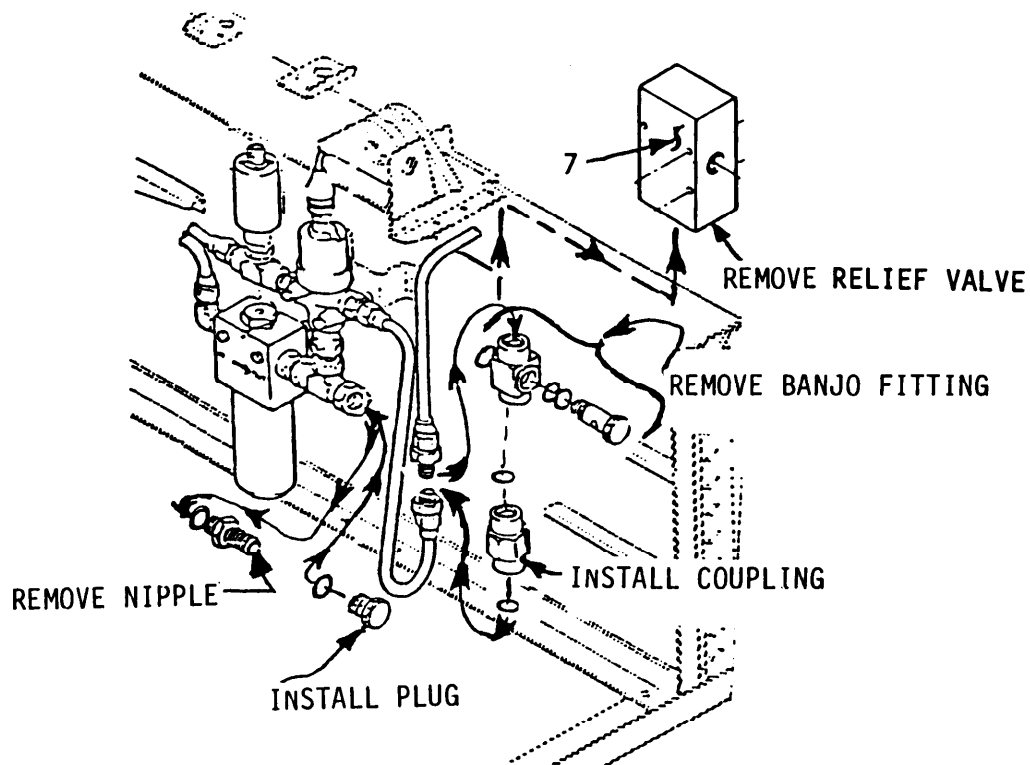

Figure 9-5. Relief Valve Removal

Section V. SOLENOID VALVE

9-10. GENERAL.

a. Two solenoid valves (8, 16, Fig 9-6) are used. One is located on forward side of cargo lift beam and the other (on helicopters with armament provisions) is located on aft side of cargo lift beam.

b. The BDAR assessor must determine if the extent of leakage is acceptable and can be deferred or must be repaired. However, it should be noted that a leakage rate of one drop per second is approximately 0.38 pints per hour.

9-110 SOLENOID VALVE, DAMAGED AND LEAKING. (Figure 9-6.)

OPTION 1: Replacement of damaged solenoid valve (8) with identical solenoid valve (16) found in the armament hydraulic system.

LIMITATIONS: Removal of armament solenoid valve (16) and reconnecting the hydraulic lines will provide function to armament system, but it cannot be turned off.

PERSONNEL/TIME REQUIRED:

- 1 Soldier
- 1-1/2 Hours

MATERIALS/TOOLS REQUIRED:

- Common Hand Tools (App B)
- Fluid Line Repair Kit (item 4, Sec I, App B)

PROCEDURAL STEPS:

j. Remove damaged main solenoid valve (8).

2. Remove armament solenoid valve (16).

3. Couple both ends of tube where solenoid (16) was removed using a nipple or a short piece of hose. This will leave armament hydraulic system "on line" available at all times, and it cannot be turned off.

4. To make armament system "off" all the time, plug both ends of hydraulic lines with "plugs or caps."

5. Install removed solenoid valve (16) in place of damaged and removed solenoid valve (8).

6. Replenish any lost hydraulic fluid.

7. Record BDAR action taken. When mission is complete, as soon as practical, repair the equipment/system using standard maintenance procedures.

OPTION 2: Remove solenoid valve (8) and install a bypass hose (Figure 9-7).

LIMITATIONS: Hydraulic pressure cannot be turned off.

PERSONNEL/TIME REQUIRED:

- 1 Soldier
- 1 Hour

MATERIALS/TOOLS REQUIRED:

- Bypass High Pressure Hose (App B)
- Hand Tools (App B)
- Fluid Line Repair Kit (item 4, Sec I, App B)

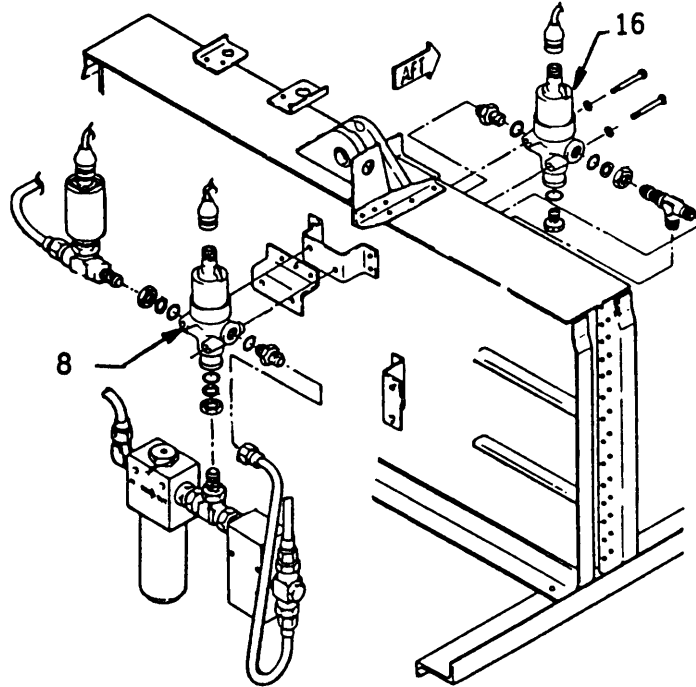

Figure 9-6. Solenoid Valve Replacement

PROCEDURAL STEPS:

1. Remove damaged solenoid valve (8) and all the hardware including the return line as shown in Figure 9-7.
2. Plug the banjo fitting with a plug and packing where the return line was removed.
3. Remove the locknuts from nipples in two places.
4. Install an 18 inch bypass hose.
5. Wrap and Insulate solenoid electrical connector that was removed from top of solenoid.
6. Check and replenish hydraulic oil supply
7. Record BDAR action taken. When mission is complete, as soon as practical, repair the equipment/system using standard maintenance procedures.

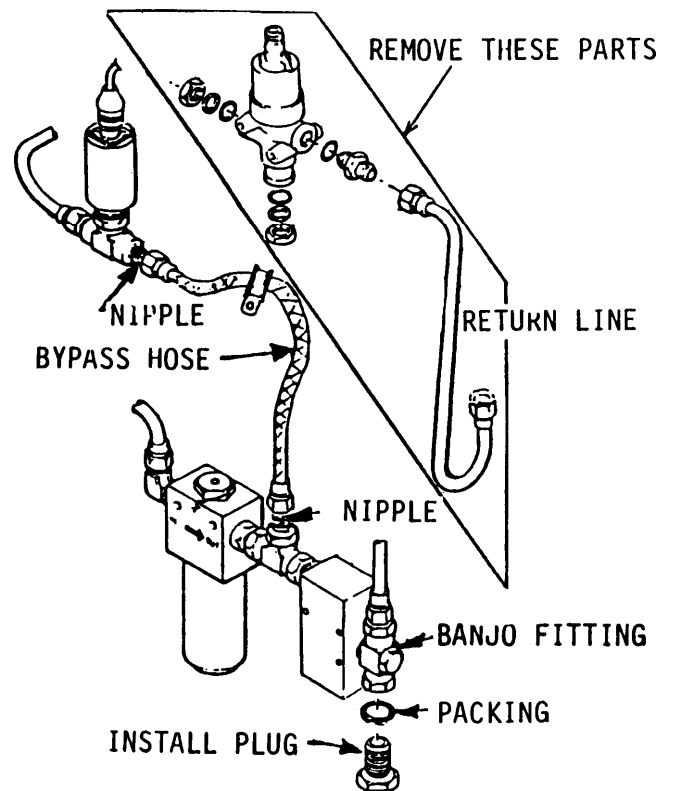

Figure 9-7. Bypass of Solenoid Valve

OPTION 3: Solenoid Valve (16) Bypass.
In case solenoid valve (16) is damaged and leaking, remove it and/or bypass it by coupling both tube ends that attach to it with a nipple or a short piece of

high pressure hose. The armament hydraulic system in this mode cannot be turned off. This fix is similar to bypass shown in Figure 9-7.

Section VI. PRESSURE SWITCH

9-12. GENERAL. Not applicable.

9-13. PRESSURE SWITCH, DAMAGED AND LEAKING.

LIMITATIONS: Low pressure of 500 psi or less will not be detected if pressure switch is removed to stop a leak.

PERSONNEL/TIME REQUIRED:

- 1 Soldier
- 30 Minutes

MATERIALS/TOOLS REQUIRED:

- Fluid Line Repair Kit (Item 4, Sec I, App B)
- Hand Tools (App B)

PROCEDURAL STEPS:

1. Remove damaged switch (9) from tee fitting.
2. Install an AN 814 plug in outlet of tee from where switch was removed.
3. Wrap and stow electrical connector with electrical tape.
4. Place adhesive tape over the hydraulic caution panel segment and mark it as disconnected.
5. Record BDAR action taken. When mission is complete, as soon as practical, repair the equipment/system using standard maintenance procedures.

Section VII. CHECK VALVES

9-14. GENERAL. The BDAR assessor must determine if the extent of leakage is acceptable and can be deferred or must be repaired. However, it should be noted that a leakage rate of one drop per second is approximately 0.38 pints per hour.

9-150 CHECK VALVES, LEAKING. (Figure 9-1.)

LIMITATIONS: Check valves (4, 13, 14) are critical to proper operations of hydraulic controls, and they are to be replaced if damaged. Check valves (5, 9) are not critical and can be removed if leaking (damaged), or to use as a substitute for (4, 13, 14).

PERSONNEL/TIME REQUIRED:

- 1 Soldier
- 2 Hours

MATERIALS/TOOLS REQUIRED:

- Fluid Line Repair Kit (Item 4, Sec I, App B)
- Hand Tools (App B)

PROCEDURAL STEPS:

1. Remove the damaged check valve (4, 13, 14).
2. Remove a noncritical check valve. Preferably armament check valve (19). If valve (19) is not in aircraft, remove ground test coupling check valve (5).

3. Cap or plug, or bypass line tubes or fittings where noncritical check valve (5) or (19) was removed.
4. Check valves (5, 19) are MS-6 thread size. If substituting in place of check valve (13, 14), a reducing fitting will be required since these valves are MS-4 thread size, Figure 9-8.

CAUTION

Ensure that directional flow arrow is pointing in right direction prior to installation.

5. Line tubing will require a small amount of reshaping to accommodate substitute valve.
6. Replenish any lost hydraulic fluid.
7. Record BDAR action taken. When mission is complete, as soon as practical, repair the equipment/system using standard maintenance procedures.

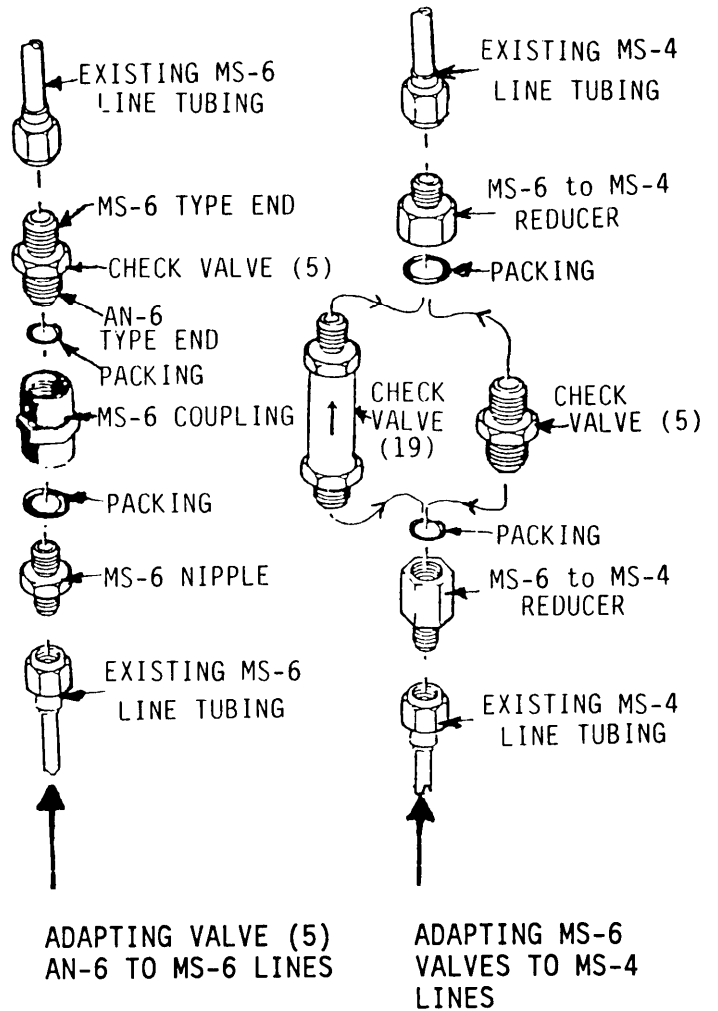

Figure 9-8. Check Valve Substitution

Section VIII. ARMAMENT HYDRAULIC SYSTEM

9-16. GENERAL.

a. On helicopters with provisions for externally mounted armament, pressure is supplied to a normally-open solenoid valve (16) which is controlled by a switch on an armament control panel. When the valve is open, hydraulic fluid is supplied to the external couplings on each side of the helicopter. When external hydraulic equipment is connected, fluid used to operate the equipment is returned through a filter and check valve to the hydraulic reservoir.

b. Any damage which causes hydraulic leaks in armament system can expediently be controlled by turning off the system and plugging line.

9-17. ARMAMENT HYDRAULIC SYSTEM, LEAKING.

LIMITATIONS: No armament hydraulic system.

PERSONNEL/TIME REQUIRED:

- 1 Soldier
- 30 Minutes

MATERIALS/TOOLS REQUIRED:

- **Common Tools, MS-6 Plug (item 4, App B)**
- Fluid Line Repair Kit (item 4, Sec I, App B)

PROCEDURAL STEPS:

1. Turn off system pressure with armament shutoff solenoid valve (16, Fig 9-1)
2. Remove check valve (19) and plug line in both directions with MS-6 plugs and o-rings.
3. Replenish any lost fluid.
4. Record BDAR action taken. When mission is complete, as soon as practical, repair the equipment/system using standard maintenance procedures.

Section IX. HYDRAULIC HIGH PRESSURE HOSES

9-18. GENERAL. No BDAR fix. Turn off system.

Section X. HYDRAULIC HIGH PRESSURE METAL TUBING

9-19. GENERAL. The following BDAR fixes are designed to be quickly and easily applied and should be used if no standard repair/replacement part is available.

9-20. METAL TUBE LEAKING/DAMAGED.

OPTION 1: Replace metal tube.

LIMITATIONS: Temporary.

PERSONNEL/TIME REQUIRED:

- 1 Soldier
- 1/2 Hour

MATERIALS/TOOLS REQUIRED:

- Wrenches
- Hose Clamps
- Fluid Line Repair Kit (item 4, Sec I, App B)

PROCEDURAL STEPS:

1. Disconnect metal tube from fitting.
2. Move metal tube free of fittings.
3. Connect together as many flex hoses to equal to the length of the damaged line.

4. Install flex hose in the place of the metal tube.

5. Record BDAR action taken. When mission is complete, as soon as practical, repair the equipment/system using standard maintenance procedures.

OPTION 2: Repair with hose splice.

LIMITATIONS: None.

PERSONNEL/TIME REQUIRED:

- 1 Soldier
- 1 Hour

MATERIALS/TOOLS REQUIRED:

- Hacksaw (item 94, Sec II, App B)
- Hose Clamp (items 67-72, App C)
- Rubber Hose (item 4, App B)
- Adhesive (items 4 or 10, App C)

PROCEDURAL STEPS:

1. Remove damaged hose section by cutting with hacksaw. Deburr ends of tube.
2. Cut a piece of high pressure hose to bridge the removed section plus extra length for clamping three hose clamps on each end.
3. Attach hose and clamps to tubing in similar fashion as shown in Figure 9-9.
4. Five minute epoxy adhesive may be used between tube and hose. Use care not to contaminate inside of hydraulic lines with adhesive.
5. Replenish the hydraulic oil supply.
6. Record BDAR action taken. When mission is complete, as soon as practical, repair the equipment/system using standard maintenance procedures.

OPTION 3: Pin hole leaks for metal tubes.

LIMITATIONS: None.

PERSONNEL/TIME REQUIRED:

- 1 Soldier
- 30 Minutes

MATERIALS/TOOLS REQUIRED:

- Clamp, Hose (items 67-72, App C)
- Rubber Sheet 1/8 in. min. thickness (item 117, App C)

PROCEDURAL STEPS:

1. Pin hole leaks 1/8 diameter or less.
2. Place a piece of hard rubber sheet or a piece of rubber hose over the hole, and place hose clamp directly over the rubber. Rubber sheet should extend past both outside edges of clamp band.
3. Tighten hose clamp.
4. Record BDAR action taken. When mission is complete, as soon as practical, repair the equipment/system using standard maintenance procedures.

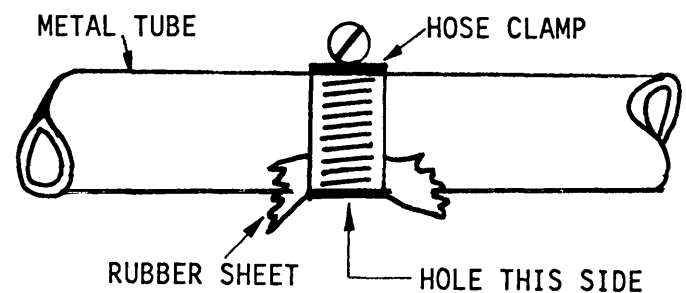

Figure 9-9. Rubber Pressure Patch

Section XI. BLEED AIR SYSTEM TUBES AND HOSES

9-21. GENERAL. The most critical component of the pneumatic bleed air system is the engine and transmission oil cooler fan. If damaged, every possible effort should be made to restore operation of this portion of the system to prevent engine and transmission oil overheating. Certain UH-1H/Vmodel helicopters may still have pneumatic fuel boost pumps installed on the lower fuel cells. If aircraft is in this configuration, effort should also be directed toward repairing pneumatic line damage routed to pumps. The BDAR fixes contained in this section apply only to repair of the bleed air line to the oil cooler fan and to the fuel pump.

9-22. BLEED AIR LINE LEAKING-PLUG OR ISOLATE.

GENERAL INFORMATION: None.

LIMITATIONS: Except for the oil cooler fan line and pneumatic boost pump lines. All bleed air lines can be plugged, removed, or isolated without downgrading helicopter flight status.

PERSONNEL/TIME REQUIRED:

- 1 Soldier
- 30 Minutes

MATERIALS/TOOLS REQUIRED:

- Common Hand Tools (App B)
- Fluid Line Repair Kit (item 4, Sec I, App B)

PROCEDURAL STEPS:

1. Determine if bleed air line or component it supplies can be isolated and removed. Remove damaged hose.
2. Install appropriate plug or cap on line.
3. Record BDAR action taken. When mission is complete, as soon as practical, repair the equipment/system using standard maintenance procedures.

9-23. BLEED (FLEX TUBE) AIR LINE 3/4 AND 1 INCH TO OIL COOLER FAN LEAKING.

OPTION 1: Splice repair-metal tube splice.

LIMITATIONS: All repairs made to the bleed air system must utilize materials and parts capable of withstanding the approximate 550 degree heated bleed air temperature.

PERSONNEL/TIME REQUIRED:

- 1 Soldier
- 1 Hour

MATERIALS/TOOLS REQUIRED:

- Common Hand Tools (hacksaw, pliers, screwdriver) (App B)
- Hose Clamps (item 67-72, App C)
- Metal Tube 3/4 or 1 Inch OD Aluminum or Steel (low pressure) Tubing
- Epoxy Adhesive (items 3 or 4, App C)

PROCEDURAL STEPS:

1. Remove damaged hose to facilitate repair if possible.
2. Wrap wire braid cover with several layers of masking tape to facilitate cutting, and cut with a fine tooth blade hacksaw. Remove damaged section.

WARNING

Woven wire braid cover of hose will puncture human skin. Exercise care in handling. Wear protective gloves.

3. Push the woven wire braid back from cut line approximately 2 inches, and hold in place by masking tape.
4. Using a hacksaw, cut one or two slots in each end of flexible hose tube as shown. Cut slots 1-1/2 inches long. These slots may be left optional and instead slot the splice metal tube.

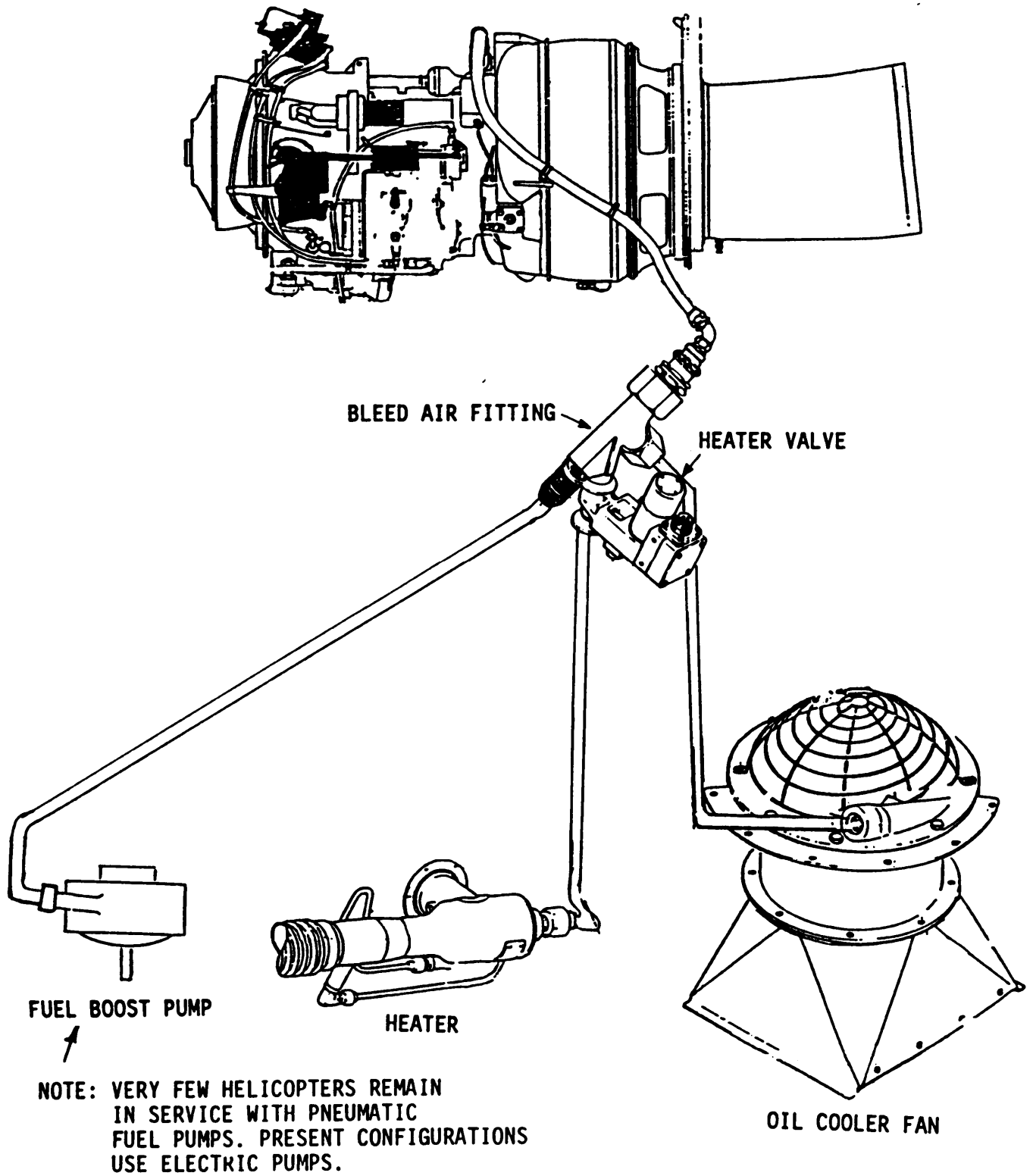

Figure 9-10. UH-1 Bleed Air System

5. Cut a length of metal tubing with an outside diameter (3/4 or 1 in.) to fit inside diameter of the flexible metal hose. Length as needed to replace removed section plus 4 inches more.

6. Insert repair tube splice into both ends of metal flex hose as shown in Figure 9-11, and clamp in place with four hose clamps.

7. If time permits, and adhesive epoxy can be applied to joint. Clean area with solvent, cover the end joint, and the hacksaw cut slots with a five minute epoxy. Wait five minutes for adhesive to cure before operating system.

8. Record BDAR action taken. When mission is complete, as soon as practical, repair the equipment/system using standard maintenance procedures.

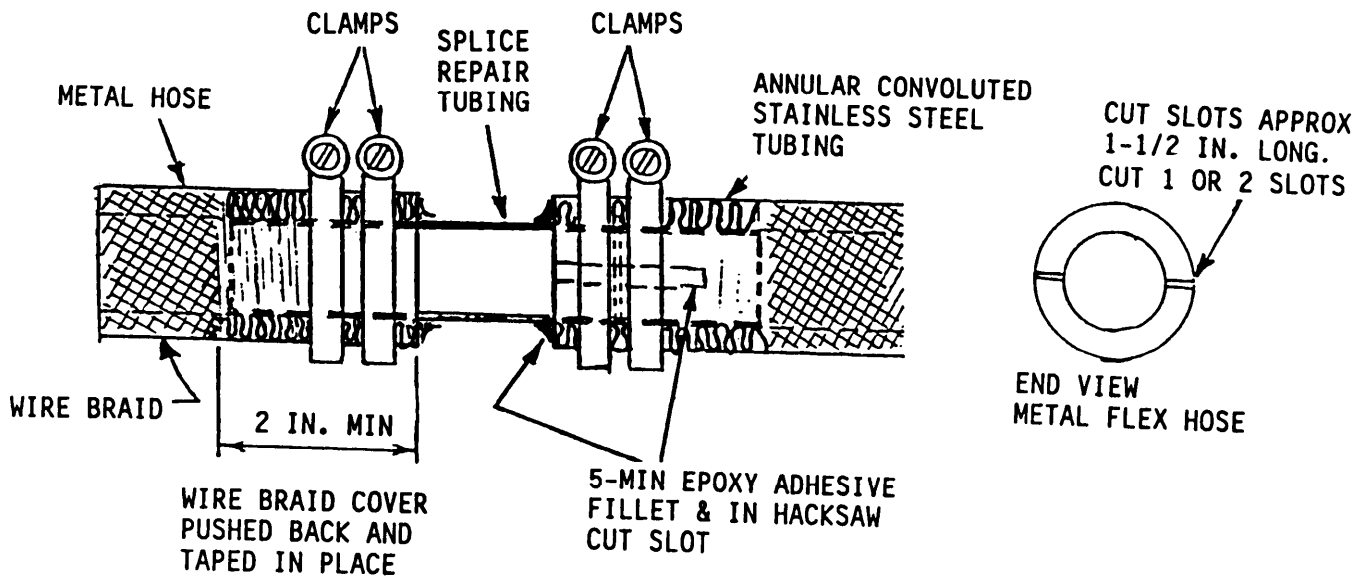

Figure 9-11. Bleed Air Hose Repair

OPTION 2: Splice repair-sheet metal wrap, Figure 9-12.

LIMITATIONS: None.

PERSONNEL/TIME REQUIRED:

- .2 Soldiers
- 1-1/2 Hours

MATERIALS/TOOLS REQUIRED:

- Epoxy Adhesive (item 3 or 4, App C)
- Common Hand Tools (App B)
- Hose Clamps (items 37-41, App C)
- Safety Wire (lockwire) (items 73-75, App C)
- Tape (item 153, App C)

PROCEDURAL STEPS:

1. If damage has completely cut through tube, use a hacksaw to remove damaged section as shown in Figure 9-12.
2. Measure and cut a piece of sheet metal, allowing for 1-1/2 to 2 Inch overlap of tubing ends.
3. Apply sealant adhesive to both ends of tubing.
4. Wrap sheet metal tightly around and secure with safety wire as shown in Figure 9-12C.

NOTE

Sheet metal serves as a splice to conduct main airstream. Firesleeve or tape provides a (heat proof) seal to prevent excessive air leakage.

5. Measure and cut a piece of red firesleeve, allowing for 3 inch overlap of tubing end and sheet metal as shown in Figure 9-12D. If firesleeve material is not available, wrap splice area with aluminum tape.
6. Wrap firesleeve or tape tightly around sheet metal splice and tube. Hold firesleeve tight and secure with gear type hose clamps as shown in Figure 9-12D.

7. Record BDAR action taken. When mission is complete, as soon as practical, repair the equipment/system using standard maintenance procedures.

OPTION 3: Patch repair-sheet metal patch and clamps flexible metal hose, Figure 9-13.

LIMITATIONS: None.

PERSONNEL/TIME REQUIRED:

- .1 Soldier
- . 1 Hour

MATERIALS/TOOLS REQUIRED:

- . Epoxy Adhesive (items 3-8, App C)
- Common Hand Tools (App B)
- Hose Clamp (items 37-41, App C)
- Safety Wire (lockwire) (items 73-75, App C)
- . Sheet Metal 0.016 Stainless Steel or Equivalent (item 141, App C)
- . Tape, Aluminum (item 153, App C)

PROCEDURAL STEPS:

1. Cut the stainless steel braid outer cover with metal snips and move out of the damaged area. Use tape to secure the cut braid cover out of the way. Be careful not to damage the flexible hose any more.

2* Hammer or file damaged area to allow patch to fit flush with tube surface. Remove metal filings from tube to prevent clogging or downstream air nozzles.

3. Cut patch from sheet metal to cover hole or other damage. Patch should extend approximately 1 inch from the edge of the hole at all points if possible.

4. Clean the area with solvent and apply epoxy sealant around the hole area to be covered by the patch.

5. Place sheet metal patch in position. Make sure patch fits the contour of tube.

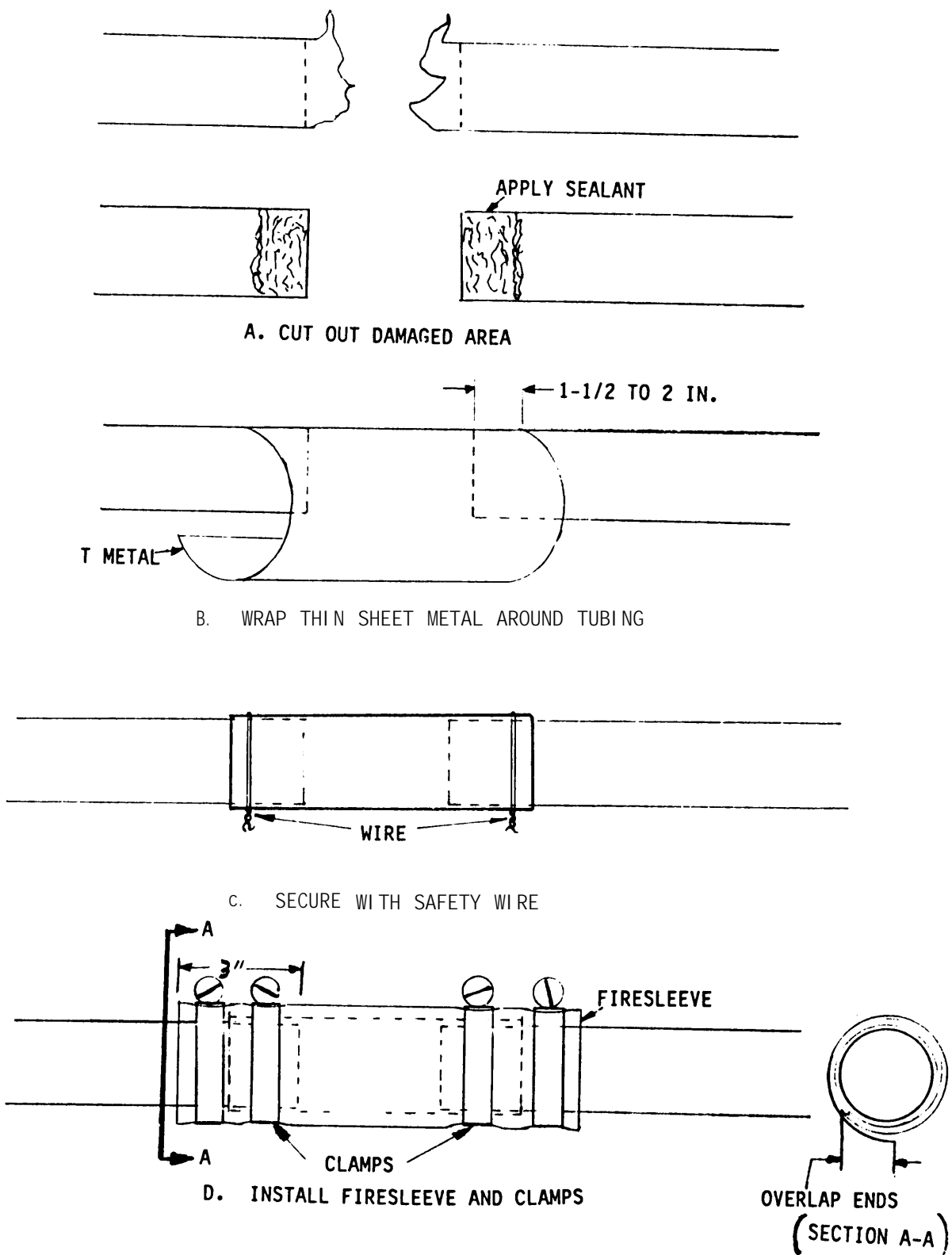

Figure 9-12. Rigid Bleed Air Tube Splice Repair

60 Wrap aluminum tape around the patch repair. Tape should cover at least 2 inches beyond the edge of repair.

7. Secure metal patch in place using hose clamp. (If hose clamps are not available, secure in place with safety wire.)

8. Record BDAR action taken. When mission is complete, as soon as practical, repair the equipment/system using standard maintenance procedures.

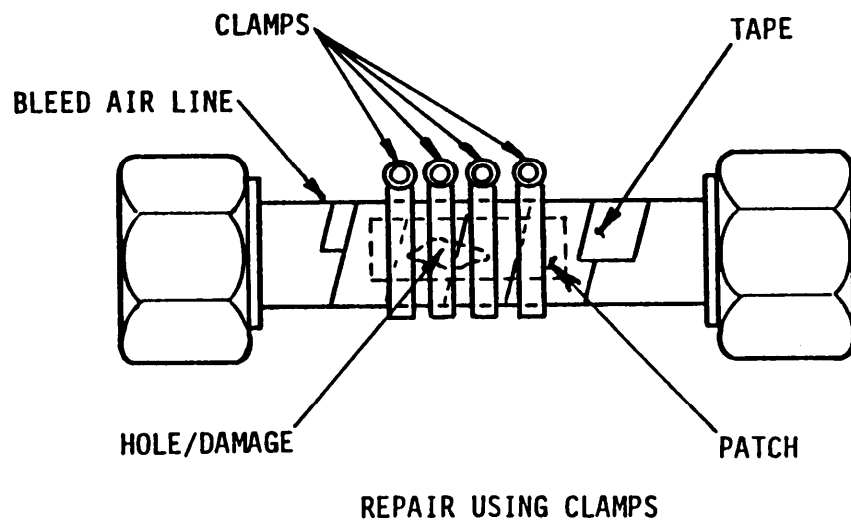

Figure 9-13. Rigid Bleed Air Tube Patch Repair

OPTION 4: Patch repair using adhesive patch kit.

LIMITATIONS: None.

PERSONNEL/TIME REQUIRED:

- 1 Soldier
- 30 Minutes

MATERIALS/TOOLS REQUIRED:

- Adhesive Repair Kit (item 5, App C)
- Solvent (items 1, 76, App C)
- Tape (item 153, App C)

PROCEDURAL STEPS:

1. Cut the stainless steel braid outer cover with tin snip, and move it out of

the damaged area. Use tape to secure the cut braid out of the way. Be careful not to damage the flexible hose any further.

2. Remove burr, loose metal, and straighten metal tube as close to original contour as possible.

3. Wrap damaged area with three to four layers of aluminum tape.

4. Using adhesive repair kit, patch the area with two or three layers of patch material. Extend the edge of patch 1-1/2 inches past the edge of the aluminum tape all the way around.

Section XII. BLEED AIR FITTING

9-24. BLEED AIR FITTINGS, DAMAGED.

GENERAL INFORMATION: The bleed air fitting can be replaced (bypassed) with a TEE or ELBOW fitting, Figure 9-14.

LIMITATION: Use of a fitting (tee or elbow) to reconnect air supply to oil cooler fan **will isolate and** remove fuel boost pump and the heater from service function.

PERSONNEL/TIME REQUIRED:

- 1 Soldier
- 2 Hours

MATERIALS/TOOLS REQUIRED:

- Common Hand Tools (App B)
- Fluid Line Repair Kit (item 4, App B)
 - Plug
 - Reducer Fittings
 - 90° Elbow or Tee Fitting

PROCEDURAL STEPS:

1. Remove damaged parts.

2* Install reducer fitting in 90° elbow or tee as required. If a tee is used, install plug on one end.

3. Install 90° elbow into bleed air lines.

4. Record BDAR action taken. When mission is complete, as soon as practical, repair the equipment/system using standard maintenance procedures.

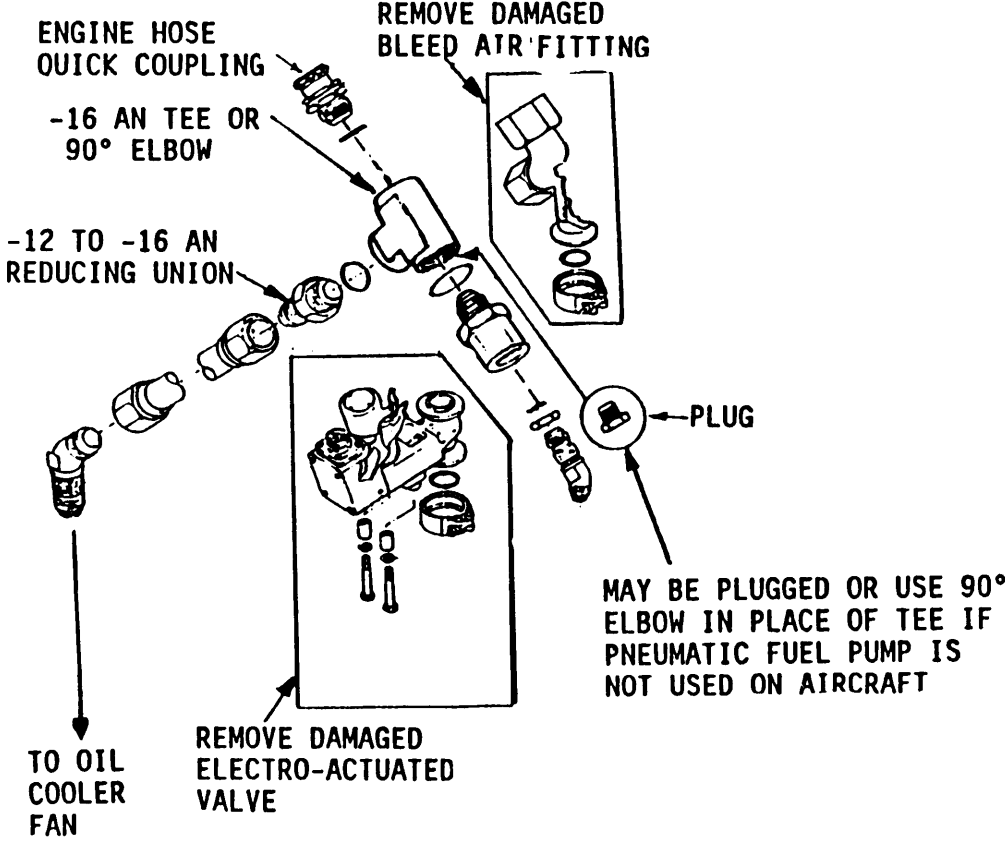

Figure 9-14. Bypassing Damaged Bleed Air Fittings

CHAPTER 10

INSTRUMENTS

**BDAR FIXES SHALL BE USED ONLY IN COMBAT OR FOR TRAINING
AT THE DISCRETION OF THE COMMANDER.
(AUTHORIZED TRAINING FIXES ARE LISTED IN APPENDIX E.)
IN EITHER CASE, DAMAGES SHALL BE REPAIRED BY STANDARD
PROCEDURES AS SOON AS PRACTICABLE.**

Section I. INTRODUCTION

10-1* SCOPE.

a. Battle damage instrument repair is beyond the scope of this chapter. Replacement will normally be at AVUM or AVIM level.

b. Deferred repairs will be emphasis and will allow helicopters to remain operational with varying degrees of limitations/capabilities, Table 10-2. This table contains information that will guide and help determine what instruments are necessary for minimum requirements.

c. Driving input systems for instruments will be either electrical power circuits and pneumatic plumbing circuits. For repair of these systems, see paragraph 10-3.

10-2. ASSESSMENT PROCEDURES. See Table 10-1, Instruments Assessment.

10-3. REPAIR PROCEDURE INDEX.

PARA.

Oil Pressure Indicator or Transmitter, Damaged/Bad Read.	10-6.
--	-------

Pitot Plenum, Dama.	10-8
Static Manifold, Damage	10-9
Instrument Replacement	TM 55-1520- 210-23
Electrical Circuits.	Chpt 11

Section II. ASSESSMENT AND REPAIR PLANNING

10-4. FUNCTIONAL LIST AND ASSIGNMENT OF FLIGHT ESSENTIAL INSTRUMENTS.

a. Flight Essential Instruments. All instruments in the pilots panel are essential for safe flight. Under combat conditions, replacement instruments may not always be available and missions may have to be flown without the aid of operative instruments.

b. Copilot panel can be used as source of replacement instruments for pilot's panel. When instruments are replaced, make sure the range markings are correct.

c. Malfunctioning instruments should not be removed unless replacement instruments are available.

d. When a good instrument is removed from the copilot's panel for installation in the pilot's panel, the malfunctioning instrument should be placed in the copilot's panel and marked "bad" on the face.

e. When the cover glass of an instrument is broken and a replacement instrument is not available, remove all loose glass shards from the instrument and leave it in the panel.

Table 10-1. Instruments Assessment

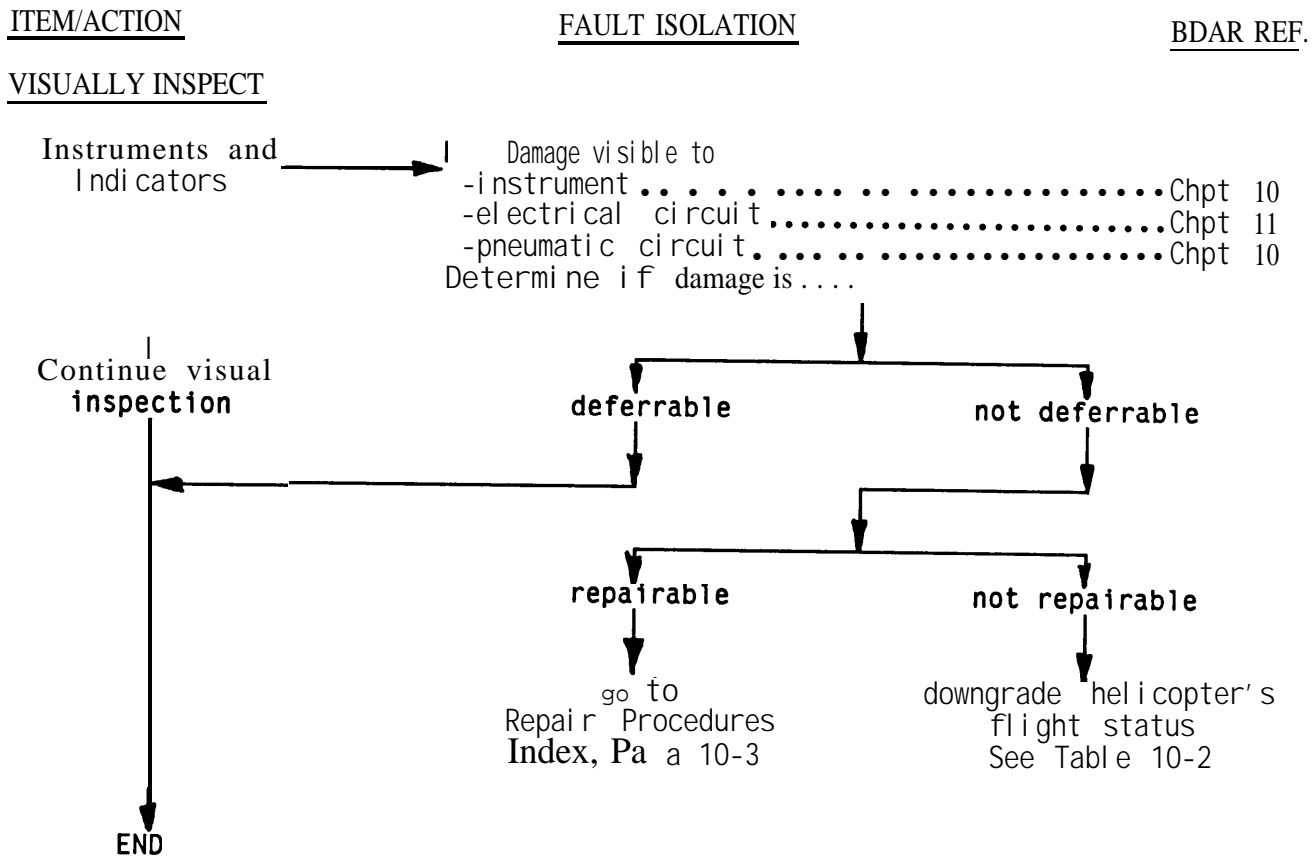

Table 10-2. System Evaluation

INSTRUMENT OUT OF COMMISSION	REQUIRED FOR EMERGENCY OR SELF-RECOVERY	CONDITIONAL REQUIREMENTS CROSS-REFERENCE TO OTHER INSTRUMENTS/INDICATORS
1. Torquemeter Indicator	No	Must have functional indicators 2 and 4 as a backup.
2. Exhaust Gas Temperature Indicator	No	Must have functional indicators 1, 3, and 4 as a backup.
3. Dual Tachometer Indicator		
Engine	No	If rotor portion of tachometer is working, monitor rotor rpm.
Rotor	No	If engine portion of tachometer is working, monitor engine rpm.
4. Gas Producer Tachometer Indicator	No	Must have at least item 1 or 3 fully functional.
5. Engine Oil Temperature Indicator	No	If transmission oil temperature indicator reads normal, check function of the engine oil temperature indicator by exchanging the leads of both indicators.
6. Engine Oil Pressure Indicator	No	Caution panel "engine oil press" must be fully functional. Check and test circuit by exchanging leads with XMSN oil pressure indicator.
7. Fuel Pressure Indicator	No	Main engine fuel pump must be fully functional and helicopter's ceiling limited to 4600 pressure altitude.
8. Fuel Quantity Indicator	No	Monitor caution panel "20 minutes" warning light.
90. Transmission Oil Pressure Indicator	No	Monitor caution panel "transmission low oil pressure" warning light. If engine oil pressure indicator is functional, check indicator by exchanging lead of both indicators.

Section III. ENGINE OIL PRESSURE INDICATOR AND TRANSMITTER

10-50 GENERAL. The following procedure explains how to **check** the system if a low pressure reading is being caused by a damaged oil pressure indicator, transmitter or electrical circuit. Battle damage to the system can be easily located by visual inspection and the following assessment procedure.

10-6, OIL PRESSURE INDICATOR OR TRANSMITTER, DAMAGED/BAD READING.

GENERAL: Low oil pressure on Indicator could be caused by tripping of electrical circuit breaker. The breaker in turn could be tripped by a damaged electrical circuit. Both the circuit breaker and circuit should be checked for battle damage failure.

LIMITATIONS: As long as oil pressure/circulation is present, the engine oil pressure system indicators can be non-functional.

PERSONNEL/TIME REQUIRED:

- 1 Soldier
- 1/4 Hour

MATERIALS/TOOLS REQUIRED:

- Volt-Ohm Meter (item 229, App B)

PROCEDURAL STEPS:

1. Visually check the oil pressure transmitter and indicator for damage, Figure 10-1. **If damaged** but no oil leaks are present, check for function by continuing below.
2. **If** the engine oil pressure reading is bad and the transmission oil pressure is good, then remove both the engine and

the transmission oil pressure indicators from the instrument panel. Disconnect the electrical plugs in back and switch the electrical plugs on the two indicators. The engine oil pressure will now be read on the transmission oil pressure indicator.

3. **If** the engine oil pressure reading is bad on the transmission indicator, then the transmitter or the wiring coming from it is bad and will need replacement. Continue assessment to determine the loss of oil pressure.

4. **If** engine oil pressure indicates good on the transmission indicator, then engine is fully mission capable and the engine oil pressure indicator is bad. Replace the indicator at convenient time.

- 50 **If** low pressure warning light on warning panel does not come on, then engine oil pressure is above 25 psi. **If** the low pressure switch is damaged, check to see if it is functional by checking with the light test switch and the circuit breaker. This only checks the caution panel light bulb. To check system wiring, remove cannon plug from the pressure switch. Use volt-ohmmeter (VOM) between the two pins in the cannon plug. Check for 28 VDC. This will indicate wiring is continuous.

6. Record BDAR action taken. When mission is complete, as soon as practical, repair the equipment/system using standard maintenance procedures.

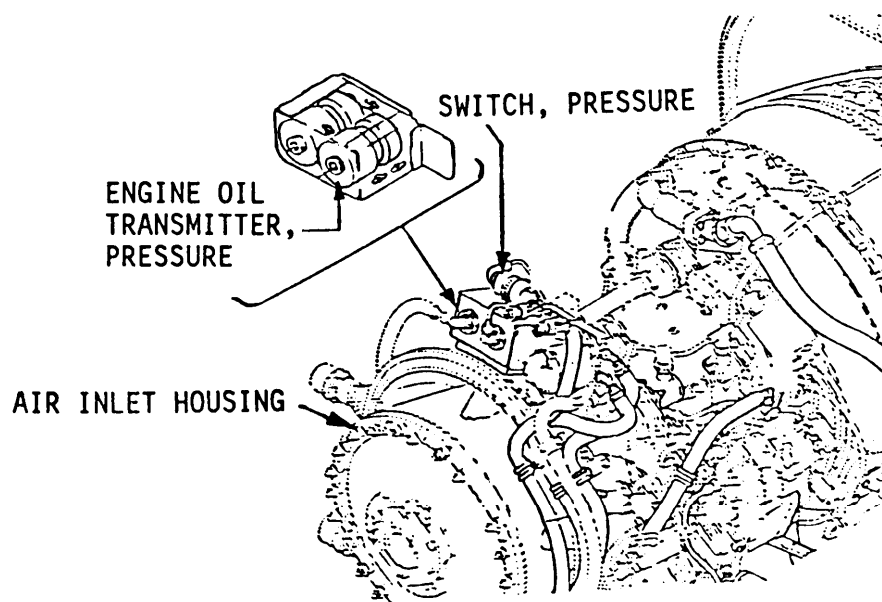

Figure 10-1. Oil Pressure Transmitter

Section IV. PITOT/STATIC SYSTEM

10-70 PITOT/STATIC SYSTEM.

The fixes shown are relatively simple and expedient and can be used to restore lost function. In extreme emergency, repairs are to be deferred and repaired later by replacing damaged components.

10-8. PITOT PLENUM, DAMAGED.

See Figure 10-2.

OPTION 1: Patch with aluminum tape.

LIMITATIONS: Temporary repair-reinspect every 100 hours.

PERSONNEL/TIME REQUIRED:

- 1 Soldier
- 1 Hour

MATERIALS/TOOLS REQUIRED:

- **Common Hand Tools**
- Aluminum Tape (item 153, App C)

PROCEDURAL STEPS:

1. Ensure enough of the plenum remains to allow an airtight seal with the tape.
2. Remove the plenum.
3. Wrap tape around plenum overlapping the edges to ensure an airtight seal.
4. Reinstall plenum.
5. Record BDAR action taken. When mission is complete, as soon as practical, repair the equipment/system using standard maintenance procedures.

OPTION 2: Remove plenum and byPass.

LIMITATIONS: None.

NOTE

The plenum helps dampen pressure surges. Some indicator needle fluctuation may occur due to loss of dampening action when the plenum is removed or bypassed.

PERSONNEL/TIME REQUIRED:

- 1 Soldier
- 1 Hour

MATERIALS/TOOLS REQUIRED:

- Common Hand Tools (App B)
- Fluid Line Repair Kit (item 4, Sec I, App B)

PROCEDURAL STEPS:

1. Remove damaged plenum.
2. Install bypass hose using unions, or cut existing AN flare fittings from ends of existing aircraft tubing and install a bypass hose using hose clamps.
3. Record BDAR action taken. When mission is complete, as soon as practical, repair the equipment/system using standard maintenance procedures.

10-9. STATIC MANIFOLD, DAMAGED.

LIMITATIONS: Defer repair.

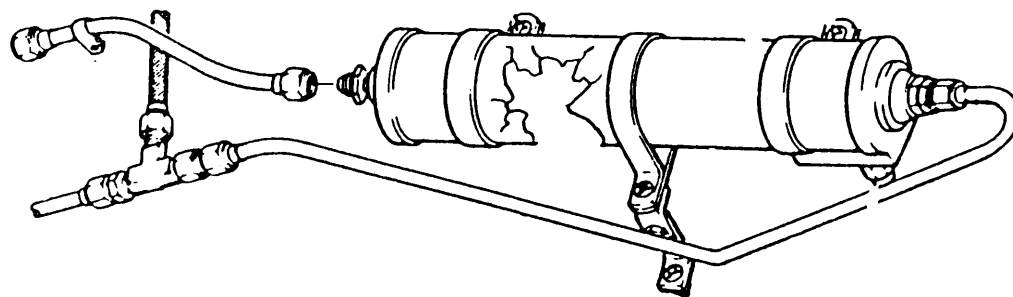

A. DAMAGED PLENUM

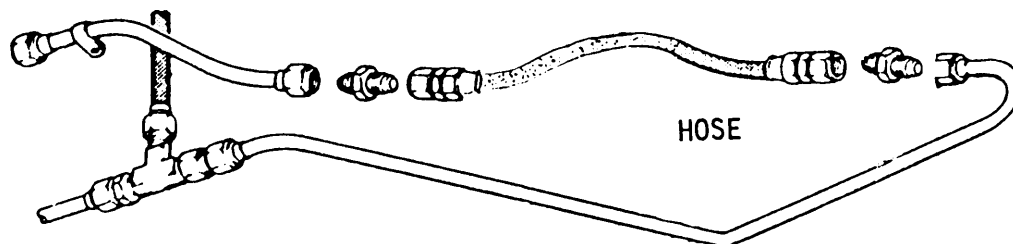

B. INSTALLATION OF BYPASS HOSE

Figure 10-2. Bypassing Damaged Plenum

CHAPTER 11

ELECTRICAL AND AVIONICS SYSTEMS

BDAR FIXES SHALL BE USED ONLY IN COMBAT OR FOR TRAINING AT THE DISCRETION OF THE COMMANDER. (AUTHORIZED TRAINING FIXES ARE LISTED IN APPENDIX E.) IN EITHER CASE, DAMAGES SHALL BE REPAIRED BY STANDARD PROCEDURES AS SOON AS PRACTICABLE.

Section I. INTRODUCTION

11-1. SCOPE.

a. Wire Identification. Added and repaired wiring must be identified to aid in troubleshooting. Tape or sleeving at each end of added wiring of a material suitable for the ambient temperature range may be used. Typical wire and circuit identification schemes are shown in Figure 11-1 and Table 11-1.

b. Circuit Function. The unit number and circuit designation letter identify the type of circuits. The wire number consists of one or more digits. It is used to distinguish between wires in the same circuit. The wire segment letter is used to distinguish between conductor segments (a wire segment between two terminals or connections). The wire size number is used to identify the gage of the wire or cable. The ground, phase, or thermocouple letter(s) are used as suffixes to the wire identification code to further identify certain wires. Ground wires are identified with an N suffix. Phase letters A, B, or C are added to identify the phase of wires that are in the three-phase wiring of alternating current (AC) systems. For thermocouple wire, the following suffixes are added to the identification code: AL (Alumel), CR (Chromel), FE (Iron), CN (Constantan), and CU (Copper).

c. Deferral. Repair of systems and subsystems which have adequate redundancy or are not critical to mission accomplishment may be deferred if safety of flight is not significantly degraded.

The commander may defer combat maintenance and battle damage repair, even if doing so places operational limitation on the aircraft.

11-2. ASSESSMENT PROCEDURES. See Table 11-2 for Electrical and Avionics Systems Assessment.

WARNING

Before assessing and handling systems wiring or components, turn off power to all systems. Damaged equipment can cause severe shock to personnel and additional damage to equipment.

11-3. REPAIR PROCEDURE INDEX.

	<u>PARA.</u>
Splicing Unshielded Wires	11-5
Wire Repair Segments	11-6
Damaged Wire Insulation	11-7
Shielded Cable	11-8
Shielded Cable Segments	11-9
Shield Terminators	11-10
Nickle-Plated Terminators	11-11
Terminal Boards	11-12
Terminal Lucas	11-13
coax cable	11-14
Component Bridging	11-18
Damaged Connector Pins	11-19
Circuit Breaker	11-20
Broken Fuses	11-21"
Power Bus Bar Repair	11-22
Battery Bus Bar Repair	11-23
Power Relay	11-24
Substitute Emergency Antenna	11-26

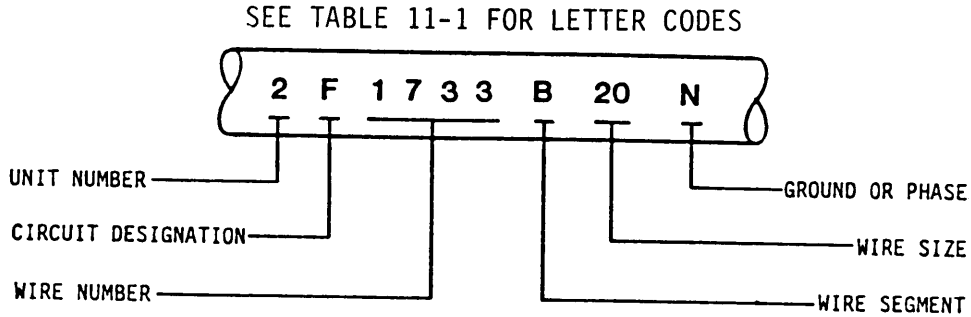

Figure 11-1. Circuit Identification

Table 11-1. Function and Designation Letters

CIRCUIT DESIGNATION LETTER	CIRCUITS	CIRCUIT DESIGNATION LETTER	CIRCUITS
A	<p>ARMAMENT:</p> <ul style="list-style-type: none"> Bomb suspension & release Guns Chemical Rocket Sight Turret Warning External pylons stores Jettison fuel tanks Mine dispenser 	E	<p>ENGINE INSTRUMENT:</p> <ul style="list-style-type: none"> Tail pipe temperature Fuel flow Fuel quantity Fuel capacity Oil temperature Oil pressure Manifold pressure Fuel pressure Engine oil quantity Tachometer Warning
B	<p>PHOTOGRAPHIC:</p> <ul style="list-style-type: none"> Gun camera Mapping camera Reconnaissance camera Camera intervalometer Camera doors Camera heaters Warning 	F	<p>FLIGHT INSTRUMENT:</p> <ul style="list-style-type: none"> Bank and turn Rate of climb Directional gyro Air position Ground position Compass (including flux gate and other stabilized compasses) Gyro horizon Attitude gyro Driftmeter Altimeter Airspeed Accelerometer Pitot-static tube meter Warning
C	<p>CONTROL SURFACE:</p> <ul style="list-style-type: none"> Horizontal stabilizer Warning 		
D	<p>INSTRUMENT (other than flight or engine instruments):</p> <ul style="list-style-type: none"> Ammeter Air pressure Free air temperature Hydraulic pressure Horizontal position stabilizer Voltmeter Clock Warning 		

Table 11-1. Function and Designation Letters (Cont)

CIRCUIT DESIGNATION LETTER	CIRCUITS	CIRCUIT DESIGNATION LETTER	CIRCUITS
H	HEATING, VENTILATING, AND DE-ICING: Anti-icing (general) Battery heater Cabin heater Cigarette lighter De-icing (general) Windshield defroster Windshield defogger Windshield de-icer Heater blanket Oil immersion heater Refrigeration Ventilation Warning		Running, position, navigation Passing Search Taxi Warning
		M	MISCELLANEOUS ELECTRIC: Windshield spray Windshield wiper Hoist Enclosure operation Positioner; seat, pedal Special test equipment
		N	UNASSIGNED
I	In order to avoid confusion with the numeral one, the letter "I" shall not be used for circuit or cable identification.	O	In order to avoid confusion with the numeral zero, the letter "O" shall not be used for circuit or cable identification.
J	IGNITION: Booster Vibrator Distributor Electronic Warning	P	DC POWER
		Q	FUEL AND OIL: Fuel valves Fuel booster-pump motor Moisture control Oil dilution Engine primer Fuel-transfer-pump motor and control Fuel-loading-pump motor Oil transfer-pump motor and control Oil booster pump Oil scavenge pump Throttle control Fuel-pump motor Oil diverter Oil valves Warning
K	ENGINE CONTROL: Blower ratio Starter Warning		
L	LIGHTING: Approach Flasher-coder Cockpit Drift Cabin Formation Cargo Interior Instrument Section (fuselage) Landing Exterior		

Table 11-1. Function and Designation Letters (Cont)

CIRCUIT DESIGNATION LETTER	CIRCUITS	CIRCUIT DESIGNATION LETTER	CIRCUITS
R	RADIO (Navigation and communication): RA-Instrument Landing RC-Command RD-Radio direction finding RF-VHF Liaison RH-Homing RL-Liaison RM-Marker beacon RN-Navigation RP-Special systems RS-SHF command RT-Radio teletype RU-UHF command RV-VHF command RX-Recorder RZ-Interphone, headphone		TR-Receivers TT-Transmitters TU-Reconnaissance TW-Weather devices TZ-Bombing devices
		U	MISCELLANEOUS ELECTRONIC: Electronic wiring for which no "R", "S", or "T", designation has been assigned by the procuring activity shall have the circuit function letter "U" assigned. Examples of wiring for which the circuit function letter, "U" will be assigned are common leads to electronic equipments and systems interconnection wiring such as antenna or power circuits common to more than-one equipment or system.
S	RADAR : SA-Altimeter SF-Intercept SG-Gunlaying SM-Mapping SN-Navigation SQ-Bombing SR-Recorder SS-Search SV-Special systems SW-Warning SX-Recognition (IFF)	V	DC POWER and DC control cables for AC systems.
		W	WARNING AND EMERGENCY Enclosure release and locks Fire extinguishers Flare release Fire detector Intercrew buzzer or light
T	SPECIAL ELECTRONIC: TA-Adapter TB-Radar control TC-Radio control TD-Airborne announcing TE-Electronic countermeasure TF-Repeat back TG-GM homing TH-Infrared TK-Telemetering TL-Attitude indicator TM-Chaff dispenser TN-Navigation TP-Beacon (crash and locator) TQ-Transmitters and receivers	X	AC POWER: Wiring in the AC power system.
		Y	ARMAMENT SPECIAL SYSTEMS: Y*A-Air to air Y*B-Air to surface Y*C-Multimode Y*M-Missile guidance Y*T-Turret * Armament special system number
		Z	UNASSIGNED

Table 11-2. Electrical and Avionics Systems Assessment

<u>ITEM/ACTION</u>	<u>FAULT ISOLATION</u>	<u>BDAR REF.</u>
<u>VISUALLY INSPECT</u>		
a. Inspection Reveals	<p>Damage to</p> <ul style="list-style-type: none"> -unshielded wires Para 11-5 -wire insulation. Para H-7 -shielded cable. Para 11-8 -shield terminators Para 11-10 -nickel-plated shield terminators Para 11-11 -terminal boards. Para 11-12 -terminal lugs Para 11-13 -coax cables Para 11-14 -component. Para 11-18 -connector repair. Para 11-19 <p>Determine if damage</p>	
	<p style="text-align: center;">↓</p> <div style="display: flex; justify-content: space-around;"> <div style="text-align: center;"> <p>can be repaired</p> <p>↓</p> <p>-note repair requirements</p> </div> <div style="text-align: center;"> <p>cannot be repaired</p> <p>↓</p> <p>-note extent of damage</p> </div> </div> <p style="text-align: center;">← continue assessment</p>	
b. Function Test	<p style="text-align: center;">NOTE</p> <ul style="list-style-type: none"> ● Ensure that no power conducting wires will short out to each other or to ground when power is turned on. • Check each system or component individually for test function after BDAR fix is completed. 	
continue next page		

Table 11-2. Electrical and Avionics System Assessment (Cent)

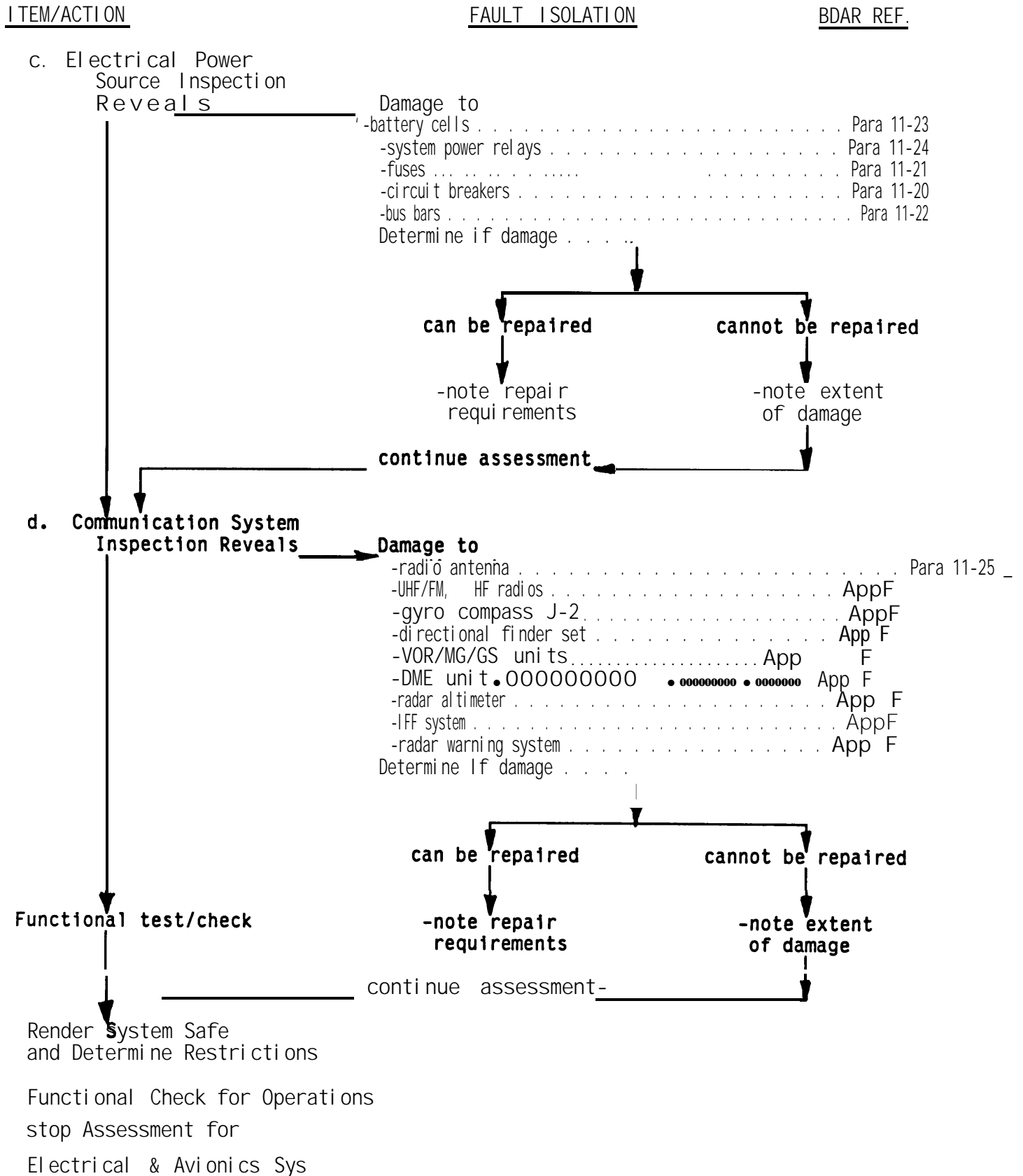

Section 11. WIRE AND CABLE

11-4. GENERAL.

a. BDAR wiring repair provides for two types of aircraft electrical wiring repairs which are classified as "PERMANENT" or "TEMPORARY."

(1) A permanent repair returns the electrical wiring system to full capability, with no degradation of any system operating characteristics. No periodic inspection or replacement is required with a permanent repair.

(2) Temporary repairs must be reinspected at 100 flight hours. At this time, a permanent repair will be performed or an extension of use for the temporary repair will be granted.

(3) Emergency Repair - Good for one-time flight only.

11-5. UNSHIELDED WIRES, DAMAGED.

GENERAL INFORMATION: This procedure provides for repairing damaged unshielded wires.

WARNING

Do not be misled by the term "low voltage." Potentials as low as 50 volts may cause death under adverse conditions.

CAUTION

Ensure aircraft power is OFF.
Disconnect battery before touching any wires.

OPTION 1: Crimp Splice.

LIMITATIONS: Only to be used for wire sizes 12-26. No more than one splice is made per 10 feet of wire. This is a permanent repair.

PERSONNEL/TIME REQUIRED:

- 1 Soldier
- 10 Minutes

MATERIALS/TOOLS REQUIRED:

- Splice (items 145-149, App C)
- Sealing Sleeve (item 66, App C)
- Wire Repair Kit (item 11, Sec I, App B)
 - Crimping Tool
 - Strippers
 - Heat Gun
 - Reflector

PROCEDURAL STEPS:

1. Refer to instructions in wire repair kit.
2. Record BDAR action taken. When mission is complete, as soon as practical, repair the equipment/system using standard maintenance procedures.

OPTION 2: Terminal Lug Splice.

LIMITATIONS: Only to be used on wire size AWG No. 10 and smaller. This is a temporary repair.

PERSONNEL/TIME REQUIRED:

- 1 Soldier
- 15 Minutes Per Splice

MATERIALS/TOOLS REQUIRED:

- Wire Repair Kit (item 11, Sec I, App B)
 - Terminal Lug
 - Insulating Sleeve
 - Crimp Tool

PROCEDURAL STEPS:

- 10 Select a terminal with a barrel large enough to accommodate both wires.
2. Cut off terminal lug tongue.
3. Prepare wire ends.

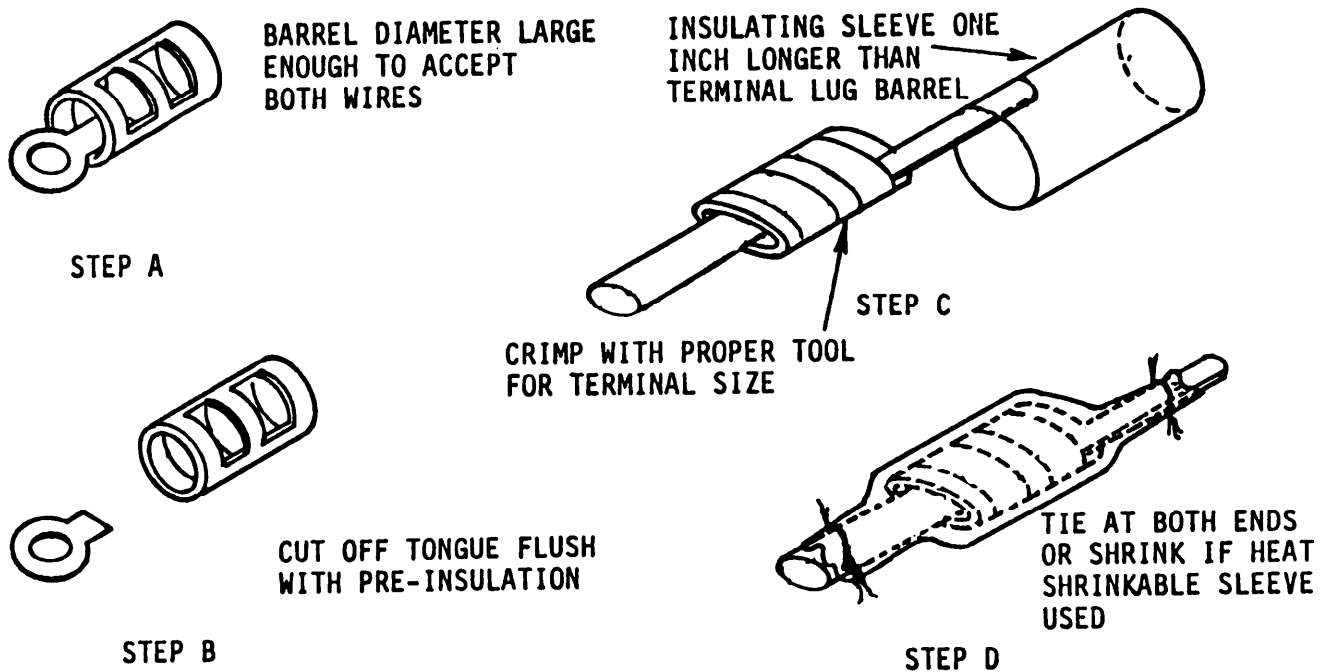

Figure 11-2. Splicing with Terminal Lug Barrel

4. Slip an Insulating sleeve 1 Inch longer than terminal lug barrel over the end of one of the wires, and Insert wire end into the barrel as shown in Figure 11-2.

5. Crimp barrel in center.

6. Slide insulating sleeve over the terminal lug barrel splice, and secure in place by using tie wraps or heating if heat shrink tubing is used.

7. Record BDAR action taken. When mission is complete, as soon as practical, repair the equipment/system using standard maintenance procedures.

OPTION 3: Split Bolt Splice.

LIMITATIONS: Only to be used on wire sizes AWG No. 4 thru No. 10. Temporary repair.

PERSONNEL/TIME REQUIRED:

- 1 Solder
- :10 Minutes

MATERIALS/TOOLS REQUIRED:

- Wire Repair Kit (item 11, Sec I, App B)
- Heat Gun
- Heat Shrinkable Tape
- Heat Shrinkable Tubing
- Reflector
- Split Bolt Splice Connector
- Strippers or Knife

PROCEDURAL STEPS:

10 Refer to instructions in wire repair kit.

2. Record BDAR action taken. When mission is complete, as soon as practical, repair the equipment/system using standard maintenance procedures.

OPTION 4: Twist Wire Splice.

LIMITATIONS: This is an emergency repair.

PERSONNEL/TIME REQUIRED:

- . 1 Soldier
- . 10 Minutes

MATERIALS/TOOLS REQUIRED:

- 1 Wire Repair Kit (item 11, Sec I, App B)
- Tape, Electrical
- Strippers or Knife

PROCEDURAL STEPS:

1. Cut ties and work broken wire to the outside of the bundle.

2. Pull sufficient slack from the wire run toward the break so that there will be no strain on the splice.

30 Wipe wire clean with a clean dry rag.

4. Trim broken ends of the wire.

5* Split all the wire ends.

6. Split the strands of wire apart and twist the matching wires together as shown in Figure 11-3.

7. Cover splice area with electrical tape.

8. If a section of wire needs to be replaced, a double repair can be made, Figure 11-4.

90 Record BDAR action taken. When mission is complete, as soon as practical, repair the equipment/system using standard maintenance procedures.

OPTION 5: Casing Splice Method.

LIMITATIONS: This is an emergency repair for one time flight only.

PERSONNEL/TIME REQUIRED:

- . 1 Soldier
- . 10 Minutes

MATERIALS/TOOLS REQUIRED:

- Cylindrical metal casing such as ball point pen refills, expended cartridges, etc.
- . Wire Repair Kit (item 11, Sec I, App B)
- . Crimp Tool (hammer, pliers, etc)

PROCEDURAL STEPS:

10 Fabricate splices approximately 1 to 2 inches long from small metal casing.

NOTE

Ball point refills or expended cartridge shell casings when cut to length make splices, Figure 11-5.

2. Strip 1/2 to 1 inch insulation from both ends of wire to be spliced.

3. Insert wires into casing splice and crimp tightly with pliers or a hammer and small iron bar.

4. Insulate with tape or use plastic and string, tie in place.

5. Record BDAR action taken. When mission is complete, as soon as practical, repair the equipment/system using standard maintenance procedures.

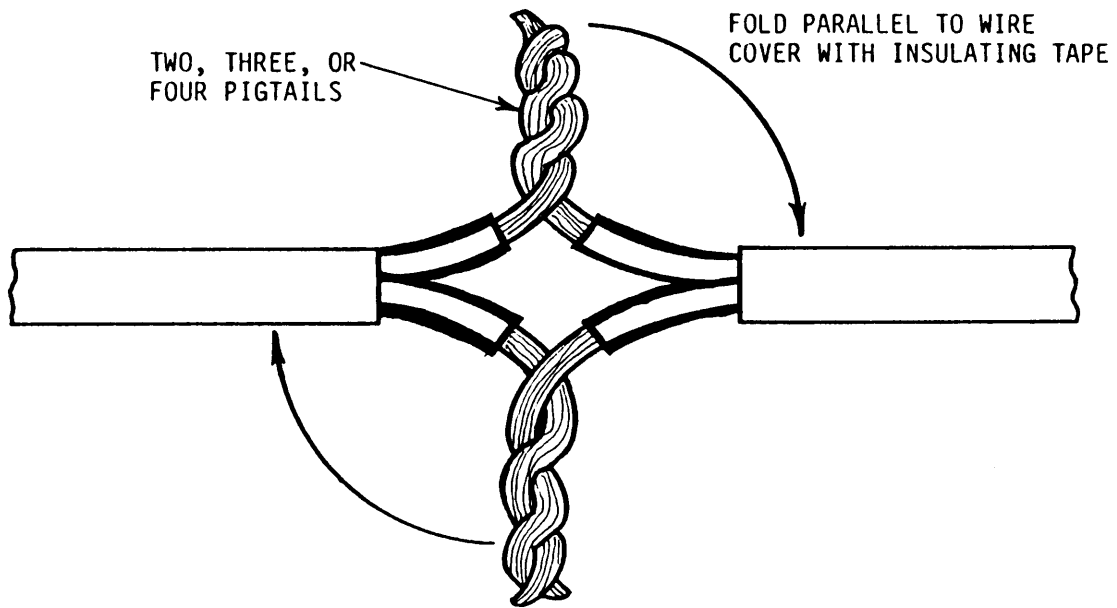

Figure 11-3. Twist Wire Splice

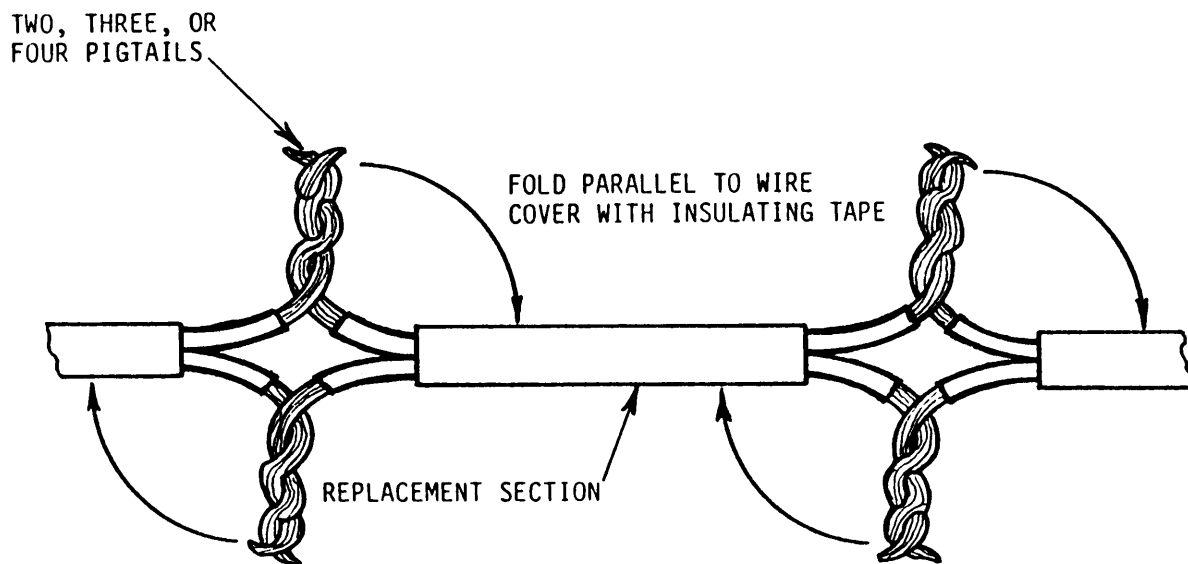
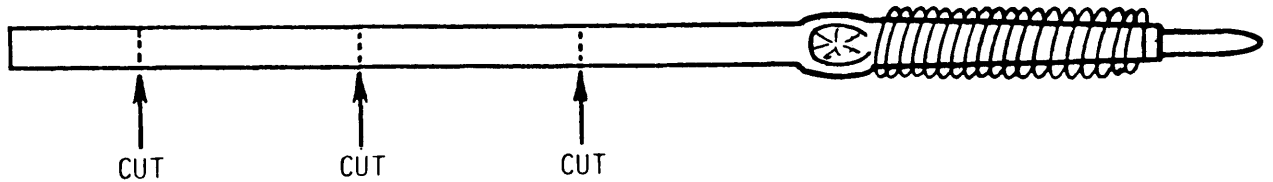
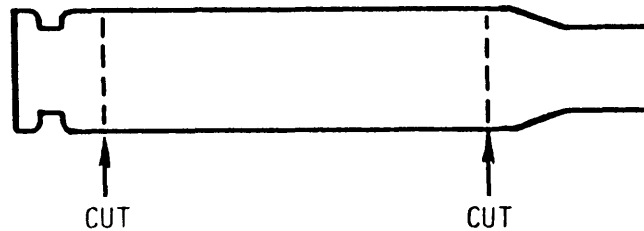

Figure 11-4. Replacement Section; Twist Wire Splice



BALL POINT PEN METAL REFILL (FOR 12 AWG SIZE OR LESS)



EXPENDED CARTRIDGE SHELL CASING

Figure 11-5. Metal Casing Splice Repair

OPTION 6: Bolted Terminal Lug Splice.

LIMITATIONS: This is a temporary repair.

PERSONNEL/TIME REQUIRED:

- 1 Soldier
- 10 Minutes

MATERIALS/TOOLS REQUIRED:

- Wire Repair Kit (item 11, Sec 1, App B)
- Terminal Lugs
- Insulating Sleeve or Tape (App C)
- Screw or Bolt (App C)
- Nut (item 77, App C)
- Washer (item 168, App C)
- Solvent (item 1, App C)

PROCEDURAL STEPS:

1. Cut ties and work broken wire to the outside of the bundle.

2. Pull sufficient slack from the wire run toward the break so that there will be no strain on the splice.

3. Wipe wire clean with a clean, dry rag or a rag dampened with solvent.

4. Trim broken ends of wire and install an insulating sleeve over one end of the wire, and slide back and out of the way for now.

5. Strip both wire ends and crimp an insulated terminal lug of the proper size to each wire end.

6. Bolt terminal lugs together as shown in Figure 11-6.

7. Slide the insulating sleeve over the splice so that the ends of the insulating sleeve extend at least 3/4 of an inch beyond the ends of each terminal lug.

8. Secure both ends of the insulation with tie wraps or string ties as shown in the figure.

9. If a section of wire needs to be replaced, a double repair can be made to bridge the ends of the original wire back together, Figure 11-7

10. Record BDAR action taken. When mission is complete, as soon as practical, repair the equipment/system using standard maintenance procedures.

OPTION 7: Metal Clamp Method.

LIMITATIONS: This is an emergency repair.

PERSONNEL/TIME REQUIRED:

- 1 Soldier
- 10 Minutes

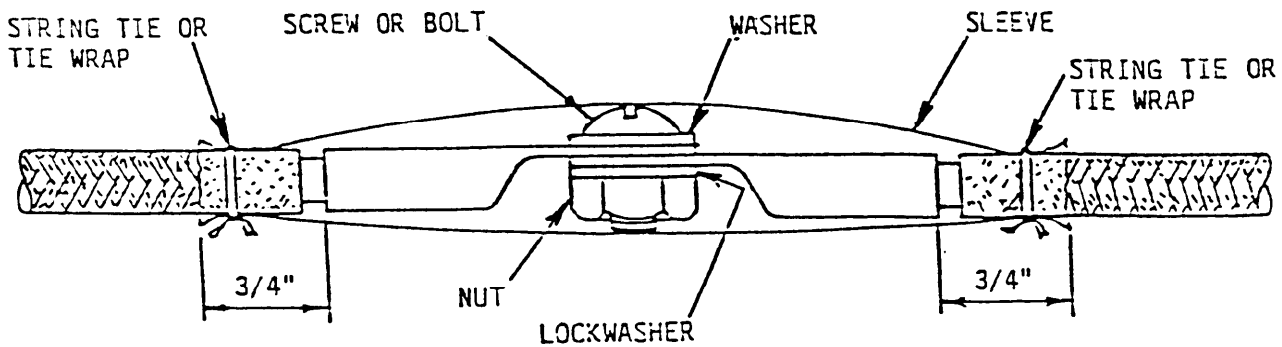

Figure 11-6. Bolted Terminal Lug Repair of Large Wires

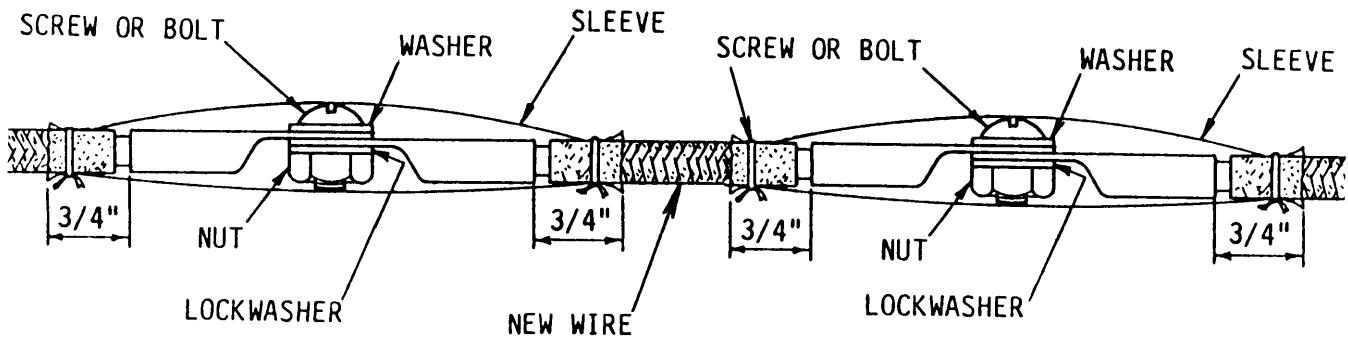

Figure 11-7. Replacement Section; Terminal Lug Repair

MATERIALS/TOOLS REQUIRED:

- Wire Repair Kit (item 11, Sec I, App B)
Screw Clamp, Control Cable Clamp
or Safety Wire
Insulating Sleeve or Electrical Tape
Knife
Solvent Cleaner (item 1, 76, or 167,
App C)

PROCEDURAL STEPS:

1. Cut ties and work broken wire to the outside of the bundle.
2. Pull sufficient slack from the wire run toward the break so that there will be no strain on the splice.
3. Wipe wire clean with a clean dry rag.
4. Trim broken ends of wire.
- 5* Remove 2 inches of wire insulation from each end of the damaged wire.
6. Ram or push the two wire ends together so that the strands interlink.
7. Secure with screw clamp, control cable clamp, safety wire, or other suitable means, Figure 11-8.
8. Insulate with tape or insulation sleeve.
9. Record BDAR action taken. When mission is complete, as soon as practical, repair the equipment/system using standard maintenance procedures.

11-60 WIRE REPAIR SEGMENTS; UNSHIELDED WIRES.

GENERAL INFORMATION: The BDAR electrical wiring kit (item 11, Sec I, App B) has wire replacement segments for replacement sections up to 9 inches in length. The replacement sections are located in compartment B-12, in wire repair kit.

WIRE RAMMED TOGETHER

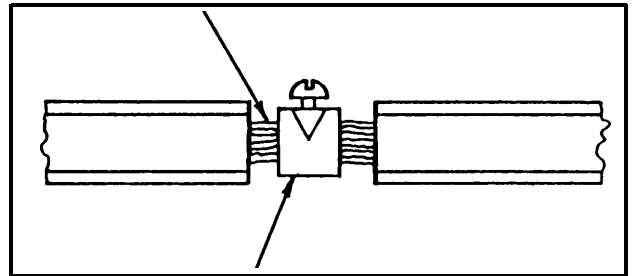

SCREW CLAMP OR EQUIVALENT

Figure 11-8. Ram Wire Repair

CAUTION

Ensure aircraft power is off. Disconnect battery before touching any wires.

LIMITATIONS: This is a permanent repair.

PERSONNEL/TIME REQUIRED:

- 1 Soldier
- 20 Minutes

MATERIALS/TOOLS REQUIRED:

- Wire Repair Kit (item 11, Sec I, App B)
Crimp Tool
Insulation Sleeve or Tape
Replacement Section (Table 11-4)
Splice

PROCEDURAL STEPS:

1. Refer to instructions in wire repair kit.

2. Record BDAR action taken. When mission is complete, as soon as practical, repair the equipment/system using standard maintenance procedures.

11-7. DAMAGED WIRE INSULATION.

GENERAL INFORMATION: If the wire insulation is damaged but the wire itself is not, repair of the insulation may be accomplished by installing heat shrinkable tape, a transparent sleeve of flexible tubing, and securing with nylon braid or some other means.

CAUTION

Ensure aircraft power is off.
Disconnect battery before touching wires.

OPTION 1: Heat Shrinkable Repair Tape.

LIMITATIONS: This is a temporary repair.

PERSONNEL/TIME REQUIRED:

- 1 Soldier
- 10 Minutes

MATERIALS/TOOLS REQUIRED:

- Wire Repair Kit (item 11, Sec I, App B)
Heat Shrinkable Tape
Reflector (2 Types Elec Wiring Kit)
Heat Gun/Heat Source

PROCEDURAL STEPS:

1. Refer to instructions in wire repair kit.

2. Record BDAR action taken. When mission is complete, as soon as practical, repair the equipment/system using standard maintenance procedures.

OPTION 2: Insulation Sleeve.

LIMITATIONS: This is a temporary repair.

PERSONNEL/TIME REQUIRED:

- 1 Soldier
- 10 Minutes

MATERIALS/TOOLS REQUIRED:

- Wire Repair Kit (item 11, Sec I, App B) –
Knife
Insulation Sleeving
String, Nylon Braid, or Tie-Wraps

PROCEDURAL STEPS:

1. Remove damaged insulation and examine to ensure center conductor is not damaged.

2. Prepare a transparent sleeve of flexible tubing 1-1/2 times the outside diameter of the wire and 2 inches longer than the damaged portion of the insulation.

3. Split lengthwise and wrap 1-1/2 times around the wire at the damaged section.

4. Tie with string or other suitable material at each end and at 1 inch intervals over the entire length, Figure 11-9.

5. Record BDAR action taken. When mission is complete, as soon as practical, repair the equipment/system using standard maintenance procedures.

OPTION 3: Tape Insulation.

LIMITATIONS: This is a temporary repair.

PERSONNEL/TIME REQUIRED:

- 1 Soldier
- 5 Minutes Per Wire

MATERIALS/TOOLS REQUIRED:

- Wire Repair Kit (item 11, Sec I, App B)
Knife
Tape, Electrical

PROCEDURAL STEPS:

1. Remove damaged insulation and examine to ensure center conductor is not damaged.

**INSULATING SLEEVING SPLIT LENGTHWISE
AND TIED IN PLACE**

USE TWINE OR ELECTRICAL TIEDOWN
STRAP ITEM 166, APPX. C

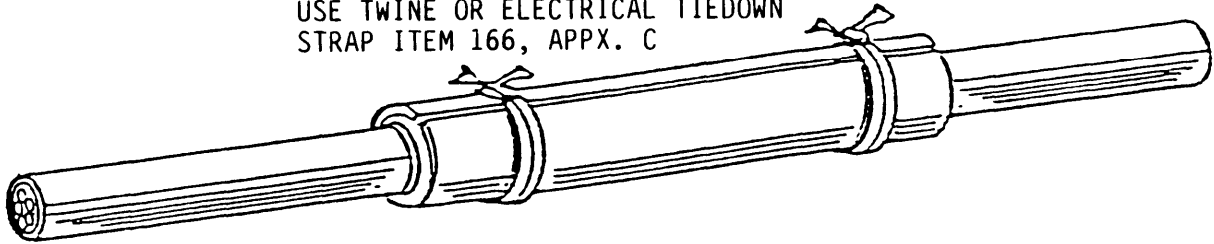

Figure 11-9. Insulation Repair with Sleev ing

2. Wrap tape over exposed center conductor of wire. Tape should extend 2 inches over the wire insulation at each end of the area to be covered.

3. Record BDAR action taken. When mission is complete, as soon as practical, repair the equipment/system using standard maintenance procedures.

11-80 SHIELDED CABLE REPAIR.

GENERAL INFORMATION: The following procedures may be used to repair severed shielded cables.

OPTION 1: Shielded Cable Splice.

LIMITATIONS: This is a permanent repair.

PERSONNEL/TIME REQUIRED:

- 1 Soldier
- 15 Minutes

MATERIALS/TOOLS REQUIRED:

- Wire Repair Kit (item 11, Sec I, App B)
 - Crimping Tool
 - Heat Gun
 - Reflectors
 - Sealing Sleeve (appropriate size)
 - Splice (appropriate size)
 - Strippers

PROCEDURAL STEPS:

1. Refer to instructions in wiring repair kit.

2. Record BDAR action taken. When mission is complete, as soon as practical, repair the equipment/system using standard maintenance procedures.

OPTION 2: Sheath Connector and Grounding Sheath.

LIMITATIONS: This is a temporary repair until heat shrink is installed, then it is a permanent repair.

PERSONNEL/TIME REQUIRED:

- 1 Soldier
- 30 Minutes Per Wire

MATERIALS/TOOLS REQUIRED:

- Wire Repair Kit (item 11, Sec I, App B)
 - Insulating Sleev ing, Heat Shrink or Tape
 - Knife
 - Strung, Nylon Braid, or Tie Wrap (to be used if insulating sleeve is used)
 - 2 Sheath Connectors
 - Grounding Sheath
 - Center Conductor Splice

PROCEDURAL STEPS:

1. Select a grounding sheath.
2. Prepare the severed ends of the cable for application of a grounding sheath as shown in Figure 11-10.

3* Position sheath connector and grounding sheath as shown in Figure 11-10, step B. (NOTE: Crimp sheath connector and grounding sheath only at one side at this time.)

40 Slide insulating sleeve over uncrimped sheath connector as shown Figure 11-10, step B. (NOTE: If insulating sleeve is not available, use shrink or alternate insulating material such as electrical tape.)

5. Splice center conductor using a permanent splice or by using one of the splicing procedures in paragraph 11-6.

6. Push the free end of the grounding wire into the uncrimped grounding sheath connector. Crimp securely, Figure 11-10, step C.

7. If an insulating sleeve is used, slide into place and tie both ends, Figure 11-10, step D. If heat shrink is used, slide into place and shrink into position. If tape is used, use it to cover repair.

8. Record BDAR action taken. When mission is complete, as soon as practical, repair the equipment/system using standard maintenance procedures.

OPTION 3: Pigtailed Sheath Method.

LIMITATIONS: This is a temporary repair.

PERSONNEL/TIME REQUIRED:

- 1 Soldier
- 30 Minutes Per Wire

MATERIALS/TOOLS REQUIRED:

- Wire Repair Kit (item 11, Sec I, App B)
- Knife
- Insulating Sleeving or Tape String, Nylon Braid, or Tie Wrap (to be used if insulating sleeve is used)
- Center Conductor Splice

PROCEDURAL STEPS:

1. Prepare severed ends of cable for pigtail method of shield terminations, Figure 11-11, step A.

2. Splice center conductor, Figure 11-11, step B, using a permanent splice or by using one of the splicing procedures in paragraph 11-6.

3. Use two splice connectors to add short length of insulated wire as extension to complete shield connection, Figure 11-11, step B.

4. Insulate repair, Figure 11-11, step C.

5. Record BDAR action taken. When mission is complete, as soon as practical, repair the equipment/system using standard maintenance procedures.

OPTION 4: Substitute Shielded Braid.

LIMITATIONS: This is a temporary repair.

PERSONNEL/TIME REQUIRED:

- 1 Soldier
- 30 Minutes Per Wire

MATERIALS/TOOLS REQUIRED:

- Wire Repair Kit (item 11, Sec I, App B)
- Substitute Shielded Braid
- Knife
- Center Conductor Splice
- Metal Screw Clamp, Sheath Connector, or Equivalent
- Shield Terminator

PROCEDURAL STEPS:

1. Prepare severed ends of cable for application of repair splice and shielding, Figure 11-12, step A.

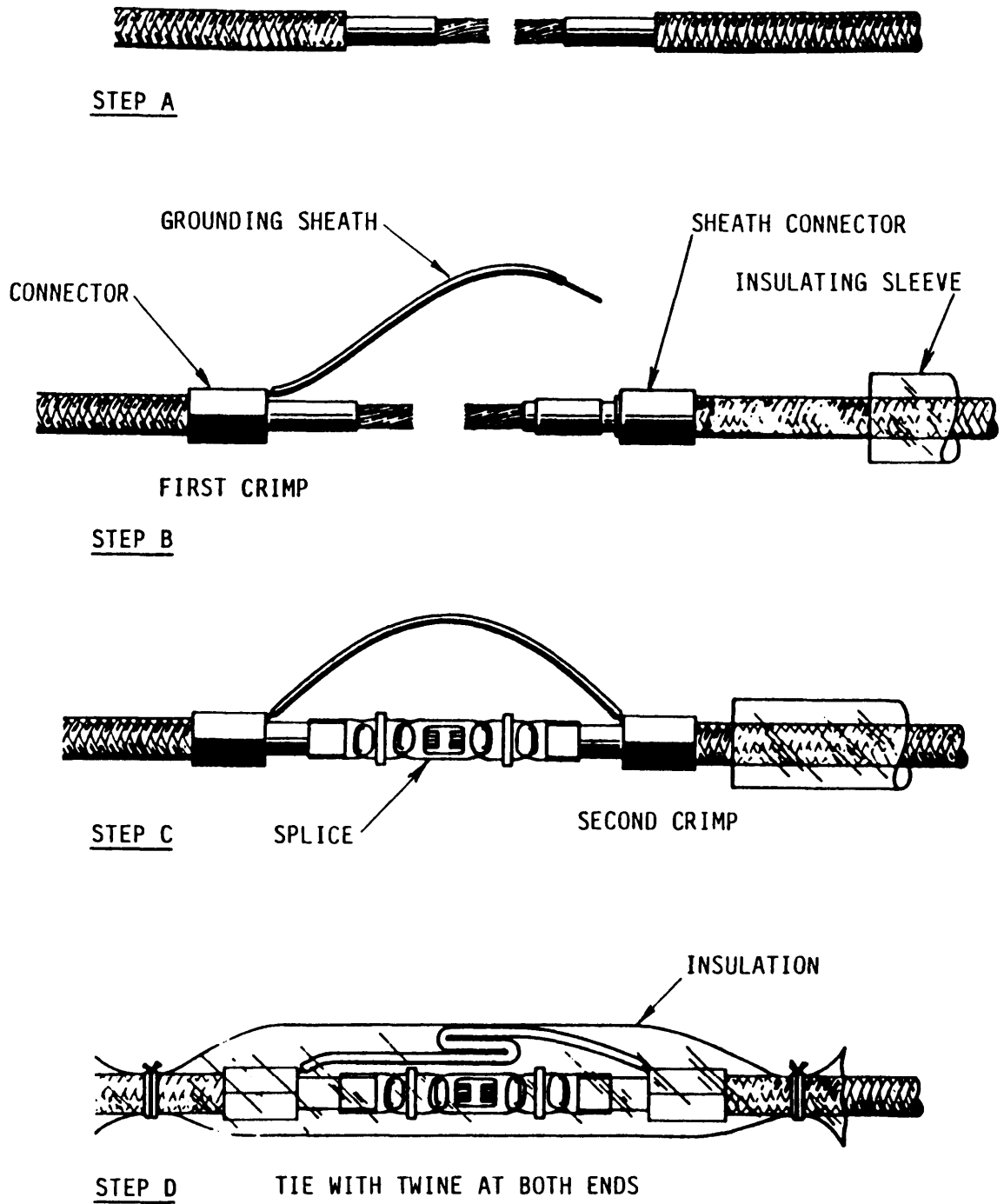

Figure 11-10. Shielded Cable Repair

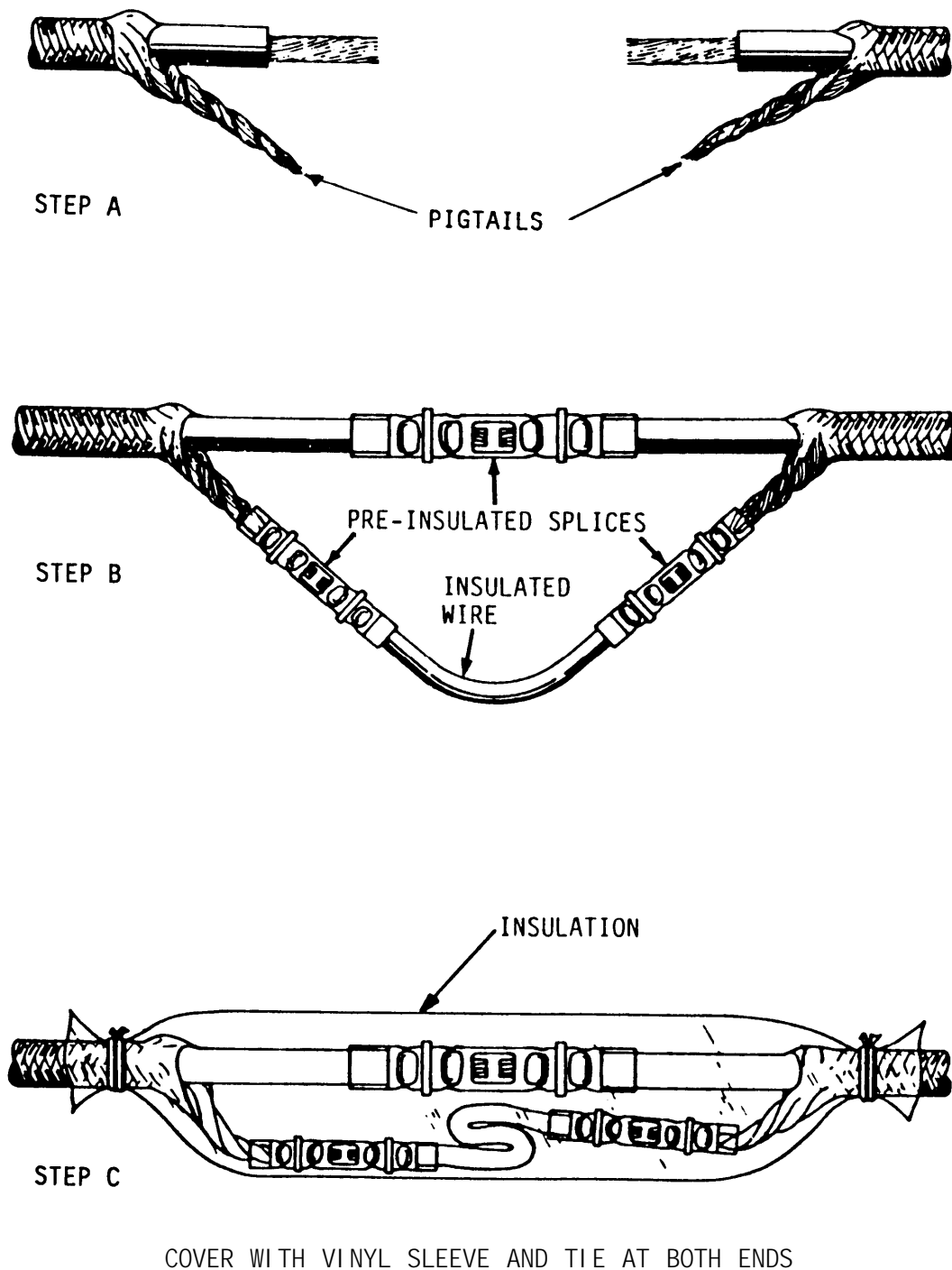
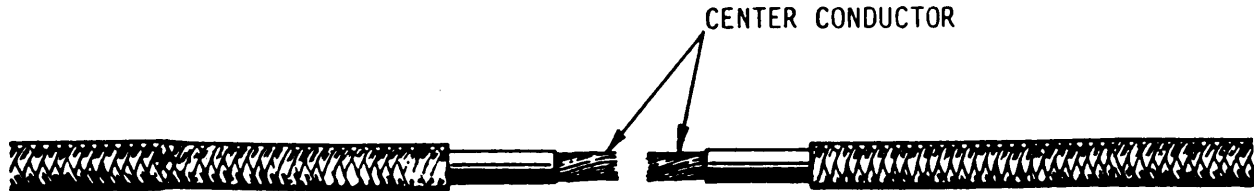
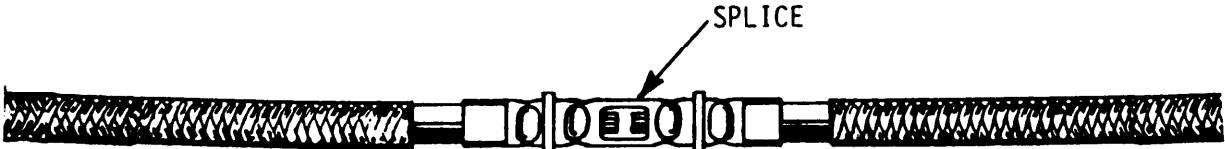

Figure 11-11. Pigtail Method Repair



STEP A



STEP B

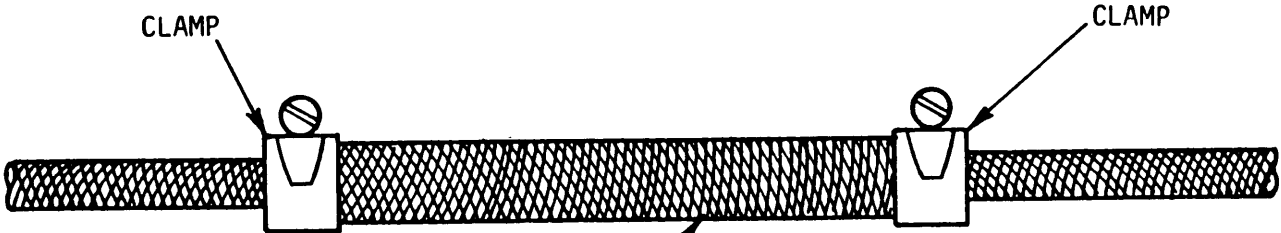

STEP C

SUBSTITUTE SHIELD

Figure 11-12. Substitute Shielded Braid Repair

2. Select suitable shielding material and slide over one end of severed cable. Shielding must be long enough to overlap the shielding on both sides of the cable **being** repaired after the center conductor is repaired. Shielding material can be obtained from another shield cable or ground cable material.

NOTE

It is essential that the shielding, as well as the inner conductor, be repaired properly to prevent electromagnetic interference (EMI) problems.

3. Splice center conductor using a permanent splice or by using one of the splicing procedures in paragraph 11-5 and Figure 11-12, step B.

4. Slide shielding material over repaired inner conductor and clamp at shielding overlap areas, Figure 11-12, step C.

5. Record BDAR action taken. When mission is complete, as soon as practical, repair the equipment/system using standard maintenance procedures.

11-9. SHIELDED CABLE REPAIR SEGMENTS.

GENERAL INFORMATION: The electrical wiring kit has wire replacement segments for replacement sections up to 9 inches in length. The replacement sections are located in compartments of wire repair Kit.

CAUTION

Ensure aircraft power is off.
Disconnect battery before touching any wires.

LIMITATIONS: This is a permanent repair.

PERSONNEL/TIME REQUIRED:

- 1 Soldier
- 1 Hour

MATERIALS/TOOLS REQUIRED:

- Wire Repair Kit (item 11, Sec I, App B) –
Replacement Section
Stripper or Knife
Splice
Insulation Sleeve
Crimp Tool

PROCEDURAL STEPS:

1. Refer to wire repair kit.
2. Record BDAR action taken. When mission is complete, as soon as practical, repair the equipment/system using standard maintenance procedures.

11-10. SHIELD TERMINATORS.

GENERAL INFORMATION: The kit (item 11, Sec I, App B) contains various types of shield terminators for shielded cable.

LIMITATIONS: This is a temporary repair.

PERSONNEL/TIME REQUIRED:

- 1 Soldier
- 15 Minutes

MATERIALS/TOOLS REQUIRED:

- Wire Repair Kit (item 11, Sec I, App B)
Shield Terminator
Reflector
Heat Gun/Heat Source
Stripper or Knife
Insulating Sleeve

PROCEDURAL STEPS:

1. Refer to wire repair kit.
2. Record BDAR action taken. When mission is complete, as soon as practical, repair the equipment/system using standard maintenance procedures.

11-11. TERMINATORS FOR NICKEL-PLATED SHIELDS (INCLUDING VERMILION).

GENERAL INFORMATION: The kit contains shield terminators for nickel-plated shields, including vermilion.

LIMITATIONS: This is a permanent repair.

PERSONNEL/TIME REQUIRED:

- 1 Soldier
- 15 Minutes

MATERIALS/TOOLS REQUIRED:

- Wire Repair Kit (item 11, Sec I, App B)

PROCEDURAL STEPS:

1. Refer to wire repair kit.
2. Record BDAR action taken. When mission is complete, as soon as practical, repair the equipment/system using standard maintenance procedures.

11-12. TERMINAL BOARDS.

GENERAL INFORMATION: The terminal boards provided are all five inches in length. They are located in wiring repair kit. They can be cut to shorter lengths using a hacksaw.

LIMITATIONS: Permanent repair.

PERSONNEL/TIME REQUIRED:

- 1 Soldier
- Time will depend on the number of wires on the terminal board in question.

MATERIALS/TOOLS REQUIRED:

- Wire Repair Kit (item 11, Sec I, App B)
- Replacement Terminal Board

PROCEDURAL STEPS:

1. Refer to wire repair kit.
2. Record BDAR action taken. When mission is complete, as soon as practical, repair the equipment/system using standard maintenance procedures.

11-13. TERMINAL LUGS.

GENERAL INFORMATION: Terminal lugs are provided in the wiring repair kit (item 11, Sec I, App B). They are located in compartments of wire repair kit. The general procedure for installing terminal lugs is as follows:

LIMITATIONS: Permanent repair.

PERSONNEL/TIME REQUIRED:

- 1 Soldier
- 10 Minutes Per Wire

MATERIALS/TOOLS REQUIRED:

- Wire Repair Kit (item 11, Sec I, App B)
- Strippers or Knife
- Replacement Terminal Lug
- Crimp Tool

PROCEDURAL STEPS:

1. Refer to wire repair kit.
2. Record BDAR action taken. When mission is complete, as soon as practical, repair the equipment/system using standard maintenance procedures.

11-14. COAX SPLICE FOR RG-136/U AND RG-179B/U.

GENERAL INFORMATION: There are various coax splices in the wiring repair kit that may be used for the different types and sizes of coax cable.

LIMITATIONS: This is a temporary repair.

PERSONNEL/TIME REQUIRED:

- 1 Soldier
- 15 Minutes

MATERIALS/TOOLS REQUIRED:

- Wire Repair Kit (item 11, Sec I, App B)
 - Coax Splice
 - Stripper or Knife
 - Crimp Tool, AD-1377
 - Reflector
 - Heat Gun/Heat Source

PROCEDURAL STEPS:

1. Refer to wire repair kit.
2. Record BDAR action taken. When mission is complete, as soon as practical, repair the equipment/system using standard maintenance procedures.

11-15. COAX SPLICE FOR RG-180B/U, RG-124/U, RG-142B/U, RG-302/U, RG-303/U.

GENERAL INFORMATION: There are various coax splices in the wiring repair kit that may be used for the different types and sizes of coaxial cable.

LIMITATIONS: This is a temporary repair.

PERSONNEL/TIME REQUIRED:

- 1 Soldier
- 15 Minutes

MATERIALS/TOOLS REQUIRED:

- Wire Repair Kit (item 11, Sec I, App B)
 - Crimp Tool, AD-1377
 - Coax Splice
 - Stripper or Knife
 - Reflector
 - Heat Gun/Heat Source

PROCEDURAL STEPS:

1. Refer to wire repair kit.
2. Record BDAR action taken. When mission is complete, as soon as practical, repair the equipment/system using standard maintenance procedures.

11-16. COAX SPLICE FOR RG-9B/U, RG-214/U, RG-225/U, RG-393/U.

GENERAL INFORMATION: There are various coax splices in the wiring repair kit that may be used for the different types and sizes of coax cable.

LIMITATIONS: This is a temporary repair.

PERSONNEL/TIME REQUIRED:

- 1 Soldier
- 15 Minutes

MATERIALS/TOOLS REQUIRED:

- Wire Repair Kit (item 11, Sec I, App B)
 - Crimp Tool, AD-1377
 - Coax Splice
 - Stripper or Knife
 - Reflector
 - Heat Gun/Heat Source

PROCEDURAL STEPS:

1. Refer to wire kit.
2. Record BDAR action taken. When mission is complete, as soon as practical, repair the equipment/system using standard maintenance procedures.

11-17. COAX SPLICE FOR RG-58C/U, RG-233/U, RG-59B/U, AND RG-71B/U.

GENERAL INFORMATION: There are various coax splices in the wiring repair kit that may be used for the different types and sizes of coax cable.

LIMITATIONS: This is a temporary repair.

PERSONNEL/TIME REQUIRED:

- 1 Soldier
- 15 Minutes

MATERIALS/TOOLS REQUIRED:

- Wire Repair Kit (item 11, Sec I, App B)
 - Coax Splice
 - Stripper or Knife
 - Reflector
 - Heat Gun

PROCEDURAL STEPS:

- 10 Refer to wire repair kit.
2. Record BDAR action taken. When mission is complete, as soon as practical, repair the equipment/system using standard maintenance procedures.

11-18. COMPONENT BRIDGING.

GENERAL INFORMATION. In most cases it will be quicker not to replace bulkhead connectors, junction boxes, or terminal strips. These circuits can be repaired by "bridging" the damaged area with jumper wires spliced in to eliminate the damaged area or component, Figure 11-13.

LIMITATIONS. Temporary repair.

PERSONNEL/TIME REQUIRED:

- . Will be dependent on the type of splice used.

MATERIALS/TOOLS REQUIRED:

- . Wire Repair Kit (item 11, Sec I, App B)

PROCEDURAL STEPS:

1. Identify wires to be bridged together.
2. Splice wires and jumper wires together using one of the splicing techniques of this chapter.
3. Secure jumper wires after repair is made.
4. Record BDAR action taken. When mission is complete, as soon as practical, repair the equipment/system using standard maintenance procedures.

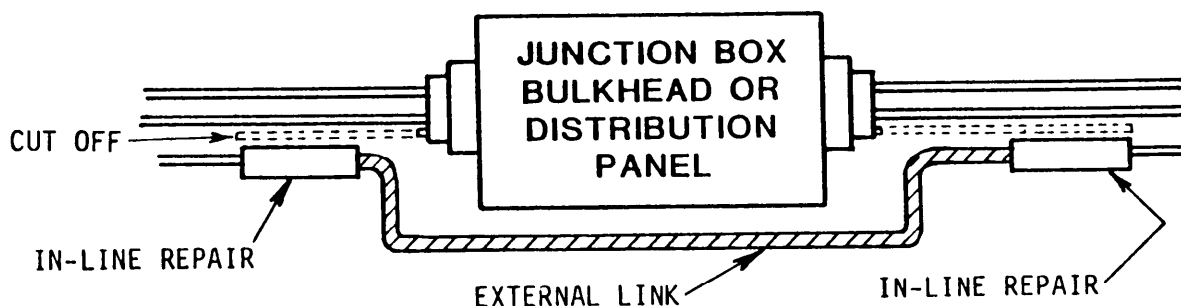

Figure 11-13. Component Bypass

Section III. CONNECTOR REPAIR

11-19* DAMAGED CONNECTOR PINS.

GENERAL INFORMATION: Deformed, crushed, missing, or otherwise damaged connectors can be replaced or repaired. If a replacement connector is not available to replace a crushed connector, clean up fragments of the connector and use

jumper wires to bridge wire ends together. If only part of the connector has been damaged and there are unused pins/sockets on the connector which are undamaged, wires on both sides of the connectors can be moved to the unused good pins/sockets. Also, any available undamaged pigtails on the connector may be used.

OPTION 1: Replace Damaged Pins or Sockets; No Damage to Connector.

LIMITATIONS: Permanent Repair.

PERSONNEL/TIME REQUIRED:

- 1 Soldier
- 10 Minutes Per Wire

MATERIALS/TOOLS REQUIRED:

- Connector Repair Kit (item 2, Sec I, App B)
- Wire Repair Kit (item 11, Sec I, App B)
- Replacement Pins/Sockets
- Insertion/Extraction Tool
- Knife

PROCEDURAL STEPS:

1. Remove damaged pins or sockets from connector.
2. Cut damaged pins or sockets off wire.
3. Strip wire ends.
4. Crimp wires to pin/sockets, Figure 11-14.
5. Insert the pins/sockets into the connector.
6. Record BDAR action taken. When mission is complete, as soon as practical, repair the equipment/system using standard maintenance procedures.

OPTION 2: Bridge Across Damaged Connector. Refer to paragraph 11-18, component bridging and splicing.

LIMITATIONS: Temporary repair.

MATERIALS/TOOLS REQUIRED:

- Wire Repair Kit (item 11, Sec I, App B)
- Wire splice
- Wire

PROCEDURAL STEPS:

1. Locate the damaged wire ends that go into connector.

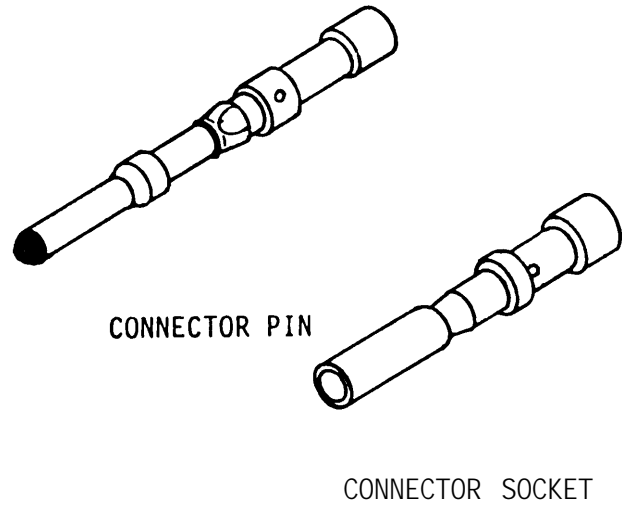

Figure 11-14. **Connector Pin and Socket**

2. Splice the appropriate wires together. The splice will bypass the connector.
3. Record BDAR action taken. When mission is complete, as soon as practical, repair the equipment/system using standard maintenance procedures.

OPTION 3: Cannibalize Connector from Other Aircraft.

LIMITATIONS: None.

MATERIALS/TOOLS REQUIRED:

- Wire Repair Kit (item 11, Sec I, App B)
- Replacement Connector with Pigtail
- Splices or Tape
- Knife

PROCEDURAL STEPS:

1. Obtain a replacement connector with a pigtail. (Replacement may be obtained from a crash damaged aircraft.) Cut pigtail so that splices can be staggered, Figure 11-15.

2. Remove damaged connector; stagger the wires being cut to remove the damaged connector. The staggered wires should match the staggered pigtail of the replacement connector of step 1, Figure 11-15.

3. Splice the appropriate wires together.

4. Record BDAR action taken. When mission is complete, as soon as practical, repair the equipment/system using standard maintenance procedures.

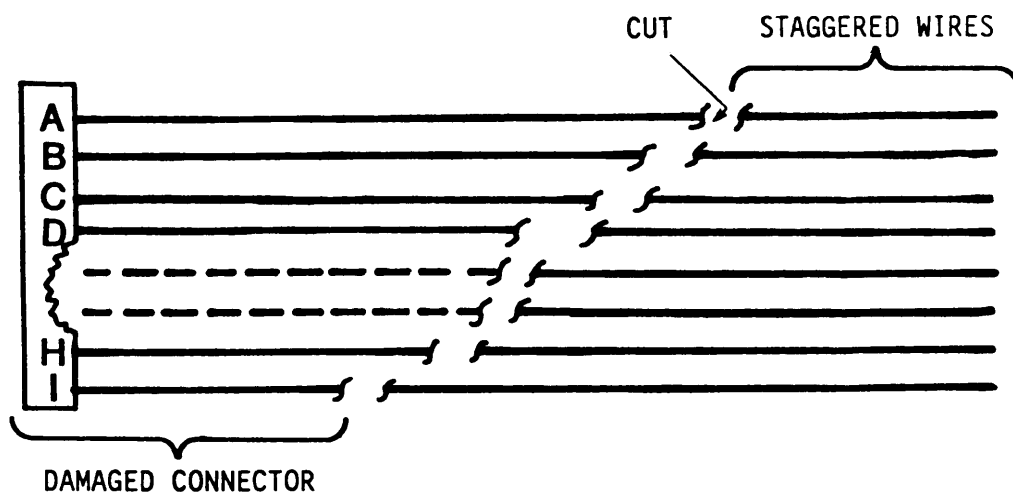

Figure 11-15. Damaged Connector and Pigtail

Section IV. CIRCUIT OVERCURRENT PROTECTION DEVICES

11-20. CIRCUIT PROTECTION DEVICE REPAIR. LIMITATIONS: None.

GENERAL INFORMATION: Attempt to maintain a fused system at all times. Circuits with damage circuit breakers can be repaired by:

a. Circuit breakers of the same rating salvaged from other non-flyable aircraft or removed from other non-essential circuits in the aircraft.

b. Replacing circuit breakers with a specified number of solid wire strands (0.0039 inch diameter/No. 38 AWG). Solid wire strand can be made from a No. 26 AWG stranded wire.

OPTION 1: Salvaged Circuit Breaker Replacement.

PERSONNEL/TIME REQUIRED:

- 1 Soldier
- 20 Minutes

MATERIALS/TOOLS REQUIRED:

- Salvaged Circuit Breaker
- Electrical Tape

PROCEDURAL STEPS:

1. Gain access to area behind circuit breaker panel by turning dzus fasteners counter clockwise.
2. Remove screws holding plastic face plate on circuit breaker panel.

3. Use pliers to remove nut and inside star lockwasher from damaged circuit breaker.
4. Use phillips screw driver to remove the two screws from the back of the circuit breaker.
5. Replace bad circuit breaker with the salvaged circuit breaker.
6. Connect back of circuit breaker to line and bus bar by reinstalling the two phillips screws.
7. Place inside star washer and nut on front of circuit breaker and tighten with pliers.
8. Replace plastic face plate on front of circuit breaker panel with screws previously removed.
9. Clean and remove any debris from inside circuit breaker panel and close panel. Secure by turning dzus fasteners clockwise.

OPTION 2: Solid Wire Strands of No. 38 AWG as Circuit Breaker BDAR Repair.

LIMITATIONS: Emergency.

PERSONNEL/TIME REQUIRED:

- 1 Soldier
- 20 Minutes

MATERIALS/TOOLS REQUIRED:

- Wire Repair Kit (item 11, Sec I, App B)
- No. 8 Terminal Lugs
- 1 Ft. of No. 26 AWG Wire (item 183, App C)

PROCEDURAL STEPS:

1. Perform steps 1 thru 4 of option 1, and remove circuit breaker.
2. Identify the wires hooked to each circuit breaker.

3. Determine amperage of damaged circuit breaker(s) to be replaced. (Amperage is printed on the end of reset button.)
4. Use Table 11-3 to determine number of strands of No. 38 AWG wire needed to replace damaged circuit breaker.
5. Strip No. 26 AWG wire, select number of No. 38 AWG wire strands (6 to 8 inches long) as per Table 11-3. Save insulation and cut into 1 inch lengths (one length for each fuse link required).

Table 11-3 Fuse Link

CIRCUIT BREAKER AMPERAGE	AWG SIZE WIRE	NO. OF STRANDS
112A	NO. 38	1
1A	NO. 38	1
2A	NO. 38	1
3A	NO. 38	1
4A	NO. 38	2
5A	NO. 38	2
10A*	NO. 38	5*
15A*	NO. 38	7*
20A*	NO. 38	10*

* Signifies Extrapolated Values

6. Cut line side wire 1 inch from terminal lug; strip both ends and crimp an 8-32 terminal lug where wire was cut and stripped.

NOTE

Try to use inner strands of wire that are not cut or nicked by knife used to remove insulation.

7. Twist the No. 38 AWG strands of wire, from step 5, together **and insert** the end of line side of terminal lug, wrap and twist as shown in Figure 11-16. Slip 1 Inch piece of Insulation over No. 38 AWG strands of wire. Insert the other end of No. 38 AWG strands of wire into the other terminal lug (supply side), pull tight against the piece of insulation and twist tight, Insulate bare end of terminal lugs on both sides of 1 Inch piece of insulation with **tape**. Use 8-32 screw to connect other terminal lug to bus side of bus bar.

8. Use this procedure to replace **damaged** circuit breaker.

9. Secure fuse link to other wiring with tape to avoid pinching wire when circuit breaker panel is closed.

10. Clean up damaged area behind circuit breaker panel to remove debris, and use tape to insulate any damaged parts that might cause electrical shorts.

11. Carefully close circuit breaker panel and secure by turning dzus fasteners clockwise.

12. Record BDAR action taken. When mission is complete, as soon as practical, repair the equipment/system using standard maintenance procedures.

11-210 BROKEN FUSES.

GENERAL INFORMATION: If a fuse is broken, It may be replaced by another fuse or a piece of solder or wire. A replacement fuse must be of the same physical size. It should be of the same current rating and type, fast blow, or slow blow. Where the same current rating fuse is not available, one as close to proper as possible should be used. A slow blow fuse could be replaced by a fast blow fuse of higher current rating while a fast blow fuse could be replaced by a slow blow fuse of lower current rating. The solder or wire should be used only when no fuse is available.

CAUTION

If the fuse is blown, the same procedure can be used but the cause of the fuse blowing must be fixed. Substituting for the fuse without fixing the cause of blowing can cause more damage to the fused equipment.

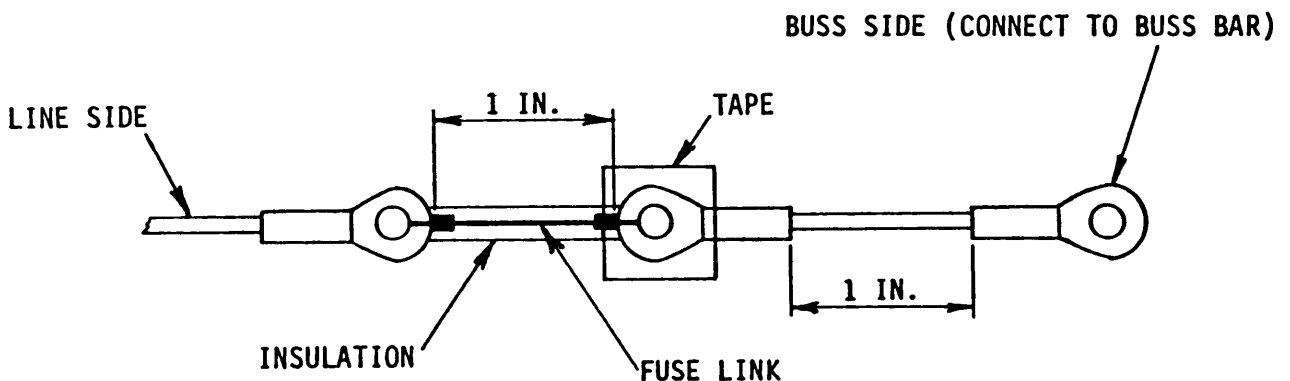

Figure 11-16. Construction of Fuse Link

LIMITATIONS: If too low a current rating fuse is used, it will blow from the turn on surge current. If too high a current rating fuse or if the solder or wire is used, the equipment will not be properly protected in case of a short circuit and could be destroyed. The decision to use a high current rating fuse, solder, or wire should be made by the commander.

OPTION 1: Salvaged Fuse Replacement.

PERSONNEL/TIME REQUIRED:

- 1 Soldier
- 30 Minutes

MATERIALS/TOOLS REQUIRED:

- Spare Fuse

PROCEDURAL STEPS: Replace fuse with the following steps in order.

- a. An identical spare fuse from other equipment.
- b. An identical fuse from the other equipment of lower priority.
- c. A similar fuse.

OPTION 2: No. 38 AWG Strands (0.0039 in. diameter as Fuse BDAR Repair.

LIMITATIONS: Emergency.

PERSONNEL/TIME REQUIRED:

- 1 Soldier
- 1 Hour

MATERIALS/TOOLS REQUIRED:

- Wire Strand NO. 38 AWG Wire (item 183, App C)
- Small Dowel, Stick, or Piece of Pencil
- Electrical Tape (item 154, App C)

PROCEDURAL STEPS:

- 10 Remove damaged fuse.
2. If type A fuse, break off glass of ceramic part and salvage end caps. If type B fuse, break off clear top portion.

3. For type A fuse, cut wire, and dowel, stick or pencil piece to proper length. Refer to Table 11-3 to determine the number of No. 38 AWG wire to use for the different site, amperage, and fuses. See Figure 11-17 for fuse assembly and assemble as follows:

- a. Lay wire piece between caps.
- b. Trim dowel, stick or pencil piece as necessary to fit into end caps, and hold wire in place. This stiffens the substitute fuse.
- c. Wrap dowel, stick or pencil piece and wire with electrical tape, but do not cover end caps.

4. For type B fuse, connect substitute No. 38 AWG wire from point A to point B, Figure 11-18. Use Table 11-3 to determine the number of No. 38 AWG strand to use between points A and B for different size, amperage, and fuses.

5. Install fuse into equipment.

6. Record BDAR action taken. When mission is complete, as soon as practical, repair the equipment/system using standard maintenance procedures.

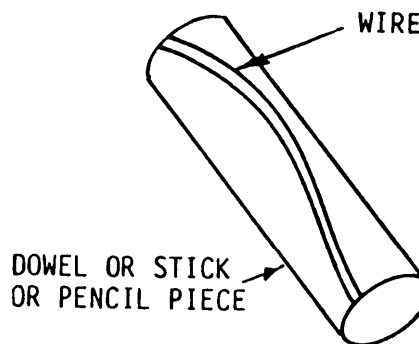

Figure 11-17. Fabricated Fuse, Type A

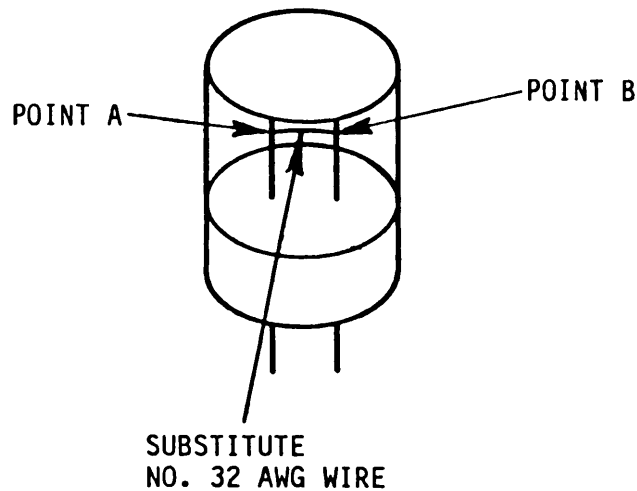

Figure 11-18. Fabricated Fuse, Type B

Section V. BUS BARS

11-22. POWER BUS BAR REPAIR.

GENERAL INFORMATION: Rigid bus bars are used in the power distribution circuits of the aircraft. Replace damaged bus bars with aluminum or brass strips of the same or higher cross-sectional area.

OPTION: Fabricate Bus Bar.

LIMITATIONS: Repaired bus bars will have a somewhat higher resistance than the original circuit and a higher than normal voltage drop may occur. This is a temporary repair.

PERSONNEL/TIME REQUIRED:

- 2 Soldiers
- 2 Hours

MATERIALS/TOOLS REQUIRED:

- Drill & Bit Set (item 67, Sec II, App B)
- Nuts, Bolts, Flat Washers, Lock Washers (App C)
- Tape (item 154, App C)
- Files (items 80-88, Sec II, App B)
- Hacksaw (item 94, Sec II, App B)

PROCEDURAL STEPS:

1. Cut a section of another bus bar or piece of aluminum scrap to use for splice.
2. Drill matching holes in bus bar sections and splice, Figure 11-19.
3. Remove insulation from bus bar only where needed. Ensure contact surfaces of cracked bus bar and splice are smooth, and clean to reduce resistance. If necessary, use file and wire brush to dress and prepare contact surfaces.
4. Install bolts and washers and tighten. Ensure no contact of bolts with aircraft structure.
5. Insulate repair with tape or slit a piece of insulating tubing. Wrap it around the repair and tie it with string.
6. Same repair procedure can be used to lengthen bus bars, Figure 11-20.

7. Record BDAR action taken. When mission is complete, as soon as practical, repair the equipment/system using standard maintenance procedures.

11-23. BATTERY BUS BAR REPAIR.

GENERAL INFORMATION: Nickel-Cadmium (Ni-Cad) consists of a number of cells connected in series. Damage to a cell which does not result in destruction of the battery may be repairable. This procedure gives instructions for locating and removing bad Ni-Cad battery cells and creating a bus bar jumper around the bad cell.

WARNING

Ni-Cad batteries use potassium hydroxide, a strong caustic alkali, as the electrolyte. Do not get this electrolyte on your skin or in your eyes. Use rubber gloves, rubber apron, and protective goggles when handling the electrolyte. If accidental contact with the electrolyte is made, use ONLY clean water and immediately (seconds count) flush contaminated areas. Continue flushing with large quantities of clean water and get medical attention as soon as possible.

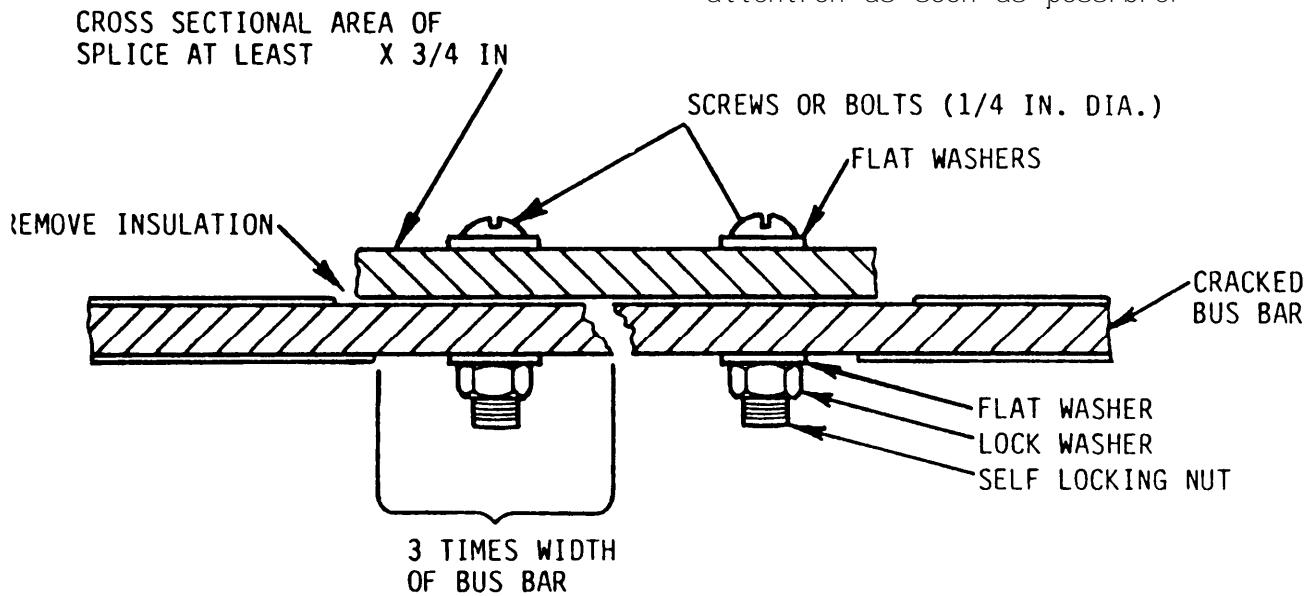

Figure 11-19. Splicing Bus Bars

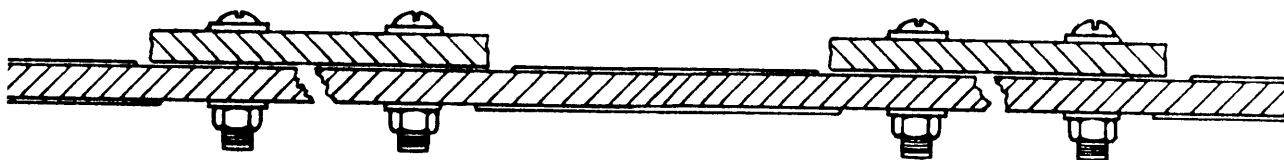

Figure 11-20. Lengthening Bus Bars

WARNING

Cell temperature should never exceed 120°F - 130°F. If steam or spewing electrolyte is observed or the battery is hot to the touch, DO NOT attempt to remove from the aircraft.

CAUTION

Penetration of battery case by small arms fire or shrapnel may cause thermal runaway. The battery cells will overheat and rupture, melt, or explode. Exercise extreme caution when repairing damaged battery.

OPTION: Jumper Cells.

LIMITATIONS: Some loss of battery voltage (1.25 to 1.50 V dc per cell removed) and amperage.

PERSONNEL/TIME REQUIRED:

- 1 Soldier
- 30 Minutes

MATERIALS/TOOLS REQUIRED:

- Multimeter with Leads (item 10, Sec I, App B)
- Rubber Gloves
- Protective Goggles
- Rubber Apron
- Torque Wrench (items 270-272, Sec II, App B)
- Gauge Wire and Terminal Lugs

PROCEDURAL STEPS:

1. Disconnect battery and remove from aircraft if necessary.
2. Release snap fasteners and remove cover.
3. Use a multimeter to measure voltage across each cell. Normal readings should be 1.25 to 1.5 V dc per cell.

Remove cells that are dead. For engine cranking loads, cell voltages as low as 0.6 V dc are acceptable. Also, remove any damaged, cracked, or extremely hot cells leaking or spewing electrolyte.

WARNING

Be extremely careful when removing or installing battery cells. Bodily injury and equipment damage may result if any metal tools or parts accidentally cause a short circuit.

4. Remove bad cells, loosen and remove terminal screws. Remove washers and terminal links. To remove individual cells, screw terminal screws back into each cell terminal, grasp these screws with pliers and lift the cell straight up.
5. After removing bad cells, prepare jumper from 1 foot of No. 4 AWG and two terminal lugs. Remove 1/2 inch of insulation from one end of wire and crimp terminal lug on stripped end of wire. Measure and cut wire to needed length, strip 1/2 inch of insulation and crimp terminal lug to other end of wire.
6. Install jumper across removed cells in place of terminal links. Cells are connected in series (positive to negative, Figure 11-21).
7. Torque terminal screws (10-32) to 35 to 50 inch-pounds, or terminal screws (8-32) to (20 to 25) inch-pounds. If torque wrench is not available, tighten firmly with wrench or pliers.
8. Replace cover and install battery in aircraft.
9. Record BDAR action taken. When mission is complete, as soon as practical, repair the equipment/system using standard maintenance procedures.

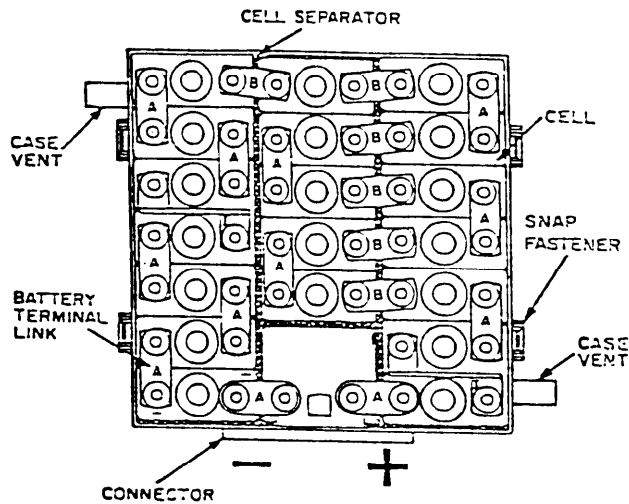

Figure 11-21. Battery, Storage BB-433/A Cell Layout

Section VI. POWER RELAYS

11-24. POWER RELAY TEST AND REPAIR.

GENERAL INFORMATION: Use the following procedures to check power relays for malfunctions.

OPTION 1: Check Power Relay for Malfunction.

LIMITATIONS: None.

PERSONNEL/TIME REQUIRED:

- 1 Soldier
- 5 Minutes

MATERIALS/TOOLS REQUIRED:

- Multimeter (item 229, Sec II, App B)

PROCEDURAL STEPS:

1. Check for 28 V.DC at terminal X1, if voltage is not present, input power wire is open.
2. Check for 0 V.DC at terminal X2. If 0 V.DC is present, it's alright. If 28 V.DC is present, the ground wire is open.

3. If 28 V.DC is present at X2, check for voltage ON A1 & A2, B1 & B2, etc. If voltage is present on A1, but not on A2 (for example), the relay is bad and must be replaced.

OPTION 2: Salvaged Power Relay Installation.

NOTE

Identical P/N or NSN (Figure 11-22) denotes interchangeability. If damage is extensive, salvaged relays may be difficult to attach to bulbheads.

LIMITATIONS: None.

PERSONNEL/TIME REQUIRED:

- 1 Soldier
- 30 Minutes

MATERIALS/TOOLS REQUIRED:

- Salvaged Power Relay

PROCEDURAL STEPS:

1. Obtain salvaged power relay.
2. Disconnect battery.
3. Remove damaged power relay as follows:

NOTE

Note the position of wires/bus bar and what terminals they are connected to.

- a. Remove attaching hardware, wires, and bus bar.
 - b. Remove attachment bolts, and lift relay free from compartment.
4. Position salvaged power relay, and install mounting hardware.
 5. Install wires and bus bar on correct terminals and secure with hardware.

OPTION 3: Creating a Jumper for Damaged Power Relays.

LIMITATIONS: Emergency repair. No control over jumpered power relays, circuit cannot be turned on or off.

CAUTION

- DO not jumper battery relay on any aircraft.
- This procedure is to be used only for one time emergency evacuation and recovery of UH-1 helicopters.

PERSONNEL/TIME REQUIRED:

- 1 Soldier
- 20 Minutes

MATERIALS/TOOLS REQUIRED:

- Wire Repair Kit (item 11, Sec I, App B)
- Appropriate Size Aircraft Type Wire
- Appropriate Size Terminal Lugs

PROCEDURAL STEPS:

1. Disconnect battery.
2. Figure 11-23A and 11-23B, shows two typical power relay configurations with jumper. This may be used as an aid in performing steps 3 thru 7.

NOTE

Use wire with the same gage or larger than the one being replaced.

3. Prepare a jumper wire, (A 1/2 to 1 foot length of appropriate size wire with appropriate size terminal lugs crimped on each end.)
4. Locate terminals marked A1 and A2 on power relay. Power relay terminals should be marked on case of relay. If markings are illegible, A1 and A2 terminals will be the ones with the largest diameter terminal studs.
5. Remove hardware from terminals A1 and A2.
6. Install jumper from terminal A1 to terminal A2. Reference Figures 11-23A and 11-23B.
7. Install hardware on terminals A1 and A2. Tighten hardware to hold jumper in place.
8. Remove jumper as soon as emergency evacuation flight is completed.
9. Record BDAR action taken. When mission is complete, as soon as practical, repair the equipment/system using standard maintenance procedures.

Helicopters Serial No. 66-746 Through 66-17144

<u>DRAWING DESIGNATION</u>	<u>PART NUMBER</u>	<u>FUNCTION</u>
K1	MD24171D1	Relay, Ext. Power
K2	MD24171D1	Relay, Non-Ess Bus
K3	MD24172D1	Relay, Starter
K4	MS24568D1	Relay, Bus Cont. (Gen Fail)
K5	AN3025-300	Relay, Reverse Curr. (Main)
K6	RE200	Relay, Overvoltage
K7	MS25457	Relay, Gen Field
K8	MI LR7611TYPEMA1	Relay, AC Failure
K9	MS24171D1	Relay, Battery
K10	MS24149D1	Relay, Fuel Transfer
K11	MS24149D1	Relay, Lockout Cabin Heater
K15	MS24149D1	Relay, Standby Gen. Field
K22	MS24166D1	Relay, Heater Purging
K23	AN3025-300	Relay, Standby Gen. Rev. Curr.
K24	MS24149D1	Relay, Cargo Hook Release
K27	MS24149D1	Relay, Inverter
K32	MS24171D1	Relay, Hoist Power
K35	MS24166D1	Relay, Main Invtr. Power
K36	MS24166D1	Relay, Spare Invtr. Power
K46	O2A3-12HC2-0030	Relay, Overheat
K65	MS24171D1	Relay, Battery Aft Location
K66	205-075-137-5	Relay, Battery Feeder

Figure 11-22. UH-1H/V Relay Location

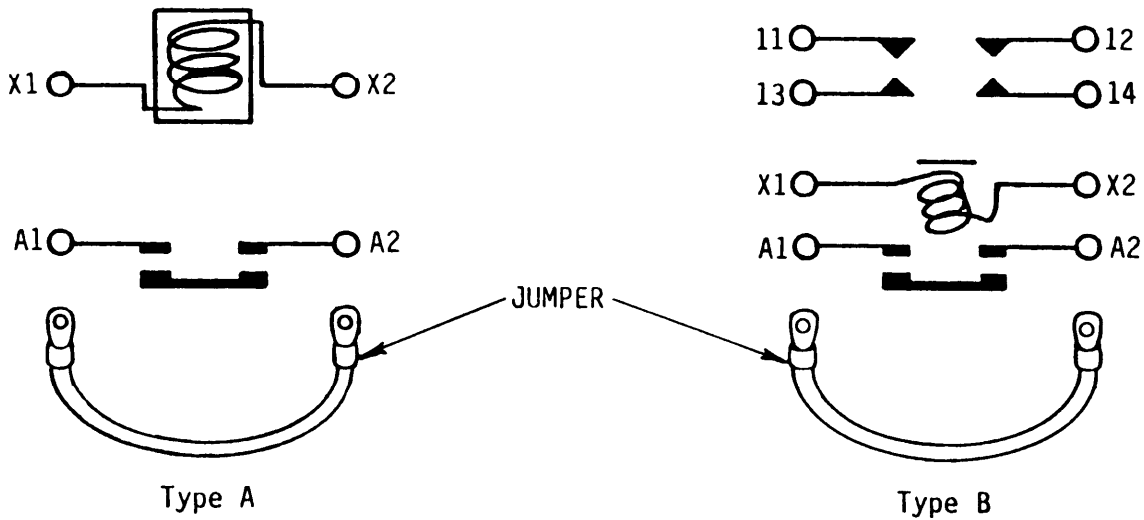

Figure 11-23. Block Diagram, Typical Power Relays

Section VII. ANTENNAS

11-25. GENERAL. This section contains expedient repair procedures to restore lost antenna.

WARNING

Avoid contact with expedient antennas. Bare wires could cause severe burns and electrocution hazard.

11-26. SUBSTITUTE EMERGENCY ANTENNA.

GENERAL INFORMATION: This procedure gives instructions for construction of a replacement antenna that can be used to transmit and receive radio messages on all FM radios on UH-1H/V helicopters.

OPTION: Fabricate Emergency Antenna.

LIMITATIONS: Some loss of antenna gain and radio transmitter power.

PERSONNEL/TIME REQUIRED:

- 1 Soldier
- 1 Hour

MATERIALS/TOOLS REQUIRED:

- Cable, Coax RG-58U or Other Available Coax
- Tape, Elec (or equivalent)
- Resistor, Carbon, 1 Watt 51 Ω \pm 5%
- Wire Repair Kit (item 11, Sec I, App B)

PROCEDURAL STEPS:

1. Determine length of wire needed for the radiating element by using Figure 11-24. Example:

• FM radio with frequency range of 30 to 69.95 MHz.

• Center of frequency range is 50 MHz.

• Using Figure 11-24, look under frequency column for 50 MHz on the wave length side of the Table, 6 M is shown.

• Use Figure 11-24 to convert meters to feet. Six meters multiplied by 3.280 = 19.68 feet for one wave length.

• Divide the one wave length by 8, for a 1/8 wave length antenna, $\frac{19.68}{8} = 2.46$ feet. Multiply the 1/8 wave length by a 0.95 correction factor: 2.46 ft. X 0.95 = 2.34 feet. This is the length of the radiating element.

2. Cut the coax cable to the length of the required radiating element. Remove the outer insulation and shield from the piece of coax cable and then strip a 1 inch piece of insulation from each end exposing the center conductor, Figure 11-25.

3. Wrap and solder the 51 Ω resistor to one end of the radiating antenna element as per Figure 11-25. This completes the fabrication of the emergency antenna.

4. Next, open the access panel door on the right-hand side just forward of the tail boom, Figure 11-26. The location of antenna coax lead may be found on other location of aircraft. The emergency antenna is a generic fix for FM radios ARC-54, ARC-131, and ARC-114.

5. At the tail boom quick disconnect, locate coax cable marked ARC 114-105A and disconnect it.

6. Cut the coax connector off the antenna coax and prepare a 4 inch pigtail termination on the end of the coax cable as shown in Figure 11-27.

7. Pass the radiating element of the antenna, from step three, with the resistor end down into the drain hole in the bottom of the tail boom where it joins the fuselage, Figure 11-26.

8. Twist join the center conductor from the radiating element of the antenna to the center conductor of the coax. Make a good mechanical joint and insulate with tape.

Frequency Wavelength

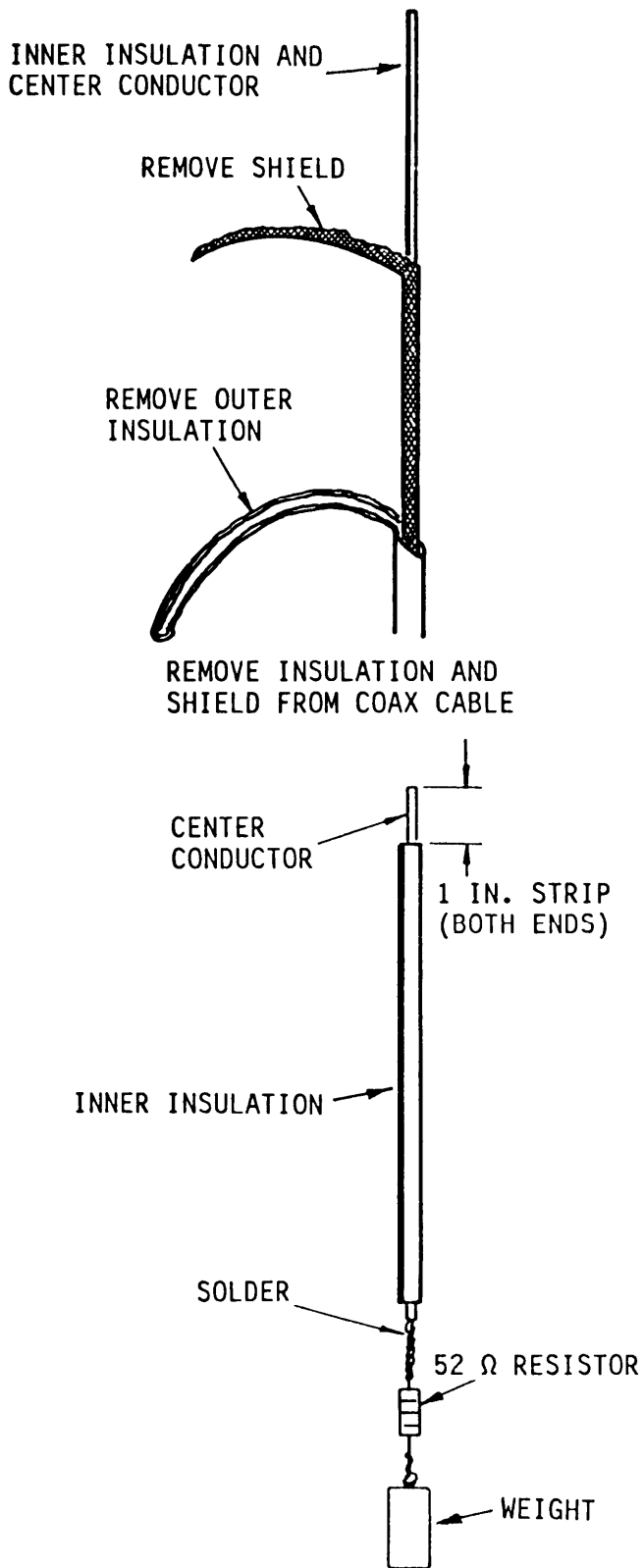
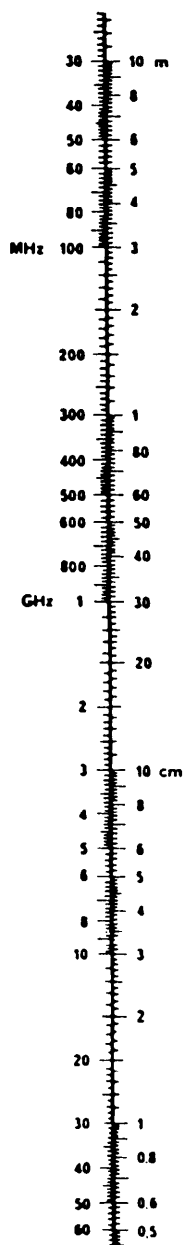
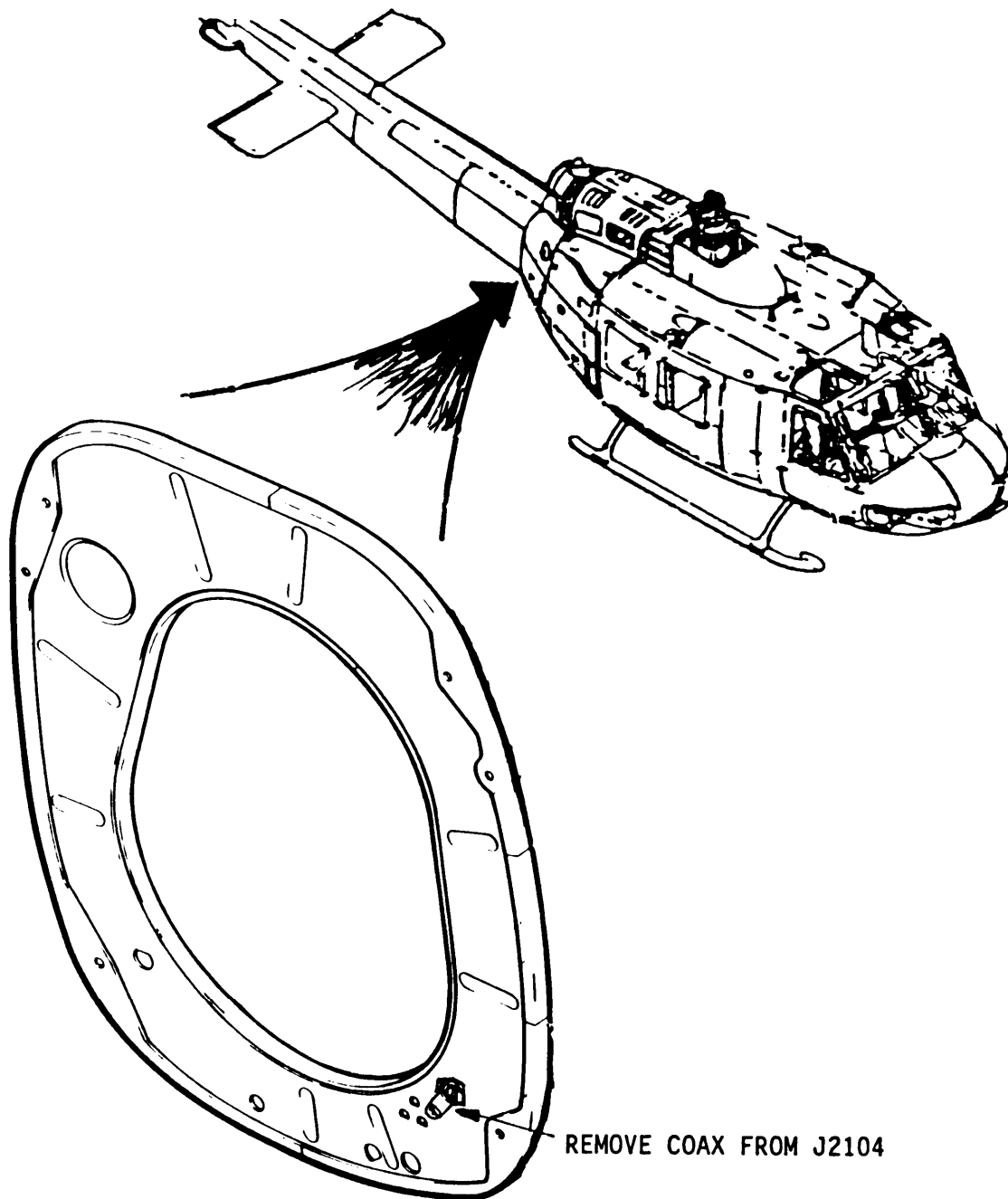

Figure 11-25. Fabrication of Emergency Antenna

Figure 11-24. Frequency vs. Wave Length

TO CHANGE	TO	MULTIPLY BY
Centimeters . . .	Inches	0.394
Meters	Feet	3.280



ARC 114-105A ANTENNA COAX SHOWN.
LOCATION OF ANOTHER LATER MODEL
CONFIGURATION COAX WILL BE FOUND
UNDER CREW CABIN ROOF.

Figure 11-26. Installation of Field Expedient Antenna

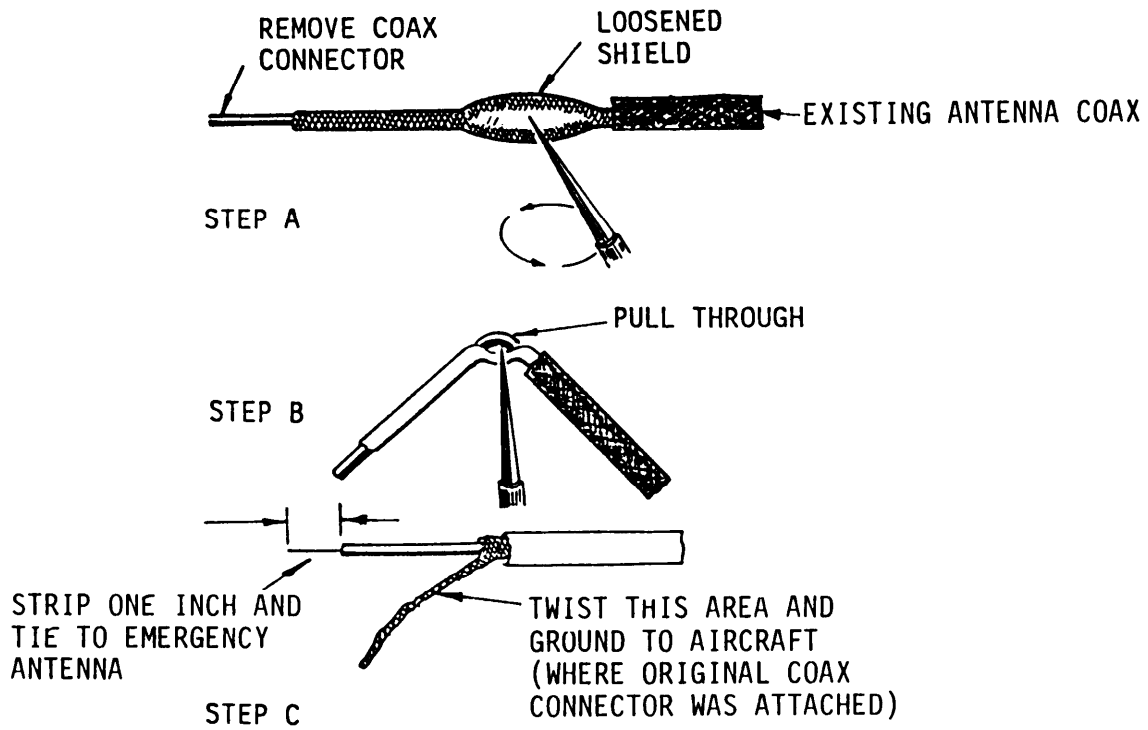

Figure 11-27. Pigtail Termination for Shielded Wire

9. Ground the pigtail from the coax antenna by wrapping and twisting it around the plug where the coax was disconnected. A ground strap at the bottom of the bulkhead, Figure 11-26.

10. Secure with tape to hold the antenna and coax in place inside the tail boom. Let the antenna dangle free through bottom of helicopter.

11. Solder a one to two ounce weight, below the 51 Ω resistor as shown in Figure 11-25 to make it hang down.

12. Record BDAR action taken. When mission is complete, as soon as practical, repair the equipment/system using standard maintenance procedures.

NOTE

Antenna must be at right angle (90°) to aircraft skin to radiate R.F. energy. Do not tape antenna to skin of aircraft.

CHAPTER 12

FUEL SYSTEM

BDAR FIXES SHALL BE USED ONLY IN COMBAT OR FOR TRAINING AT THE DISCRETION OF THE COMMANDER. (AUTHORIZED TRAINING FIXES ARE LISTED IN APPENDIX E.) IN EITHER CASE, DAMAGES SHALL BE REPAIRED BY STANDARD PROCEDURES AS SOON AS PRACTICABLE.

Section I. INTRODUCTION

12-1. SCOPE.

a. The fielded UH-1H/V is equipped with a crashworthy fuel system which is designed to resist fuel spillage and reduce fire hazards. It incorporates self-sealing tanks and self-sealing breakaway valves in the fuel supply and vent lines, Figure 12-1. Breakaway fittings are designed to break between self-closing valves if a crash occurs. The fuel supply consists of five interconnected cells which act as a single tank, Figure 12-1. Three cells are located below the engine deck with the filler cap on the right cell. The two forward cells are located under the cabin deck and are gravity fed from the aft cells. Both forward fuel cell sump assemblies contain electrically or pneumatic driven boost pumps.

b. Fuel is delivered under pressure from the pump to a check valve manifold on the front of the engine forward firewall out through an electrically controlled shut-off valve to the main fuel filter then to the engine at the fuel control. The fuel shut-off valve and the check valves in the manifold have internal bypasses to relieve pressure produced by thermal expansion of trapped fuel when the system is inoperative. The fuel pressure transmitter is attached to the check valve manifold. Figure 12-1 shows a perspective layout of the fuel system. Figure 12-2 is a schematic flow diagram.

c. Self-sealing fuel cells which have a 50 caliber ballistic protection level seal by the swelling of the sealant when exposed to fuel. When the projectile penetrates the cell wall, the fuel causes the sealant to swell closing the damage hole.

d. Because the fuel cells are interconnected if one of the fuel cells, drain valves, or interconnect lines is damaged and cannot self-seal, all the fuel in both the forward and aft cells may eventually leak out. BDAR fixes to this area are generally confined to component replacement, expedient line repairs, or isolating damaged subsystems. Damage to fuel systems may require refueling to replace fuel lost by leaks and/or defueling.

e. If a fuel system component such as a fuel cell, pump, module, valve, etc. is damaged and component still operates satisfactorily and does not leak, repair may be deferred. The component, however, should be inspected after every flight to assure that operation has not been degraded or that a leak has not developed.

f. Fuel system hoses and tubes. If leaks develop as a result of such damage and time and resources are not available for standard repair procedures, use the BDAR fixes in this TM.

TM 55-1520-210-BD
FUEL SYSTEM

1. Boost Pump
2. Gravity Feed Lines
3. Main Fuel Filter
4. Pressure Transmitter, Fuel
5. Check Valve Manifold
6. Flange
7. Fuel Shut-Off Valve
8. Elbow
9. Drain Valve
10. Fuel Quantity Transmitter
11. Low Level Float Switch
12. Filler Cap

NOTE: CONNECTING NIPPLES NOT SHOWN

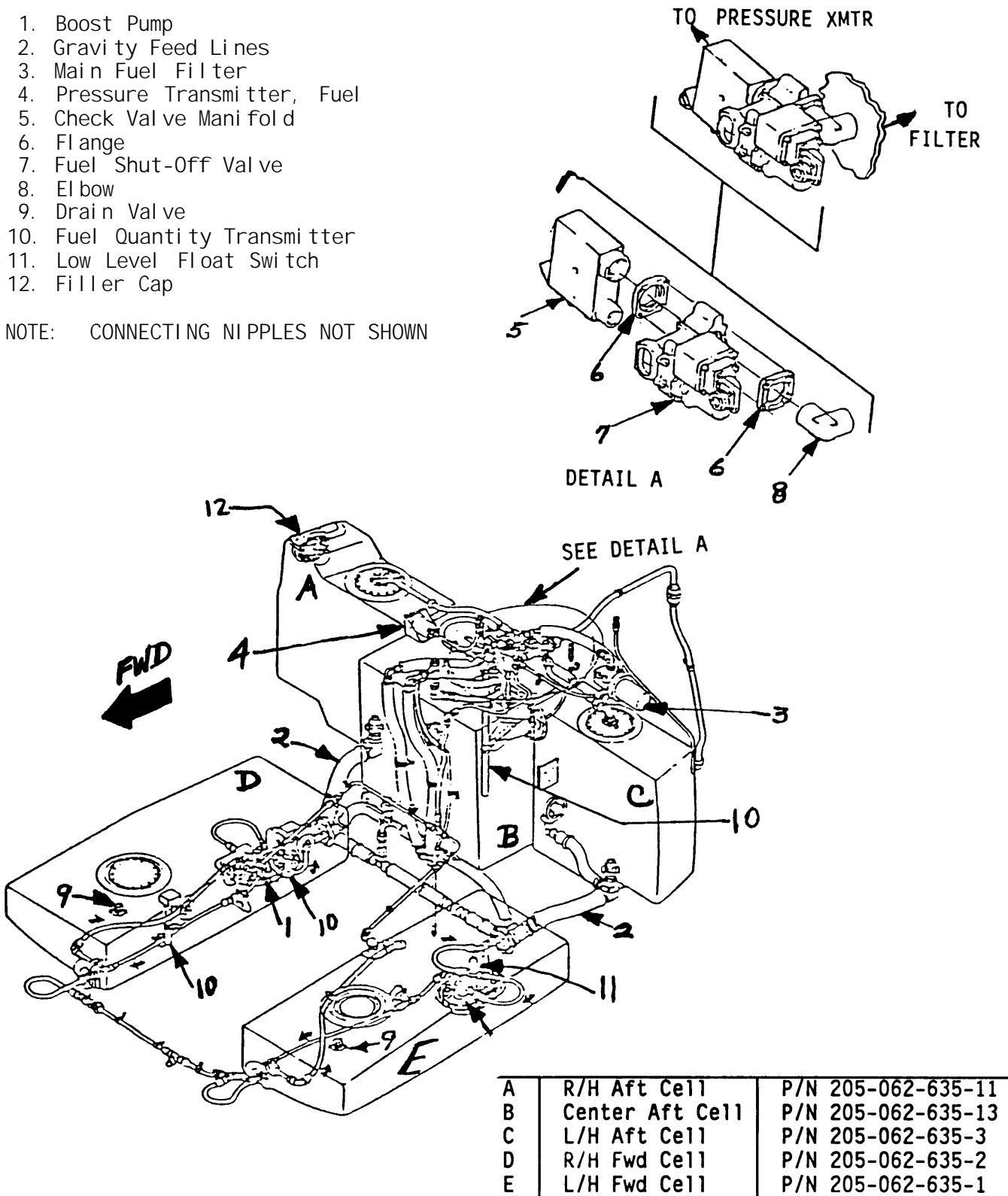

Figure 12-1. Fuel Cell Installation - Crashworthy

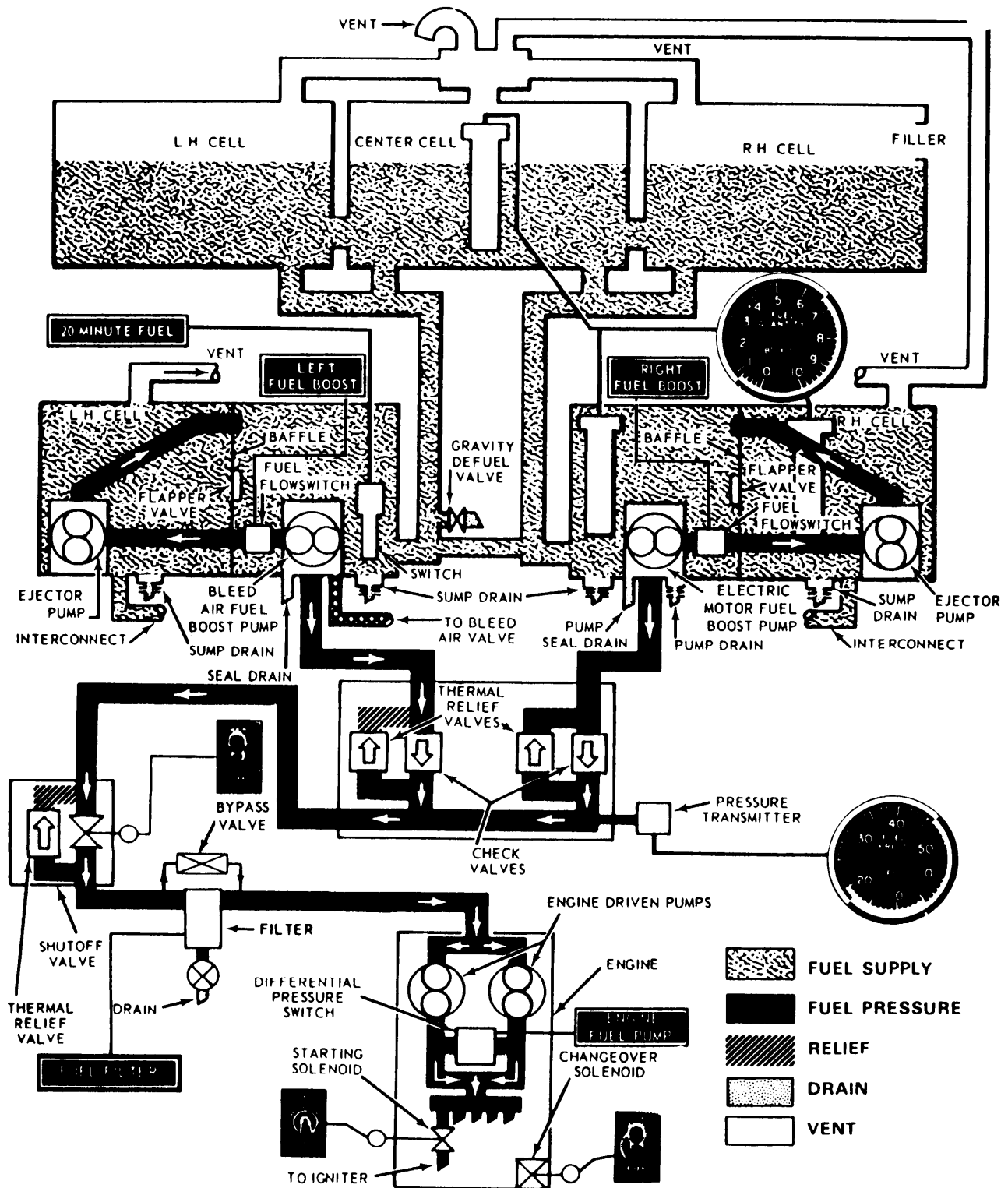

Figure 12-2. Fuel System Schematic

12-2. **ASSESSMENT PROCEDURES.** No specific assessment procedure is needed to locate damage fuel cells, components, or leaking fuel lines. Use Figures 12-1, 12-2 and 12-3 to guide you in locating and identifying damaged areas and leaks. The replacement of damage components should be per TM 55-1520-210-23.

12-3. **REPAIR PROCEDURE INDEX.**

	<u>PARA.</u>
Fuel Line Replacement	12-4
Metal Tube Replacement.	12-4
Hose Replacement.	12-4
Metal Tube Repairs.	12-5
Hose Repairs.	12-6
Fuel Cell Replacement	12-7
Fuel Cell Isolation & Bypass.	12-8
Fuel Cell Repairs	12-9
Fuel Filter Bypass.	12-10

Table 12-1. Assessment Procedures

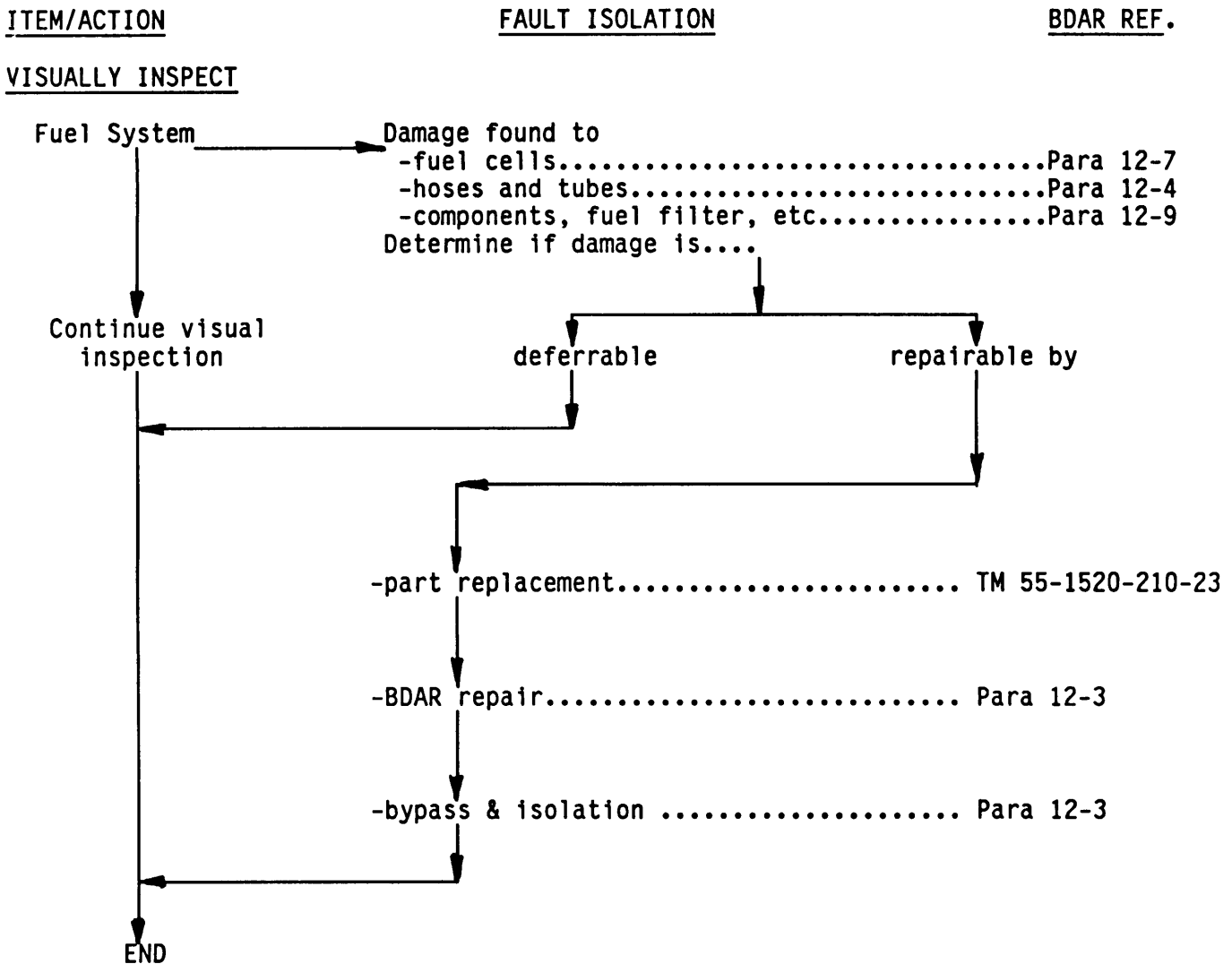

Section II. FUEL LINES

12-4. GENERAL.

a. Fuel Lines.

(1) Replacement fuel lines need not be routed along the path of the original installation. They may be routed along any convenient path as long as they do not interfere with personnel or with operating equipment. Long lines and hoses should be clamped or fastened with tape to hard supports at convenient intervals not exceeding two feet.

(2) Fuel system metal tubes and rubber hoses.

(a) All the fuel system tubes and hoses on the UH-1, their sizes, and lengths are identified by item number in Figure 12-3.

(b) Damaged tubes will normally be replaced with hose assemblies from BDAR kit or with a salvaged/cannibalized tube of same I.D. The length can be longer.

(c) If hose assemblies from BDAR kits are not available, damage may be cut out and replaced with a small section as shown by BDAR repairs (refer to repair procedures), or a replacement hose may be manufactured if a long enough hose section and MS fittings are available (refer to repair procedures in TM 55-1520-210-23).

(d) Never discard MS fittings, they are reusable. The MS21922 sleeve is not reusable.

12-5. METAL TUBING, DAMAGED.

OPTION 1: Rubber Hose Coupling and Hose Clamps Repair, Figure 12-4.

LIMITATIONS: None.

PERSONNEL/TIME REQUIRED:

• 1 Soldier
• 1 Hour

MATERIALS/TOOLS REQUIRED:

- Safety Wire or Equivalent (items 73-75, App C)
- 4 Hose Clamps AN737 (items 37-42, App C)
- 5-Minute Epoxy Sealant (item 4, App C)
- Fluid Line Repair Kit (item 4, Sec I, App B) Hose

PROCEDURAL STEPS:

1. Cut and remove damaged area of metal tube.
2. This step is optional. If time permits, make an improvised bead as shown in Figure 12-4 by wrapping wire around the metal tube four to eight turns. Coat the wire with epoxy and let cure 5 to 10 minutes. Make the epoxy bead as smooth as possible.
3. Select a piece of rubber hose that will fit snug to tight over the tubing ends. Cut to length so that it will extend 1-1/2 to 2 inches over tubing ends.
4. Apply 5-minute epoxy adhesive on the tube ends being careful not to contaminate the inside of fuel line, Figure 12-4. Quickly push rubber hose on ends of tube and secure with four (each) hose clamps. Let joints cure 10 minutes.
5. Record BDAR action taken. When mission is complete, as soon as practical, repair the equipment/system using standard maintenance procedures.

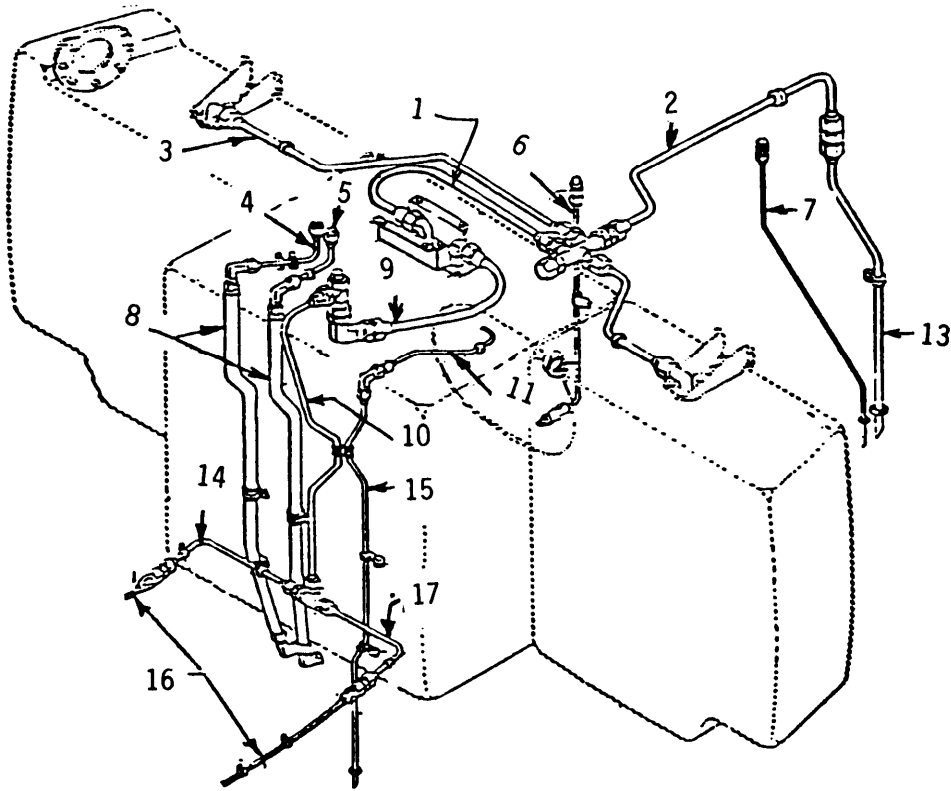

INDEX	PIN	NOMENCLATURE	NOM OD	WALL THICKNESS	MIN LENGTH
15	205-060-690-1	Tube Assy ¹	3/8	0.035	46.0
17	205-062-662-1	Tube Assy ¹	3/8	0.035	9.0
14	205-062-663-1	Tube Assy ¹	3/8	0.035	30.0
8	205-062-650-9	Hose Assy ³	1070		33.7
10	MS87028H280C	Hose Assy ²	1/2	0.062	28.0
11	205-061-655-1	Tube Assy ¹	3/8	0.035	28.0
9	MS87028K146A	Hose Assy ²	3/4	0.067	14.7
4	205-062-650-13	Hose Assy ³	1.70		15.3
5	205-062-650-11	Hose Assy ³	1.70		14.1
1	MS87028K214A	Hose Assy ²	3/4	0.067	21.5
3	MS87028K292A	Hose Assy ²	3/4	0.067	29.2
2	205-060-695-1	Tube Assy ²	1	0.035	38.0
12	MS87028E216A	Hose Assy ²	1/4	0.031	21.7
7	205-060-697-1	Tube Assy	3/8	0.035	49.0
16	MS8000G180C	Hose Assy	3/8	0.040	18.0
13	205-060-696-1	Tube Assy	1	0.035	35.5
6	205-060-696-1	Tube Assy	1	0.035	35.5

1. Tube = AL alloy 5052-0
 2. Hose = Rubber MIL-H-83797
 3. Hose = Self-sealing (crashworthy) coated hose

Figure 12-3. Fuel System Hose/Tube Installation (Sheet 1 of 4)

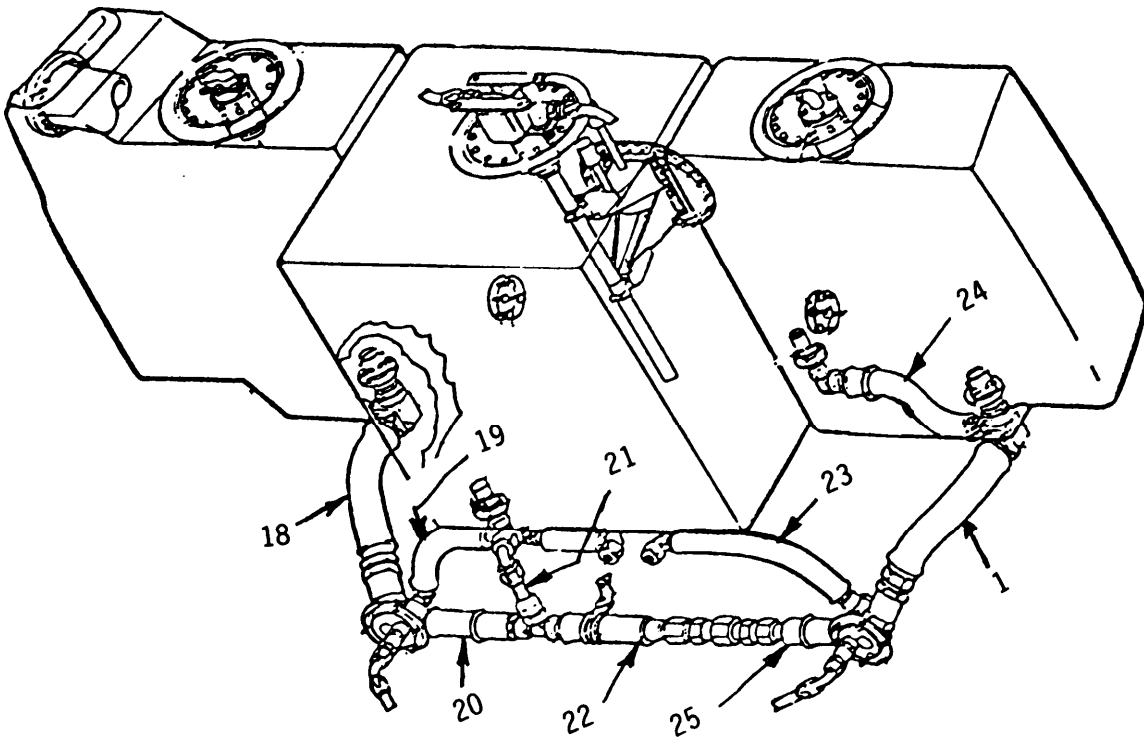

INDEX	PIN	NOMENCLATURE	NOM OD	MIN LENGTH
24	205-062-698-1	Hose Assy ³	3/4	14.3
21	70-010L000G056	Hose Assy	3/4	5.7
18	205-062-698-3	Hose Assy ³ 1	1/4	12.6
19	205-062-650-1	Hose Assy ³	1.70	22.2
23	205-062-650-5	Hose Assy ³	1070	16.5
25	205-062-697-1	Hose Assy ³	3/4	12.1
22	205-062-650-3	Hose Assy ³	1.85	11.5
20	205-062-697-3	Hose Assy ³	3/4	9.0

1. Tube = AL alloy 5052-0
2. Hose = Rubber MIL-H-83797
3. Hose = Self-sealing (crashworthy) coated hose

Figure 12-3. Fuel System Hose/Tube Installation (Sheet 2 of 4)

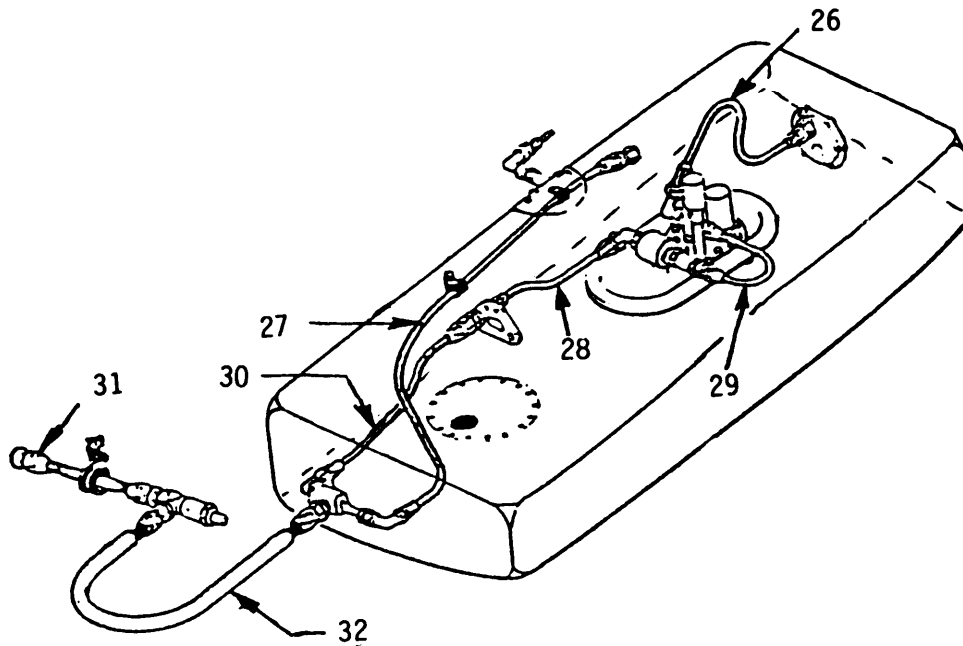

INDEX	PIN	NOMENCLATURE	NOM OD	WALL THICKNESS	MIN LENGTH
31	MS87028H090A	Hose Assy	1/2	0.062	9.0
32	205-062-666-1	Hose Assy	1/2		20.7
27	MS87028J336C	Hose Assy	5/8	0.063	33.7
30	646121-6D0280	Hose Assy	.55	0.210	28.0
29	MS8000G070C	Hose Assy	3/8	0.040	7.0
28	MS8000G130A	Hose Assy	3/8	0.040	13.0
26	MS87028H110C	Hose Assy	1/2	0.062	11.0
33*	205-061-668-1	Tube Assy	1/2	0.035	12.0

*Under tank, not shown

Figure 12-3. Fuel System Hose/Tube Installation (Sheet 3 of 4)

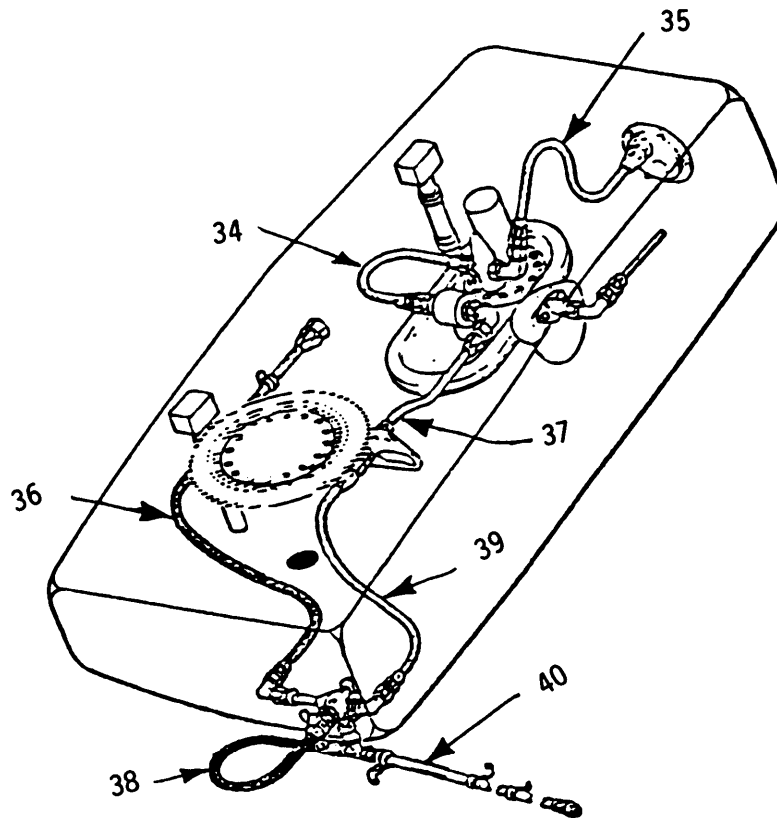

INDEX	PIN	NOMENCLATURE	NOM OD	WALL THICKNESS	MIN LENGTH
40	MS87028H175A	Hose Assy	1/2	0.062	17 5/8
38	205-062-666-1	Hose Assy	1/2	-	20.7
36	MS87028J336C	Hose Assy	5/8	0.063	33.7
39	646121-6D0280	Hose Assy	3/8		28.0
37	MS8000G090C	Hose Assy	3/8	0.040	9.0
34	MS8000G130A	Hose Assy	3/8	0.040	13.0
35	MS87028H110C	Hose Assy	1/2	0.062	11.0

Figure 12-3. Fuel System Hose/Tube Installation (Sheet 4 of 4)

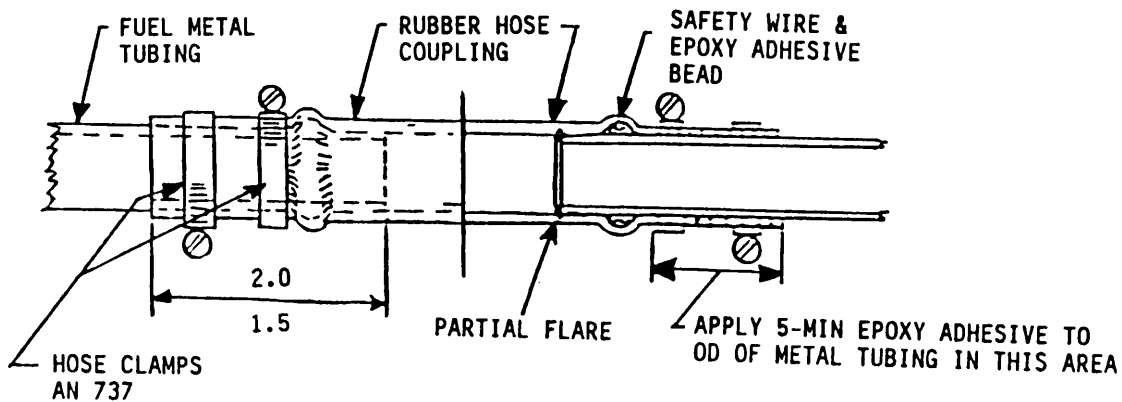

Figure 12-4. Hose and Clamp Fuel Tubing Repair

OPTION 2: Metal tubing; long damaged sections can be replaced with a metal tube spliced in place at both ends by two rubber hose external couplings. Use the procedural steps in option 1 to install these two couplings. Also, see Figure 12-4.

OPTION 3: Metal tubing; small hole damage can be repaired as follows:

LIMITATIONS: None.

PERSONNEL/TIME REQUIRED:

- 1 Soldier
- 30 Minutes

MATERIALS/TOOLS REQUIRED:

- Adhesive (item 4, App C)
- Hose Clamps (item 37-42, App C)
- Hose Piece or Other Rubber Patch Material (items 115-117, App C)
- Sheet Metal, 1/32 Aluminum (item 131, App C)

PROCEDURAL STEPS:

1. Use a piece of rubber hose or other hard rubber material, and cut a patch to fit over the hole. The patch should be as large as possible. If a piece of hose is used, cut it lengthwise.

2. Place the patch centered over the hole. If a piece of hose is used, install the hose over the hole with the split opposite the hole.

3. Place a hose clamp over the patch, center it and secure in place tightly. The hose clamp band width should be twice as wide as the hole. If hole is very large, apply a piece of 1/32 aluminum sheet metal over the rubber patch. Use either one or two hose clamps to secure tightly in place.

4. Five minute adhesive epoxy can be used to adhere rubber patch and sheet metal backup. Clean area to be joined with solvent cleaner.

5. Record BDAR action taken. When mission is complete, as soon as practical, repair the equipment/system using standard maintenance procedures.

12-6. RUBBER HOSE, DAMAGED. All high pressure hose repairs will be repaired by replacing per TM 55-1520-210-23. Fluid line repair kit (item 4, Sec I, App B) will be used to make up repair lines.

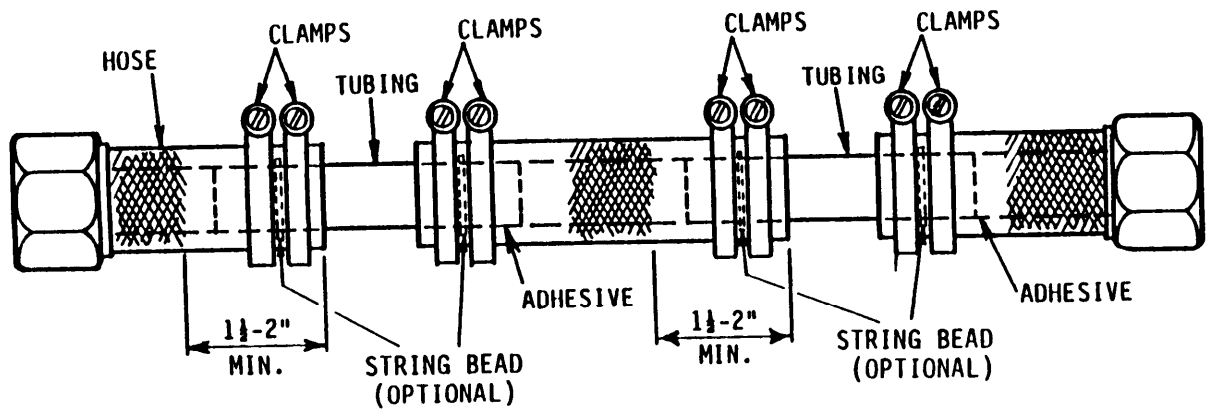
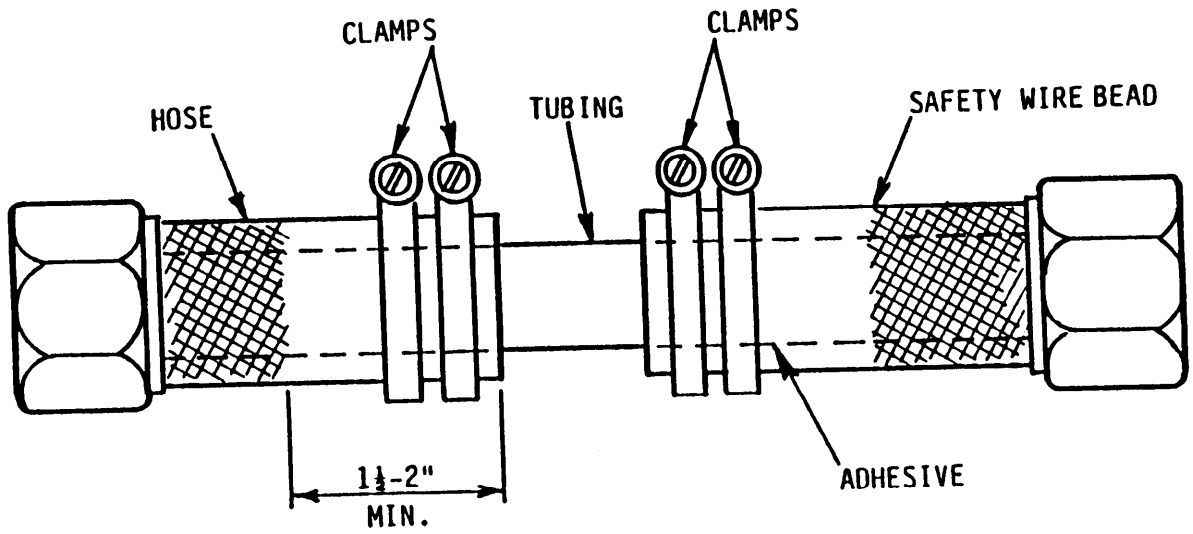

Figure 12-5. Damaged Hose Repair

Section III. FUEL CELLS

12-7. GENERAL.

a. The BDAR helicopter repairs listed in this section are for repairing leaks that go beyond the self-sealing capability of crashworthy fuel cells and/or to isolate and bypass damaged fuel cells. The repairs are given in time to accomplish the repair, but not the time required to gain access to the damaged area.

b. Because of the size, location, plumbing connections and the specific fuel cell affected, the time to gain access to the damaged area can vary considerably. The trained assessor will determine if the conditions warrant deferring the repair, bypassing the damaged fuel cell, or repairing. It is not the intent of this section to detail the steps in gaining access to the fuel cell repair area. Information on skin, panels and structure removal can be found in TM 55-1520-210-23 and TM 55-1500-204-25/1.

c. The BDAR repairs may limit or restrict the operational capability of the helicopter to a one-time flight, mission completion flight, or self-recovery flight. Further, the repairs specified will not necessarily return the tanks to their original self-sealing and crash resistant level.

d. The UH-1 crashworthy fuel cells are designed to resist catastrophic fuel loss in case of a crash. They are also self-sealing to penetration damage of a normal (nontumbling) 0.50 caliber API or smaller projectile.

e. Damage caused by a fully tumbled 0.50 caliber projectile or any other cause which will leave a damaged area 1 X 3 inches in rectangular area (or exceeds this area) is not allowed.

12-8. FUEL CELL, DAMAGED BEYOND REPAIR. If a fuel cell is severely battle damaged and there is no replacement for it, then alterations should be made to the system to isolate and bypass the damaged cell. For other repairs to fuel cells, see paragraph 12-3, repair procedure index.

LIMITATIONS:

1. The helicopter's center of gravity may be changed after the removal/isolation of any one or more of the fuel cells due to non-symmetry and unbalanced fuel load. See Table 12-2 and Figure 12-6. Also, consult TM 55-1520-210-10, UH-1H/V Helicopter Operator's Manual.
2. The fuel supply will be reduced, Table 12-2.
3. The pilot must adjust mission configuration equipment according to existing mission needs and overall helicopter flight degradation.

PERSONNEL/TIME REQUIRED:

- 2 Soldiers
- 3 Hours

MATERIALS/TOOLS REQUIRED:

- Bolt (item 14, App C) & Nut (item 77, App C)
- Bolt (item 15, App C) & Self-Lock Nut (item 84, App C)
- Cap Fitting (item 4, Sec I, App B)
- Drill Motor & Drill Bit Set (item 67, 69, Sec II, App B)
- Knife and Scissors (item 118, 161, Sec II, App B)
- Rubber Gasket Material (item 117, App C)
- Sealant (item 10, App C)
- Washer, Flat (item 168, App C)

PROCEDURAL STEPS:

1. Defuel the helicopter's fuel system per paragraph 12-9, procedural step No. 1.

Table 12-2 Weight & Balance Computation Data for Fuel Cells

FUEL CELL	APPROX QTY US GAL	APPROX AREA TANK BOTTOM SQ IN	APPROX WT JP4 LBS	APPROX STA CTR OF CELL	APPROX LONGITUDINAL MOMENT 1100	APPROX LATERAL MOMENT 1100
R/H Fwd	38.5	1242	250	130	325	63
L/H Fwd	38.5	1242	250	130	325	63
R/H Aft	32.5	304	211	177	373	57
L/H Aft	32.5	304	211	177	373	57
Ctr Aft	64	588	416	168	699	0
TOTAL	206.0		1338			

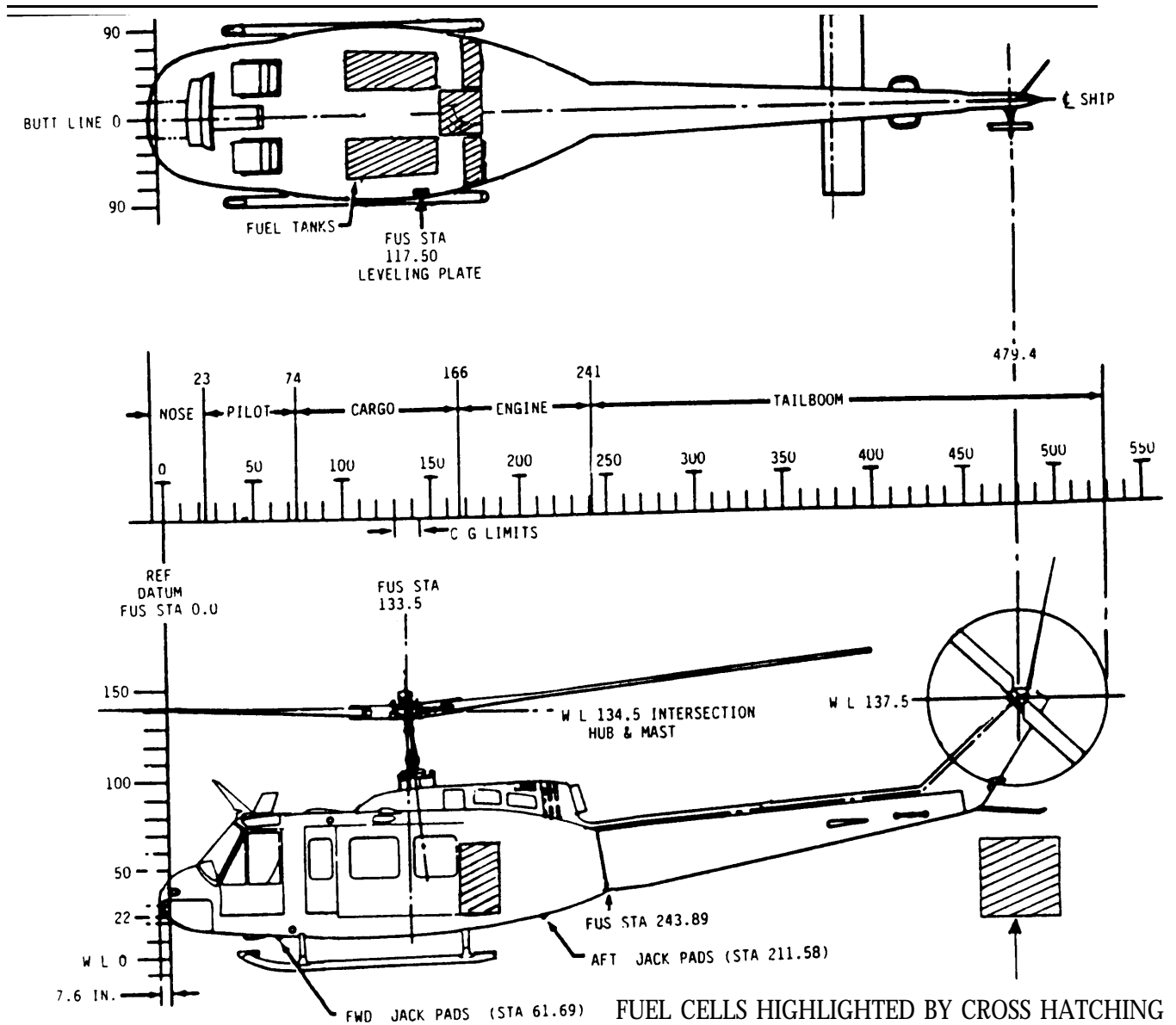

Figure 12-6. Fuel Cell Location and Approximate Arm as Compared with Center of Gravity

TM 55-1520-210-BD
FUEL SYSTEM

2. Remove access panels as necessary to gain access to the crossover lines, and the top or the cells.

3. Isolate fuel cell A or C of Figure 12-7 as follows. Procedures are listed for cell A and are the same for cell C.

a. Blocking Off Hose (3), Flange (2).

(1) Remove four screws (1) from hose adapter flange (2) of the gravity feed hose (3) which is connected to check valve (4).

(2) Fabricate cover (5) from a piece of sheet metal or other plate material to fit over the face of adapter flange (2), Figure 12-7.

(3) Drill four holes 1/4 inch diameter to match holes in adapter flange (2). See detail C.

(4) Make a gasket (6) from rubber material or from the isolated cell to the same size as the flange (2) and Cover (5). Punch, drill, or cut holes for the bolts.

(5) If available, apply fuel resistant adhesive sealant between rubber gasket (6) and facing adapter flange (2).

(6) Position bolts of sufficient length to reach through flange (2) and (5). Place rubber gasket (6) on bolts (7). Place cover on bolts (7).

(7) Secure with four flat washers (8), four lockwashers (9), and four nuts (10). A locknut may be used. Torque to 20-30 inch-pounds. Secure the hose with adhesive tape to a fixed object so as to prevent it from bouncing around.

b. Blocking Off Crossover Port (11).

(1) Gain access to the crossfeed port (11) through the center cell (cell B) aft access cover (17) by removing 24 bolts and washers (18, 19), and removing access cover (17).

(2) Remove four bolts (16) from crossfeed port (11).

(3) Make a cover (12) for the crossfeed port (11) in accordance with Figure 12-7, detail B.

(4) Make a gasket (13) from rubber material or from the isolated cell to the same size as the cover (12) as per Figure 12-7, detail B.

(5) If available, apply fuel resistant adhesive sealant to both sides of rubber gasket (13).

(6) Position lockwashers (15), then flat washers (14) on the bolts (16) of sufficient length to ensure a minimum of three full threads of contact in nuts or threads.

(7) Place bolts through holes in cover (12). Place rubber gasket (12) on bolts (16).

(8) Position over crossfeed port (11) and tighten bolts to 20-30 inch-pounds.

(9) Replace access cover (17) with 16 bolts and washers (18, 19).

(10) Refuel aircraft.

NOTE

Refueling must be accomplished slowly to allow cell C to fill through the gravity feed lines.

c. Blocking and Isolating Cell B. See Figure 12-8 for index numbers.

(1) Disconnect the No. 12 B-nut hose fitting (1) from both gravity feed lines (2). See detail A, Figure 12-8.

(2) Plug hose fitting with a 12 AN plug fitting.

(3) Blocking of both crossover ports will be accomplished by paragraph 12-8, procedural step 3 (b).

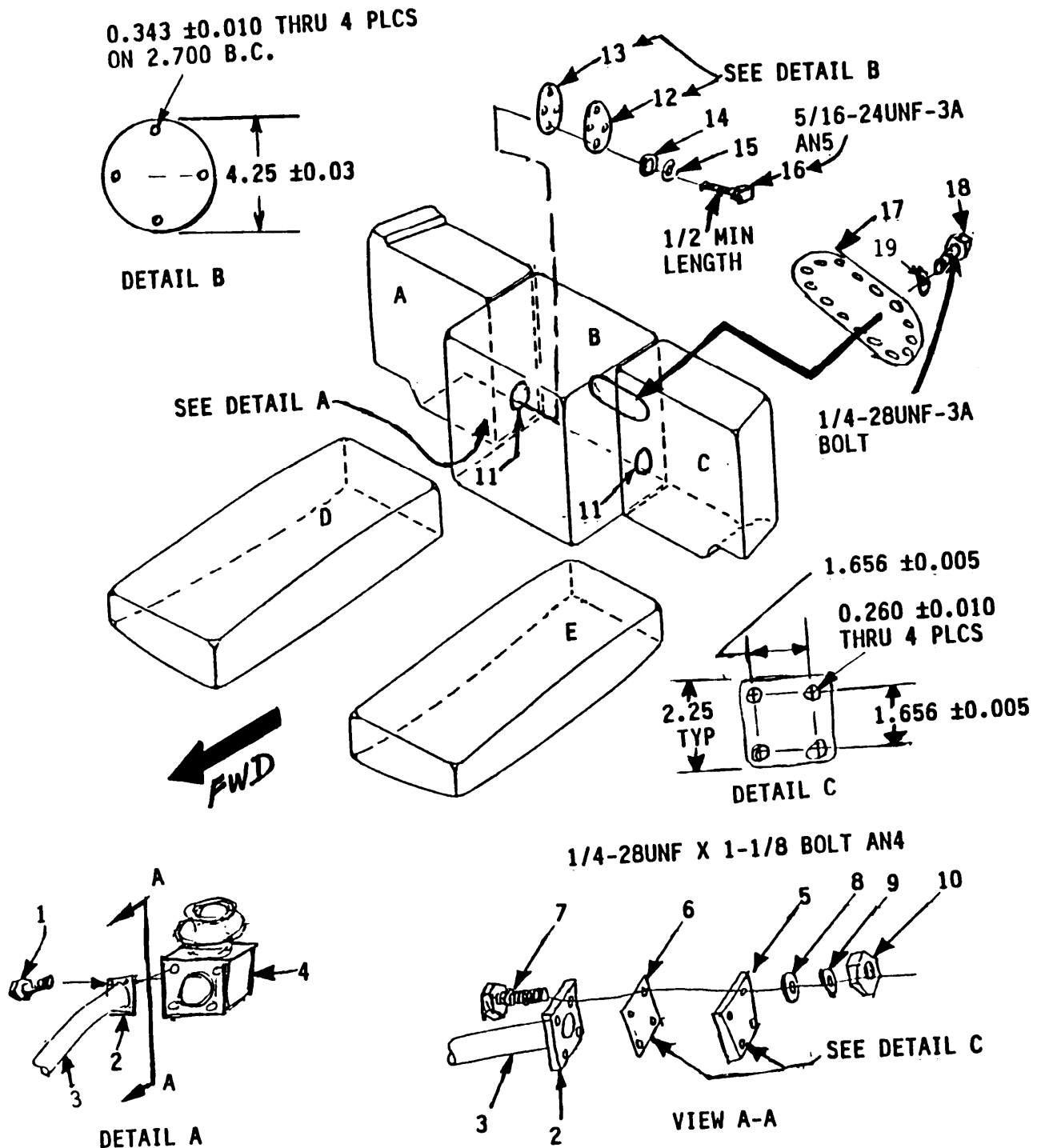

Figure 12-7. Isolation of Cell I A

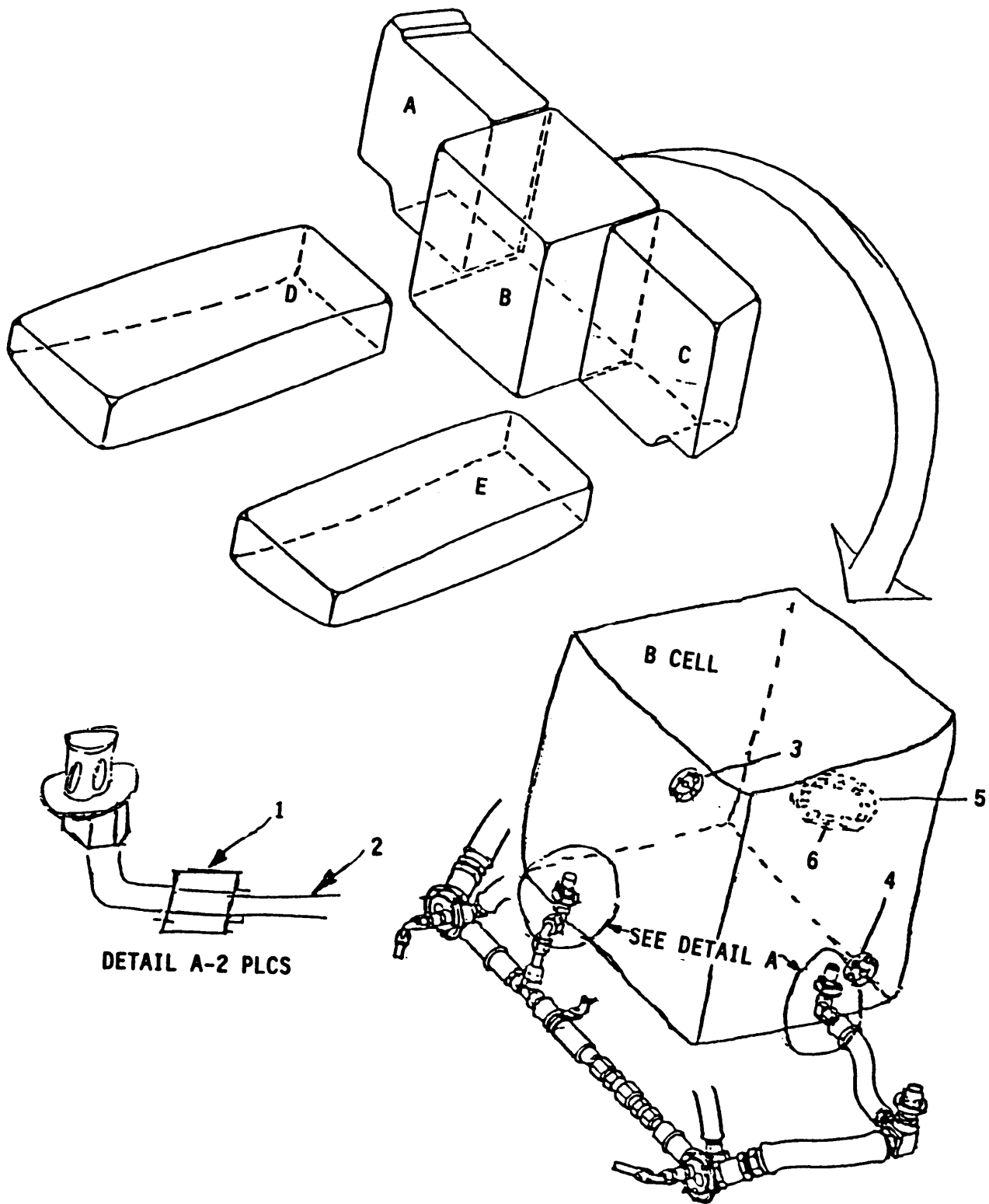

Figure 12-8. Isolation of Cell B

NOTE

When center cell B (Figure 12-8) is isolated, fuel quantity indicator will not be accurate until total fuel load is contained in forward cells.

5. Isolation of cell D or E. See Figure 12-9.

a. Procedures given are for cell E, but cell D uses same procedures.

b. Disconnect fuel pressure line (23) from fuel manifold (Z). Plug end of hose with No. 10 AN plug and MS29512 packing.

c. Disconnect gravity feed hose (2) at crashworthy breakaway valve (W). Remove crashworthy breakaway valve (W) from fuel manifold (Z).

d. Disconnect crossfeed hose (25) from fuel manifold (Z).

e. Remove manifold from tank by removing 12 bolts and washers and disconnecting pump line (Y) from inside of manifold.

NOTE

If breakaway valve (W) is good, it may be reused to help couple gravity feed and crossfeed lines together.

f. Use adapters to reduce feed hose (2) (No. 20 fitting-female) to hose (25) (No. 12 fitting-female). Use proper size M29512 packing in each connection.

g. Disconnect boost pump electrical connection, and pull circuit breaker for that pump-tag circuit breaker "DO NOT RESET THIS BREAKER."

h. Refuel helicopter.

6. Record BDAR action taken. When mission is complete, as soon as practical, repair the equipment/system using standard maintenance procedures.

12-9. FUEL CELL, LEAKING, DAMAGE UP TO 3 X 1 INCH AREA.

OPTION 1: Mechanical Clamp, Figure 12-11.

LIMITATIONS: Emergency one time flight repair. Repair limited to a flat area of cell.

PERSONNEL/TIME REQUIRED:

- 1 Soldier
- 30 Minutes

MATERIALS/TOOLS REQUIRED:

- Mechanical Clamps (items 43, 44, App C)
- Fluid Line Repair Kit (item 4, Sec I, App B)

PROCEDURAL STEPS:

CAUTION

Ground aircraft during defueling and fueling procedures.

1. Defuel aircraft using one or more of the following procedures as necessary to evaluate the cell/cells being worked.

a. Defueling may be accomplished by disconnecting inlet to fuel control (Figure 12-10) and using fuel boost pumps to pump out fuel or

b. opening gravity defuel valves located on sumps adjacent to pump drain valves (1, Figure 12-1). The defuel valve is activated by using a fitting such as AN815-12 union, AN832-12 union, AN9190-12 reducer, and MS33656E12 end fitting after removing protection cover, and

c. drain trapped fuel at drain valves (1 and 9, Figure 12-1).

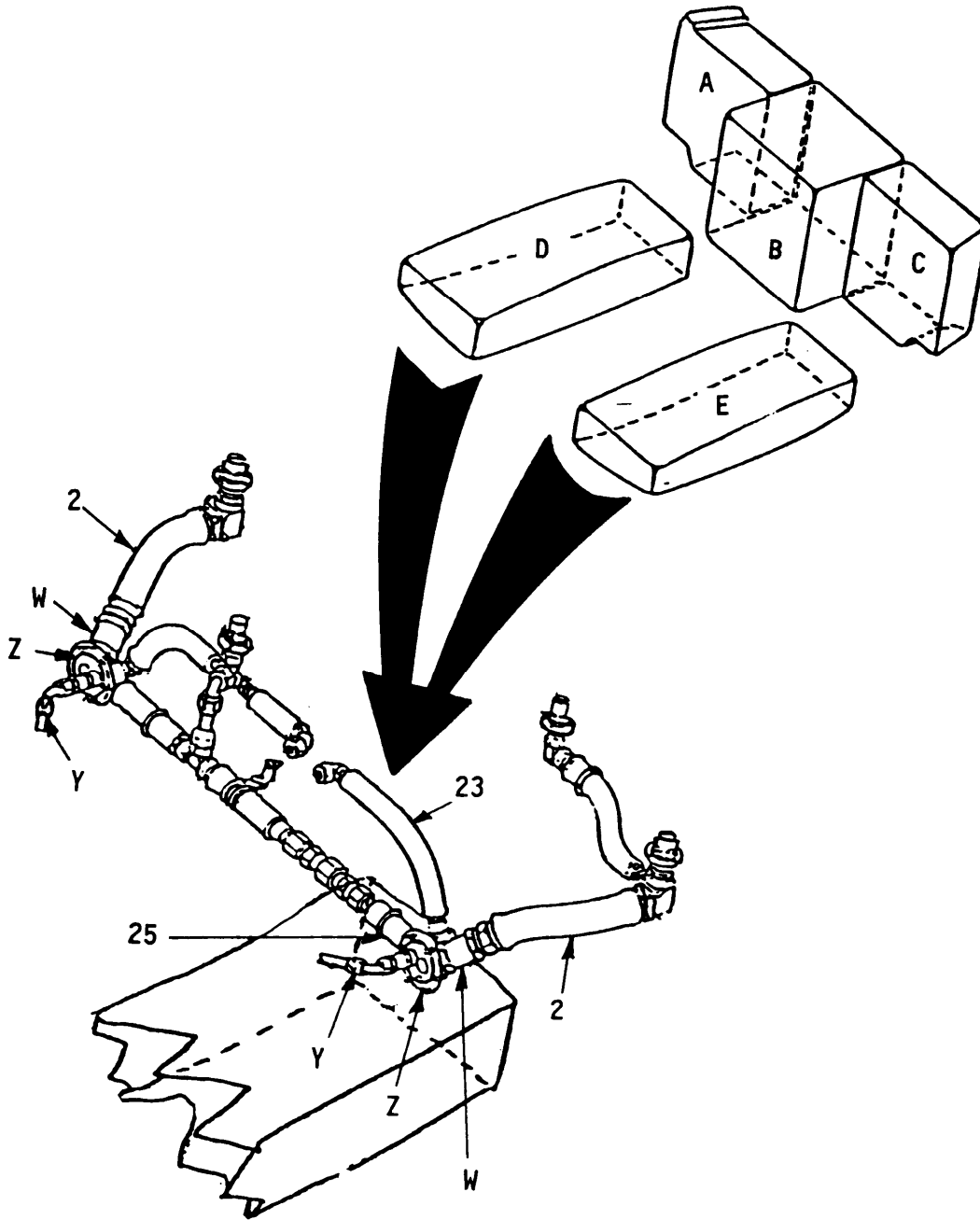

Figure 12-9. Isolation of Cell D or E

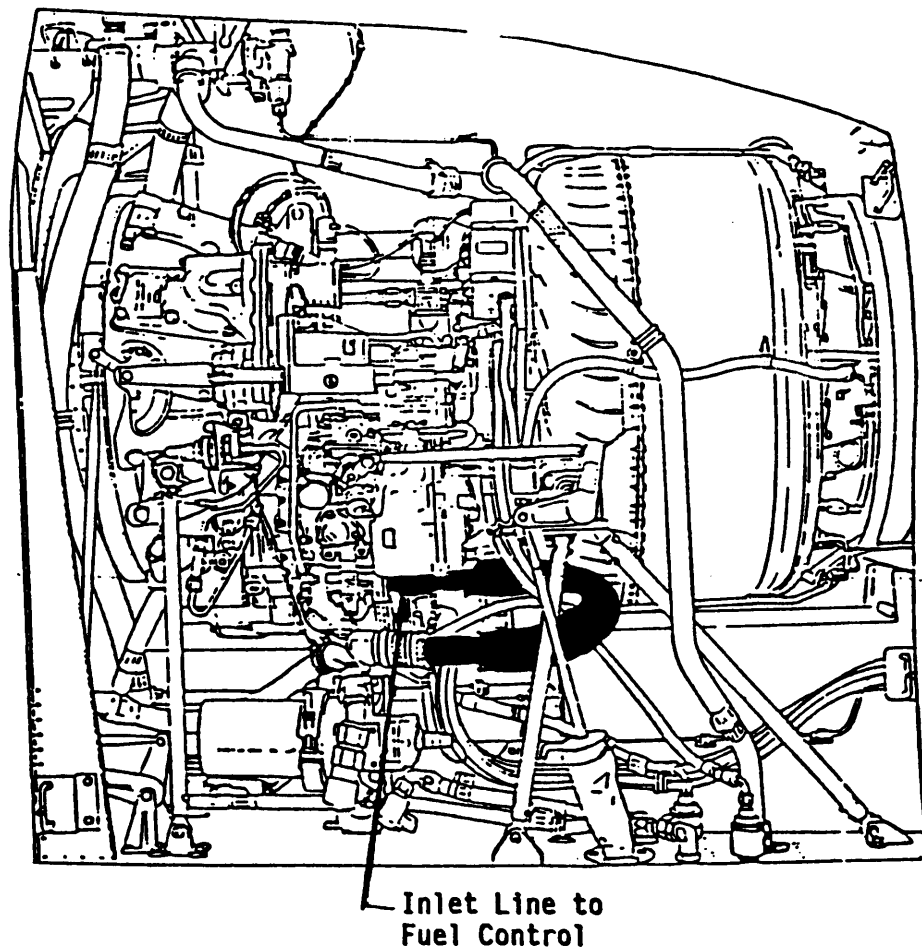

Figure 12-10. Inlet Line to Fuel Control

NOTE

- .Each forward cell has two drain valves, one forward and one aft of internal baffle.
 - .When cover is installed after defueling, use only enough torque to slightly compress seal.
 - d. Each electric boost pump (1) has a drain valve.
 - e. To drain main fuel filter (3, Figure 12-1), use valve in drain line from filter sump. Access is by opening lower left engine cowl. Drain line discharges just forward of aft landing gear cross tube.
2. Locate the damage (i.e., hole or tear) on the cell.

NOTE

- For holes less than 2 inches across, use the 3 inch clamp. For holes greater than 2 inches across but less than 3 inches across, use the 5 inch clamp. Holes larger than 3 X 1 inches in area are nonrepairable; isolate the damaged cell per paragraph 12-8.
3. Use knife to clean up hole up to 2 inches maximum for a 3 inch clamp and a 3 inch maximum for the 5 inch clamp, Figure 12-11.
4. Using Figure 12-11 as a guide, insert the bottom plate of the clamp through the hole and pull up using the cord. Position the plate so the hole is entirely within the gasket area. Slip the top plate over the threaded stud and hand tighten the wing nut.

CAUTION

Excessive mechanical tightening of the wing nut can result in failure of the clamp. The wing nut shall be finger tightened and the maximum torque on the wing nut shall not exceed 10 to 12 inch-pounds.

- 5. Refuel the aircraft.
- 6. Record BDAR action taken. When mission is complete, as soon as practical, repair the equipment/system using standard maintenance procedures.

OPTION 2: Adhesive Patch Repair.

GENERAL INFORMATION: Generally, emergency adhesive repairs can be accomplished within 2 inches of exposed metal of fuel cell fittings and to damage in any other fuel cell area for which a onetime flight capability is required, Figure 12-12.

NOTE

Emergency adhesive repair provides temporary fuel leakage protection only. It does not stop fuel activation of self-sealing construction which will eventually cause cell degradation.

LIMITATIONS: Onetime emergency flight inspection before any second flight.

PERSONNEL/TIME REQUIRED:

- 1 Soldier
- | 3 Hours

MATERIALS/TOOLS REQUIRED:

- Abrasive Cloth, 320 Grit (item 119, App C)
- Cement Repair Kit (item 35, App C)
- Knife and Scissors (items 118, 161, Sec II, App B)
- Ž Repair Fabric Patch (item 91, App C)
- Solvent (items 1, 76, App C)

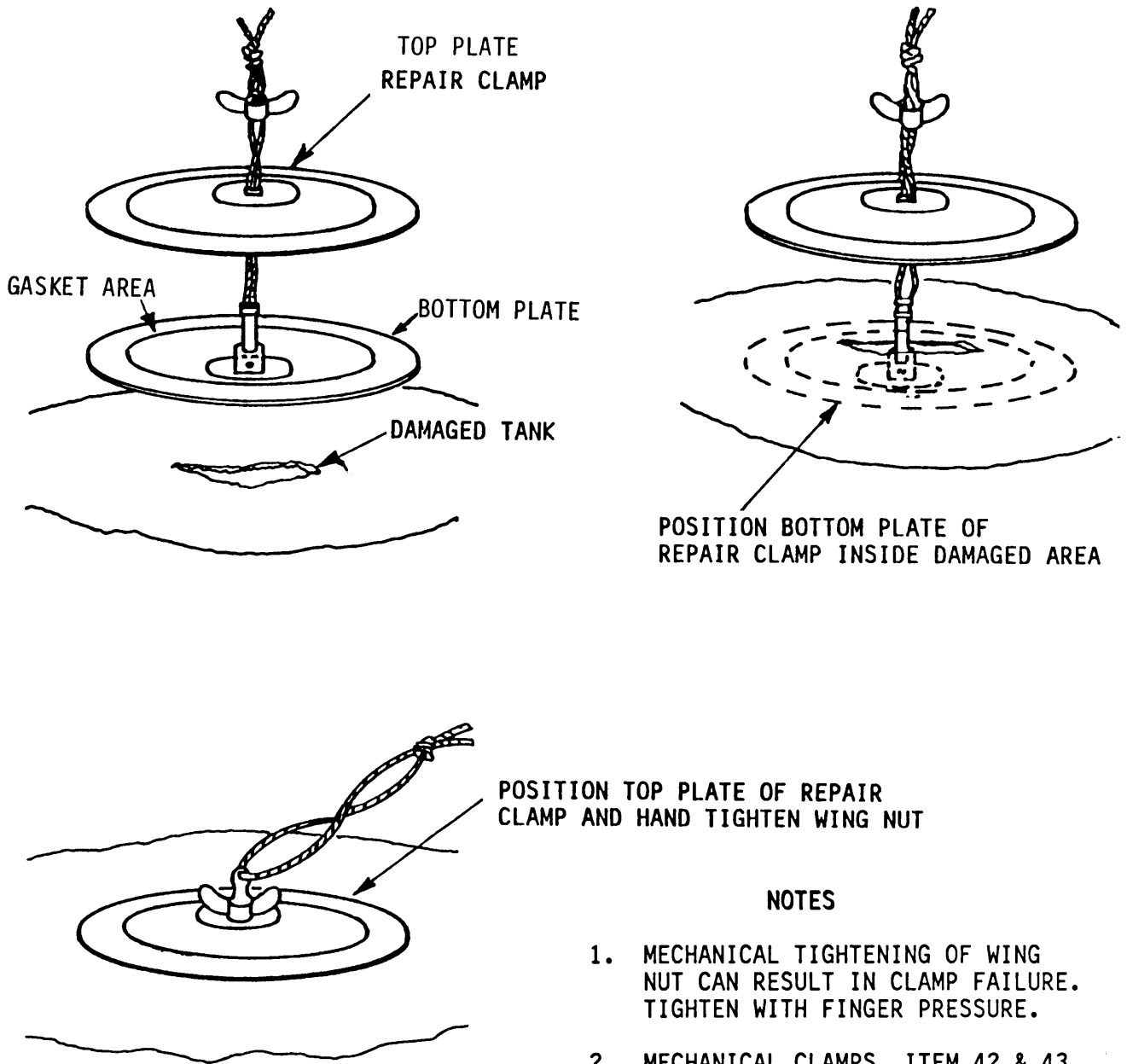

NOTES

1. MECHANICAL TIGHTENING OF WING NUT CAN RESULT IN CLAMP FAILURE. TIGHTEN WITH FINGER PRESSURE.
2. MECHANICAL CLAMPS, ITEM 42 & 43 APPENDIX C.

Figure 12-11. Emergency Mechanical Clamp Repair

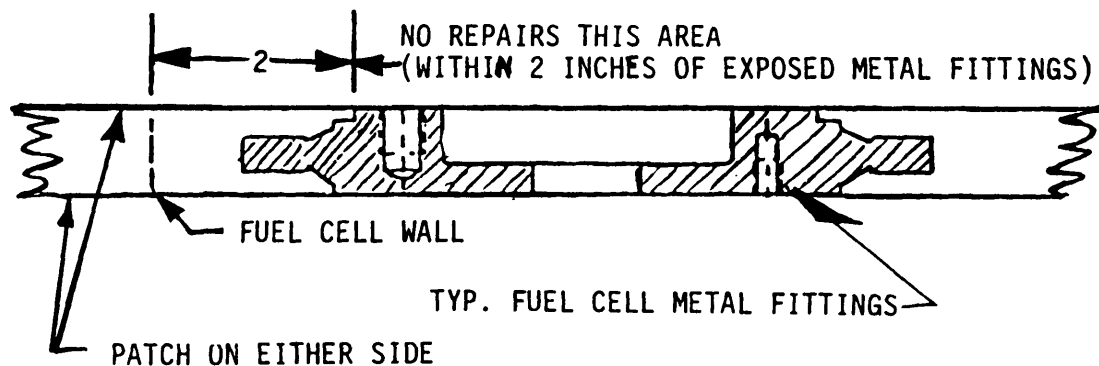

Figure 12-12. Fuel Cell Patch Repair

PROCEDURAL STEPS:

1. Defuel the aircraft. Refer to option 1, step 1.

NOTE

Repairs can be accomplished from either the exterior or interior of the fuel cell, whichever is the fastest way to gain access to damaged area. Patch can be applied either internal or externally.

2. Trim the outer exposed damaged area to provide a reasonably smooth exterior surface. DO NOT ENLARGE HOLE beyond 1 X 3 inches.

3. Abrade and solvent wash the area surrounding the damage using solvent at least 4 inches beyond the damage.

4. Cut a fabric patch to overlap the damaged area by a minimum of 1 inch all the way around. Soak the patch in solvent. (NOTE: No hole is required in the center of the patch.)

5. Prepare the adhesive per instructions on the package of adhesive cement.

6. Apply adhesive to the wound opening for at least 1-1/2 inches around the damaged area or enough to accept the patch cut in step 4 (above).

7. Position the solvent soaked fabric patch on the applied adhesive and smooth it out.

8. Apply additional adhesive if required to seal the patch to the tank and smooth out the surface.

CAUTION

The patch will tend to slip when applying additional adhesive and smoothing. Be sure to recenter the patch.

9. Maintain the patch position for 30 minutes until the adhesive sufficiently sets. Then allow the adhesive to cure 2 hours before refueling.

10. Refuel the aircraft.

11. Record BDAR action taken. When mission is complete, as soon as practical, repair the equipment/system using standard maintenance procedures.

12-10. FUEL FILTER ASSEMBLY, DAMAGED AND LEAKING.

LIMITATIONS: Bypassing of fuel filter assembly can result in contaminated fuel with sediment or foreign particles entering the engine fuel system and causing damage.

PERSONNEL/TIME REQUIRED:

- . 1 Soldier
- 30 Minutes

MATERIALS/TOOLS REQUIRED:

- . Common Hand Tools (App B)

PROCEDURAL STEPS:

1. Open left engine access panel to gain access to external fuel filter.
2. Disconnect hose fitting (1, Figure 12-13) from breakaway fitting (2).
3. Disconnect elbow (3) from filler (4) outlet port.
- 4* Bypass the filter assembly by connecting hose fitting (1) to elbow fitting (3).
5. Test repair by starting engine. Inspect for leaks.
6. Record BDAR action taken. When mission is complete, as soon as practical, repair the equipment/system using standard maintenance procedures.

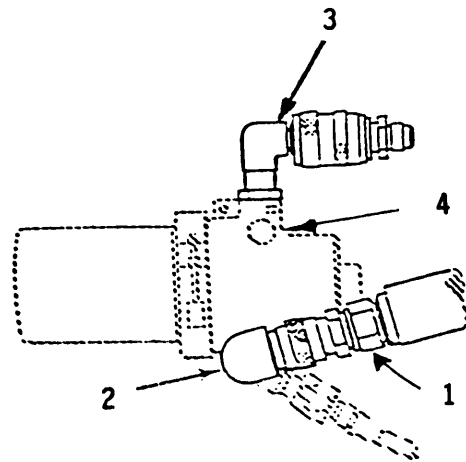

Figure 12-13. Filter Bypass Detail

CHAPTER 13
FLIGHT CONTROLS

**BDAR FIXES SHALL BE USED ONLY IN COMBAT OR FOR TRAINING
AT THE DISCRETION OF THE COMMANDER.
(AUTHORIZED TRAINING FIXES ARE LISTED IN APPENDIX E.)
IN EITHER CASE, DAMAGES SHALL BE REPAIRED BY STANDARD
PROCEDURES AS SOON AS PRACTICABLE.**

Section I. INTRODUCTION

13-1. SCOPE.

a. The purpose of this chapter is to provide BDAR repairs to flight control system which consists of the cyclic controls, collective controls, power controls, elevator controls, and tail rotor controls. See Figures 13-1 thru 13-5.

b. The majority of repairs listed will deal with BDAR on connecting links and bellcranks.

(1) Connecting links are rigid solid rods or tubes. They consist of a middle link with attaching fittings on each end.

(2) Bellcranks, horns, and levers are all typical mechanical parts. They are used to increase/decrease output force and travel distance, and to change direction of input/output force.

13-2. ASSESSMENT PROCEDURES. See Table 13-1.

13-3. REPAIR PROCEDURE INDEX.

	<u>PARA.</u>
Connecting Links Damaged to Center of Link (ends undamaged)	13-5
Link End Fitting, Fabrication of	13-5
Link, Fabrication of Complete.	13-5
Short Connecting Link	13-5
Levers and Bellcranks	
Levers, Fabrication of.	13-7
Bellcrank, Fabrication of	13-9
Elevator Horn Damage Repair	13-11
Control Cables Repair	13-12

Section II. CONNECTING LINKS

13-40 GENERAL.

a. Most of the long connecting links are hollow aluminum tubes with attachment fittings riveted on the ends. Some short links are solid metal. BDAR fixes described in this section are to be used for fixing complete break or separation of links.

b. If connecting link is cut by damage or if it must be cut for repair, refer to Table 13-2 for the correct length of center to center attachment holes.

c. Not all the hardware of nuts, bolts, washers, locknuts, and other hardware used is listed in this chapter. Refer to TM 55-1520-204-25/1 for hardware specifications. Some hardware listed will reference to Appendix C.

d. TM 55-1520-210-23 provides installation and removal instructions for the connecting links.

TM 55-1520-210-BD
FLIGHT CONTROLS

1. Link, P/N 204-001-011-13
2. Link, P/N 204-001-016-13
3. Link, P/N 204-001-012-31
4. Link, P/N 204-001-012-13
5. Link, P/N 200-001-027-5
6. Link, P/N 205-001-014-1
7. Link, P/N 205-001-011-13 (typical)
8. Bell crank P/N 204-001-373-1
9. Link, P/N 204-001-018-27

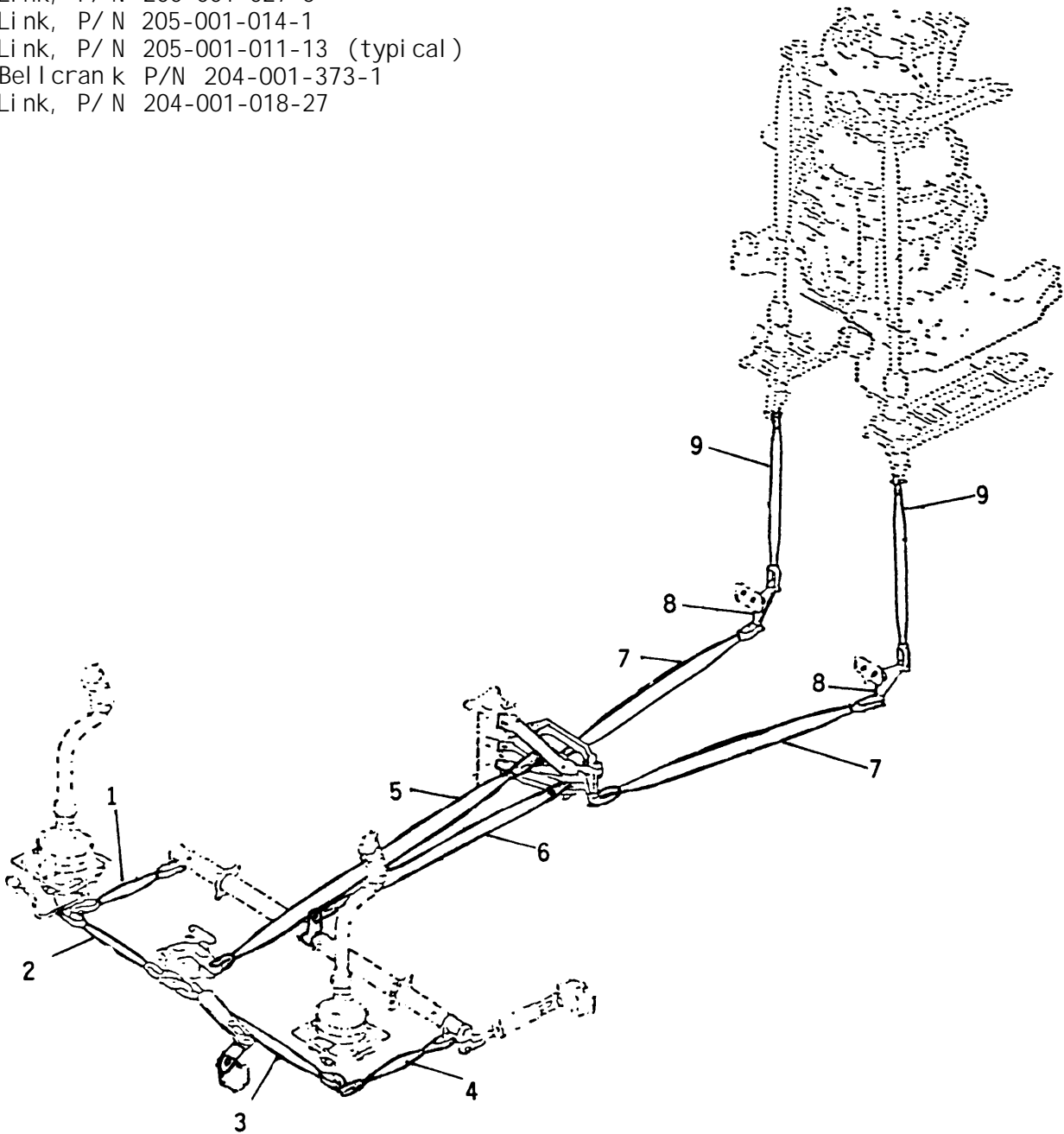

Figure 13-1. Cyclic Control System

1. Link, P/N 203-001-027-23
2. Lever, P/N 204-001-603-1
3. Link, P/N 205-001-011-17
4. Bell crank (see TM-55-1520-210-23P)
5. Link, P/N 205-060-702-1
6. Link, P/N 205-001-013-1
7. Link, P/N 205-060-712-1

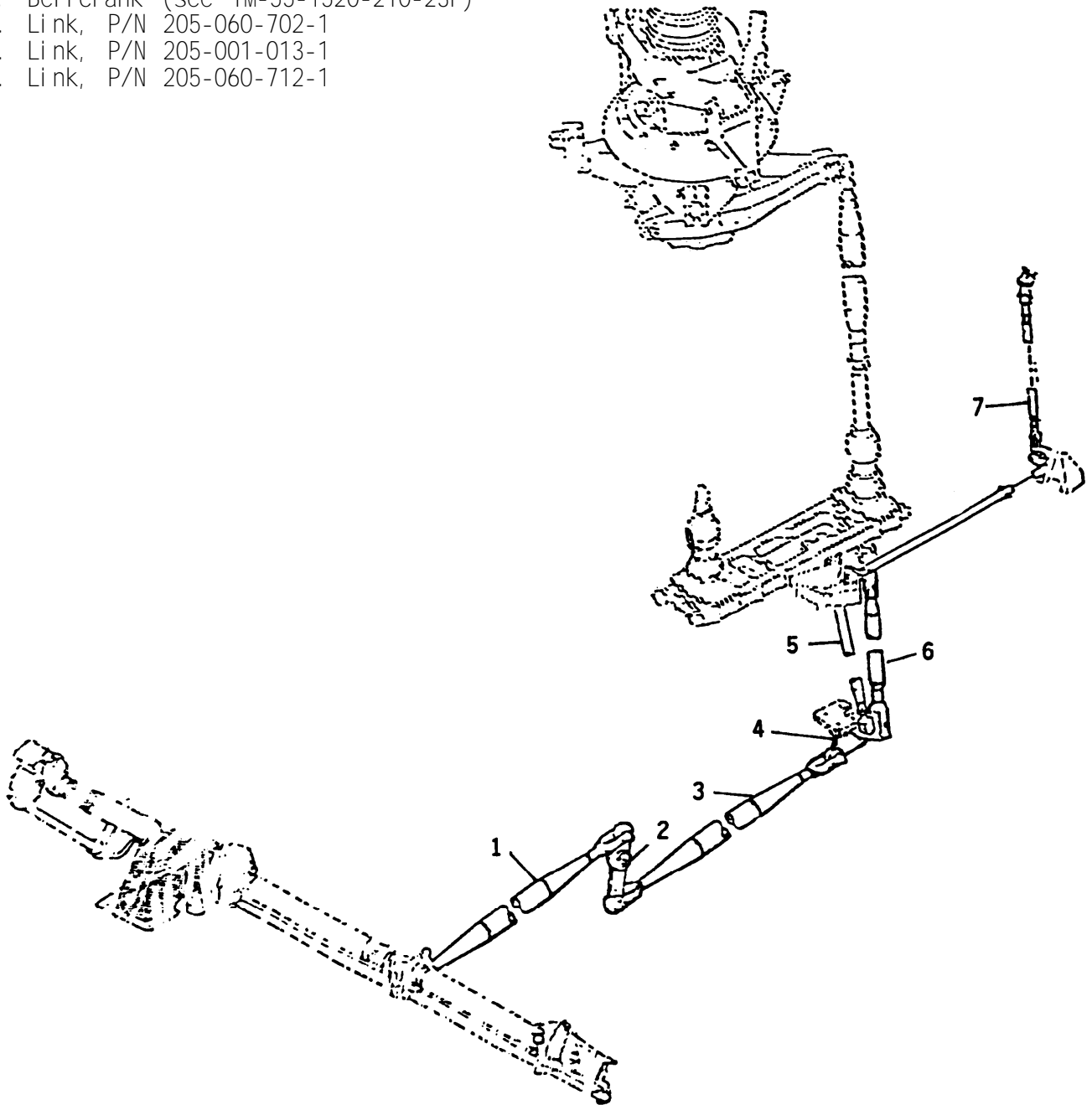

Figure 13-2. Collective Control System

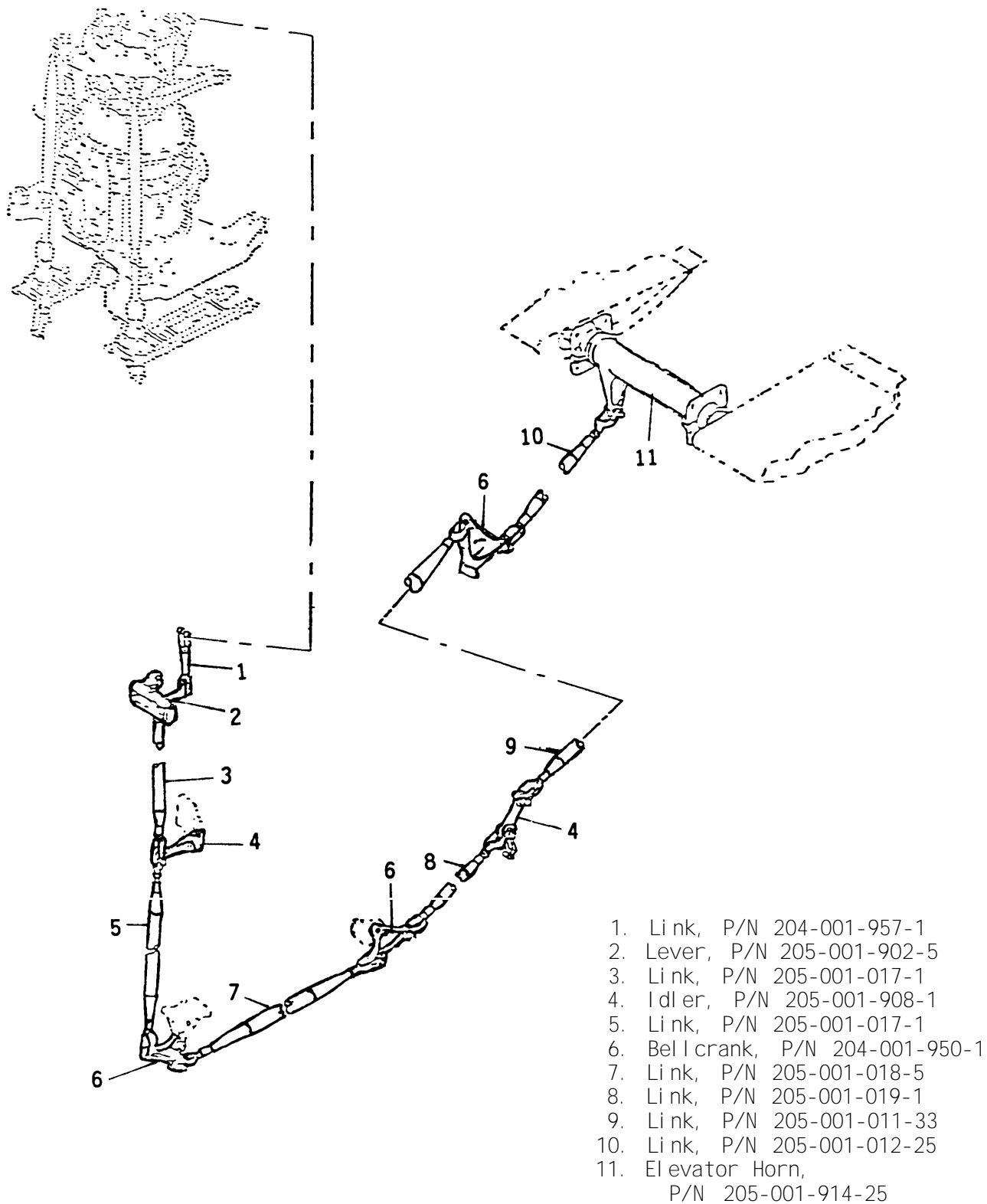

Figure 13-3. Elevator Control System

1. Link, P/N 204-061-716-7
2. Link, P/N 204-001-602-1
3. Link, P/N 204-060-734-9
4. Lever (typical, see TM 55-1520-210-23P)
5. Link, P/N 205-060-729-19
6. Link, P/N 205-060-729-21
7. Bellcrank (typical)
8. Link, P/N 205-060-729-23
9. Link, P/N 205-060-729-25
10. Link, P/N 205-060-734-11
11. Link, P/N 205-060-733-9

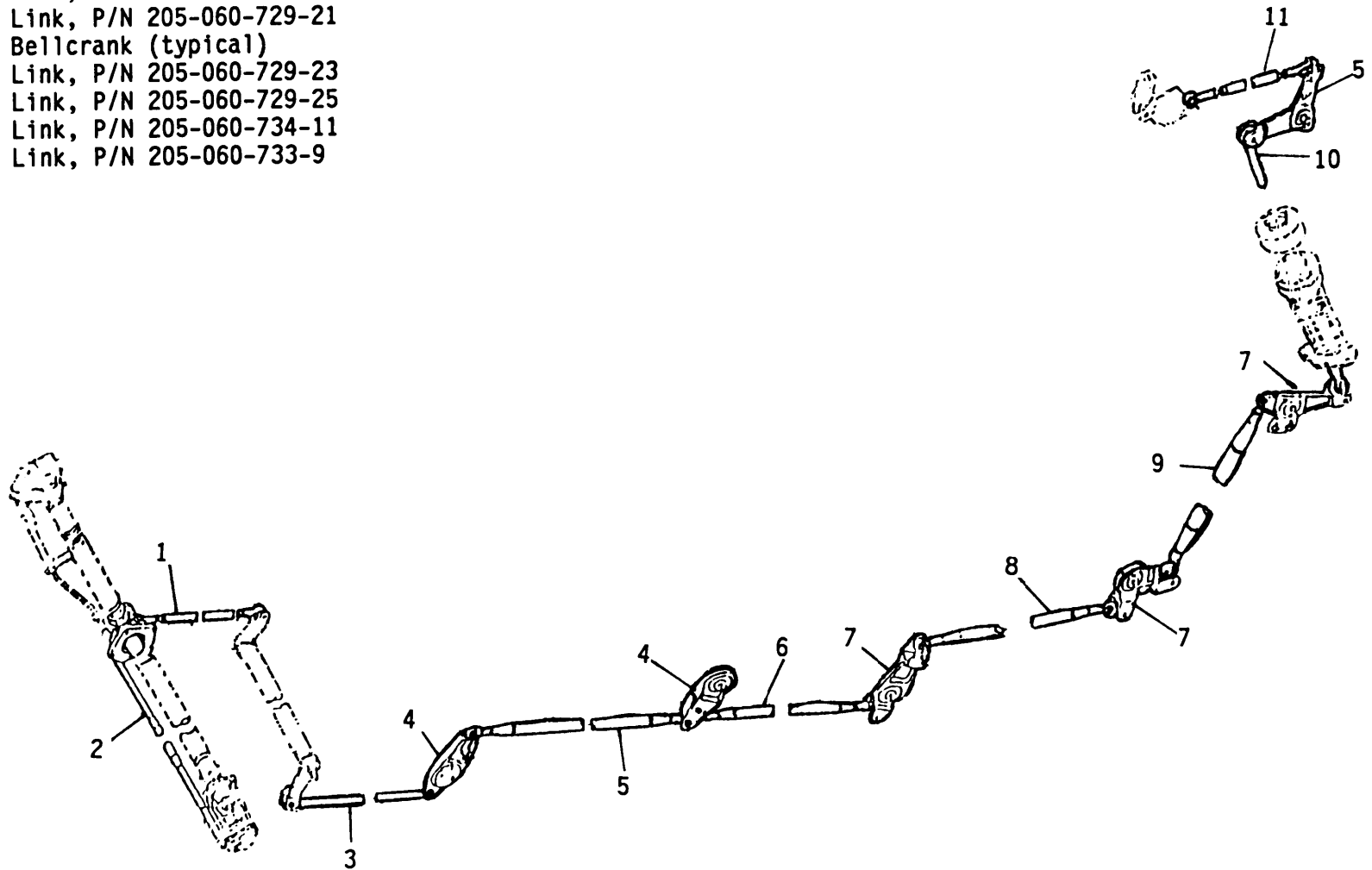

Figure 13-4. Power Control System

TM 55-1520-210-BD
 FLIGHT CONTROLS

1. Link, P/N 204-001-014-7 (typical)
2. Link, P/N 204-001-012-1
3. Link, P/N 205-001-011-9
4. Lever, P/N 205-001-704-1 &
 P/N 204-001-855-1
5. Link, P/N 205-001-011-5
- 60 Link, P/N 205-001-011-1
- 7* Bellcrank (typical, see
 P/N 205-001-728-1 &
 P/N 204-001-832-1
8. Link, P/N 205-001-715-1
 (see Fig 13-9)
- 90 Link, P/N 205-001-012-19
- 100 Control Cable, P/N 205-001-706-9
- 110 Control Chain

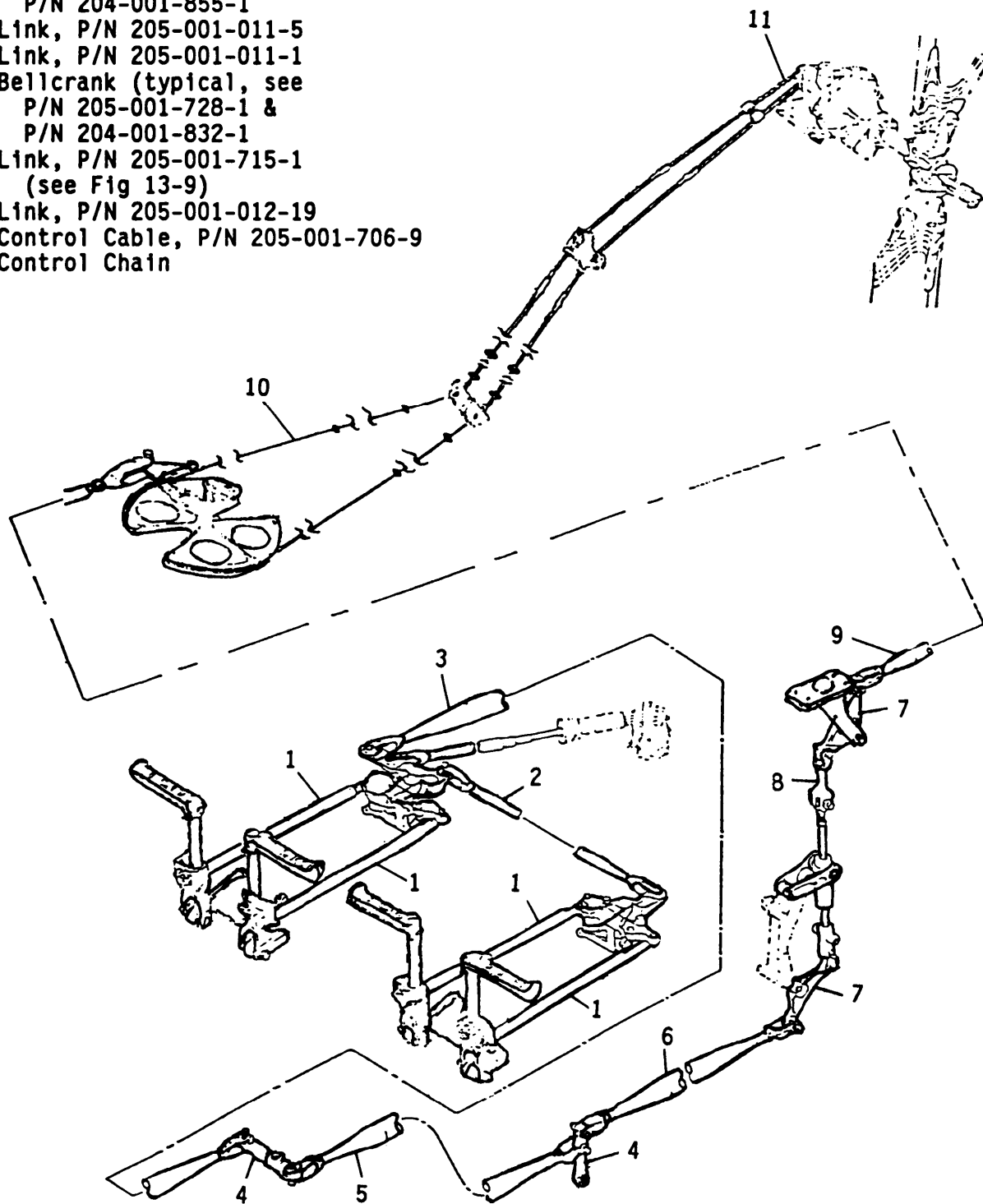

Figure 13-5. Tail Rotor Control System

Table 13-1. Assessment Procedures (Cont)

ITEM/ACTION

FAULT ISOLATION

BDAR REF.

VISUALLY INSPECT

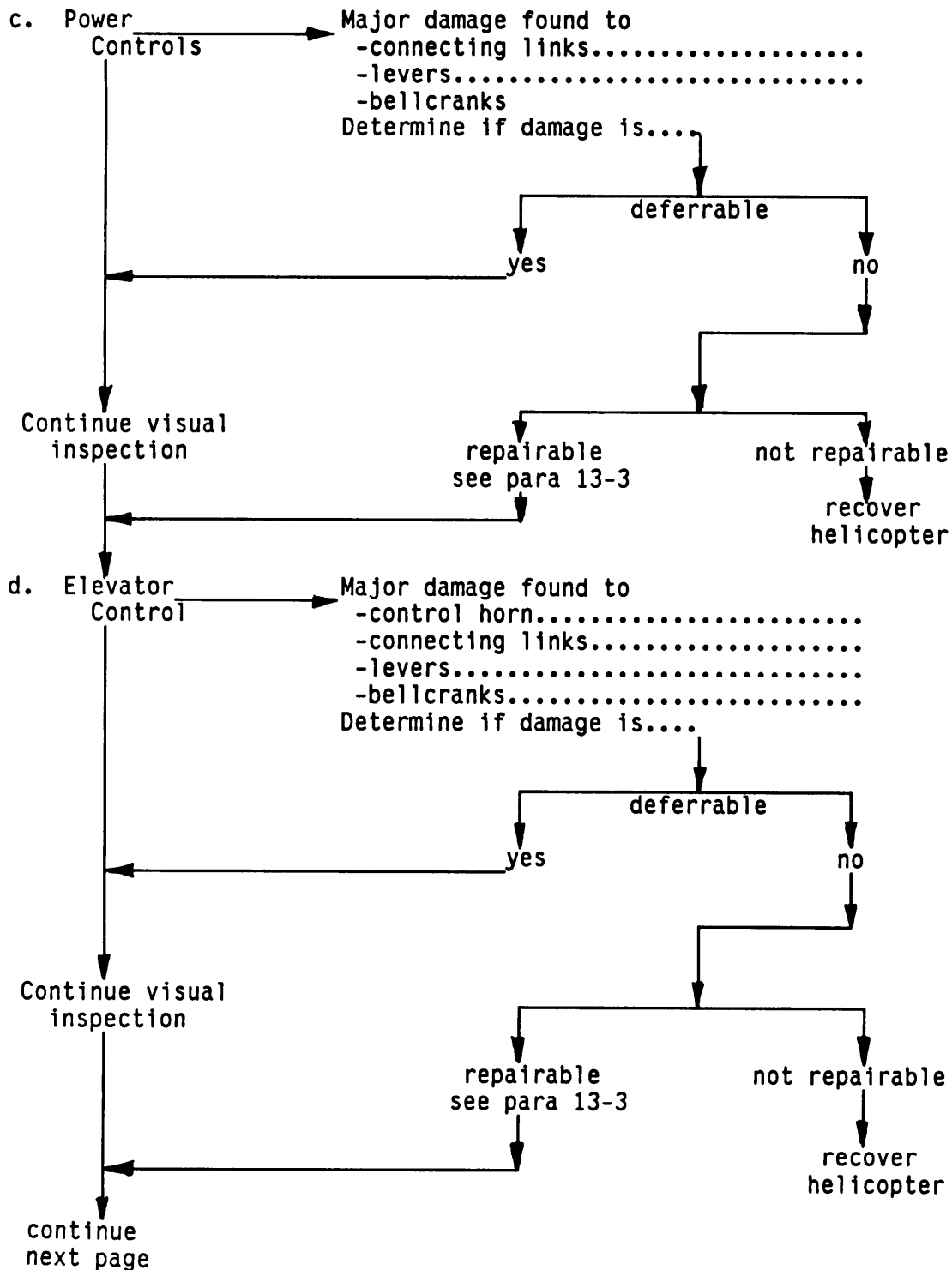

Table 13-1. Assessment Procedures (Cent)

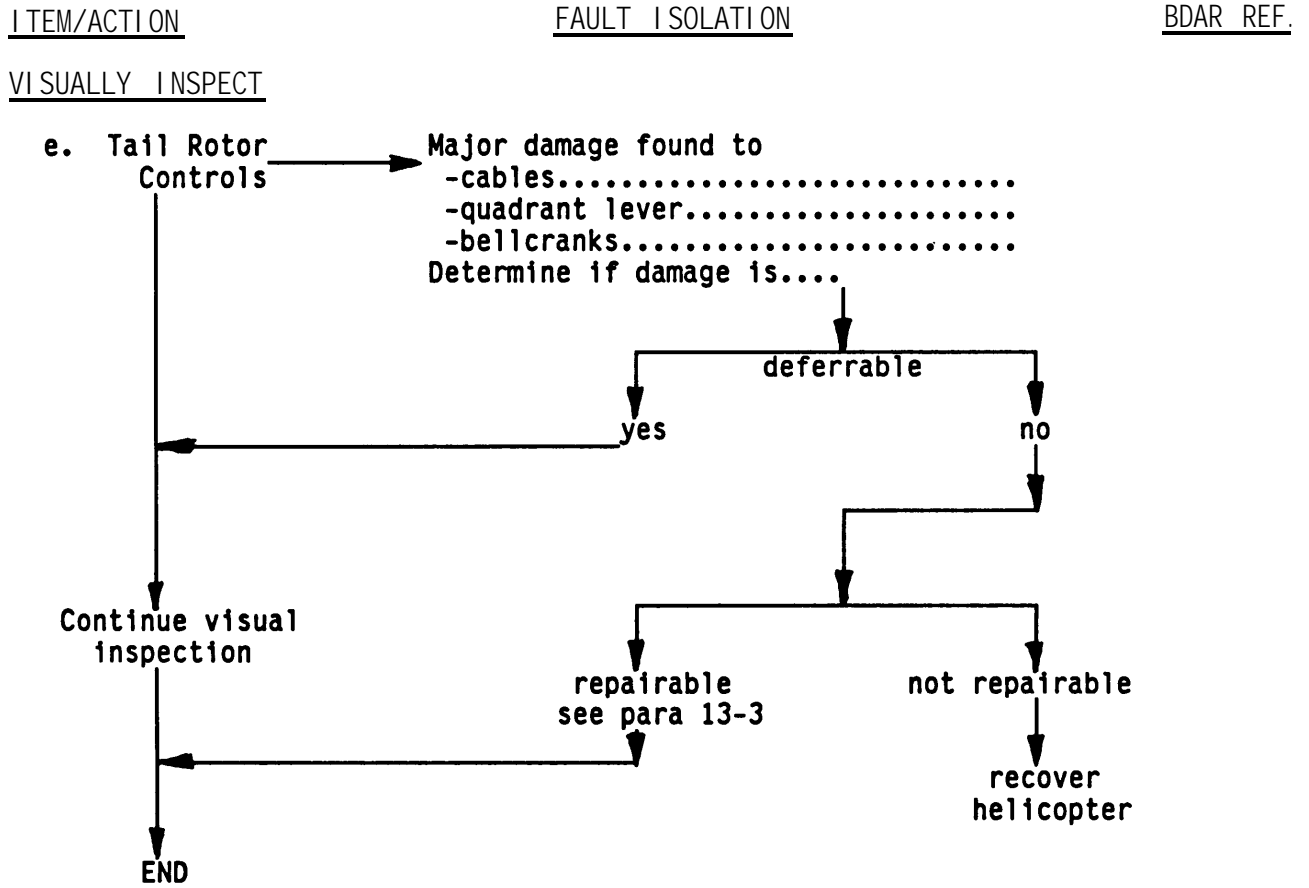

Table 13-2. Connecting Link Dimensions
(Refer to Figures 13-1 thru 13-5)

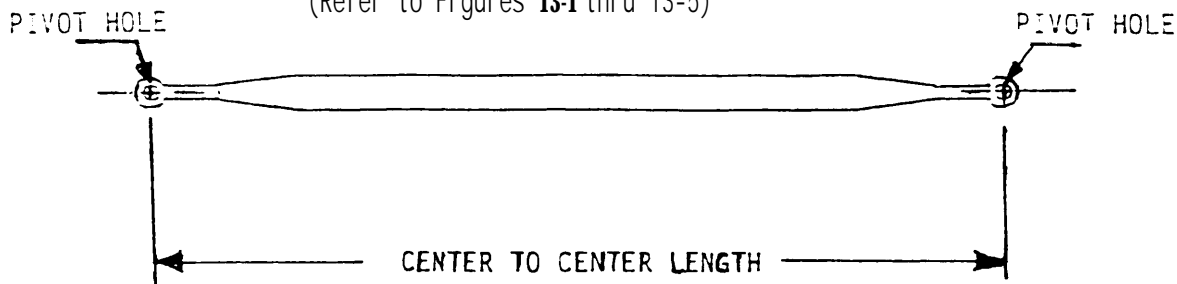

FIGURE	ITEM NO.	PART NO. & NSN	ORIGINAL LINK SIZE (INCHES)		WALL THICKNESS INCHES	NOMINAL C. TO C. LENGTH INCHES	DESIRED TUBE SPLICE O.D. (INCHES)	
			O.D.	I.D.			INSIDE TYPE SPLICE	OUTSIDE TYPE SPLICE
13-2	1	204-001-027-23 3040-00-886-5994	1 3/4	1 41/64	.049	50.34	1 5/8	1 7/8
13-2	3	205-001-011-17 3040-00-995-1333	1 3/4	1 41/64	.049	53.93	1 5/8	1 7/8
13-2	6	205-001-013-1 3040-00-963-0945	7/8	49/64	.049	27.87	3/4	1
13-2	5	205-060-702-1 3040-00-792-1494	3/4	11/16	.028	37.68	5/8	7/8
13-2	7	205-060-712-1 3040-00-967-7679	1/2	27/64	.035	20.47	3/8	5/8
13-1	1	204-001-011-13 3040-00-624-5139	3/4	41/64	.049	15.55	5/8	7/8
13-1	2	204-001-016-13 3040-00-624-5122	3/4	41/64	.049	16.12	5/8	7/8
13-1	3	204-001-012-31 3040-00-624-5146	3/4	41/64	.049	26.67	5/8	7/8
13-1	4	204-001-012-13 3040-00-624-5143	3/4	41/64	.049	15.55	5/8	7/8
13-1	5	204-001-027-5 3040-00-624-5109	1 1/2	1 25/64	.049	56.32	1 3/8	1 5/8
13-1	6	205-001-014-1 3040-00-964-5072	1 3/8	1 17/64	.049	40.70	1 1/4	1 1/2
13-1	7	205-001-011-13 3040-00-964-5068	1 1/8	1 1/64	.049	40.44	1	1 1/4
13-1	9	204-001-018-27 3040-00-775-7739	7/8	49/64	.049	25.55	3/4	1
13-3	1	204-001-957-1 3040-00-731-8093	3/4	43/64	.035	10.21	5/8	7/8
13-3	3	205-001-017-1 3040-00-052-6312	1 1/8	1 1/64	.049	30.05	1	1 1/4
13-3	5	205-011-017-7 3040-00-964-5073	1 1/4	1 9/64	.049	42.95	1 1/8	1 1/2

Table 13-2. Connecting Link Dimensions (Cont)
(Refer to Figures 13-1 thru 13-5)

FIGURE	ITEM NO.	PART NO. & NSN	ORIGINAL LINK SIZE (INCHES)		WALL THICKNESS INCHES	NOMINAL C.TO C. LENGTH INCHES	DESIRED TUBE SPLICE O.D. (INCHES)	
			O.D.	I.D.			INSIDE TYPE SPLICE	OUTSIDE TYPE SPLICE
13-3	7	205-001-018-5 3040-00-246-4554	1 1/2	1 25/64	.049	56.10	1 3/8	1 5/8
13-3	8	205-001-019-1 3040-00-952-7145	1	57/64	.049	31.45	7/8	1 1/8
13-3	9	205-001-011-33 3040-00-051-3648	1 3/4	1 41/64	.049	71.38	1 5/8	1 7/8
13-3	10	205-001-012-25 3040-00-877-2954	1 3/8	1 17/64	.049	40.05	1 1/4	1 1/2
13-5	1	204-001-014-7 3040-00-736-3999	3/4	41/64	.049	22.12	5/8	7/8
13-5	2	204-001-012-1 3040-00-624-5142	1 1/4	1 9/64	.049	44.00	1 1/8	1 3/8
13-5	3	205-001-011-9 3040-00-952-8835	1 1/2	1 25/64	.049	58.03	1 3/8	1 5/8
13-5	5	205-001-011-5 3040-00-964-5066	1 3/4	1 41/64	.049	53.93	1 5/8	1 7/8
13-5	6	205-001-011-1 3040-00-964-5064	1 3/4	1 41/64	.049	62.89	1 5/8	1 7/8
13-5	9	205-001-012-19 3040-00-051-3647	1 3/4	1 41/64	.049	61.32	1 5/8	1 7/8
13-4	2	204-001-602-1 3040-00-859-2742	3/4	43/64	.035	43.00	5/8	7/8
13-4	1	204-061-716-7 3040-00-939-7531	1/2	27/64	.035	21.41	3/8	5/8
13-4	3	205-060-734-9 3040-00-952-9754	1/2	27/64	.035	13.95	3/8	5/8
13-4	5	205-060-729-19 3040-00-952-7152	5/8	35/64	.035	37.90	1/2	3/4
13-4	6	205-060-729-21 3040-00-952-7153	5/8	35/64	.035	23.91	1/2	3/4
13-4	8	205-060-729-23 3040-00-952-7149	5/8	35/64	.035	24.01	1/2	3/4
13-4	9	205-060-729-25 3040-00-952-7150	5/8	35/64	.035	33.57	1/2	3/4
13-4	10	205-060-734-11 3040-00-952-9755	1/2	27/64	.035	21.31	3/8	5/8
13-4	11	205-060-733-9 3040-00-952-7147	3/8	19/64	.035	11.17	1/4	1/2

TM 55-1520-210-BD
FLIGHT CONTROLS

13-5. CONNECTING LINKS, DAMAGED IN CENTER (both attaching ends acceptable).

OPTION 1: Splice Repair. See Figure 13-6.

LIMITATIONS: One flight and inspection of area before and after flight.

PERSONNEL/TIME REQUIRED:

- 1 Soldier
- 2 Hours

MATERIALS/TOOLS REQUIRED:

- Extrusion Angle (items 47-60, App C)
- Tube Stock
- NAS-1304 Bolt (item 19, 21, 23, App C)
- Rivets (items 94-114, App C)

PROCEDURAL STEPS:

1. Remove damaged connecting link from helicopter.
2. Trim damaged area. Do not cut unless necessary.

WARNING

Do not use soft aluminum rivets to join splices. Use steel rivets, tempered aluminum rivets, monel rivets, or steel bolts.

3. Select a metal splice inner, outer, or angle, whichever is more suitable. See Figure 13-6.
4. Splice should overlap damaged area a minimum of 3 X diameter on each side. See Figure 13-6.
5. Drill at least two bolt/rivet holes through tube, and splice on each side of damaged area. See Table 13-3 for bolt/hole sizes.
6. Holes should be in 90° cross pattern. See Figure 13-6 for spacing.

a. Inside type splice start measurement at edge of damaged area working outward.

b. Outside type splice or angular splice start measurement at end of splice and work inward.

NOTE

Angular splice angles should be held in place with water hose clamps, safety wire, etc. before drilling.

7. Make sure that original center to center length is maintained, Table 13-2.
8. Reinstall link after repairs accomplished, and check for binding or interference by manually moving appropriate controls through several cycles.
9. Record BDAR action taken. When mission is complete, as soon as practical, repair the equipment/system using standard maintenance procedures.

Table 13-3. Bolt/Drill Sizes for Splice Repairs

LINK NOM OD	MINIMUM BOLT SIZE		MAXIMUM BOLT SIZE	
	FOR BOLT	DRILL HOLE	FOR BOLT	DRILL HOLE
5/8	No. 6	9/64	NO. 8	No. 19
3/4	8	No. 19	10	9
7/8	10	9	1/4	LTR F
1	10	9	1/4	LTR F
1/8	10	9	1/4	LTR F
1-1/4	1/4	LTR F	5/16	LTR O
1-3/8	1/4	LTR F	5/16	LTR O
1-1/2	5/16	LTR O	3/8	LTR V

OPTION 2: Fabrication of Connecting Link End. Link damaged at one end, Figure 13-7.

LIMITATIONS: One flight limitation.

PERSONNEL/TIME REQUIRED:

- 1 Soldier
- 2 Hours

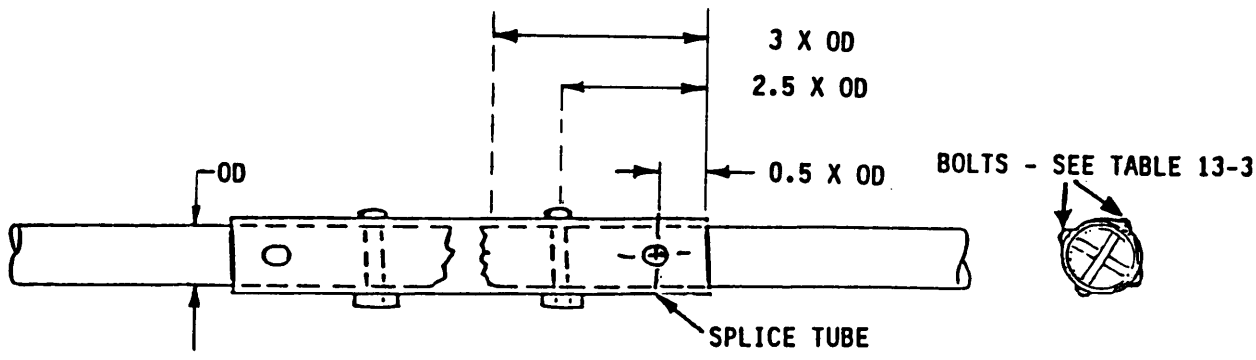

A. SLEEVE OVER LINK OD

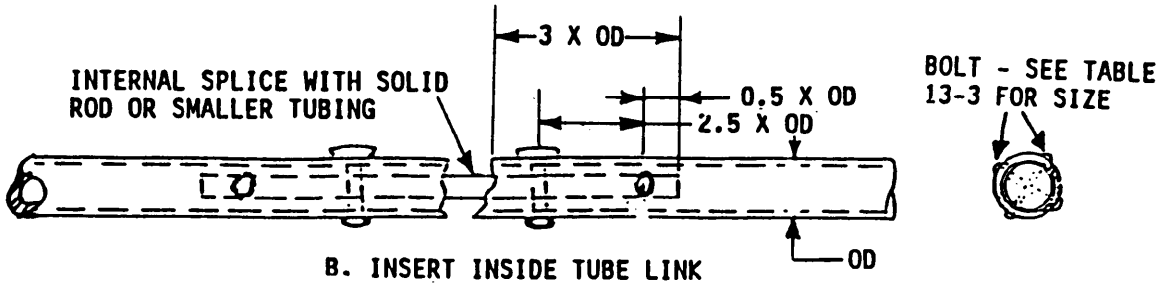

B. INSERT INSIDE TUBE LINK

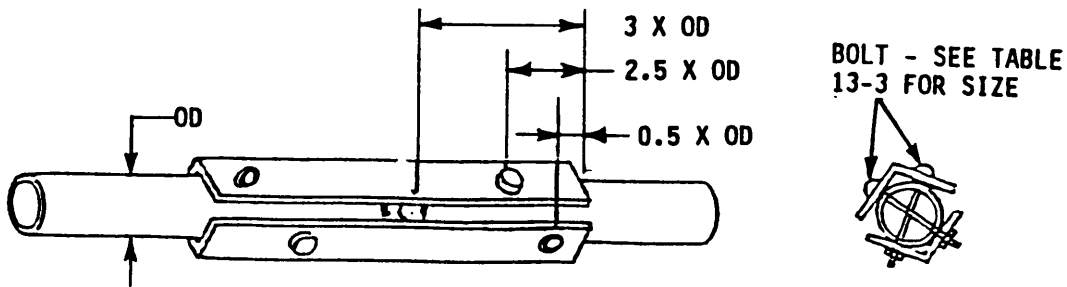

C. STRUCTURAL ANGLES (SPLINT) OVER SOLID OR TUBE LINK

Figure 13-6. Control Connecting Link Splices

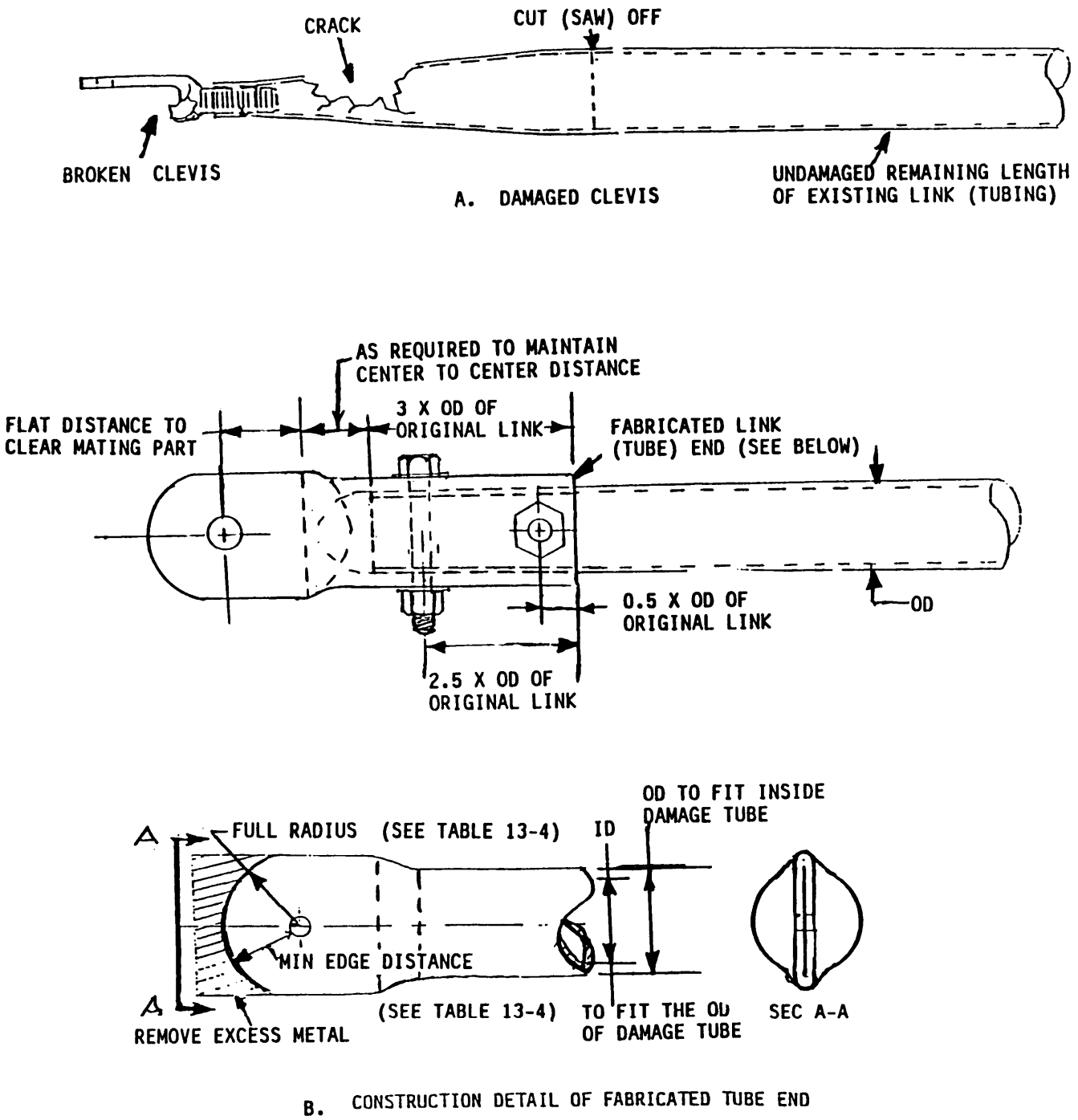
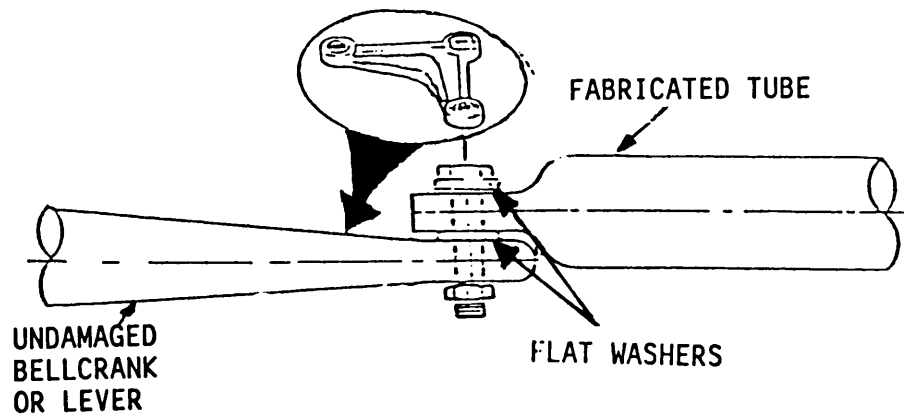
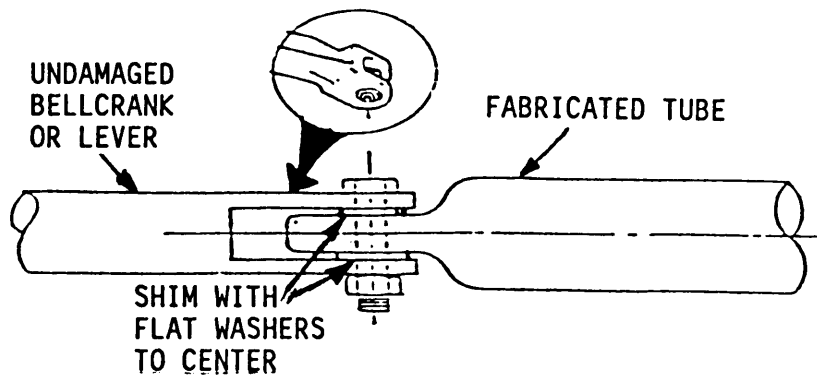

Figure 13-7. Fabrication of Link End (Sheet 1 of 2)



E. INSTALLATION OF FABRICATED CONNECTING LINK ON A BELLCRANK OR LEVER WITH A BEARING TYPE END



F. INSTALLATION OF FABRICATED CONNECTING LINK END ON TO BELLCRANK OR LEVER WITH A CLEVIS TYPE END

Figure 13-7. Fabrication of Link End (Sheet 2 of 2)

MATERIALS/TOOLS REQUIRED: Tube Stock (same or larger diameter as original tube, 0.035 in. min. wall thickness).

PROCEDURAL STEPS:

1. Remove damaged connecting link from helicopter.
2. Measure accurately center to center length of damaged connecting link, Table 13-2.
3. Trim/remove damaged area from connecting link.
4. Select a length of new bulk tubing or cannibalized tubing for the replacement end. Length of replacement tubing must be a longer than damaged length to allow for fabrication process, Figure 13-7.
5. Form one end of replacement link flat as shown in Figure 13-7, sheet 1 of 2.
6. Slip open end of replacement link into or over original link.
7. Mark center to center length taken in step 2. Punch mark **pivot hole**.
8. Refer to Table 13-4 and Figure 13-7, sheet 1 of 2. Select correct radius from table and lay on tube end as shown in Figure 13-7.
9. Drill proper size pivot hole to match original link hole diameter.
10. Trim and file off excess metal from connecting link end.
11. Slip fabricated end into or over trimmed end of original end. Overlap a minimum of 3 X OD of original link OD.
12. Drill at least two bolt holes through link and splice. See Table 13-3 for bolt and hole sizes.
13. Holes should be in 90° cross pattern. See Figure 13-7 for spacing of bolt holes.

14. Make sure original center to center length, measured in step 2, is maintained.

WARNING

Use self-locking nuts, double nuts, or cotter pins to retain all flight control pivot bolts.

15. Install repaired link in helicopter. Use flat washers to shim out excess play, but leave approximately 0.010 inch clearance to prevent binding.

NOTE

Flat washers should be large enough to completely cover pivot bearing.

16. Record BDAR action taken. When mission is complete, as soon as practical, repair connecting link with an actual replacement connecting link.

Table 13-4. Fabricated Link End Dimensions

REPAIR TUBE SIZE	RADIUS ±1/32	MINIMUM EDGE DISTANCE
1/2	0.279	0.217
5/8	0.353	0.274
3/4	0.426	0.332
7/8	0.500	0.391
1	0.575	0.450
1-1/8	0.632	0.507
1-1/4	0.706	0.565
1-3/8	0.780	0.623
1-1/2	0.869	0.682
1-3/4	1.05	0.798

OPTION 3: Fabrication of Control Link from Tube.

LIMITATIONS: One flight limitation.

PERSONNEL/TIME REQUIRED:

- 1 Soldier
- 3 Hours

MATERIALS/TOOLS REQUIRED:

- Drill & Bits (item 67, 69, Sec II, App B)
- Common Hand Tools (App B)
- Tube Stock (same or larger dia as original tube, 0.035 in. min. wall thickness, 0.049 preferred)

PROCEDURAL STEPS:

1. Remove damaged connecting link from helicopter.
2. Identify part number of link from location in Figures 13-1 thru 13-5. (P/N may be marked on tube by manufacturer.)
3. Refer to Tables 13-2 and 13-3. Select new bulk tubing or cannibalized tubing of original diameter or larger. Length of replacement link must be longer than original to allow for fabrication process. Refer to Figure 13-8.
4. Mark center to center length taken from Table 13-2.
5. Squeeze ends of replacement link flat as shown in Figure 13-8.
6. Measure accurately and remark center to center length.
7. Punch mark each pivot hole.
8. Refer to Table 13-4. Select correct radius from table and lay on link ends as shown in figure.
9. Drill proper size pivot hole to match original link end.
10. Trim and file off excess metal from link ends.

WARNING

Use self-locking nuts, double nuts, or cotter pins to retain all flight control pivot bolts.

11. Install fabricated connecting link in aircraft. Use flat washers to shim out excess play, but leave approximately 0.010 inch end clearance to prevent binds.

NOTE

Flat washers should be large enough to completely cover pivot bearing.

12. Record BDAR action taken. When mission is complete, as soon as practical, repair the equipment/system using standard maintenance procedures.

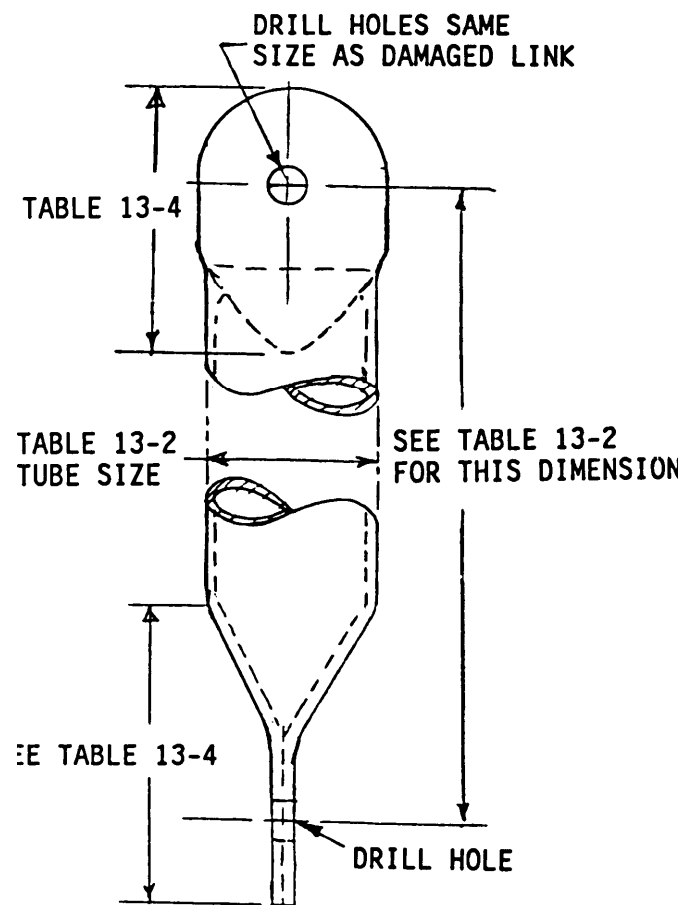

Figure 13-8. Fabrication of Links from Tube

OPTION 4: Fabrication of Short Flight Control Connecting Links Using Bar Stock.

NOTE

This repair option generally should not be used for control tubes or links in excess of 24 inches long unless angle stock or other means are incorporated to prevent bowing.

LIMITATIONS: None.

PERSONNEL/TIME REQUIRED:

- 1 Soldier
- 3 Hours

MATERIALS/TOOLS REQUIRED:

- Common Hand Tools (App B)
- Bolts & Washers (items 11-29, 168, App C)
- Drill & Bits (item 67, 69, Sec II, App B)
- Flat Bar Stock Aluminum 2024T, 7075T, or Steel Bar Stock
- Nuts (item 82-86, App C)

PROCEDURAL STEPS:

1. Remove damaged linkage from helicopter.
2. Refer to Figure 13-9 and select most suitable repair for fabrication of damaged part.

NOTE

Variations and adaptations of these techniques may be utilized to repair several types of parts in addition to those shown.

30 Cut bar stock to match length of damaged linkage. Saw, file, or grind end of bar to form radius shape.

40 If clevis link is fabricated from two bars as shown in Figure 13-9, detail C, drill holes for cross bolts as needed. Assemble cross bolts, washers, and bars to create fabricated link.

5. Mark and drill proper size holes for linkage end pivot bolts. Drilled hole for pivot bolt should be AF.

CAUTION

Overtightening of pivot bolts will cause binding of controls. Use self-locking type nuts, double nutted, or cotter pinned to prevent nuts from working loose.

6. Install link into helicopter flight controls. Tighten pivot bolt nut leaving approximately 0.015 inch bolt axial end play.

7. Cycle controls through several strokes and check for binding or interference.

8. Record BDAR action taken. When mission is complete, as soon as practical, repair the equipment/system using standard maintenance procedures.

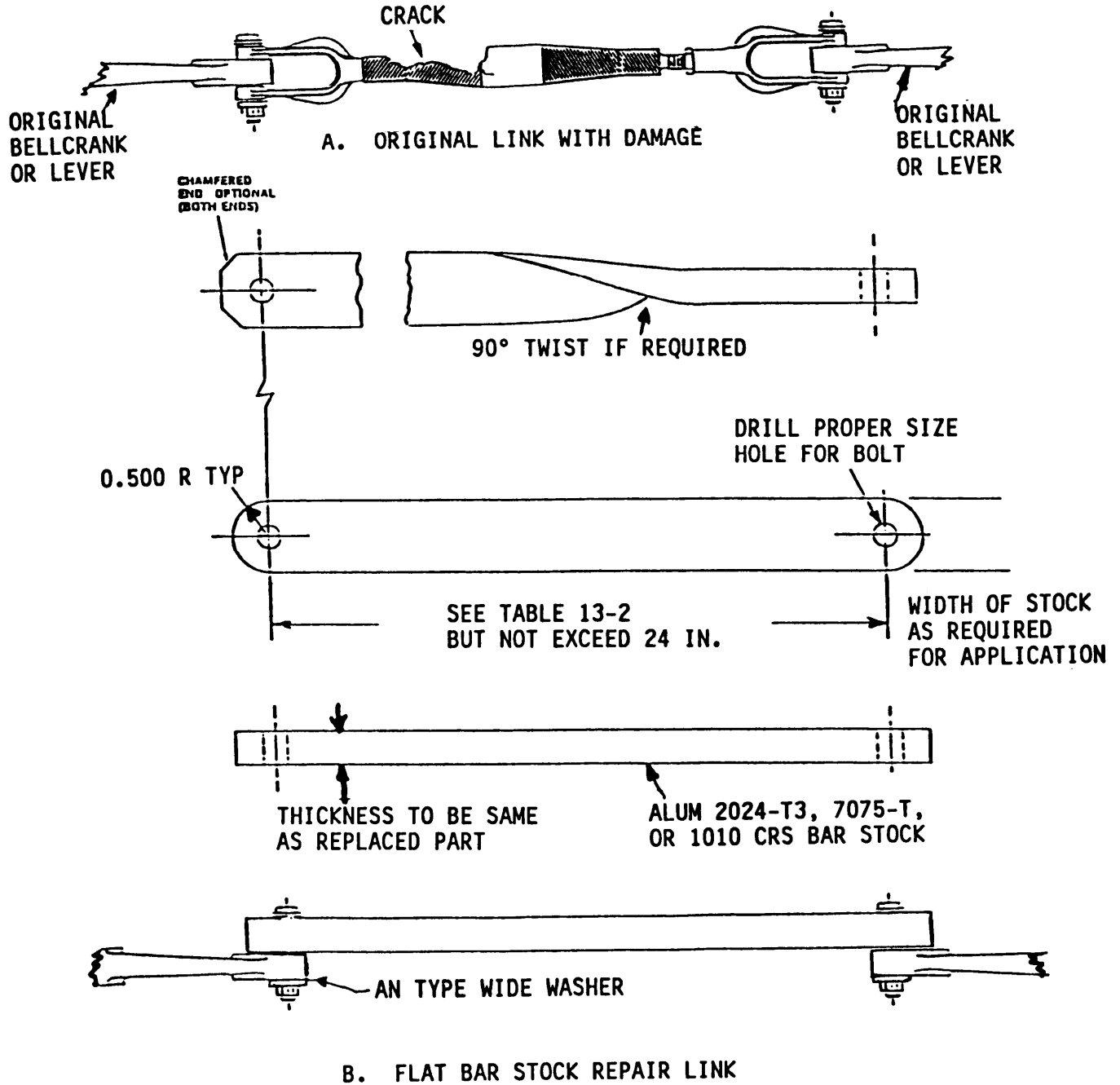
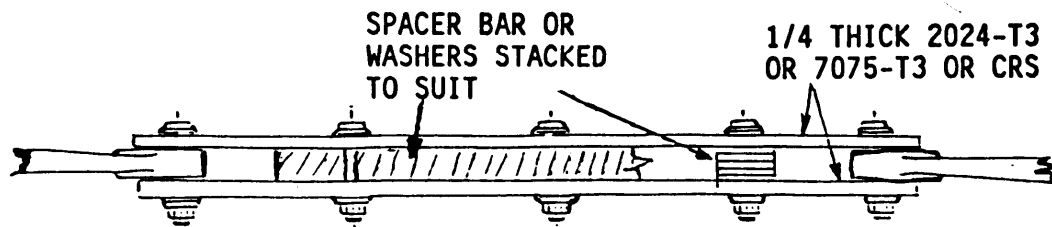
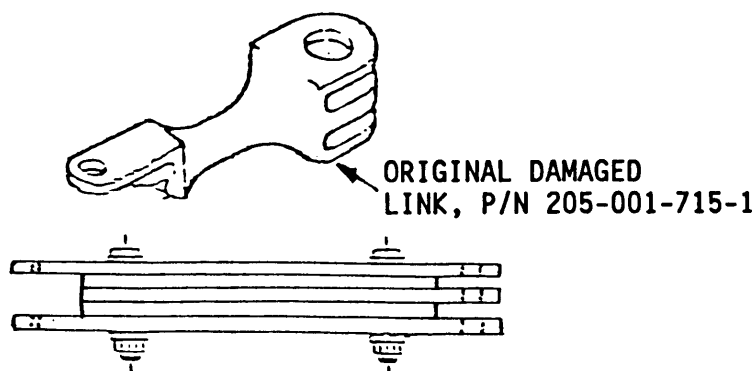

Figure 13-9. Fabrication of Connecting Link (Sheet 1 of 3)



C. FABRICATING LINK WITH CLEVIS ENDS



D. FABRICATION OF TAIL ROTOR (POWER CYLINDER) CONNECTING LINK, P/N 205-001-715-1

Figure 13-9. Fabrication of Connecting Link (Sheet 2 of 3)

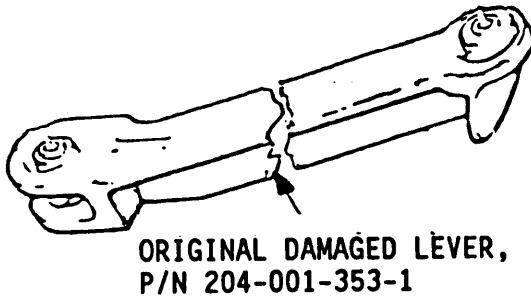

LEVER P/N	"A" DIMENSION	"B"
204-001-353-1	2.155	9.750
204-001-354-1	1.000	9.750

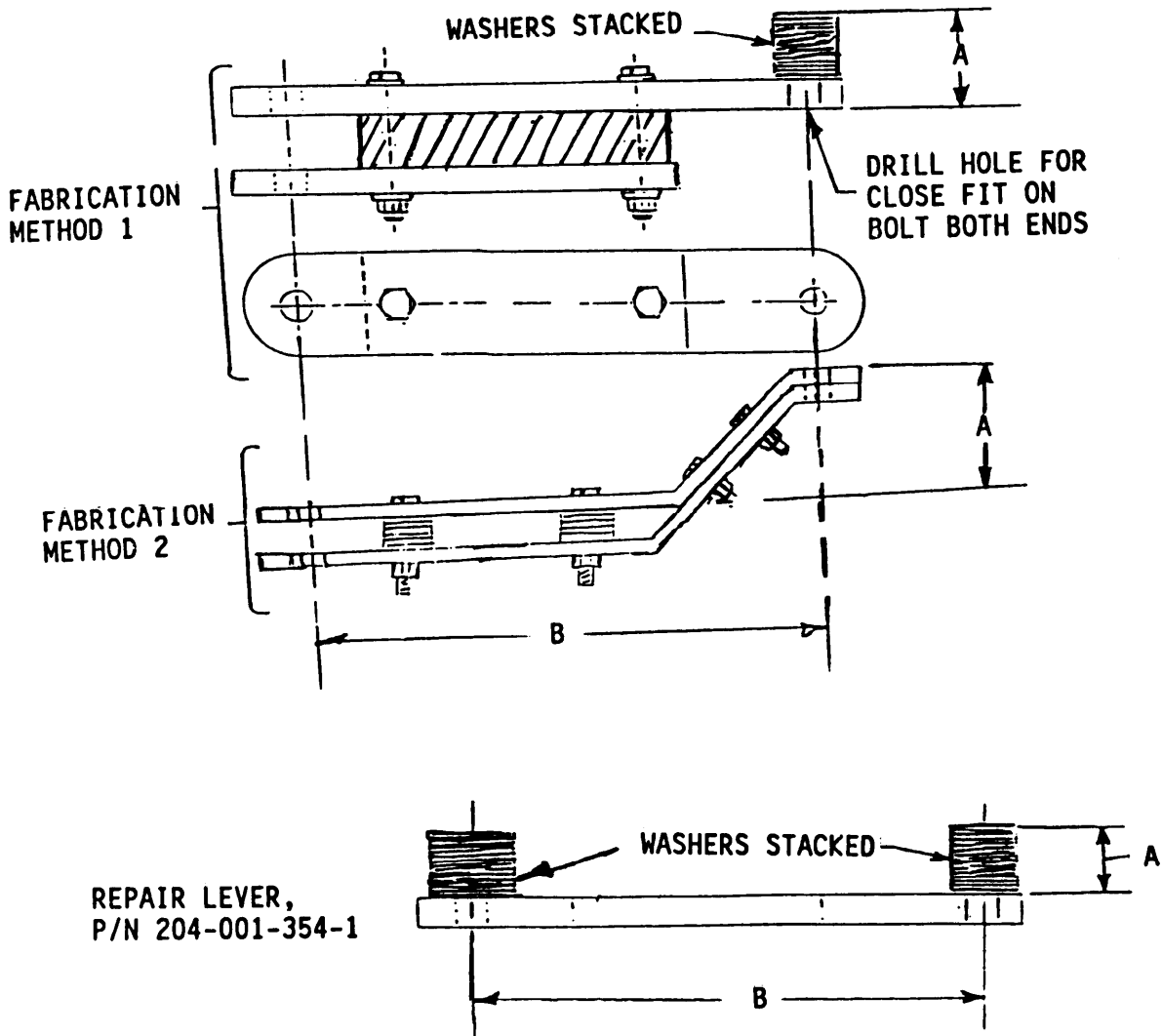

Figure 13-9. Fabrication of Connecting Link (Sheet 3 of 3)

Section III. LEVER ASSEMBLIES

13-6. **GENERAL.** A lever can be fabricated by using the actual damaged lever or another identical lever as a template. A lever from another UH-1H/V helicopter may be used if damaged part is shattered.

13-7. **FABRICATION OF LEVER ASSEMBLY.**

OPTION 5: Fabricate Flight Control Lever.

LIMITATIONS: None.

PERSONNEL/TIME REQUIRED:

- 1 Soldier
- 3 Hours

MATERIALS/TOOLS REQUIRED:

- Common Hand Tools (APP B)
- Drill & Bits (item 67, 69, Sec II, App B)
- 1/2 in. thick (or as needed) X 2 in. wide Aluminum 2024T, 7057T, or Steel Bar Stock

PROCEDURAL STEPS:

1. Remove damaged lever and use as a template to punch mark pivot hole centers, Figure 13-10.
2. Saw off excess stock and round corners.
3. Install lever using flat washers to shim out side play as needed.
4. Record BDAR action taken. When mission is complete, as soon as practical, repair the equipment/system using standard maintenance procedures.

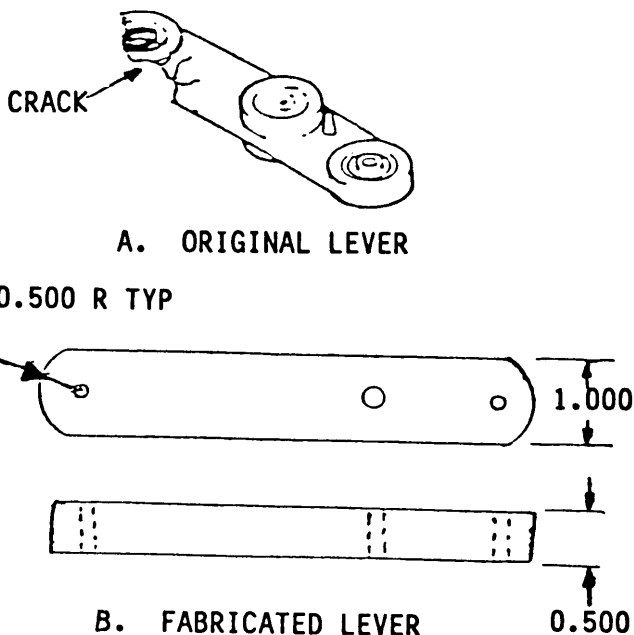

Figure 13-10. Fabrication of Lever from Flat Bar Stock

Section IV. BELLCRANKS

13-8. GENERAL. A bellcrank assembly can be fabricated by using the actual bearing as a template if it is still intact. An identical bellcrank from another UH-1H/V helicopter may be temporarily used as a template if damaged part is not intact.

13-9. FABRICATION OF BELLCRANKS AND LEVERS.

LIMITATIONS: None.

PERSONNEL/TIME REQUIRED:

- 1 Soldier
- 4 Hours

MATERIALS/TOOLS REQUIRED:

- Common Hand Tools (App B)
- Cutting Torch (if steel plate is used)
- Drill & Bits (item 67, 69, Sec II, App B)
- Flat Washers (Items 168-176, App C)
- 3/8 or 1/2 in. Aluminum or Steel Plate Stock

PROCEDURAL STEPS:

1. Remove damaged bellcrank or lever from helicopter.
2. Refer to Figure 13-11A and B. Use old bellcrank or lever as a template. Mark outline and center punch bearing hole locations, or drill holes using bearing holes as guide.

3. Saw or flame cut plate along outline marks. File or grind edges smooth. Round off corners.

4. Refer to Figure 13-11C. Drill same size pivot holes as per original part.

5. Refer to Figure 13-11D. Install fabricated bellcrank or lever into flight control system. Use flat washers as needed to shim out side to side play.

CAUTION

Overtightening of pivot bolts will cause binding of controls. Use self-locking type nuts, double nutted, or cotter pinned to prevent nuts from working loose.

6. Cycle flight controls to check for interference or binds.

7. Record BDAR action taken. When mission is complete, as soon as practical, repair the equipment/system using standard maintenance procedures.

Section V. ELEVATOR

13-10. GENERAL. The elevator is connected and operated by input from the swashplate through a series of control tubes, levers, and bellcranks, Figure 13-3. Any damage to the flight control tubes, levers, and bellcranks which renders the elevator inoperable and which cannot be fixed, will require that the elevator be disconnected completely and locked out to keep in from flapping and affecting flight. This is the only BDAR fix allowed for elevator if it is malfunctioning.

13-110 **ELEVATOR, INOPERABLE.**

LIMITATIONS: Inspect after every flight for no elevator rotation. Do not exceed 40 knots airspeed.

NOTE

This option to be used only if elevator system cannot be made operative.

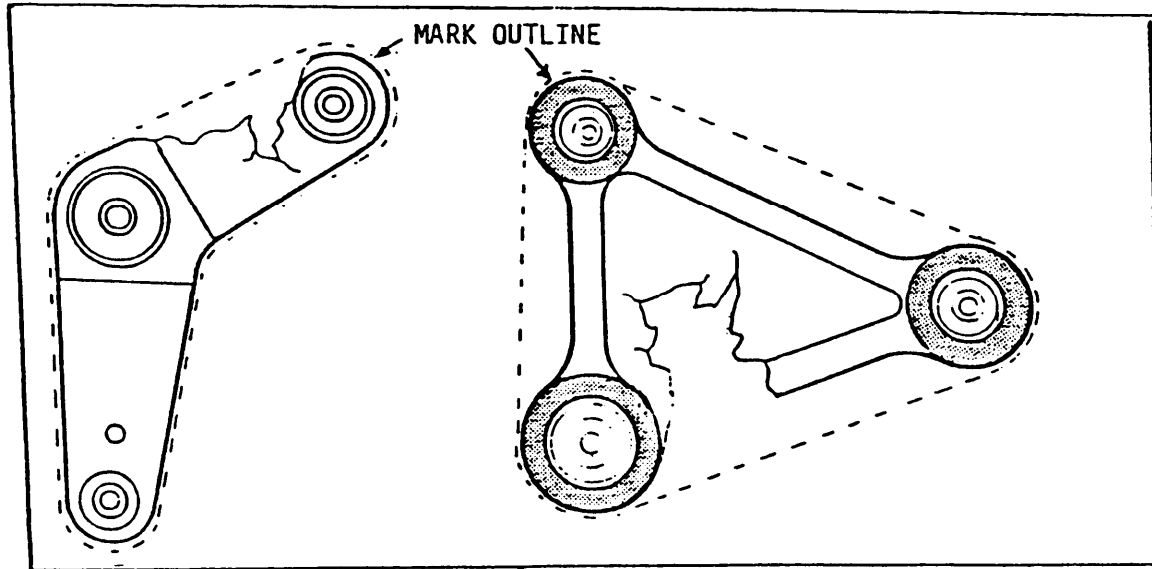

3/8 or 1/2 INCH FLAT PLATE STOCK BLANK

A. LAYOUT PLATE STOCK

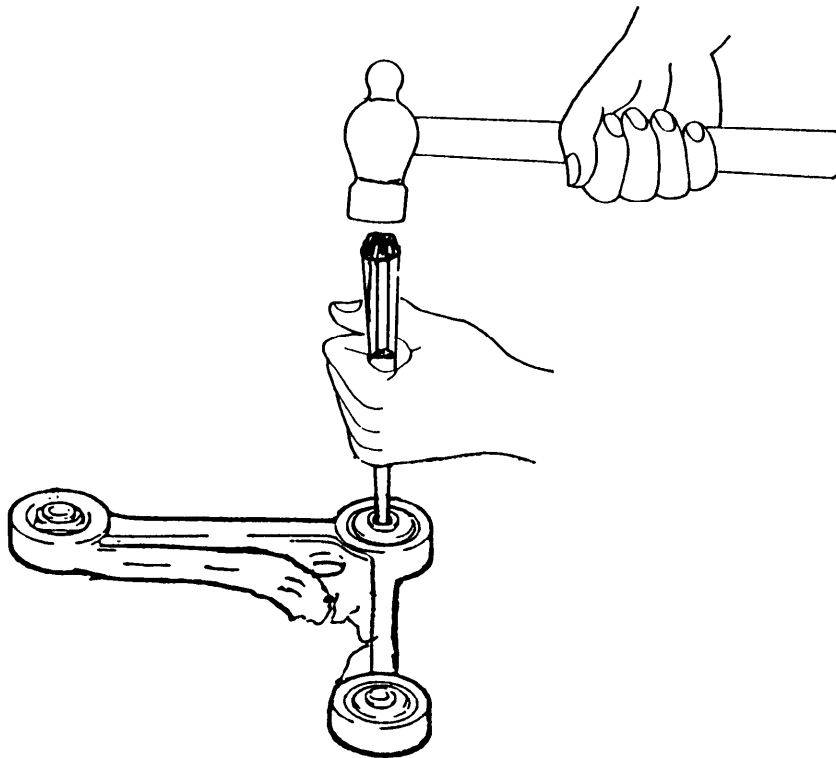

B. PUNCH MARKING PIVOT HOLE CENTERS

Figure 13-11. Fabrication of Bellcranks and Levers (Sheet 1 of 2)

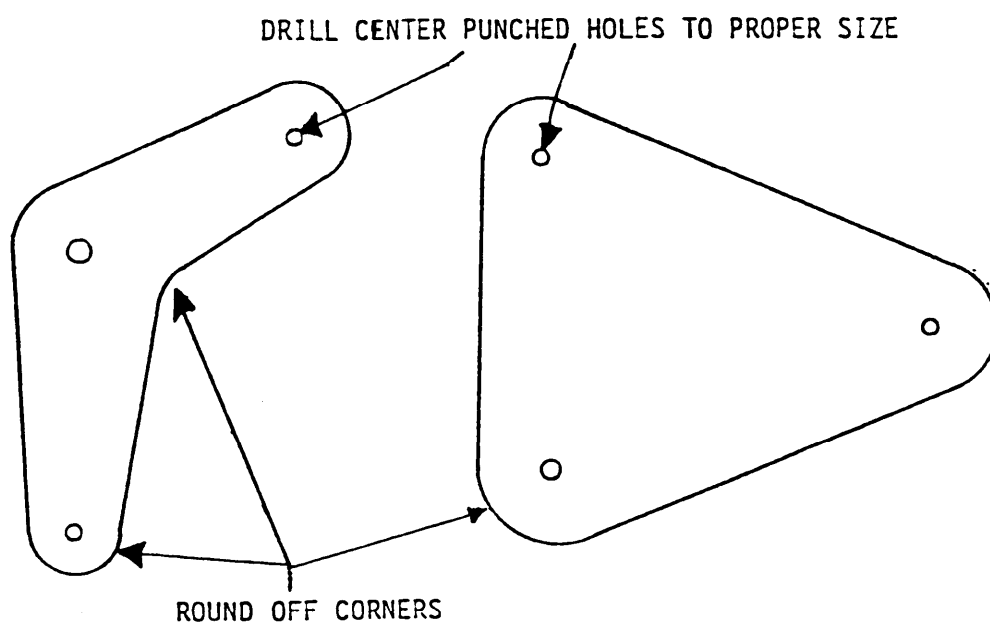

C. FINISHED FABRICATION

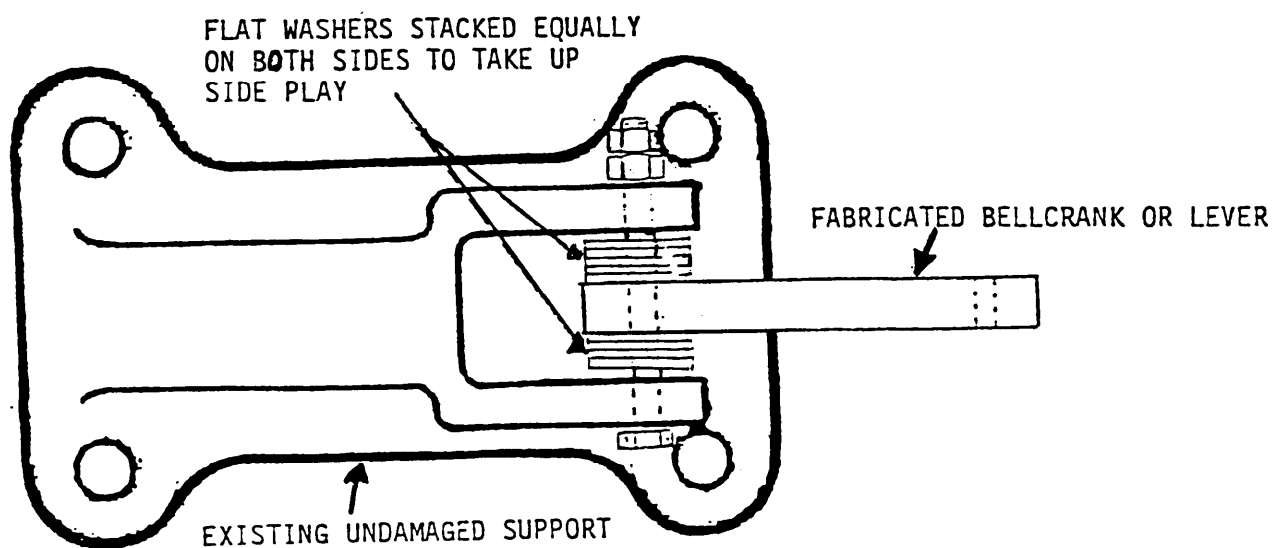

D. FABRICATED BELLCRANK OR LEVER INSTALLATION

Figure 13-11. Fabrication of Bellcranks and Levers (Sheet 2 of 2)

PERSONNEL/TIME REQUIRED:

- 1 Soldier
- 3 Hours

MATERIALS/TOOLS REQUIRED:

- Common Hand Tools (App B)
- 2-Rubber Strips 3/4 in. wide X 6 in. long (item 116, App C)

PROCEDURAL STEPS:

1. Remove at least one control link tube in the elevator control system, preferably all those with damage, Figure 13-3.
2. Ensure that fore and aft movement of cyclic stick and resulting movement of swashplate is not restricted in any way.
3. Remove middle tail boom access cover plate to gain access to elevator horn area.
4. Refer to Figure 13-12. Remove four bolts holding left and right upper support assembly caps.
5. Remove support assembly caps and spacer washers.
6. Cut two pieces of rubber or leather approximately 3/4 X 6 inches. Any material approximately 1/16 to 1/8 inch thick can be used such as rubber hose or shoe leather strips.
7. Clean all lubricants from elevator horn grooves and support assembly caps.
8. Lay rubber or leather strips in horn grooves and install caps. Do not install spacer washers.

NOTE

Rubber or leather strips act as friction brake pads to prevent elevator rotation.

9. Install four bolts removed from each support assembly cap with cyclic control stick set neutral. Set elevator trialing edge to top (neutral rig) rivet 'P.' Tighten the four bolts sufficiently to prevent rotation of elevators.
10. Install tail boom access cover plate.
11. Record BDAR action taken. When mission is complete, as soon as practical, repair the equipment/system using standard maintenance procedures.

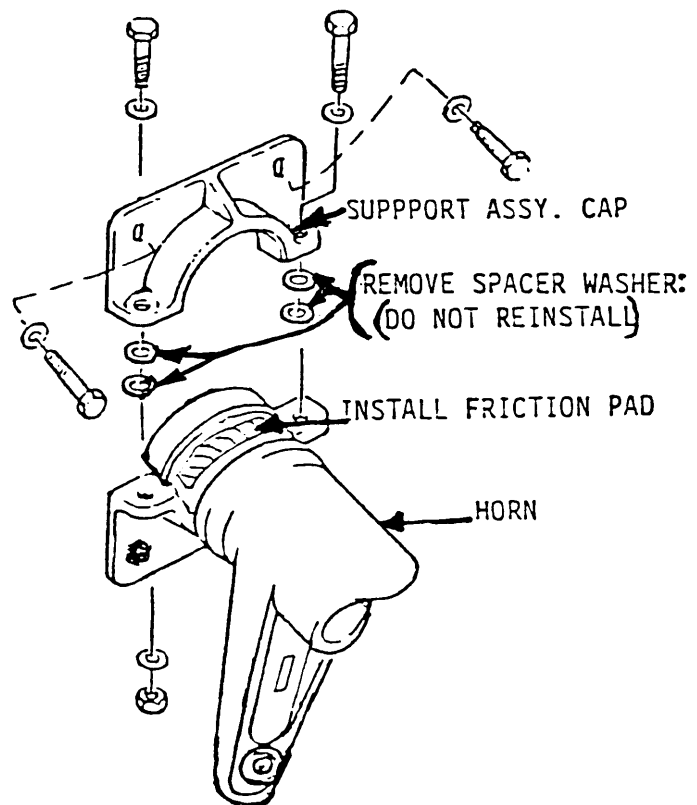

Figure 13-12. Elevator Lock Out

Section VI. CONTROL CABLES

13-12. GENERAL.

a. The UH-1 helicopter has a tail rotor control cable, 1/8 Inch in diameter, which connects a control quadrant (pulley wheel) mounted in front of the tail boom to the other end; a chain/sprocket wheel. This sprocket wheel is attached to and drives the tail rotor pitch control. This cable is part of the mechanical link in the yaw controls of helicopter. It ties the yaw foot pedal controls to the tail rotor pitch control.

b. Damage to the cables can be from minor damage such as a few strands of cable broken to complete separation of cable. Any damage which will prevent free movement of the tail rotor pitch controls must be repaired. The following BDAR repairs are for a complete separated cable.

13-13. CONTROL CABLE, DAMAGED
(SPLICE REPAIR).

LIMITATIONS: None.

PERSONNEL/TIME REQUIRED:

- 1 Soldier
- 2 Hours

MATERIALS/TOOLS REQUIRED:

- Common Hand Tools (App B)
- Stranded Steel Control Cable
- Nicopress Sleeves or Cable Clamps
- Nicopress Crimping Tool

PROCEDURAL STEPS:

1. Remove broken cable preferable at speed rig points. Refer to Figure 13-13A.

WARNING

In all cases, it is preferable to replace the flight control cable rather than repair. Repairs should be made as a last resort for one time flight only. Take care in positioning the joints and clamps. Avoid interference between clamps, structure, and fairleads or pulleys through the required range of movement.

2. Trim the frayed portion of cable back to a point where the cable diameter can be maintained consistently. Select an area where steps in splice (Figure 13-13C&D) will not travel past holes in structure or other structure that would restrict cable travel.

3. Install rig pins at supporting cranks at both ends of cables.

4. Relax opposing cables by adjusting turn buckle five full turns.

5. Cut a piece of the same or larger size cable long enough to overlap both ends of damaged cable. The cable should also be long enough to provide space for two nicopress sleeves or two cable clamps at each splice as shown in Figure 13-13B.

6. Slide two nicopress sleeves or two cable clamps over one end of damaged cable and stock cable. Place end sleeves or clamps 1/4 to 1/2 inch from end of cable as shown in Figure 13-13.

7. Use an Installation tool (P/N 51-P-850) for nicopress sleeves or a wrench for clamps and nuts. Crimp sleeves or tighten clamp nuts.

TM 55-1520-210-BD
FLIGHT CONTROLS

8. Slide two nicopress sleeves or cable clamps onto damaged cable and stock cable at second splice. Match cable slack to undamaged opposing cable. While maintaining this cable slack, crimp sleeves or tighten clamps using an installation tool or wrench.
9. Insert lockwire through eyelet in speed rig, wrap lockwire around pin then back through eyelet. Twist wire to proper length and secure around locking collar at base of speed rig, cut wire to proper length, twist and fold into speed rig cavity, Figure 13-13.

10. Adjust cables to specified tensions.

11. Remove rig pins.

120 Operate control systems through several cycles and check to ensure there are no binds or chaffing in the splice area. Ensure that nicopress sleeves or cable clamps clear adjacent structure.

13* Record BDAR action taken. When mission is complete, as soon as practical, repair the equipment/system using standard maintenance procedures.

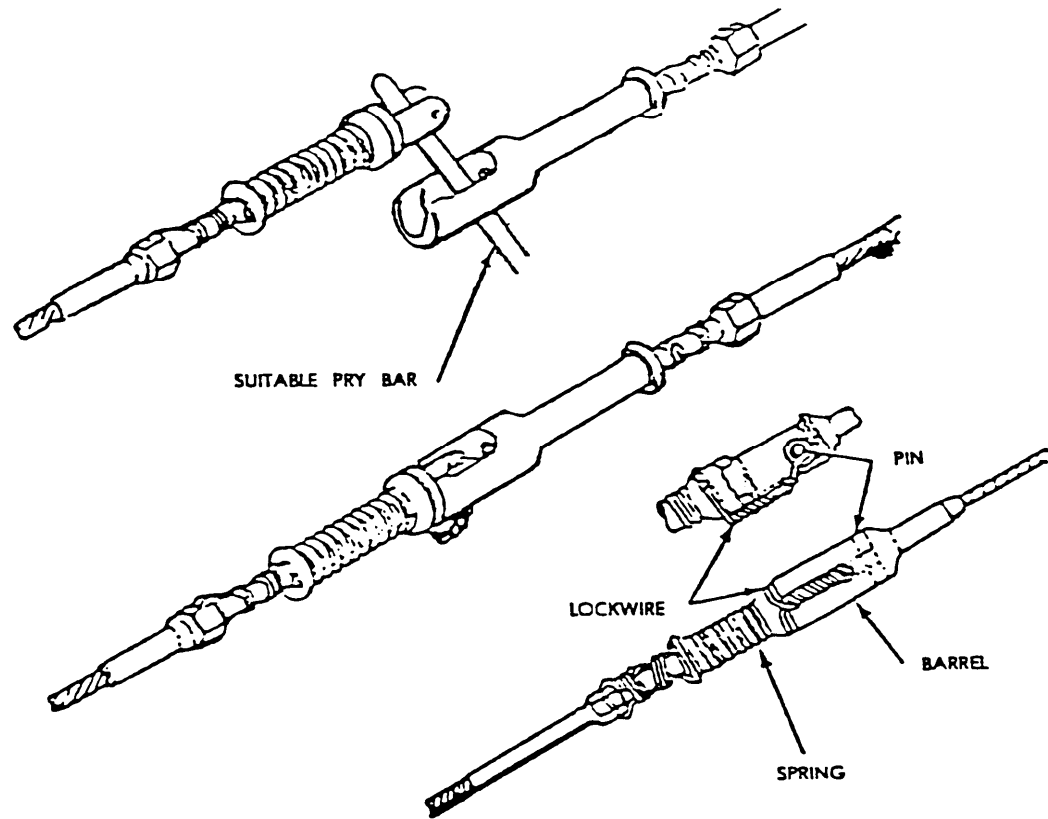

NOTE: Lockwire must go around pin, through hole in back of barrel, and around barrel groove.

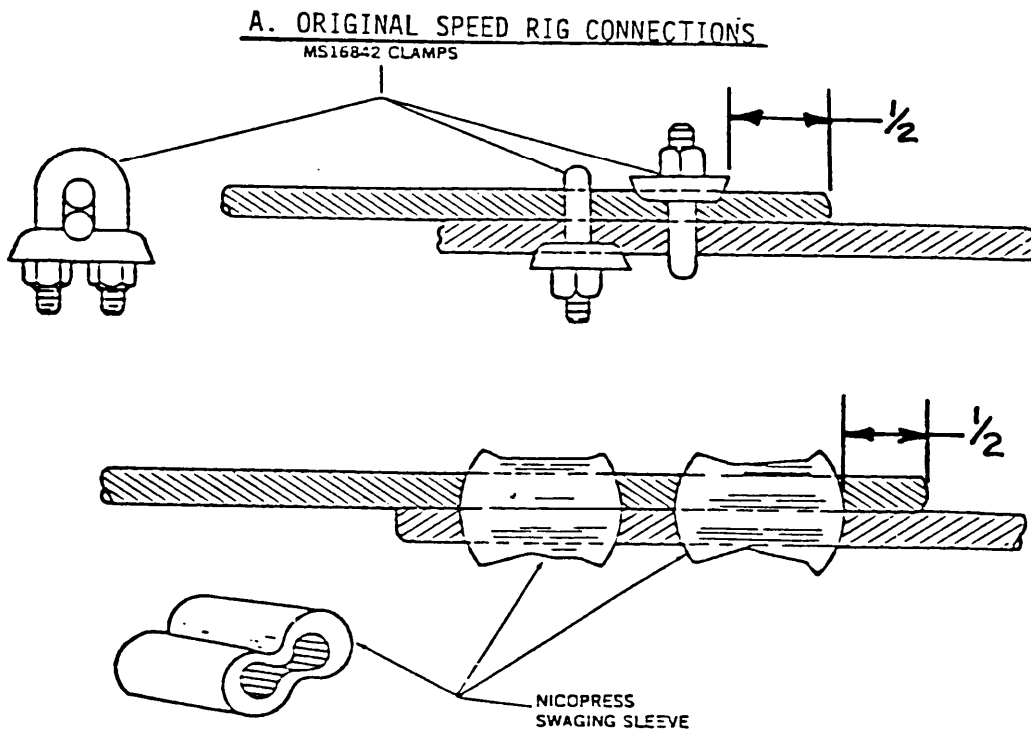
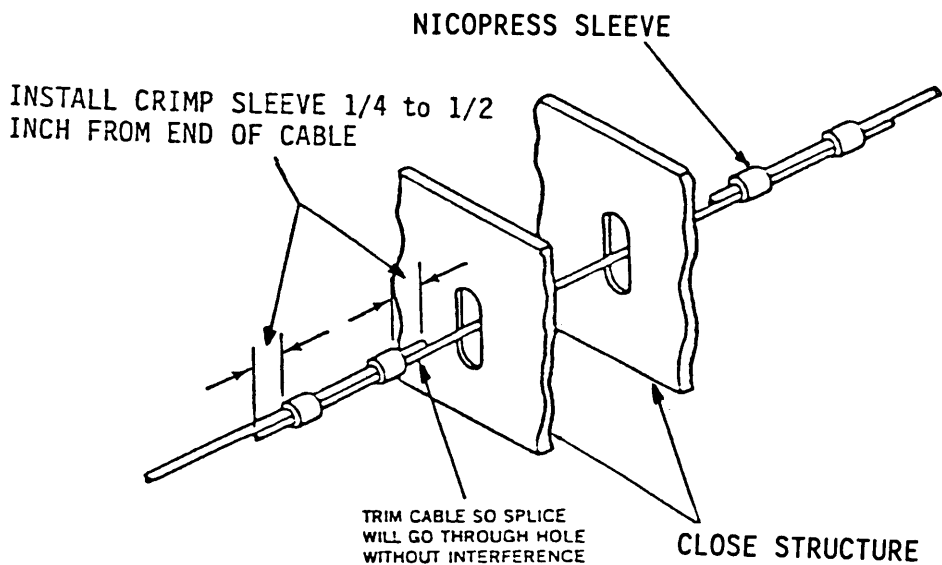
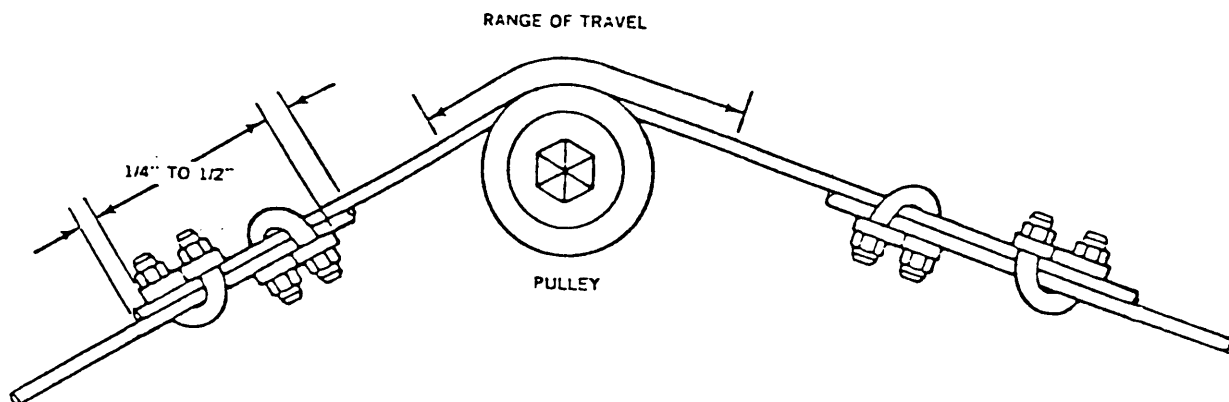

Figure 13-13. Clamp Splicing Control Cable (Sheet 1 of 2)



C. LOCATING SPLICES TO CLEAR STRUCTURE



D. LOCATING SPLICES TO CLEAR PULLEYS

Figure 13-13. Clamp Splicing Control Cable (Sheet 2 of 2)

CHAPTER 14
UTILITY SYSTEM
(NO BOAR REPAIRS TO SYSTEM)

CHAPTER 15
ENVIRONMENTAL CONTROL SYSTEM
(NO BDAR REPAIRS TO SYSTEM)

CHAPTER 16

HOIST AND WINCHES

(NO BDAR REPAIRS TO SYSTEM)

CHAPTER 17
AUXILIARY POWER PLANT
(not applicable)

CHAPTER 18
MISSION EQUIPMENT
(not applicable)

APPENDIX A

REFERENCES

**BDAR FIXES SHALL BE USED ONLY IN COMBAT OR FOR TRAINING
AT THE DISCRETION OF THE COMMANDER.
(AUTHORIZED TRAINING FIXES ARE LISTED IN APPENDIX E.)
IN EITHER CASE, DAMAGES SHALL BE REPAIRED BY STANDARD
PROCEDURES AS SOON AS PRACTICABLE.**

The following references of the issue in effect are required for use by repair personnel to accomplish the Instructions set forth in this TM.

PUBLICATION NUMBER	TITLE
AR 95-1.	Army Aviation Flight Regulations
AR 385-11.	Ionizing Radiation Protection
AR 708-1	Catalog Supply and Management Data
DA Form 2028	Recommend Changes to Publications
DA Form 2408-13	Aircraft Inspection and Maintenance Record
DA Form 2408-14	Uncorrected Fault Record
DA Form 2408-18	Equipment Inspection List
DA PAM 738-751	Functional User's Manual for the Army Maintenance Management System Aviation (TAMMS-A)
FM 1-202.	Environmental Flight
FM 3-5	NBC Decontamination
FM 10-68	Aircraft Refueling Field Manual
MIL-H-83797	General Specification for Medium Pressure Lightweight Rubber Hose
MIL-S-8516.	General Specification for Potting Compound Insulation Synthetic Rubber
SF 368	Quality Deficiency Report
TB 43-0108.	Handling, Storage, and Disposal of Army Aircraft Components Containing Radioactive Materials
TB MED 501.	Occupational and Environmental Health Hearing Conservation
TM 3-261.	Handling and Disposal of Unwanted Radioactive Materials

APPENDIX A (Cont)

TM 55-1500-204-25/1	General Aircraft Maintenance Manual
TM 55-1520-210-10	Operators Manual for UH-1H/V Helicopter
TM 55-1520-210-23	Aviation Unit and Intermediate Maintenance Instructions: Army Model UH-1D/H/EH-1H Helicopter
TM 55-1520-210-23P.	Aviation Unit and Intermediate Maintenance Repair Parts and Special Tools List (Including Depot Maintenance Repair Parts and Special Tools), Helicopter, Utility-Tactical Transport UH-1B, UH-1C, UH-1D, UH-1H, UH-1M, EH-1H (Bell)

APPENDIX B**SPECIAL TOOLS AND REPAIR KITS**

**BDAR FIXES SHALL BE USED ONLY IN COMBAT OR FOR TRAINING
AT THE DISCRETION OF THE COMMANDER.
(AUTHORIZED TRAINING FIXES ARE LISTED IN APPENDIX E.)
IN EITHER CASE, DAMAGES SHALL BE REPAIRED BY STANDARD
PROCEDURES AS SOON AS PRACTICABLE.**

Section 1. GENERAL

B-1. SCOPE. This appendix lists special tools and test equipment. Several special tools are contained in the BDAR kits listed on the next page. The kits also contain small quantities of parts and durable supplies not listed in other appendices. Each kit contains its own inventory list and tool usage instructions. There are no fabricated tools associated with this BDAR manual.

B-2. SPECIAL TOOLS AND REPAIR KITS LISTING. The items listed in this appendix will enhance crew members and mechanics at all levels to accomplish battlefield damage assessment and repairs.

Section I. SPECIAL TOOLS AND REPAIR KITS

ITEM NO.	NSN	DESCRIPTION
1	• Ž Ž	Composite Structures Repair Kit
2	5935-01-161-5883	Connector Repair Kit (Special Tools for Electrical Connector Repair) (11851) DMC658
3	4920-01-266-7535	Emergency Repair Kit (Special and Common Tools for Electrical Repair, Including Repair Parts) (11851) DMC895
4	4920-01-266-7534	Fluid Line Repair Kit (Special and Common Tools for Tubing and Hose Repair, Including Repair Parts) (78286) 70700-20900-041
5	• • •	Fuel Cell Repair Kit
6	5120-00-017-2849	Riveter, Blind, Hand (10054) 200
7	5120-00-224-9296	Riveter, Blind, Hand (25472) C6000-10-32
8	5120-00-979-7601	Riveter, Blind, Hand (03481) C6000-4-40
9	3540-01-117-7870	Sealing Iron, Electric (19836) 50-T
10	4920-01-266-7536	Test Equipment Repair Kit (Elec Test Equipment) (78286) 70700-20638-041
11	5935-01-254-1688	Wire Repair Kit (Special Tools Used for Electrical Wiring Repair, Including Repair Parts) (06090) MR-0015-1

Section II. TOOLS

This section lists tools recommended for support of the UH-1 helicopter in a combat environment.

Section II. TOOLS (Cont)

ITEM NO.	NATIONAL STOCK NUMBER	DESCRIPTION	U/I
1	5120-00-240-8702	Adapter, 1/2 to 3/8 inch	EA
2	5120-00-528-2891	Adapter, Apex 1/4 in. dr.	EA
3	5120-00-528-2892	Adapter, Apex 3/8 in. dr.	EA
4	5120-00-227-8095	Adapter, Socket 3/8 to 1/4 inch	EA
5	5120-00-223-8191	Awl, Saddlers Pad 4 inch.	EA
6	5120-00-221-1542	Awl, Scratch.	EA
7	5120-00-293-2503	Bar, Bucking Rivet, Angle Head Type 4 inch	EA
8	5120-00-293-2502	Bar, Bucking Rivet, L Head Type 4 inch.	EA
9	5120-00-293-2501	Bar, Bucking Rivet, Universal Type 4 inch.	EA
10	5210-00-919-2374	Bending Gage, Trim.	EA
11	5210-00-844-7757	Bender, Trim Tab M/R	EA
12	5120-00-240-0152	Bender, Tube, Hand, 1/4 inch	EA
13	5120-00-240-0153	Bender, Tube, Hand, 5/16 inch.	EA
14	5120-00-240-0154	Bender, Tube, Hand, 3/8 inch	EA
15	5120-00-240-0155	Bender, Tube, Hand, 1/2 inch	EA
16	5120-00-240-0156	Bender, Tube, Hand, 5/8 inch	EA
17	5120-00-240-0157	Bender, Tube, Hand, 3/4 inch	EA
18	5120-00-240-0158	Bender, Tube, Hand, 7/8 inch	EA
19	5110-00-927-1063	Blade, Hand, Flat (Tungsten)	EA
20	5110-00-277-4591	Blade, Hand Hacksaw	EA
21	5140-00-289-8910	Box, Tool, Steel Mechanic Type 10X1-2X22X13.	EA
22	5210-00-263-0376	Caliper, 8 inch.	EA
23	5110-00-242-3457	Chisel, Cold Hand 3/8 inch.	EA
24	5110-00-234-1927	Chisel, Cold Hand Steel 1/4 in. Cut 4 in. long	EA
25	5110-00-186-7107	Chisel, Cold Hand Type 1/2 in. Cut 5 3/4 in. long.	EA
26	5120-00-061-1273	Clamp, "C" 1 inch.	EA
27	5120-00-203-6439	Clamp, "C" 2 1/2 inch.	EA
28	5120-00-180-0905	Clamp, "C" 2 3/4 inch.	EA
29	5120-00-180-0908	Clamp, "C" 4 inch.	EA
30	5120-00-203-6431	Clamp, "C" 6 inch.	EA
31	7910-00-857-1042	Cleaner, Vacuum	
32	5120-00-242-3789	CLECO, 3/32 inch.	
33	5120-00-222-3336	CLECO, 5/32 inch.	
34	5120-00-242-3791	CLECO, 3/16 inch.	
35	5120-00-541-1808	CLECO, 1/8 inch.	
36	5120-00-253-3882	CLECO, 1/4 inch.	12EA
37	CLECO, Clamps, P/N 00784EL-1/2-1	EA
38	5133-00-293-1902	Countersink 3/8 in. Body 1/4 in. Shank	EA
39	5133-00-243-2298	Countersink 7/16 in. Body 1/8 in. Pilot.	EA
40	5133-00-243-2300	Countersink 7/16 in. Body 3/16 in. Pilot	EA
41	5133-00-243-2299	Countersink 7/16 in. Body 5/32 in. Pilot	EA
42	5120-00-278-2423	Crimping, Tool Large.	EA
43	5120-01-120-8721	Crimping, Tool, AD-1377.	EA
44	5120-00-170-7938	Crimping, Tool Hand.	EA

Section II. TOOLS (Cont)

ITEM NO.	NATIONAL STOCK NUMBER	DESCRIPTION	U/I
45	5120-00-184-8410	Crow Foot, 3/8 dr. X 1 3/8 flat.	EA
46	5120-00-184-8414	Crow Foot, 3/8 dr. X 1 5/8 flat.	EA
47	5120-00-184-8412	Crow Foot, 3/8 dr. X 1 1/2 flat.	EA
48	5120-00-184-8409	Crow Foot, 3/8 dr. X 1 5/16 flat.	EA
49	5120-00-517-7021	Crow Foot, 3/8 dr. X 1 1/8 flat.	EA
50	5120-00-184-8403	Crow Foot, 3/8 dr. X 1 5/16 flat.	EA
51	5120-00-184-8401	Crow Foot, 3/8 dr. X 1 3/16 flat.	EA
52	5120-00-184-8398	Crow Foot, 3/8 dr. X 5/8 flat.	EA
53	5120-00-184-8384	Crow Foot, 3/8 dr. X 1/2 flat.	EA
54	5120-00-184-8400	Crow Foot, 3/8 dr. X 3/4 flat.	EA
55	5120-00-184-8397	Crow Foot, 3/8 dr. X 9/16 flat.	EA
56	5120-00-236-2261	Crow Foot, 3/8 dr. X 1 1/16 flat.	EA
57	5120-00-184-8383	Crow Foot, 3/8 dr. X 7/16 flat.	EA
58	5120-00-293-2567	Crow Foot, 3/8 dr. X 1 1/4 flat.	EA
59	5120-00-239-8253	Cutter, Diagonal, 6 in.	EA
60	. . .	Cutter, Diagonal, 7 in. Heavy Duty, P/N 93389209	EA
61	5110-00-180-2892	Cutter, Rivet Squeeze Type	EA
62	5120-00-287-6720	Cutter, Tubing.	EA
63	5136-00-197-9296	Die, Round 1/4-28, 2 in. O.D.	EA
64	6625-01-139-2512	Digital Multimeter, Simpson MOD 407.	EA
65		Disk, Holding 1 inch, P/N 00179741C1	
66	5210-00-263-0376	Dividers, Mechanics 8 inch	EA
67	5133-00-449-6775	Drill, Bit Set Twist No. 1 thru No. 60 with Case	EA
68	5110-00-293-3411	Drill, Hand, Type I.	EA
69	5130-00-294-9511	Drill, Pneu. 1/4 in. Chuck.	EA
70	. . .	Drill, Stop 1/8 inch, P/N 00784AT570-28.	EA
71	. . .	Drill, Stop 5/32 inch, P/N 09784AT570-21	EA
72	5120-01-094-0027	Drill, Stop 3/32 inch	EA
73	5133-01-105-6772	Drill, Stop 3/16 inch	EA
74	. . .	Drill and Screw Driver, Bat. Operated.	EA
75	5120-00-243-7325	Extension, 1/4 dr. 6 inch.	EA
76	5120-00-243-1693	Extension, 3/8 dr. 9 inch.	EA
77	5120-00-227-8105	Extension, Socket 1/4 in. dr. 2 inch	EA
78	5120-00-357-5853	Extractor Set, Screw Sz. 1 thru 6.	EA
79	5120-00-222-4248	Extractor, Cotter Pin.	EA
80	5110-00-241-9150	File, Half Round Bastard Cut 8 inch.	EA
81	5110-00-241-9152	File, Half Round Smooth Cut 8 inch	EA
82	5110-00-249-2849	File, Hand Flat Bastard 10 inch.	EA
83	5110-00-234-6532	File, Hand Flat 5/8 in. Wide Smooth Cut 6 inches	EA
84	5110-00-234-6551	File, Hand Round Bastard Cut 8 inches.	EA
85	5110-00-241-9138	File, Hand Smooth Cut 10 inches.	EA
86	5110-00-249-2847	File, Hand Type Bastard 6 in. long	EA
87	3455-00-187-2560	File, Rot. Hss. No. 1, Coarse Cut	EA
88	5110-00-234-6549	File, Rnd. Reg. Cut 6 inches	EA

Section II. TOOLS (Cont)

ITEM NO.	NATIONAL STOCK NUMBER	DESCRIPTION	U/I
89	5120-00-180-2951	Finger, Mech. Flexible 24 inches	EA
90	3643-00-517-1043	Fixture, Locating & Drill 3/16 dia	EA
91	3463-00-517-1044	Fixture, Locating & Drill 1/8 dia	EA
92	5120-00-251-2267	Flaring Tool	EA
93	6320-00-299-3035	Flashlight, Explosion Proof, 3 Cell	EA
94	5110-00-289-9657	Frame, Hacksaw Adjustable 10 to 12 Inch.	EA
95	5210-00-221-1902	Gage, Depth.	EA
96	5210-00-221-1893	Gage, Drill 1 to 60.	EA
97	5210-00-221-2448	Gage, Rnd. Sheetmetal Thickness.	EA
98	5210-00-246-2303	Gage, Thickness.	EA
99	5210-00-221-2451	Gage, Wire 0-36.	EA
100	5130-00-293-2797	Grinder, Pneu. Horizontal	
101	5120-00-494-1910	Grips, Vice Curved Jaw 7 inch.	
102	4930-00-025-2478	Gun, Grease	
103	4940-00-785-1162	Gun, Heat Electric Portable.	
104	5120-00-061-8542	Hammer, Ball Peen 12 oz.	
105	5120-00-061-8543	Hammer, Ball Peen 16 oz.	
106	5120-00-250-3911	Hammer, Ball Peen 20 oz.	EA
107	5120-00-221-7940	Handle, Hinged 1/4 in. dr.	EA
108	5120-00-240-5396	Handle, Ratchet 3/8 in. dr.	EA
109	5120-00-240-1418	Handle, Spin 1/4 in. dr.	
110	5120-00-221-7957	Handle, Socket Ratchet 1/4 in. dr.	
111	5120-00-331-5502	Holder, Aprx. 3/8 dr. 5/16 in. Sz. Bit	
112	3460-00-847-5135	Holder, Countersink Adj	
113	5120-00-242-3791	Holder, Hole Spring Type Tension Cleco 3/16	
114	5120-00-197-5344	Holder, Sheet Metal Cleco Edge Clamp	
115	5120-00-568-0401	Installation Tool, Hand Operated Jo-Bolt	
116	5120-00-243-1686	Joint Univ. Socket 1/4 dr.	
117	5110-00-595-9244	Key Set 11pc sz. 0 to 53 3/8 in. sizes	
118	5110-00-240-5943	Knife, Pocket Electricians with Screwdriver Blade.	
119	5120-00-221-1536	Knife, Putty Flex. 1 1/4 in. Blade	
120	5120-00-293-3397	Mallet, Rawhide 1 1/2 in. dia.	
121	5210-00-601-9421	Measuring Tape 16 ft.	
122	5120-00-892-5709	Mirror, Round Large.	
123	5120-00-089-3663	Nut Driver Set, Xcelite 3/16 to 9/16	
124	5120-00-595-9545	Pliers, Cannon Plug 8 in.	
125	5120-00-278-0352	Pliers, Channel Locks 10 In.	EA
126	5110-00-222-2708	Pliers, Diagonal Cut Reg. Nose 7 1/2 in. size.	EA
127	5120-00-595-9519	Pliers, Duck Bill.	EA
128	5120-00-239-8250	Pliers, Needle Nose Curved Round	EA
129	5120-00-184-9403	Pliers, Needle Nose 6 1/2 in. size	EA
130	5120-00-221-1597	Pliers, Sheet-Metal Cleco Holder 8 in. size.	EA
131	5120-00-494-1889	Pliers, Sheet-Metal Vise Grips w/Wide Jaw 8 in	EA
132	5120-00-624-8065	Pliers, Slip Joint Conduit 9 in.	EA
133	5120-00-170-7983	Pliers, Stakon Long Crimp 9 3/4 in	EA
134	5120-00-494-1911	Pliers, Vise Grips 8 1/2 in.	EA

Section II. TOOLS (Cont)

ITEM NO.	NATIONAL STOCK NUMBER	DESCRIPTION	U/I
135	5120-00-223-7396	Pliers, Wrench Straight Jaw 8 in	
136	5140-00-329-4306	Pouch, Tool Mech Canvas.	
137	5120-00-102-6847	Puller, Riv-Nut size 1/4-28.	
138	5120-00-060-2135	Puller, Riv-Nut size 6/32.	
139	5120-00-293-3509	Punch, Center Solid Stock 5/32 in dia tip.	
140	5120-00-240-6083	Punch, Drive Pin 1/4 in. Point	
141	5120-00-242-3433	Punch, Drive Pin 1/8 in. Point	
142	5120-00-240-6106	Punch, Drive Pin 3/16 in. Point.	
143	5120-00-242-3435	Punch, Drive Pin 3/32 in. Point.	
144	5120-00-240-6104	Punch, Drive Pin 5/32 in. Point.	
145	5120-00-240-5364	Racet, 3/8 in. dr	
146	4931-01-119-7103	Repair Kit, Electrical Connector, P/N 12205360	
147	5120-00-017-2849	Riveter, Blind Hand	
148	5120-00-017-2849	Riveter, Blind Hand	
149	5120-00-979-7601	Riveter, Blind Hand	
150	5120-00-224-9296	Riveter, Blind Hand	
151	5130-01-044-7207	Riveter, Pneu. Cherry Rivet.	
152	Riveter, Pneu. Portable 3/16 In, 119764X	
153	5130-00-241-3482	Riveter, Pneu. 3/32 in	
154	Rivet Gun	
155	5130-00-529-0927	Rivet, Set 8T107&2	
156	Router Bit, 3/16 in, P/N 89684310005	
157	3230-01-157-4422	Router Bit, No 1.	
158	5210-00-234-5223	Rule, Mach. Steel	
159	5120-00-305-2306	Safety Wire pliers	
160	3455-00-335-3036	Saw Hole.	
161	5110-00-255-0420	Scissors, Electricians	
162	5120-00-222-8852	Screwdriver, Common 1/4 X 4 in	
163	5120-00-260-4837	Screwdriver, Common 8 in	
164	5120-00-288-8739	Screwdriver, Jewelers.	
165	5120-00-529-3101	Screwdriver, Phillips 12 inch.	EA
166	5120-00-240-8716	Screwdriver, 3 In. Philips No. 1	EA
167	5120-00-227-7362	Screwdriver, 3/8 dr., 3/8 Tip, 12 in. long	EA
168	5120-00-227-7293	Screwdriver, 1 1/2 in. Phillips No. 2.	EA
169	5120-00-234-8910	Screwdriver, 5/16 in. Tip, Common 6 in. long	EA
170	5120-00-234-8912	Screwdriver, 6 in. Phillips No. 3.	EA
171	5120-00-596-1543	Scribe, Mach Dbl. Point 8 to 9 in. long.	EA
172	5130-00-596-4284	Set Rivet, Flush Type 3/4 inch	EA
173	5130-00-233-6492	Set Rivet, Univ HD 3/16 Inch	EA
174	5110-00-273-0126	Shears, Metal Cutting L/H 10 1/2 inch.	EA
175	5110-00-273-0127	Shears, Metal Cutting R/H 10 1/2 inch.	EA
176	5110-00-273-0128	Shears, Str. Cut Light Duty 10 inch.	EA
177	5110-00-293-0089	Shears, Str. Cut Light Duty 12 1/2 inch.	EA
178	5210-00-078-8947	Square, Combination 12 inch.	EA
179	5120-00-087-0697	Socket, 12 pt. 1/4 dr. 1/2 in. deep.	
180	5120-00-235-5807	Socket, 12 pt. 3/8 dr. 13/16 in. sh.	

Section II. TOOLS (Cont)

ITEM NO.	NATIONAL STOCK NUMBER	DESCRIPTION	u/l
181	5120-00-775-6983	Socket, 12 pt. 1/4 dr. 1/4 in. deep.	
182	5120-00-888-6120	Socket, 12 pt. 1/4 dr. 11/32 in. deep.	
183	5120-00-242-3351	Socket, 12 pt. 1/4 dr. 11/32 in. sh.	
184	5120-00-775-6981	Socket, 12 pt. 1/4 dr. 3/16 in. deep.	
185	5120-00-242-3352	Socket, 12 pt. 1/4 dr. 3/8 in. deep.	
186	5120-00-235-5878	Socket, 12 pt. 1/4 dr. 5/16 in. sh.	
187	5120-00-235-5822	Socket, 12 pt. 1/4 dr. 5/16 in. deep.	
188	5120-00-775-6980	Socket, 12 pt. 1/4 dr. 7/16 in. deep.	
189	5120-00-235-5869	Socket, 12 pt. 1/4 dr. 7/16 in. sh.	
190	5120-00-189-8610	Socket, 12 pt. 1/4 dr. 1/2 in. sh.	
191	5120-00-236-2264	Socket, 6 pt. 1/4 dr. 1/4 in. sh.	
192	5120-00-236-2262	Socket, 6 pt. 1/4 dr. 3/16 in. sh.	
193	5120-00-189-7922	Socket, 6 pt. 1/4 dr. 3/8 in. deep.	
194	5120-00-236-2263	Socket, 6 pt. 1/4 dr. 7/32 in. sh.	
195	5120-00-242-3345	Socket, 6 pt. 1/4 dr. 9/32 in. sh.	
196	5120-00-227-1033	Socket, 6 pt. 3/8 dr. 3/8 in. deep.	
197	5120-00-293-0163	Socket, 6 pt. 3/8 dr. 3/8 in. sh.	
198	. . .	Socket, 6 pt. 3/8 dr. 1/2 in. deep.	
199	5120-00-203-6446	Socket, 6 pt. 3/8 dr. 1/2 in. sh.	
200	. . .	Socket, 6 pt. 3/8 dr. 7/16 in. deep.	
201	5120-00-880-9970	Socket, 6 pt. 3/8 dr. 7/16 in. sh.	
202	5120-00-165-4097	Socket, 6 pt. 3/8 dr. 9/16 in. deep.	
203	. . .	Socket, 6 pt. 3/8 dr. 9/16 in. sh.	
204	. . .	Socket, 6 pt. 3/8 dr. 5/8 in. sh.	
205	5120-00-232-5706	Socket, 12 pt. 3/8 dr. 11/16 in. sh.	
206	. . .	Socket, 6 pt. 3/8 dr. 11/16 in. deep, P/N 557195SFS221	
207	5120-01-091-0690	Socket, 6 pt. 3/8 dr. 3/4 in. deep.	
208	5120-00-227-6705	Socket, 12 pt. 3/8 dr. 3/4 in. sh.	
209	5120-00-242-3330	Socket, 12 pt. 3/8 dr. 7/8 in. sh.	
210	5120-00-720-1350	Socket, 6 pt. 3/8 dr. 7/8 in. sh.	
211	5120-01-119-3205	Socket, 6 pt. 3/8 dr. 13/16 in. deep.	
212	5120-00-116-9466	Socket, 6 pt. 1/2 dr. 15/16 in. sh.	
213	5120-00-227-6696	Socket, 6 pt. 1/2 dr. 1 in. sh.	
214	. . .	Socket, 6 pt. 1/2 dr. 1 1/8 in. sh, P/N 09669743414	
215	5120-00-178-0806	Socket, 6 pt. 1/2 dr. 1 1/4 in. sh.	
216	5120-00-177-7068	Socket, 6 pt. 3/4 dr. 7/8 in. deep.	
217	3439-00-264-9573	Soldering Iron Bat. Operated	EA
218	5110-00-803-6339	Splitting Tool, Nut 7/8 in. cap.	EA
219	6625-01-102-6878	TA-1 Continuity and Test Probe Kit, P/N 123036622.	
220	5136-00-729-5700	Tap, Hand Thread 10/32	EA
221	5136-00-227-8618	Tap, Hand Thread 1/4 X 28.	EA
222	5136-00-729-5695	Tap, Hand Thread 6/32	EA
223	5136-00-729-5694	Tap, Hand Thread 8/32	EA
224	5120-00-781-7981	Tie Wrap Gun.	EA
225	5140-00-498-8772	Tool Box, Portable, Steel with Removable Tray.	
226	5120-01-128-5511	Tool Set, Supplement, Organizational	

APPENDIX C

EXPENDABLE/DURABLE SUPPLIES AND MATERIALS LIST

**BDAR FIXES SHALL BE USED ONLY IN COMBAT OR FOR TRAINING
AT THE DISCRETION OF THE COMMANDER.
(AUTHORIZED TRAINING FIXES ARE LISTED IN APPENDIX E.)
IN EITHER CASE, DAMAGES SHALL BE REPAIRED BY STANDARD
PROCEDURES AS SOON AS PRACTICABLE.**

Section I. INTRODUCTION

C-1. SCOPE. This appendix lists expendable supplies and materials needed to make BDAR fixes on the UH-1H/V helicopter. Items are listed alphabetically by the item shown in the description column. These items are authorized to you by CTA 50-970, Expendable Items (Except Medical, Class V, Repair Parts, and Heraldic Items) or CTA 8-100.

C-2. EXPLANATION OF COLUMNS.

a. Item Number. This number is assigned to the entry in the listing and is referenced in the narrative instructions to identify the material (e.g., "Use cleaning compound, item 5, Appendix C").

b. National Stock Number. This is the National stock number assigned to the item; use it to request or requisition the item.

c. Description. Indicates the Federal item name and, if required, a description to identify the item. The last line for each item indicates the Commercial and Government Entity Code (CAGEC) in parentheses followed by the part number.

d. Unit of Issue (U/I). Is the abbreviation of the types of units under which material is issued.

APPENDIX C

Section II. EXPENDABLE SUPPLIES AND MATERIALS LIST

ITEM NUMBER	NSN	DESCRIPTION	UNIT OF ISSUE
1	6810-00-223-2739	Acetone, Technical (81348) O-A-51	PT
2	6810-00-184-4796	Acetone, O-A-51, (81348)	CN
3	8040-00-162-9704	Adhesive, Epoxy (16059) Z-T014 (30 Min Cure)	KT
4	8040-00-264-6816	Adhesive, 5-Minute Epoxy (16059) P/N 14210	KT
5	8040-01-293-2686	Adhesive Repair Kit (16059) 72250 (Zip-Patch)	KT
6	8040-01-089-9073	Adhesive, Epoxy (Blade Repair) (33564) EA9330	CN
7	8040-01-102-2098	Adhesive, Epoxy (Blade Repair) (33564) EA934NA	CN
8	8040-00-944-7292	Adhesive, Epoxy Metal Set A4 (33564) EA9340	CN
9	8040-00-165-8614	Adhesive, General Purpose (81348) MMM-A-121	TU
10	8040-00-941-9984	Adhesive, Silicone Rubber (80244) MIL-A-46106, Type I	TU
11	5306-00-141-4511	Bolt (88044) AN173H20A	BX
12	5306-00-150-9083	Bolt (88044) AN173H10	BX
13	5306-00-156-2533	Bolt (88044) AN173H6A	BX
14	5306-00-180-2756	Bolt (88044) AN5H17, 5/16-24 X 1-1/2	HD
15	5306-00-182-1529	Bolt (88044) AN4H11, 1/4-28 X 1-1/8	HD
16	5306-00-206-4911	Bolt (88044) AN173H15A	BX
17	5306-00-292-8284	Bolt (88044) AN173H4A	BX
18	5306-00-582-5723	Bolt (80205) NAS1305-8	BX
19	5306-00-616-6471	Bolt (80205) NAS1304-10	BX
20	5306-00-619-2178	Bolt (80205) NAS1303-8	EA
21	5306-00-655-7443	Bolt (80205) NAS1304-8	BX
22	5306-00-680-5285	Bolt (80205) NAS1303-6	EA
23	5306-00-722-1788	Bolt (80205) NAS1304-6	HD
24	5306-00-774-8915	Bolt (80205) NAS1305-6	BX
25	5306-00-806-7697	Bolt (80205) NAS1305-4	BX
26	5306-00-807-2958	Bolt (80205) NAS1304-4H	EA
27	5306-00-816-0948	Bolt (80205) NAS1305-10	BX
28	5306-01-074-2075	Bolt (80205) NAS1303-10	HD
29	5306-01-107-1224	Bolt (80205) NAS1303-4	HD
30	7920-00-514-2417	Brush, Stiff Fiber Bristle (80244) H-B-643	EA
31	5975-00-156-3253	Cable, Tie, Elec (81349) MIL-S-23190	EA
32	5975-00-984-6582	Cable Tie, Elec (81349) MIL-S-23190	EA

APPENDIX C

Section II. EXPENDABLE SUPPLIES AND MATERIALS LIST (Cont)

ITEM NUMBER	NSN	DESCRIPTION	UNIT OF ISSUE
33	5940-00-280-3499	Cap, Elec Crimp (96906) MS25274-2	EA
34	5979-00-729-1628	Cap, Elec Crimp 14/16 AWG (Blue) (81349) MIL-T-7928	PG
35	. . .	Cement, Repair Kit (25500) (3 part cartridge kit) Semkit-GAC P/N 324-3-47178	KT
36	8030-00-057-2354	Chemical Conversion Coating (Alodine) (80244) MIL-C-81706	GL
37	4730-00-087-0831	Clamp, Hose (9/16 to 15/16) (88044) AN737TW24-30	EA
38	4730-00-203-3132	Clamp, Hose (13/16 to 1-1/16) (88044) AN737TW34-38	EA
39	4730-01-048-3532	Clamp, Hose (61/64 to 1-1/2) (08484) AN737TW44-48	EA
40	4730-00-289-5909	Clamp, Hose, (1-21/64 to 2-1/16) (08484) AN737TW56-66	EA
41	4730-00-908-3193	Clamp, Hose, (1-7/7 to 2-27/32) (08484) AN737TW74-91	EA
42	4730-00-203-3132	Clamp, Hose (2-5/8 to 3-9/16) (31610) AN 737 TW98-114	EA
43	5340-00-720-8863	Clamp, Mechanical (22337) (Patch) CFD212E, Size 5	EA
44	5340-00-720-8864	Clamp, Mechanical (22337) (Patch) CFD212E, Size 3	EA
45	8030-00-231-2345	Corrosion Preventive Compound (80244) MIL-C-16173	CN
46	5310-00-297-3751	Cotter Pin Assortment (81348)	KT
47	9540-00-140-2401	Extrusion Angle 2X1X0.125 (81348) QQ-A-200/9	FT
48	9540-00-140-2417	Extrusion Angle 1-1/2XI-1/2 X 0.125 (81348) QQ-A-200/11	FT
49	9540-00-145-4524	Extrusion Angle 1-1/4X3/4 X 0.063 (81348) QQ-A-200/3	FT
50	9540-00-145-5716	Extrusion Angle 1-3/4XI-1/2 X 0.156 (81348) QQ-A-200/11	FT
51	9540-00-145-7542	Extrusion Angle 2X1X0.156 (81348) QQ-A-200/11	FT
52	9540-00-145-7543	Extrusion Angle 2X1-1/2 X 0.125 (81348) QQ-A-200/3	FT
53	9540-00-288-3740	Extrusion Angle 3 X 3 X 0.250 (81348) QQ-A-200/11 (T6)	FT
54	9540-00-230-2338	Extrusion Angle 1-1/2XI-1/2 X 0.188 (81348) QQ-A-200/11	FT
55	9540-00-236-5240	Extrusion Angle 3X1-1/2 X 0.250 (81348) QQ-A-200/11	FT

APPENDIX C

Section II. EXPENDABLE SUPPLIES AND MATERIALS LIST (Cont)

ITEM NUMBER	NSN	DESCRIPTION	UNIT OF ISSUE
56	9540-00-596-3006	Extrusion Angle 1-1/2 X 1/4 X 0.094 (81348) QQ-A-200/11	FT
57	9540-00-854-6554	Extrusion Angle 2X2 X 0.250 (81348) QQ-A-200/	FT
58	9540-00-931-7261	Extrusion Angle 2X2 X 0.188 (81348) QQ-A-200/3	FT
59	9540-00-933-9650	Extrusion Angle 1-1/2X1-1/2 X 0.094 (81348) QQ-A-200/3	FT
60	9540-00-596-3016	Extrusion, L Angle 2024T-4 0.063 (81348) QQ-A-267	FT
61	9540-00-555-1172	Extrusion, T Angle 2024T-4 0.063 (81348) QQ-A-200/3	FT
62	5940-00-296-5326	Ferrul, Electrical, 22-14 Wire Gage size (10 ea) (59730)	EA
63	8305-00-530-0109	Fiberglass Cloth (81349) MIL-C-9084	RO
64	8305-00-530-0111	Fiberglass Resin (81349) MIL-C-9084	CN
65	5330-00-467-3615	Gasket, Paper Filer 1/32 In. (81348) HH-P-96	SH
66	5970-00-032-0291	Heat Shrink Sleeve Assortment (61521) DI-295-MS-1	KT
67	4730-00-203-3131	Hose Clamp (66295) AN737TW57-66	EA
68	4730-00-278-9200	Hose Clamp (66295) AN737TW22	EA
69	4730-00-279-0065	Hose Clamp (08484) QS200M1200	EA
70	4730-00-541-7747	Hose Clamp (66295) AN737TW74-91	EA
71	4730-00-720-0167	Hose Clamp (88044) AN737TW30	EA
72	4730-00-908-6292	Hose Clamp (88044) AN737RM98	EA
73	9505-00-596-5101	Lockwire, Steel 0.020 (81348) QQ-W-423	RO
74	9505-00-293-4208	Lockwire, Steel 0.032 (81348) QQ-W-423	RO
75	9505-00-331-3275	Lockwire, Steel 0.041 (81348) QQ-W-423	RO
76	6810-00-238-8119	Naptha, Aliphatic (81348) TTN95	GL
77	5310-00-297-3751	Nut Assortment (81348) FFN836	PG
78	5310-00-807-1467	Nut (80205) NAS1291X3	BX
79	5310-00-807-1469	Nut (21450) 503443	BX
80	5310-00-807-1474	Nut (80205) NAS679A3	BX
81	5310-00-807-1475	Nut (96906) MS21042L4	BX
82	5310-00-680-7105	Nut, Self-Lock Steel 5/16 (80205) NAS 679C5M	EA

APPENDIX C

Section II. EXPENDABLE SUPPLIES AND MATERIALS LIST (Cont)

ITEM NUMBER	NSN	DESCRIPTION	UNIT OF ISSUE
83	5310-00-807-1474	Nut, Self-Lock Steel 3/16 in (80205) NAS679A3	HD
84	5310-00-844-4872	Nut, Self-Lock Steel 1/4 in (80205) NAS67904	HD
85	5310-00-071-8390	Nut, Self-Locking (96906) MS17825-4, 1/4-28	EA
86	5310-00-900-9421	Nut, Self-Locking (96906) MS17825-5, 5/16-24	EA
87	5330-00-966-8657	Packing, Preformed Assortment (51808) MAOK311	PG
88	9150-00-250-0926	Petrolatum, Technical (81349) VV-P-236	CN
89	8030-00-616-7696	Potting Compound, Electrical (81349) MIL-S-8516	KT
90	8030-00-664-4968	Putty, Chromate (81349) MIL-P-8116	RO
91	. . .	Repair Fabric (25500) GAC CODE 290 N, 12 oz. Nylon, EA as one sq. yd.	EA
92	6810-00-995-4804	Resin Activator (22527) 4573T	KT
93	5905-00-901-9520	Resistor, Fixed Composition 51 ohm (81349) 63A5A68-510	EA
94	5320-00-006-4912	Rivet, Blind (92215) RV1100-4-3 (.139/.143 Shank Dia)	BX
95	5320-00-117-6826	Rivet, Blind (96906) MS2040AD4-4 (1/8 Nominal)	BX
96	5320-01-033-8177	Rivet, Blind, Cherry Max 5-2 (81349) MIL-R-788516 (.173/.176 Shank Dia)	EA
97	5320-01-033-8178	Rivet, Blind, Cherry Max 5-6 (81349) MIL-R-7885/6 (.173/.176 Shank Dia)	EA
98	5320-01-033-8179	Rivet, Blind (81349) MIL-R-7885/6	BX
99	5320-01-033-8642	Rivet, Blind, CR3243-4-3 (11815), 1/8 Nominal	HD
100	5320-01-033-9127	Rivet, Blind, CR3243-4-2 (11815), 1/8 Nominal	HD
101	5320-01-033-9128	Rivet Blind, CR3243-4-4 (11815), 1/8 Nominal	HD
102	5320-01-033-9663	Rivet Blind, CR3243-4-5 (11815), 1/8 Nominal	HD
103	5320-01-041-6454	Rivet, Blind (11815) CR3553-5-2 (.172/.176 Shank Dia)	EA
104	5320-01-041-6458	Rivet, Blind, CR3553-6-6 (96906) MS7885/8-6-6 (.201/.205 Shank Dia)	EA

APPENDIX C

Section II. EXPENDABLE SUPPLIES AND MATERIALS LIST (Cont)

ITEM NUMBER	NSN	DESCRIPTION	UNIT OF ISSUE
105	5320-01-042-2891	Rivet, Blind (7652) CR3553-5-6 (.172/.176 Shank Dia)	EA
106	5320-01-042-8250	Rivet, Blind (F7652) CR3553-6-4 (.201/.205 Shank Dia)	EA
107	5320-01-042-8893	Rivet, Blind (F7652) CR3553-6-2 (.201/.205 Shank Dia)	EA
108	5320-01-043-6694	Rivet, Blind (F7652) CR3553-5-4 (.172/.176 Shank Dia)	EA
109	5320-01-084-9234	Rivet, Blind, Cherrymax 6-6 (81349) MIL-R-7885/2 (.188/.192 Shank Dia)	EA
110	5320-01-084-9235	Rivet, Blind (81349) MIL-R-7885/2-6-05 (.188/.192 Shank Dia)	EA
111	5320-01-084-9236	Rivet, Blind (11815) CR3213-6-11 (.188/.192 Shank Dia)	EA
112	5320-01-085-9995	Rivet, Blind, Cherrymax (11815) CR3213-6-7 (.188/.192 Shank Dia)	EA
113	5320-01-135-7319	Rivet, Blind, Cherrymax 6-3 (81349) MIL-R-7885/2 (.188/.192 Shank Dia)	EA
114	5320-01-136-1782	Rivet, Blind, Cherrymax 6-4 (81349) MIL-R-7885/2	EA
115	9320-00-241-9747	Rubber Sheet (81349) MIL-R-6855 3/16 in. thick	SH
116	9320-00-291-8468	Rubber Sheet (22337) PF10056, 1/32 in. thick	SH
117	9320-01-117-1964	Rubber Sheet (81349) MIL-R-6855, 1/8 in. thick	SH
118	5330-00-224-7201	Abrasive Paper 400 Grit (81348) P-P-101	SH
119	5350-00-224-7203	Abrasive Paper 320 Grit (81348) P-P-101	SH
120	5350-00-619-9167	Abrasive Paper 80 Grit (81348) P-P-101	SH
121	5350-00-721-8117	Abrasive Paper 180 Grit (81348) P-P-101	SH
122	5330-01-060-8212	Abrasive Paper 600 Grit (98747) 7530179-50	SH
123	5305-00-206-2036	Screws, Wood (81348) FF-S-85	BX

APPENDIX C

Section II. EXPENDABLE SUPPLIES AND MATERIALS LIST (Cont)

ITEM NUMBER	NSN	DESCRIPTION	UNIT OF ISSUE
124	8030-00-881-5238	Sealant and Puttying Compound (81349) MIL-S-8516	KT
125	8030-00-935-1083	Sealant, Asphalt Base (81349)	CN
126	8030-00-965-2004	Sealant, Synthetic Rubber (81349) MIL-S-8802	KT
127	8030-00-656-1426	Sealing Compound, Gasket Non-Hardening (81349) MIL-S-45180	PT
128	8030-00-723-2746	Sealing Compound, Pro-Seal 890 (81349) MIL-S-7502	QT
129	9535-00-167-2280	Sheet Metal, 0.040 2024-T3 (81348) QQ-A-250/5	SH
130	9535-00-224-7032	Sheet Metal, .020 in, 2024-T3	SH
131	9515-00-231-8601	Sheet Metal, 0.032 Stainless (81349) MIL-S-5059	SH
132	9535-00-232-0383	Sheet Metal, 0.071 2024-T3 (81348) QQ-A-250/5	SH
133	9535-00-232-0405	Sheet Metal, 0.090 2024-T3 (81348) QQ-A-250/5	SH
134	9535-00-232-0529	Sheet Metal, 0.063 2024-T3 (81348) QQ-A-250/5	SH
135	9535-00-232-0569	Sheet Metal, 0.050 2024-T3 (81348) QQ-A-250/5	SH
136	9535-00-232-7540	Sheet Metal, 0.063 7075-T6 (81348) QQ-A-250/13	SH
137	9535-00-236-7075	Sheet Metal, 0.125 7075-T6 (81348) QQ-A-250/13	SH
138	9535-00-249-5808	Sheet Metal, 0.040 7075-T6 (81348) QQ-A-250/13	SH
139	9535-00-249-5809	Sheet Metal, 0.050 7075-T6 (81348) QQ-A-250/13	SH
140	9515-00-596-1728	Sheet Metal, 0.040 Stainless (81349) MIL-S-5059	SH
141	9515-00-995-0731	Sheet Metal, 0.016 Stainless (81349) MIL-S-5059	SH
142	5305-00-854-6689	Sheet Metal Screws (96906) MS24617-33	BX
143	5305-00-883-0628	Sheet Metal Screws (96906) MS24617-21	BX
144	8040-00-828-7385	Silicon Sealant	TU
145	5940-01-079-1375	Splice, 14/16 AWG Blue (81349) MIL-T-7928/3	EA
146	5940-01-079-1646	Splice, 24/26 AWG Yellow (81349) MIL-T-7928/3	EA
147	5940-01-079-1647	Splice, 18/20 AWG Red (81349) MIL-T-7928/5	EA

APPENDIX C

Section II. EXPENDABLE SUPPLIES AND MATERIALS LIST (Cont)

ITEM NUMBER	NSN	DESCRIPTION	UNIT OF ISSUE
148	5940-01-079-1936	Splice, 12/10 AWG Yellow (81349) MIL-T-7928/3	EA
149	5940-00-500-8723	Splice, Conductor, Crimp Style, Wire Gage 10 (96906) MS25181-3	EA
150	6850-00-264-9038	Solvent, Cleaning, P-D-680 (81348)	GL
151	4020-00-753-6555	String (81349) MIL-T-43435	RO
152	7510-00-473-9855	Tape, Opaque Mat, Cotton (81349) MIL-T-23397	RO
153	7510-00-754-2522	Tape, Aluminum Adhesive (16059) P/N 14210	KT
154	5970-00-419-4291	Tape, Electrical (81349) MIL-I-24391	RO
155	7510-00-680-2450	Tape, Masking (80244) MIL-T-21595	RO
156	7510-00-074-5124	Tape, Green (58536) A-A-1586	RO
157	5940-00-143-4777	Terminal, Lug (81349) MIL-T-7928	BX
158	5940-00-115-0776	Terminal, Lug, 2 AWG 3/8 in. Hole (96906) MS20659-114	EA
159	5940-00-115-4992	Terminal, Lug, 6 AWG 3/8 in. Hole (96906) MS20659-110	EA
160	5940-00-143-4771	Terminal, Lug, 10 AWG 18/20 (96906) MS25036-103	EA
161	5940-00-143-4780	Terminal, Lug, Crimp Style Stud, Size 10, Wire Gage 16-14 (81349) MIL-T-7928	BX
162	5940-00-804-9184	Terminal, Quick Disconnect, Wire Size 14-16 (96906) MS27429-2	PG
163	5940-00-804-9185	Terminal, Quick Disconnect, Wire Size 18 (96906) MS27429-1	PG
164	1670-00-725-1437	Tiedown Strap, Cargo (240 in) (81349) MIL-T-27260, Type CGUB1	EA
165	5975-00-156-3253	Tiedown Strap, Elec (96906) MS3367-2-9	HD
166	5975-00-984-6582	Tiedown Strap, Elec (96906) MS3367-1-0	HD
167	8305-00-753-2967	Towel, Wiping (81348) CCCC46	BX
168	5310-00-275-4290	Washer Assortment (81349) MIL-W-1085	PG
169	5310-00-167-0765	Washer, Flat (88044) AN970-3	BX
170	5310-00-167-0766	Washer, Flat (88044) AN970-4	BX
171	5310-00-167-0801	Washer, Flat Steel, 3/16 (88044) AN960C10	EA

APPENDIX C

Section II. EXPENDABLE SUPPLIES AND MATERIALS LIST (Cont)

ITEM NUMBER	NSN	DESCRIPTION	UNIT OF ISSUE
172	5310-00-167-0812	Washer, Flat (88044) AN960C10L	EA
173	5310-00-205-8924	Washer, Flat (88044) AN960C416L	EA
174	5310-00-209-0027	Washer, Flat Steel, 1/4 (80205) NAS143-4	EA
175	5310-00-268-2735	Washer, Flat Assortment (81349) MIL-W-1085	HD
176	5310-00-883-3049	Washer, Flat Steel 5/16 (80205) NAS1587-5L	EA
177	6145-00-144-0231	Wire, Elec, 22 AWG (81349) MIL-W-81044/11	FT
178	6145-00-192-0680	Wire, Elec, 14 AWG (81349) MIL-W-81044/2	FT
179	6145-00-578-6595	Wire, Elec, 4 AWG (81349) MIL-W-5086/2	FT
180	6145-00-917-6378	Wire, Elec, 20 Gage (81349) MIL-W-22759/5	FT
181	6145-00-989-3723	Wire, Elec, 12 Gage (81349) MIL-W-22759/5	RO
182	6145-00-993-5490	Wire, Elec, 18 Gage (81349) MIL-W-22759/5	FT
183	6145-00-023-6777	Wire, Elec, 26 Gage (81349) MIL-W-16878/17	FT
184	6145-01-081-1073	Wire, Elec, 10 Gage (92607) M22759/5-10-9	FT
185	6145-01-122-3317	Wire, Elec, 2 Gage (81349) MIL-W-22759/3	FT
186	6145-01-203-5399	Wire, Elec, 16 Gage (81349) MIL-W-22759/3	FT

APPENDIX D

SUBSTITUTE MATERIALS/PARTS

BDAR FIXES SHALL BE USED ONLY IN COMBAT OR FOR TRAINING AT THE DISCRETION OF THE COMMANDER.
 (AUTHORIZED TRAINING FIXES ARE LISTED IN APPENDIX E.)
 IN EITHER CASE, DAMAGES SHALL BE REPAIRED BY STANDARD PROCEDURES AS SOON AS PRACTICABLE.

Section I. INTRODUCTION

D-1. GENERAL. This appendix lists substitute/alternate materials and parts. Section II contains prime National stock number (NSN) interchangeability cross-references for spare and repair parts from other models of helicopters.

Section III contains o-ring, packing, and gasket substitute information. Section IV contains petroleum, oil, lubricant (POL) substitute, and blending information. Section V contains a substitute table for structural metal alloys.

Section II. INTERCHANGEABLE PARTS

D-2. SCOPE. This section lists and cross-references UH-1H/V helicopter spare and repair parts to other systems having these same parts.

c. All subcomponents of the major components may be substituted; however, the level of disassembly must be consistent with field tools and skill levels available.

D-3. GENERAL.

a. Parts pertaining to the helicopter's mechanical and electrical functions are listed on Table D-1.

d. These table listings may be used to cross-reference parts and components provided from cannibalized aircraft.

b. All parts which have the same NSN can be used on the UH-1H and UH-1V without making any modification prior to installation.

Table D-1. Spare and Repair Parts

NOUN/NSN	U H 1 H	U H 1 V	E H 1 H	U H 1 M	H H 1 H	U H 1 E	U H 1 K	U H 1 L	U H 1 F	U H 1 P	U H 1 N	U H 6 0	A H 1 E	A H 1 S	A H 1 F	A H 1 P	A H 1 T	A H 6 4	C H 4 7	O H 5 8	O H 6 A	
BLADE MAIN ROTOR 1615-00-756-9140	X	X	X	X																		
HUB ASSEMBLY MAIN ROTOR 1615-00-886-1778	X	X	X	X																		
HUB ASSEMBLY MAIN ROTOR 1615-00-056-4550	X	X	X																			
TRANSMISSION ASSY 1615-00-919-1351	X	X	X																			
ENGINE 2840-00-134-4803	X	X	X																			
SKID TUBE 1620-00-795-0678	X	X	X																			
CROSS TUBE 1620-00-076-9036	X	X	X																			
CROSS TUBE 1620-00-967-7624	X	X	X																			
SHAFT T/R DR 1615-01-008-2798	X	X	X	X	X	X	X	X	X	X	X		X	X	X	X						
SHAFT T/R DR 1615-01-008-2797	X	X	X																			
BEARING, HANGER 1615-01-056-5365	X	X	X																			
ELEVATOR, LH 1560-00-996-3906	X	X	X																			
ELEVATOR, RH 1560-00-996-3905	X	X	X																			
SERVO CYLINDER, T/R 1650-00-014-2038	X	X	X																			
SERVO CYLINDER, F/C 1650-00-148-9077	X	X	X																			
TANK, HYD FLUID 1650-00-923-0629	X	X	X																			
TURBINE FAN, OIL COOL 2935-00-916-2528	X	X	X																			

Table D-1. Spare and Repair Parts (Cont)

NOUN/NSN	U H 1 H	U H 1 V	E H 1 H	U H 1 M	H H 1 H	U H 1 E	U : 1 K	U H 1 L	U H 1 F	U H 1 P	U H 1 N	U H 6 0	A H 1 E	A H 1 S	A H 1 F	A H 1 P	A H 1 T	A H 6 4	C H 4 7	O H 5 8	O H 6 A	
TURBINE FAN, OIL COOL 2935-00-066-0300	X	X	X	X																		
TURBINE FAN, OIL COOL 2935-00-939-8428	X	X	X																			
COOLER, LUBRICATING 2935-00-410-5884	X	X	X																			
PUMP, SUBM FUEL 2915-00-921-5660	X	X	X																			
PUMP, SUBM FUEL 2915-00-012-8684	X	X	X																			
MAST 1615-00-255-2896	X	X	X																			
BLADE, T/R 1615-00-472-7308	X	X	X																			
STARTER-GENERATOR 205-060-401-3	X	X	X																			
90° GEARBOX 1615-00-918-2677	X	X	X																			
42° GEARBOX 1615-00-918-2676	X	X	X	X																		
VALVE, HYDRAULIC 4810-01-022-3699	X	X	X																			
PUMP, HYDRAULIC 4320-00-134-0980	X	X	X																			
IGNITER-EXCITER 2925-00-064-9435	X	X	X	X	X	X	X	X	X	X	X		X	X	X	X	X		X			
LINEAR ACTUATOR 2995-00-990-3163	X	X	X	X	X	X	X	X					X	X	X	X						
TANK LUBE OIL 1560-00-070-7837	X	X	X																			
FILTER, XMSN OIL 1615-00-796-5004	X	X	X	X		X		X					X	X	X	X						
COOLER, XMSN OIL 1615-00-133-6226	X	X	X										X	X	X	X						

Table D-1. Spare and Repair Parts (Cont)

NOUN/NSN	U H 1 H	U H 1 V	E H 1 H	U H 1 M	H H 1 H	U H 1 E	U H 1 K	U H 1 L	U H 1 F	U H 1 P	U H 1 N	U H 6 0	A H 1 E	A H 1 S	A H 1 F	A H 1 P	A H 1 T	A H 6 4	C H 4 7	O H 5 8	O H 6 A	
MANIFOLD, FUEL 2915-00-003-5903	X	X	X										X	X	X	X						
VALVE, FUEL SHUTOFF 2915-00-991-3255	X	X	X																			
FILTER, FUEL 2915-00-003-5904	X	X	X	X	X	X	X						X	X	X	X						
FORCE GRADIENT 1560-00-888-7348	X	X	X	X	X	X			X	X			X	X	X	X						
CONNECTING LINK 3040-00-736-3999	X	X	X	X																		
CONNECTING LINK 3040-00-624-5142	X	X	X	X																		
CONNECTING LINK 3040-00-952-8835	X	X	X																			
CONNECTING LINK 3040-00-967-8758	X	X	X																			
CONNECTING LINK 3040-00-964-5066	X	X	X																			
CONNECTING LINK 3040-00-964-8758	X	X	X																			
CONNECTING LINK 3040-00-055-9023	X	X	X																			
CONNECTING LINK 3040-00-051-3647	X	X	X																			
CONNECTING LINK 3040-00-731-8098	X	X	X																			
CONNECTING LINK 3040-00-052-6312	X	X	X																			
CONNECTING LINK 3040-00-964-5073	X	X	X																			
CONNECTING LINK 3040-00-246-4554	X	X	X																			
CONNECTING LINK 3040-00-952-7145	X	X	X																			

Table D-1. Spare and Repair Parts (Cont)

NOUN/NSN	U H 1 H	U H 1 V	E H 1 H	U H 1 M	H H 1 H	U H 1 E	U H 1 K	U H 1 L	U H 1 F	U H 1 P	U H 1 N	U H 6 O	A H 1 E	A H 1 S	A H 1 F	A H 1 P	A H 1 T	A H 6 4	C H 4 7	O H 5 8	O H 6 A	
CONNECTING LINK 3040-00-051-3648	X	X	X																			
CONNECTING LINK 3040-00-877-2954	X	X	X																			
CONNECTING LINK 3040-00-964-5068	X	X	X																			
CONNECTING LINK 3040-00-775-7739	X	X	X																			
CONNECTING LINK 3040-00-624-6741	X	X	X	X																		
CONNECTING LINK 3040-00-624-5109	X	X	X	X																		
CONNECTING LINK 3040-00-964-5072	X	X	X																			
CONNECTING LINK 3040-00-624-5122	X	X	X	X																		
CONNECTING LINK 3040-00-624-5146	X	X	X	X																		
CONNECTING LINK 3040-00-624-6739	X	X	X	X																		
CONNECTING LINK 3040-00-624-5139	X	X	X	X																		
CONNECTING LINK 3040-00-624-5143	X	X	X	X																		
MAGNETIC BRAKE 1680-00-909-8098	X	X	X	X	X	X					X		X	X	X	X						X
MAGNETIC BRAKE 1680-00-921-5992	X	X	X	X																		
MAGNETIC BRAKE 1680-00-909-8716	X	X	X	X	X	X	X	X	X	X	X		X	X	X	X	X					X
GRADIENT, FORCE 1680-00-767-4219	X	X	X	X																		
GRADIENT, FORCE 1560-00-888-7348	X	X	X	X																		

Table D-1. Spare and Repair Parts (Cont)

NOUN/NSN	U H 1 H	U H 1 V	E H 1 H	U H 1 M	H H 1 H	U H 1 E	U H 1 K	U H 1 L	U H 1 F	U H 1 P	U H 1 N	U H 6 O	A H 1 E	A H 1 S	A H 1 F	A H 1 P	A H 1 T	A H 6 4	C H 4 7	O H 5 8	O H 6 A
TUBE, CYCLIC CONT RH 1560-00-624-5127	X	X	X	X																	
TUBE, CYCLIC CONT LH 1560-00-652-3262	X	X	X	X																	
IND, INDICATED SPEED 6610-00-526-4397	X	X	X	X																	
INDICATOR, ATTITUDE 6610-00-731-7969	X	X	X	X																	
ALTIMETER, ENCODER 6610-00-115-2405	X	X	X	X																	
ALTIMETER, ENCODER 6610-00-134-5625	X	X	X	X																	
ALTIMETER, ENCODER 6610-01-055-0468	X	X		X																	
INDICATOR, COURSE 5826-00-505-3094	X	X	X	X					X				X	X	X	X					X
INDICATOR, VERT VEL 6610-00-952-8832	X	X	X	X																	
INDICATOR, VERT VEL 6610-01-125-0726	X	X	X	X																	
INDICATOR, VERT VEL 6610-00-012-4624	X	X	X	X																	
INDICATOR, VERT VEL 6610-00-903-0714	X	X	X	X																	
INDICATOR, LIQ QTY 6680-00-181-1955	X	X	X																		
INDICATOR, LIQ QTY 6680-00-104-6704	X	X	X																		
INDICATOR, PRESS 6620-00-514-5334	X	X	X	X									X	X	X	X					
INDICATOR, OIL TEMP 6685-00-557-0370	X	X	X	X									X	X	X	X			X		
INDICATOR, OIL PRES 6620-00-179-1886	X	X	X	X			X														

Table D-1. Spare and Repair Parts (Cont)

NOUN/NSN	U H 1 H	U H 1 V	E H 1 H	U H 1 M	H H 1 H	U H 1 E	U H 1 K	U H 1 L	U H 1 F	U H 1 P	U H 1 N	U H 6 0	A H 1 E	A H 1 S	A H 1 F	A H 1 P	A H 1 T	A H 6 4	C H 4 7	O H 5 8	O H 6 A	
VOLTMETER, DC 6625-00-235-4782	X	X	X	X																		
VOLTMETER 6625-00-538-9683	X	X	X	X																		
METER, SPEC SCALE 6625-00-544-5899	X	X	X	X																		
ALTIMETER, PRESS 6610-00-110-3368	X	X	X	X									X	X	X	X			X	X		
INDICATOR RADIO-MAG 5826-00-897-4889	X	X	X	X																		
INDICATOR, IAS 6610-00-526-4397	X	X	X	X																		
INDICATOR, TACH 6680-00-907-8380	X	X	X	X																		
INDICATOR, TACH 6680-00-841-0302	X	X	X	X									X	X	X	X						
IND, TURN & SLIP 6610-00-169-1489	X	X	X	X							X		X	X	X	X						
IND, TURN & SLIP 6610-00-339-1254	X	X	X								X		X	X	X	X						
INDICATOR, TACH 5620-00-557-3023	X	X	X	X																		
INDICATOR, TEMP 6685-00-557-5910	X	X	X	X									X	X	X	X						
INDICATOR, ATTITUDE 6610-00-781-8537	X	X	X	X																		
INDICATOR, ATTITUDE 6610-00-179-9035	X	X	X	X																		
INDICATOR, ATTITUDE 6610-00-758-2385	X	X	X	X																		
INDICATOR, ATTITUDE 6610-00-905-0210	X	X	X	X																		
INDICATOR, ATTITUDE 6610-00-912-3613	X	X	X	X																		

Table D-1. Spare and Repair Parts (Cont)

NOUN/NSN	U H 1 H	U H 1 V	E H 1 H	U H 1 M	H H 1 H	U H 1 E	U H 1 K	U H 1 L	U H 1 F	U H 1 P	U H 1 N	U H 6 0	A H 1 E	A H 1 S	A H 1 F	A H 1 P	A H 1 T	A H 6 4	C H 4 7	O H 5 8	O H 6 A	
CLOCK 6645-00-084-1424	X	X	X	X							X		X	X	X	X			X	X		
BATTERY 6140-00-578-7525	X	X	X																			
BATTERY 6140-01-046-1116	X	X	X																			

Section III. O-RING, PACKINGS, AND GASKETS

D-4. SCOPE. This section lists and cross-references packings and o-rings in the military part number series to commercial or other military series, Table D-2.

D-5. GENERAL. Use of substitute or alternate packings may limit the operational life of the packing when exposed

to higher temperatures or fluids not in its range. The degradation process will not occur rapidly enough to affect the helicopter mission except in instances where low temperature packings or seals are used in high temperature applications on the engine or bleed air system.

Table D-2. Packings Reference and Temperature Guides Chart

PRIMARY PART NO. SERIES	MILITARY SPECIFICATION	PARKER COMPOUND	BASE POLYMER	TEMP GUIDE CONT SERV	DURO-METER	SERVICE
AN6227B AN67230B	MIL-P-5516 Class B	PS-01-30-5	NITRILE (BUNA N)	-65°F to +180°F	70	Air Force and Navy hydraulic fluid MIL-H-5606, MIL-H-83282
MS28775	MIL-P-25732	N304-7	NITRILE (BUNA N)	-65°F to +250°F	70	
MS29512 MS29513 2-, 3-	MIL-P-5315	N602-7	NITRILE (BUNA N)	-65°F to +180°F	60	Air Force & Navy aircraft fuel JP-4, JP-5
MS29561 NAS617	MIL-R-7362 Comp.A, Type 1	47-071	NITRILE (BUNA N)	-65°F to +250°F	70	Synthetic lubricants MIL-L-7808
AN6290 MS28778 2-, 3-	MIL-P-5510	N507-9	NITRILE (BUNA N)	-65°F to +180°F	90	Hydraulic oil, MIL-H-5606 MIL-H-83282
NAS1593 NAS1595	MIL-R-25897 CL 1	77-545	Fluoro-1 Elastomer	-20°F to +400°F	70	High temperature, fluid resistant.
NAS1594 NAS1596	MIL-R-25897 CL 2	V-377-9	Fluoro-1 Elastomer	-20°F to +400°F	90	High temperature, fluid resistant.

ALTERNATE, SUBSTITUTE PART NO.	COMMERCIAL DESIGNATION ASTMID735-58T	PARKER COMPOUND	BASE POLYMER	TEMP GUIDE CONT SERV	DURO-METER	SERVICE AND SPECIFICATIONS
2-, 3-	SC720BCE1 E3 F2	C147-7	NEOPRENE	-65°F to +300°F	70	Freon 12, weather & salt water resistant. AMS3209
2-, 3-	SC712BE1 E3 F2	C526-7	NEOPRENE	-65°F to +300°F	70	General purpose industrial Neoprene. AMS3209
2-, 3-	R810 B F2	F515-8	ETHYLENE PROPYLENE	-65°F to +300°F	80	Skydrol, Cellulube, & other phosphate esters, steam, water, air, dilute acids & alkalis.

Table D-2. Packings Reference and Temperature Guides Chart (Cont)

ALTERNATE, SUBSTITUTE PART NO.	COMMERCIAL DESIGNATION ASTMID735-58T	PARKER COMPOUND	BASE POLYMER	TEMP GUIDE CONT SERV	DURO- METER	SERVICE AND SPECIFICATIONS
2-, 3-	SB620B E1 E3 F1	N525-6	NITRILE (BUNA N)	-40°F to +250°F	60	Mineral oil & hydraulic fluid, water, steam, coolants, pneumatic service.
MS9021 MS9020 2-, 3-	SB712B E1 F2	N506-7	NITRILE (BUNA N)	-65°F to +225°F	65	Petroleum base fuel & low temperature resistance. AMS7271
2-, 3-	SB715B E1 E3 F2	N103-7	NITRILE (BUNA N)	-65°F to +225°F	70	Commercial gasoline, mineral oils & hydraulic fluids, pneumatic service.
2-, 3-	SB715B E1 E3 F1	N109-7	NITRILE (BUNA N)	-30°F to +250°F	70	Mineral oil & hydraulic fluids, alkalies, gasolines, diesel oils, pneumatics.
AN1239XX AN1240XX 2-, 3-	SB715B E1 E3 F2	N179-7	NITRILE (BUNA N)	-40°F to +250°F	70	Petroleum base fuel resistant. AMS7270
AN1238XX AN1239XX 2-, 3-	SB720B E1 F2	N180-7	NITRILE (BUNA N)	-20°F to +250°F	70	Petroleum base lubricating oil resistant. AMS7274
2-, 3-	SB715B E1 E3 F1	N214-7	NITRILE (BUNA N)	-40°F to +250°F	70	Listed by Underwriter Laboratories for fuels, oils, and gasolines.
2-, 3-	SB715B E1 E3 F1	N219-7	NITRILE (BUNA N)	-40°F to +250°F	70	Mineral oils & hydraulic fluids, gasolines, pneumatics, SAE 120R Class 1, UL Listed.

Table D-2. Packings Reference and Temperature Guides Chart (Cont)

ALTERNATE, SUBSTITUTE PART NO.	COMMERCIAL DESIGNATION ASTMID735-58T	PARKER COMPOUND	BASE POLYMER	TEMP GUIDE CONT SERV	DURO- METER	SERVICE AND SPECIFICATIONS
2-, 3-	SB710B E1 E3 F1	N398-7	NITRILE (BUNA N)	-40°F to +250°F	70	Water service. Low swell, extremely stable. Oil resistance.
2-, 3-	SB820B E1 E3 F1	N256-8	NITRILE (BUNA N)	-20°F to +225°F	80	For rotary seals. Do not use with stainless steel.
2-, 3-	SB715B E1 E3 F1	N532-8	NITRILE (BUNA N)	-20°F to +250°F	80	Mineral oils & hydraulic fluids, gasoline, pneumatics.
2-, 3-	SB915B E1 E3	N183-9	NITRILE (BUNA N)	-30°F to +250°F	90	Mineral oil & hydraulics fluid, pneumatics. High extrusion resistance.
2-, 3-	SB915B E1 E3	N552-9	NITRILE (BUNA N)	-30°F to +250°F	90	Mineral oil & hydraulic fluids pneumatics.
2-, 3-	TA-605B E1 E3 F2	S418-6	SILICONE	-80°F to +450°F	60	Air & gases. Static seal only. AMS3303
2-, 3-	TA705B E1 E3 LF2	S417-7	SILICONE	-80°F to +450°F	70	Air & gases. Static seal only.
MS9068 2-, 3-	TA-705BE1 E3 F2	S604-7	SILICONE	-80°F to +450°F	70	Air & gases. Static seal only. AMS3304
2-, 3-	None	77-545	Fluoro-1 Elastomer	-20°F to +400°F	70	High temperature oils, aromatic solvents, chemical service. AMS7278
2-, 3-	None	V377-9	Fluoro-1 Elastomer	-20°F to +400°F	90	High temperature oils, aromatic solvents, chemical service. AMS7278

Section IV. PETROLEUM, OIL, AND LUBRICANTS (POL)

D-6. SCOPE. This section lists various types of substitute fuels, lubricants, and hydraulic fluids which can be used on the UH-1H/V helicopter. Contained in this section is general information concerning types, uses, and effects of such POL substitutes and methods of purging and flushing systems after use.

D-7. GENERAL.

a. Some products are made up of chemical ingredients which are not compatible with products used on a UH-1H/V aircraft. Some fuels, oils, and hydraulic fluids can have an adverse effect on systems and components compatible with the UH-1H/V systems; therefore, it is advisable to properly identify the product by specification number and name for cross-reference with primary and expedient products available.

b. National stock numbers are used in conjunction with specification numbers to distinguish them from foreign products. The identification of (NATO) product numbers relate directly to U.S. Military Specification Numbers and thus are considered direct replacements.

c. In some situations, POL substitute products of friendly or enemy nations can be used; however, CAUTION should be exercised due to the possibility of sabotage. If there is no other alternative but to use enemy products, check for signs of contamination, discoloration, smell, and thickness.

d. Once a product under consideration is identified, as described above, it will fall in one of three categories. These categories are defined as follows:

(1) Primary Products. These are basic products for which the system was designed. The system will function without limitation.

(2) Alternate Product. These are products that closely match the primary product and may result in some reduced performance with no effect on system durability. There are no limitations on duration of use.

CAUTION

The helicopter shall not be flown when emergency fuel has been used for a total cumulative time of 50 hours unless a hot section inspection is performed.

(3) Emergency/Expedient Products. These are products that can be used for only short periods of time. These products are to be used as a last resort. These products will cause poor performance and system damage after prolonged use.

e. Table D-3 lists some possible U.S. military and commercial fuels, in proper priority, that may be used. Table D-4 lists primary and alternate fuel sources for various countries. Table D-5 lists some commercial fuel sources that may be substituted for the primary or standard JP-4 fuel and also some alternate fuel sources which are similar to JP-5 and JP-8.

f. Some substitute fuels, which alone cannot be used on UH-1H/V, can be blended with a primary fuel and can then be utilized for engine operation.

(1) When using fuel blends, it is preferable to premix the fuels in a container before pouring into tank. This method of mixing the primary fuel with a substitute fuel ensures that the fuels mix completely. The best expedient fueling method is to add both fuels at the same time from two separate fuel lines.

Table D-3. Substitute U.S. Fuels

PRIMARY FUEL	ALTERNATE FUEL	EMERGENCY FUEL	MILITARY SPECIFICATION	COMMERCIAL SPECIFICATION
Aviation Turbine Fuel (JP-4)			MIL-T-5624 (JP-4) NATO CODE F-40	ASTM-D-1655-70 (Jet B JP-4 Type)
	Aviation Turbine Fuel (JP-5)		MIL-T-5624 (JP-5) NATO CODE F-44	ASTM-D-1655-70 (Jet A JP-5 Type)
	Aviation Turbine Fuel (JP-8)		MIL-T-83133 (JP-8) NATO-CODE F-34	ASTM-D-1655-70 (Jet A-1 JP-8 Type)
		AVGAS (any)	MIL-G-5572 NATO CODES F-12, F-18, F-22	

Table D-4. Approved Alternate Foreign Commercial
Fuels for the UH-1H/V Helicopter

	PRIMARY FUEL	ALTERNATE FUELS	
U. S. MILITARY FUEL	JP-4(MIL-T-5624)	JP-5(MIL-T-5624)	JP-8-(MIL-T-83133)
NATO CODE NO.	F-40	F-44	F-34
PRODUCT DESCRIPTION	TURBINE FUEL, AVIATION TYPE: WIDE CUT TYPE	TURBINE FUEL, AVIATION: HIGH FLASH KEROSENE TYPE	TURBINE FUEL, AVIATION: KEROSENE TYPE
BELGIUM	BA-PF-2B	BA-PF-6	
CANADA	3-GP-22F	3-6P-24.e	
DENMARK	MIL-T-5624 Grade JP-4		
FRANCE	AIR 3407/A		
FEDERAL REPUBLIC OF GERMANY	TL 9130-006	UTL 9130-007/ UTL 9130-010	
GREECE	MIL-T-5624 Grade JP-4		
ITALY	AA-M-C-1421	AMC-143	
NETHERLANDS	MIL-T-5624 Grade JP-4	D. Eng. RD. 2493	
NORWAY	MIL-T-5624 Grade JP-4		
PORTUGAL	MIL-T-5624 Grade JP-4		
TURKEY	MIL-T-5624 Grade JP-4		
UNITED KINGDOM	D. Eng. RD. 2454	D. Eng. RD. 2498	
UNITED STATES	MIL-T-5624 Grade JP-4	MIL-T-5624 Grade JP-5	
USSR	GOST 1842-52 GOST 10227-62 T-1. TS-1		

Table D-5. Commercial Fuels for the UH-1H/V Helicopter

SOURCE	PRIMARY OR STANDARD FUEL	ALTERNATE FUELS	
U.S. MILITARY FUEL	JP-4(MIL-T-5624)	JP-5(MIL-T-2624)	JP-8(MIL-T-83133)
NATO CODE NO.	F-40	F-44	F-34
COMMERCIAL FUEL (ASTM-D-1655)	JET B	JET A	JET A-1
American Oil Co.	American JP-4	American Type A	
Atlantic Richfield Richfield Div	Arcojet B	Arcojet A Richfield A	Arcojet A-1 Richfield A-1
B. P. Trading	B. P. A. T. G		B. P. A. T. K.
Caltex Petroleum Corp.	Caltex Jet B		Caltex Jet A-1
City Service Co.		CITCO A	
Continental Oil Co.	Conoco JP-4	Conoco Jet-50	Conoco Jet-60
Exxon Co. U. S. A.	Exxon Turbo Fuel B	Exxon A	Exxon A-1
Gulf Oil	Gulf Jet B	Gulf Jet A	Gulf Jet A-1
Mobil Oil	Mobil Jet B	Mobil Jet A	Mobil Jet A-1
Phillips Petroleum	Philjet JP-4	Philjet A-50	
Shell Oil	Aeroshell JP-4	Aeroshell 640	Aeroshell 650
Sinclair		Superjet A	Superjet A-1
Standard Oil Co.		Jet A Kerosene	Jet A-1 Kerosene
Chevron	Chevron B	Chevron A-50	Chevron A-1
Texaco	Texaco Avjet B	Avjet A	Avjet A-1
Union Oil	Union JP-4	76 Turbine Fuel	

NOTE:

Anti-icing and Biocidal Additive for Commercial Turbine Engine Fuel. The additive provides anti-icing protection and functions as a biocide to kill microbial growths in aircraft fuel systems. Icing inhibitor conforming to MIL-I-27686 shall be added to commercial fuel, not containing an icing inhibitor, during refueling operations, even though the engine or aircraft has a fuel heater and regardless of ambient temperatures. Refueling operations shall be accomplished in accordance with accepted commercial procedures. This additive (Prist or eq.) is not available through the Army Supply System, but is to be locally procured when needed.

(2) There is no special limitation on the use of Army standard fuel or alternate fuel. When using an emergency fuel, a fuel mixture which contains over 10 percent leaded gasoline is considered to be all leaded fuel. When using an emergency fuel, an entry on the faults and remarks column of DA Form 2408-13, Inspection Record, should be made. The entry should annotate the type of fuel, additives, and duration of operation.

(3) Fuels having the same NATO code number are interchangeable, and fuels conforming to ASTM-D-1655 specification may be used when standard fuel MIL-T-5624-JP4 is not available. Refer to Table D-3.

g. This section lists primary, alternate, and expedient lubricants and hydraulic fluids. The lubricants and hydraulic fluids used in UH-1H/V systems and components must have a compatible base composition, as well as good additive level. Being that the purpose of lubricants and hydraulic fluids is to reduce wear, support bearing loads, and provide cooling, their chemical composition must be compatible. In addition to lubricating, hydraulic fluids must transmit power and motion. If two incompatible hydraulic fluids are mixed, there is a tendency of a gel substance forming within the system and ruining it.

(1) Some lubricants will not withstand UH-1H/V temperatures or loads for extended periods of time. These types of lubricants do not contain the necessary base properties for withstanding long term performance; therefore, they are recommended only as a last resort.

(2) Expedient lubricants can cause one of three problems.

(a) They may not allow proper efficient operations because of improper viscosity.

(b) They may allow an increase in wear because of improper viscosity.

(c) They may cause seals to swell or create deposits because of improper composition.

h. Table D-6 lists the primary lubricants and hydraulic fluids which are used as primary, alternate, or emergency uses on the UH-1H/V helicopter.

CAUTION

Lubricating oil MIL-L-23699 shall not be used in ambient temperatures below $-25^{\circ}\text{F}/-32^{\circ}\text{C}$.

NOTE

It is not advisable to mix MIL-L-7808 and MIL-L-23699 oils, except during an emergency. **If** oils are mixed, the system should be flushed within six hours. An entry on DA Form 2408-13 is required when the oils are mixed. Hydraulic oils MIL-L-83282 and MIL-L-5606 should not be mixed except during an emergency. When these oils are mixed with each **other or any other oil, a DA Form 2408-13 is required.**

Table D-6. Substitute Lubricants and Hydraulic Fluids

UH-1H/V EQUIPMENT	PRIMARY		ALTERNATE
	MIL-SPEC	NATO CODE	
Engine Transmission 42° Gearbox 90° Gearbox Pillow Block	MIL-L-23699 (use in ambient temp above -25°F/-32°C)	0-156	0-149 <u>CAUTION</u> NATO 0-149 is NOT com- patible with MIL-23699. DO NOT MIX . Drain flush and fill when conversion required.
	NOTE Do not use MIL-L-23699 below -25°F (-32°C)		
	MIL-L-7808 (use in ambient temp above -25°F/-32°C)	0-148	0-149 **Mixture of MIL-L-23699 and MIL-L-7808 is accept- able in an emergency.
Main Rotor Hub P/N 204-012-101-31 (typ UH-1H/V)	MIL-L-2104, Grade 40 (use in ambient temp 41°F/5°C and above)	0-230	Mix oils only in an emergency.
	MIL-L-2104, Grade 30 MIL-L-46152, Grade 30 (use in ambient temp 0°F/-18°C to 41°F/5°C)	0-230	Make DA Form 2408-13 entry when mixing occurs. MUST be flushed withi n 6-hours.
	MIL-L-2104, Grade 10 MIL-L-46152, Grade 10W30 (use in ambient temp -20°F/-29°C to 0°F/-18°C)	0-230	
	MIL-L-46167, DEXTON II ATF (use in ambient temp -65°F/-54°C to -4°F/-20°C)		

Table D-6. Substitute Lubricants and Hydraulic Fluids (Cont)

UH-1H/V EQUIPMENT	PRIMARY		ALTERNATE
	MIL-SPEC	NATO CODE	
Hydraulic System	MIL-H-5606 (use in ambient temp below -30°F/-35°C)	H-515	Mix hydraulic fluid only in an emergency.
	MIL-H-83282 (use in ambient temp above -30°F/-35°C)		Make DA Form 2408-13 entry when mixing occurs.

Table D-7. Substitute Commercial Oils and Hydraulic Fluids

For MIL-L-7808 - Lubricating Oil, Acft Turbine Engine, Synthetic Base Substitute:

PQ Turbine Oil 8365	American Oil & Supply Co.
Exxon Turbo Oil 2389	Exxon Co. USA
Esso Turbo Oil 2389	
RM-184A	
RM-201A	Mobil Oil Corp.
E-6825	Stauffer Chemical Co.
Royco 807HR	Royal Lubricants Co.
Royco 808HR	
PL-10568	Rohm & Haas Co.

For MIL-L-23699 - Lubricating Oil, Acft Turbine Engines, Synthetic Base Substitute:

PQ Turbine Lubricant 6423	American Oil & Supply Co.
PQ Turbine Lubricant 5247	
PQ Turbine Lubricant 6700	
PQ Turbine Lubricant 7731	
PQ Turbine Lubricant 8878	
PQ Turbine Lubricant 9595	
PQ Turbine Lubricant 9596	
PQ Turbine Lubricant 9597	
Brayco 899	Bray Oil Co.
Brayco 899-G	
Brayco 899-S	
Brayco 899-D	
Castrol 205	Castrol Oil Inc.
Chevron Jet Engine Oil 5	Chevron International Oil Co., Inc.
STO-21919	Drew Chemical Corp.
STO-21919A	
STO-6530	

Table D-7. Substitute Commercial Oils and Hydraulic Fluids (Cont)

HATCOL 3211	W. R. Grace & Co., Hatco Chemical Div.
HATCOL 3611	
Esso Turbo Oil 2380	Humble Oil & Refining Co.
Esso Turbo Oil 2380	
2395 Turbo Oil (WS-6459)	
2392 Turbo Oil	
2393 Turbo Oil	
Gulflight 20	Gulf Oil Co.
Mobil Jet II/RM-139A	Mobil Oil Corp.
Avrex S Turbo 260	
Avrex S Turbo 265	
ROYCO 899 (C-915)	Royal Lubricants Co.
Stauffer Jet II	
Royco 899SC	
Aeroshell Turbine Oil 500	Shell Oil Co.
Shell Aircraft Turbine 551	
AeroShell Turbine Oil 550	Shell International Petroleum Co. Ltd.
Chevron Jet Engine Oil 5	Standard Oil Co. of California
Stauffer Jet II	Stauffer Chemical Co.
Stauffer 6924	
SATO 7377	Texaco, Inc.
SATO 7730	
Starjet 5	

For MIL-H-5606 - Hydraulic Fluid, Petroleum Base, Acft and Ordnance Substitute:

"P0" Hydraulic Fluid 4226	American Oil & Supply Co.
Brayco 757B	Bray Oil Co.
Brayco 756C	
Brayco 756D	
Brayco 756E	
Castrol Hyspin A	Castrol Oils, Inc.
Univis J41	Humble Oil & Refining Co.
Univis J41	Exxon Co.
Mobil Aero HFB	Mobil Oil Corp.
Petrofluid 5606B	Pennsylvania Refining Co.
Petrofluid 4607	
ROYCO 756C	Royal Lubricants Co.
ROYCO 756D	
DS-437	
PED 3565	Standard Oil Co. of California
PED 3337	
TL-5874	
Stauffer Aero Hydaroil 500	Texaco, Inc. Stauffer Chemical Co.
25606	MZF Associates
FP-221	Union Carbide Corp.

Table D-7. Substitute Commercial Oils and Hydraulic Fluids (Cont)

For MIL-H-83282:

The following commercial oils may be purchased locally under the following manufacturer's designation:

Brayco Mi cornic 882
XRM-230A
XRM-231A
ROYCO 782
Hanover R-2
HF-832

Brayco Oil Co.
Mobil 011 Corp.
Mobil 011 Crop.
Royal Lubricants Co.
Hanover Chemical Industries, Inc.
Hanover Processing Co.

Section V. STRUCTURAL METAL ALLOYS

D-8. **SCOPE.** This section lists and cross-references substitute structural metal alloys.

D-9. **GENERAL.** Due to the short term of use, weight and dissimilar metal corrosion, considerations can be overlooked during BDAR structural repairs. Metal selection should be based only on strength requirements. Refer to Table D-8 and use the following steps to locate substitute metal alloy types:

a. Locate the material to be replaced on the line in the left-hand column.

b. Locate the substitute material in the vertical columns.

c. To obtain the minimum thickness of the substitute material, multiply the thickness of the material to be replaced by the factor shown at the intersection of the line and column found in step a & b, substitute standard gage equal to this thickness or nearest standard gage.

Table D-8. Metal Substitution Chart

MATERIAL TO BE REPLACED	ULTIMATE TENSILE STRENGTH PSI	2024			1025	7075 T6		4130 8630 STEEL		TITANIUM				STAINLESS STEEL		
		T3&4 CLAD	T4 EXTRUDED	T6 BARE	STEEL	CLAD	EXTRUDED	90 KSI	125 KSI	99%	8 Mn	6AL-4V	6AL-6V-2Sn	1/4 301	1/2 302	321 347
6061-T6 EXTRUDED	38,000	1.0	1.0	1.0	1.0	1.0	1.0	1.0	1.0	1.0	1.0	1.0	1.0	1.0	1.0	1.0
AZ31A-II MAGNESIUM	39,000	1.0	1.0	1.0	1.0	1.0	1.0	1.0	1.0	1.0	1.0	1.0	1.0	1.0	1.0	1.0
6061-T6 CLAD	42,000	1.0	1.0	1.0	1.0	1.0	1.0	1.0	1.0	1.0	1.0	1.0	1.0	1.0	1.0	1.0
2024 T4 EXTRUDED	57,000	1.0	1.0	1.0	1.04	1.0	1.0	1.0	1.0	1.0	1.0	1.0	1.0	1.0	1.0	1.0
2024 T4 CLAD	58,000	1.0	1.02	1.0	1.05	1.0	1.0	1.0	1.0	1.0	1.0	1.0	1.0	1.0	1.0	1.0
2024 T3 CLAD	60,000	1.04	1.05	1.0	1.09	1.0	1.0	1.0	1.0	1.0	1.0	1.0	1.0	1.0	1.0	1.0
2024 T6 BARE	62,000	1.07	1.09	1.0	1.13	1.0	1.0	1.0	1.0	1.0	1.0	1.0	1.0	1.0	1.0	1.0
2024 T81 CLAD	64,000	1.1	1.12	1.03	1.16	1.0	1.0	1.0	1.0	1.0	1.0	1.0	1.0	1.0	1.0	1.0
2024 T88 CLAD	70,000	1.21	1.23	1.13	1.25	1.0	1.0	1.0	1.0	1.0	1.0	1.0	1.0	1.0	1.0	1.0
7075 T6 CLAD	72,000	1.24	1.27	1.16	1.31	1.0	1.0	1.0	1.0	1.0	1.0	1.0	1.0	1.0	1.0	1.0
7075 T6 BARE	78,000	1.35	1.37	1.26	1.42	1.09	1.0	1.0	1.0	1.0	1.0	1.0	1.0	1.0	1.0	1.0
7075 T6 EXTRUDED	78,000	1.35	1.37	1.26	1.42	1.09	1.0	1.0	1.0	1.0	1.0	1.0	1.0	1.0	1.0	1.0
7178 T6 BARE	84,000	1.45	1.48	1.36	1.53	1.17	1.08	1.0	1.0	1.0	1.0	1.0	1.0	1.0	1.0	1.0
7178 T6 EXTRUDED	84,000	1.45	1.48	1.36	1.53	1.17	1.08	1.0	1.0	1.0	1.0	1.0	1.0	1.0	1.0	1.0
TITANIUM 99Z	80,000	1.38	1.40	1.29	1.45	1.11	1.02	1.0	1.0	1.0	1.0	1.0	1.0	1.0	1.0	1.0
TYPE 321 & 347 CRES	100,000	1.72	1.75	1.61	1.82	1.38	1.28	1.11	1.0	1.25	1.0	1.0	1.0	1.0	1.0	1.0
TITANIUM 8Mn	120,000	2.06	2.1	1.93	2.18	1.66	1.53	1.33	1.0	1.50	1.0	1.0	1.0	1.0	1.0	1.20
TYPE 301 STAINLESS	125,000	2.15	2.19	2.09	2.27	1.73	1.60	1.38	1.0	1.56	1.04	1.0	1.0	1.0	1.0	1.25
TITANIUM 6AL-4V	134,000	2.31	2.35	2.16	2.43	1.86	1.71	1.48	1.07	1.67	1.12	1.0	1.0	1.07	1.0	1.34
TITANIUM 4AL-4Mn	140,000	2.41	2.45	2.25	2.55	1.94	1.79	1.55	1.12	1.75	1.16	1.04	1.00	1.12	1.0	1.40
TYPE 301 STAINLESS	150,000	2.58	2.63	2.42	2.73	2.08	1.92	1.66	1.20	1.88	1.25	1.11	1.0	1.2	1.0	1.50
TITANIUM 6AL-6V-2Sn	155,000	2.67	2.71	2.5	2.81	2.15	1.98	1.72	1.24	1.93	1.29	1.15	1.0	1.24	1.03	1.55

APPENDIX E

BDAR FIXES AUTHORIZED FOR TRAINING

**BDAR FIXES SHALL BE USED ONLY IN COMBAT OR FOR TRAINING
AT THE DISCRETION OF THE COMMANDER.
(AUTHORIZED TRAINING FIXES ARE LISTED IN APPENDIX E.)
IN EITHER CASE, DAMAGES SHALL BE REPAIRED BY STANDARD
PROCEDURES AS SOON AS PRACTICABLE.**

NOTE

The repair procedures listed below are authorized for sustainment training. They do not permanently alter aircraft or components. These procedures duplicate those highlighted in each system's chapter, Repair Procedure Index, surrounded by a box.

All other BDAR fixes contained in this manual can be used to train soldiers if scrap parts or beyond economical repair (BER) components are available for practice repair. Such training must be approved by the unit commander. Most of the other procedures not listed in this appendix will permanently alter or damage the equipment.

REPAIR PROCEDURE

PARA NO.

DRIVE TRAIN

Transmission Oil Pressure Switch Leak	8-6
Transmission Oil Pressure Transmitter Leak	8-7
External Oil Filter Leak	8-8

HYDRAULIC AND PNEUMATIC

Hydraulic Filter Damage and Leaking	9-7
Relief Valve Leaking Hydraulic Fluid	9-9
Solenoid Valve, Damaged and Leaking	9-11
Pressure Switch Damaged and Leaking	9-13
Check Valve, Leaking	9-15
Armament Hydraulic System Leaking	9-17
Metal Tube Leaking/Damaged	9-20
Bleed Air Line Leaking	9-22
Bleed Air Line Leaking	9-23
Bleed Air Fitting Damaged	9-24

INSTRUMENTS

Instrument Replacement	10-6
----------------------------------	------

BDAR FIXES AUTHORIZED FOR TRAINING (Cont)

<u>REPAIR PROCEDURE</u>	<u>PARA NO.</u>
ELECTRICAL AND AVIONICS SYSTEM	
Unshielded Wire, Damaged	11-5
Wire Repair Segments, Unshielded Wires	11-6
Damaged Wire Insulation	11-7
Shielded Cable Repairs	11-8
Shielded Cable Repair Segments	11-9
Shield Terminators	11-10
Terminator for Nickel-Plated Shields	11-11
Coax Cable	11-14
Component Bridging (Bypassing)	11-18
Damaged Fuse Emergency Fabrication	11-20
Broken Fuses.	11-21
Substitute Antenna	11-26
FUEL SYSTEM	
Fuel Cell Isolation.	12-8
Fuel Filter Assembly, Damaged and Leaking.	12-10

APPENDIX F
AVIONICS CONFIGURATIONS

**BDAR FIXES SHALL BE USED ONLY IN COMBAT OR FOR TRAINING
AT THE DISCRETION OF THE COMMANDER.
(AUTHORIZED TRAINING FIXES ARE LISTED IN APPENDIX E.)
IN EITHER CASE, DAMAGES SHALL BE REPAIRED BY STANDARD
PROCEDURES AS SOON AS PRACTICABLE.**

Section I. INTRODUCTION

F-1. SCOPE. This appendix lists and depicts the major components, cable routes, and wiring terminations pertaining to the UH-1H/V helicopter. This information is furnished as an aid to expedient repair techniques described in Chapters 10 and 11.

F-2. GENERAL. The actual configurations may vary depending on particular requirements or changes incorporated through modification work order (MWO) action and special purpose alterations.

Figures F-1 thru F-16 show typical location of radios and their associated components in relation to the helicopter and lists the radio and component part number. Each figure also has a table associated with the avionics system which contains a complete wire listing. This includes the wire number, type (shielded, not shielded, or pair twisted with shield), both end plugs, and the pin numbers on each end plug.

<u>DRAWING DESIGNATION</u>	<u>PART NUMBER</u>	<u>DESCRIPTION</u>
1	AT-1108/ARC	Antenna
2	C-62987/ARC-51BX	Control, AN/ARC-51BX
3	MT-2653/ARC	Mount, AN/ARC-51BX
4	RT-742()/ARC	Receiver-Transmitter, AN/ARC-51BX

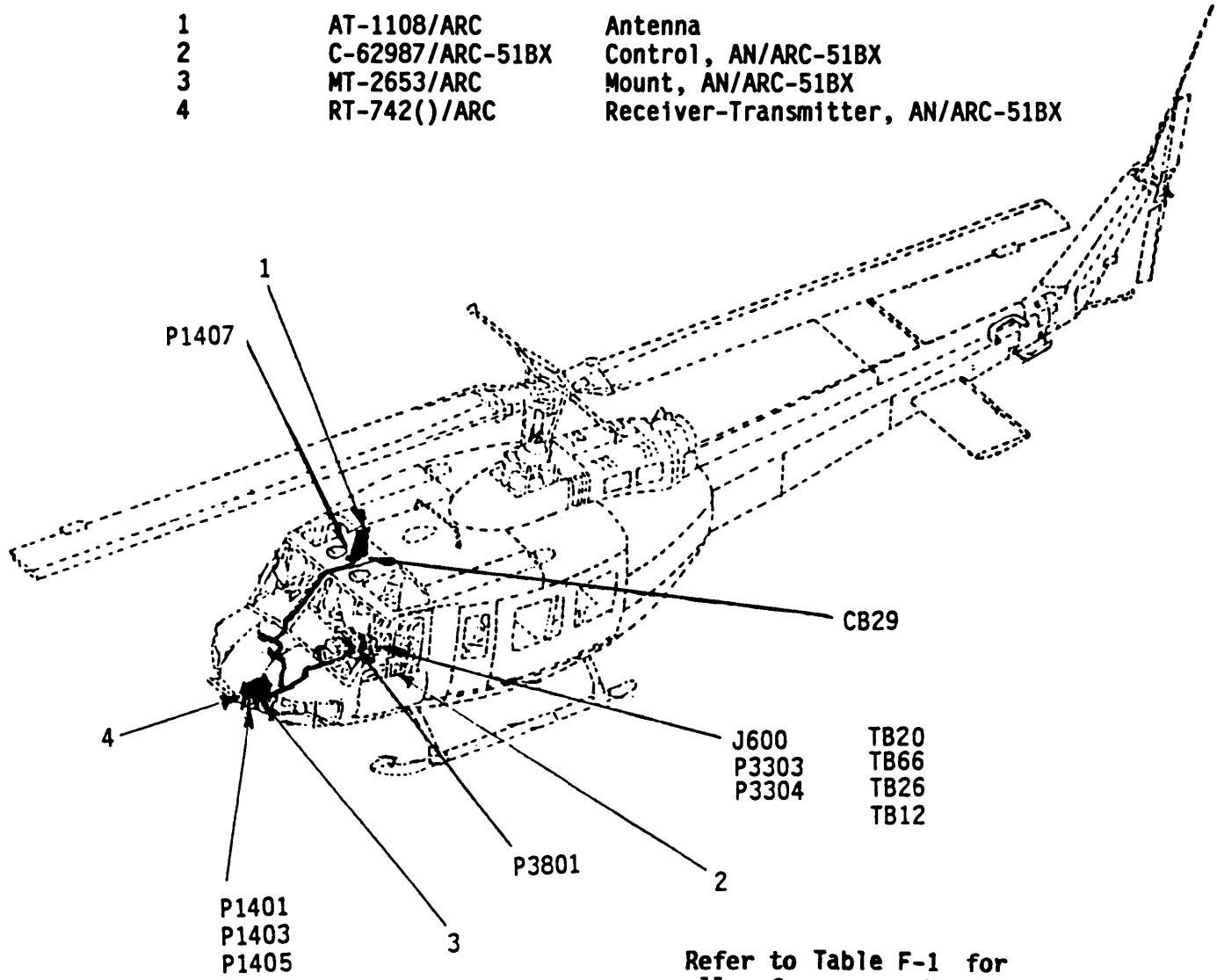

Figure F-1. UHF/AM Radio System AN/ARC-51BX

Table F-1. UHF/AM Radio System AN/ARC-51BX

WIRE NUMBER	TYPE 2	END 1	PIN 1	END 2	PIN 1
RU1264A22	NO/S	P1401	E	P3801	J
RU1231A22	NO/S	P1401	u	P3801	v
RU1232A22	NO/S	P1401	T	P3801	w
RU1233A22	NO/S	P1401	L	P3801	<u>a</u>
RU1234A22	NO/S	P1401	M	P3801	<u>b</u>
RU1235A22	NO/S	P1401	K	P3801	z
RU1236A22	NO/S	P1401	N	P3801	a
RU1237A22	NO/S	P1401	J	P3801	T
RU1238A22	NO/S	P1401	Y	P3801	<u>f</u>
RU1239A22	NO/S	P1401	F	P3801	g
RU1240A22	NO/S	P1401	z	P3801	h
RU1241A22	NO/S	P1401	H	P3801	1
RU1242A22	NO/S	P1401	g	P3801	Y
RU1243A22	NO/S	P1401	P	P3801	K
RU1244A22	NO/S	P1401	x	P3801	M
RU1245A22	NO/S	P1401	g	P3801	x
RU1246A22	NO/S	P1401	b	P3801	z
RU1247A22	NO/S	P1401	5	P3801	s
RU1248A22	NO/S	P1401	R	P3801	R
RU1230A22	NO/S	P1401	v	P3801	v
RU1249A22	NO/S	P1403	c	P3801	D
RU1257A22	NO/S	P1403	z	P3801	B
RU1251A22	NO/S	P1403	T	P3801	A
RU1252A22	SHI ELD	P1403	R	P3801	E
RU1272A22	NO/S	P1403	<u>a</u>	P3801	H
RU1250A22	NO/S	P1403	<u>P</u>	P3304	F
RU1274A22	NO/S	P1403	u	TB26	3
RU1267A22	NO/S	P1403	A	CB29(UHF)	-
RU1267B22	NO/S	P1403	B	CB29(UHF)	-
RU1266A18N	NO/S	P1403	Y	TB66	i
RU1266B18N	NO/S	P1403	x	TB66	9
RU1266C22	NO/S	P1403	D	(SHI ELD GND)	Pi ns V* and E*
RU1258A22	PR/S	P1403	v* (Red)	P3303	A
RU1259A22	PR/S	P1403	E* (Bl k)	P3303	u
RU1256A22	SHI ELD	P3801	F	J600	24
RU1273A	COAX	P1405	-	P1407	(AT 1108)]
RU1254A18N	NO/S	P3801	N	TB26	6
L122A20	NO/S	P3801	P	TB12	1

1 Underlined Connector Pin Letters Denote Lower Case

2 Denotes: NO/S--No Shi el d
PR/S--Pai rTwi sted, W/Shi el d

<u>DRAWING DESIGNATION</u>	<u>PART NUMBER</u>	<u>DESCRIPTION</u>
1	AT-1108/ARC	Antenna, VHF/UHF
2	AN/ARC-115()	Radio, VHF/AM
3	205-075-382	Filter, Band Pass, VHF

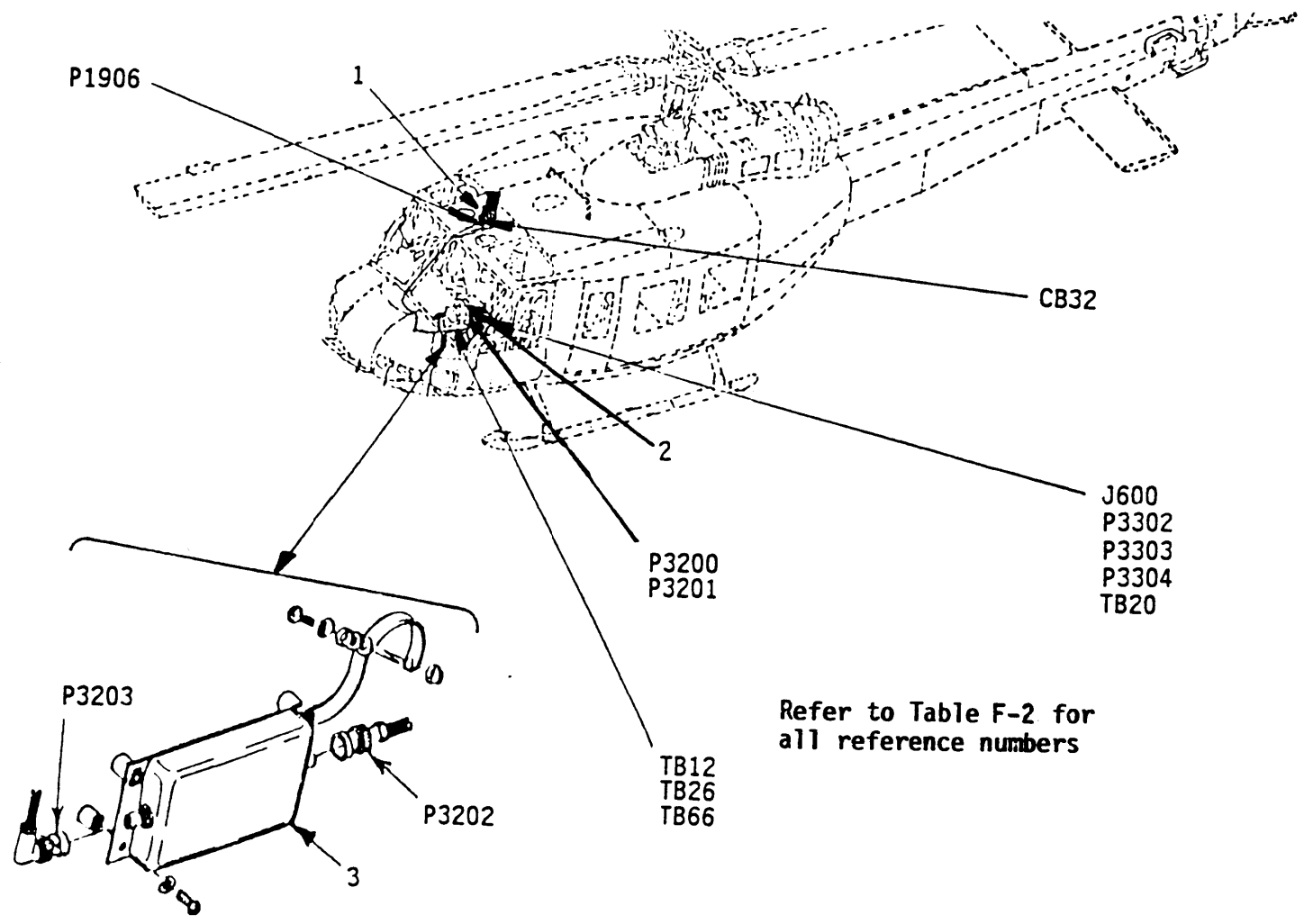

Refer to Table F-2 for all reference numbers

Figure F-2. VHF/AM Radio AN/ARC-115

Table F-2. VHF / AM Radio AN/ARC '115

WIRE NUMBER	TYPE 2	END 1	PIN 1	END 2	PIN 1
ARC115-101A	COAX	P3200	-	P3202 (FL6)	-
ARC115-102A	COAX	P3203 (FL6)	-	P1906 (AT-1108)	-
ARC115-27A22	SHI ELD	P3201	<u>B</u>	J600	<u>e</u>
ARC115-28A22N	SHI ELD	P3201	<u>h</u>	TB66	<u>7</u>
ARC115-2A22	NO/S	P3201	<u>P</u>	P3201	V
ARC115-31A22	NO/S	P3201	<u>n</u>	P3304	G
ARC115-14A20N	NO/S	P3201	<u>P</u>	TB26	4
ARC115-5A20N	NO/S	P3201	E	TB26	4
ARC115-4A20	NO/S	P3201	D	CB32(VHF)	
ARC115-3A22	NO/S	P3201	c	SPLICE	
ARC115-3B22	NO/S	SPLICE		TB12	3
ARC115-3A22	NO/S	SPLICE		P3302	c
ARC115-11A22 (BLK]	PR/S	P3201	L	P3303	Z
ARC115-10A22 (RED]	PR/S	P3201	K	P3303	G
ARC115-60A22N	NO/S	P3201	SHI ELD ON L & K	TB66	7
ARC115-11B22N	SHI ELD	P3303	w	TB66	7
ARC115-10B22	SHI ELD	P3303	c	TB20	5
ARC115-61B22	NO/S	P3303	D	SHI ELD ON W & C	

1 Underlined Connector Pin Letters Denote Lower Case

2 Denotes: NO/--No Shield
PR/S--Pair Twisted, W/Shield

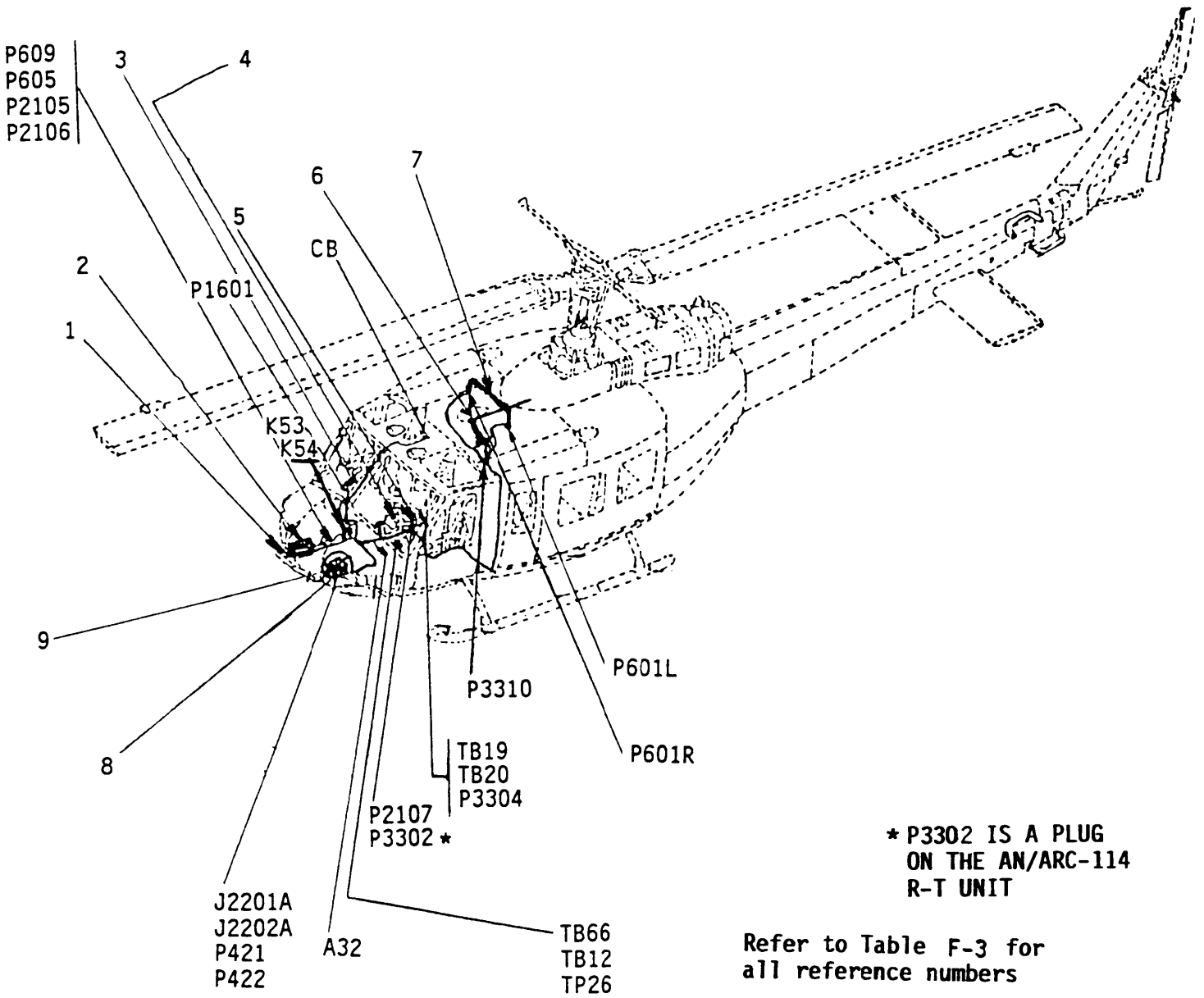

Figure F-3. VHF/FM Radio AN/ARC-54/131 (Sheet 1 of 2)

<u>DRAWING DESIGNATION</u>	<u>PART NUMBER</u>	<u>DESCRIPTION</u>
1	MT-1535/ARC-54 MT-3664/ARC-131	Mount Mount, Direct Replacement
2	RT-348/ARC-54 RT-823/ARC-131	Receiver-Transmitter Receiver-Transmitter, Direct Replacement
3	ID-1347()/ARN-82	Course Indicator
4	C-8157/ARC	Control-Indicator
5	C-3835/ARC-54 C-7088/ARC-131	Control Control, Direct Replacement
6	206-075-543-3	Antenna
7	AS-1922/ARC	Antenna, FM Homing
8	MT-3802/ARC	Mount
9	TSEC/KY-28 or TSEC/KY-58	Speech Security (KY-58 and KY-28 uses same wiring)

Figure F-3. VHF/FM Radio AN/ARC-54/131 (Sheet 2 of 2)

Table F-3. VHF/FM Radio AN/ARC-54/131

WIRE NUMBER	TYPE 2	END 1	PIN 1	END 2	PIN 1
RF400A20N	NO/S	P2106	1	GND	
RF400B20N	NO/S	P2106	2	GND	
RF400C20N	NO/S	P2106	3	GND	
RF401B22	NO/S	P2106	42	SPLICE	(RF401A22)
RF401C22	NO/S	P2106	41	SPLICE	(RF401A22)
RF401A22	NO/S	SPLICE	(RF401B22) (RF401C22)	P2107	v
RF402A22	NO/S	P2106	11	P2107	
RF403A22	NO/S	P2106	10	P2107	y
RF404D22	SHIELD	P2201A	G	SPLICE	(RF404C22)
RF404A22	SHIELD	P2106	13	SPLICE	(RF404D22)
RF404C22	NO/S	P2201A	<u>6</u>	SPLICE	
RF405A22	SHIELD	P2106	14	SPLICE	(RF405C22)
RF405C22	SHIELD	SPLICE	-	P421	H
RF406A22	SHIELD	P2106	6	P422	v
RF407A22	SHIELD	P2106	5	SPLICE	(RF407C22)
RF407C22	SHIELD	SPLICE	-	P421	K
RF408A22	NO/S	P2106	26	P2107	k
RF409A22	NO/S	P2106	31	P2107	m
RF410A22	NO/S	P2106	25	P2107	B̄B̄
RF411A22	NO/S	P2106	30	P2107	LL
RF412A22	NO/S	P2106	24	P2107	cc
RF413A22	NO/S	P2106	29	P2107	J
RF414A22	NO/S	P2106	23	P2107	G
RF415A22	NO/S	P2106	32	P2107	h
RF416A22	NO/S	P2106	37	P2107	i
RF417A22	NO/S	P2106	8	P2107	W̄
RF418A22	NO/S	P2106	9	P2107	x

Table F-3 VHF/FMRadio AN/ARC-54/L31 (Cont)

WI RE NUMBER	TYPE 2	END 1	PIN 1		PIN 1
RF419A22	NO/S	P2106	12	P2107	v
RF420A22	NO/S	P2106	4	P2107	K
RF421A22	NO/S	P2106	28	P2107	P
RF422A22	NO/S	P2106	33	P2107	R
RF423A22	NO/S	P2106	35	P2107	s
RF424A22	NO/S	P2106	22	P2107	T
RF425A22	NO/S	P2106	27	P2107	u
RF426A22	NO/S	P2107	DD	K53	xl
RF426B22	NO/S	K53	xl	K54	xl
RF426C22	NO/S	K54	xl	TB71	l
RF426D22	NO/S	TB71	2	P2106	16
RF427A22	SHI ELD	P2106	20	P2107	MM
RF428A20	NO/S	P2107	F	FL1	
RF429A20	NO/S	P2107		FL1	
RF430A20	NO/S	P2107	f	FL1	
RF428B20	SHI ELD	P2106	36	FL1	
RF429D20	SHI ELD	P2106	18	FL1	
RF430B20	SHI ELD	P2106	34	FL1	
RF431A22	SHI ELD	P2106	21	K53	Al
RF431B22	SHI ELD	K53	2	P1601	L
RF432A22	SHI ELD	P2106	17	P2107	t
RF433B22	NO/S	K53	cl	A32	i
RF433A22	SHI ELD	P2106	19	K53	C1
RF444A18	NO/S	TB19	5	CB31(FM)	
RF444B20	NO/S	P2107	c	TB19	5
RF444C20	NO/S	P2107	D	TB19	5
RF444D20	NO/S	P2107	E	TB19	5
RF445A22	SHI ELD	P2107	s	K53	D1
RF445B22	NO/S	K53	D1	A32	2
RF446A22	SHI ELD	P2107	NN	K53	B1
RF446B22	SHI ELD	K53	B2	P1601	M
RF447A22	NO/S	P2107	FF	K54	cl
RF447B22	NO/S	K54	cl	K54	Al
RF448A22	NO/S	P2107	GG	K54	D1
RF448B22	NO/S	K54	D3	K54	B1
RF449A22	NO/S	P2107	Q	TB19	4
RF450B22	SHI ELD	P2107	KK	TB66	4
RF450A20	NO/S	TB66	5	P421	J
RF451A22	SHI ELD	P2107	N	P3304	A
RF451B22	NO/S	J2201A	G	J2202A	F
RF452A22	SHI ELD	P2202A	A	TB20	4
RF452B22	SHI ELD	J2202A	A	P2107	Y
RF453A20N	NO/S	K53	X2	GND	-
RF453B20N	NO/S	K53	WI RE		
			SHI ELDS	GND	
RF454A20N	NO/S	K54	X2	GND	
RF455A20N	NO/S	P2106	WI RE	GND	
			SHI ELDS		

Table F-3. VHF /FM Radio AN/ARC-54:131 (Cont)

WI RE NUMBER	TYPE 2	END 1	PIN 1	END 2	PIN 1
RF458A20N	NO/S	P2107	WI RE SHI ELDS	GND	
RF461A22	NO/S	P2202A	E	(RF407A22)	SPLI CE
RF462A22	NO/S	P2201A	E	WI RE SHI ELDS	
RF463A22N	NO/S	J2202A	E	WI RE CAP	(RF603A22N]
RF603A20N	NO/S	(RF463 A22N)	GND		
RF464A22	NO/S	J2201A	E	(RF465A22N)	WI RE CAP
RF465A22N	NO/S	WI RE CAP	(RF464A22)	GND	
RF470A22N	SHI ELD	P2107	PP	TB26	2
RF471A22N	SHI ELD	P2107	w	TB26	2
RF472A22N	NO/S	P2107	WI RE SHI ELDS	TB26	2
RF404B22	SHI ELD	P2107	JJ	J2202A	F
RF405B22	SHI ELD	P2107	B	J2202A	H
RF406B22	SHI ELD	P2107	x	J2201A	v
RF407B22	SHI ELD	P2107	d	J2202A	K
RF434A	COAX	P609		P601L	
RF435A	COAX	P605		P601R	
RF436A	COAX	P2105		P3310	
KY28-10A20	NO/S	P2106	3i	P2201A	S
KY28-11A22	NO/S	P2106	7	P2201A	P
KY28-12A20	NO/S	P2106	39	P2201A	w
KY28-13A22	NO/S	P2106	15	P2201A	D
KY28-14A22	NO/S	P2106	44	P2201A	M
ARC114-21A22	SHI ELD	P2107	c	P3302	x
ARC114-22A22	SHI ELD	P2107	A	P3302	Y
ARC114-8A22	SHI ELD	P2107	u	P3302	H
ARC114-23A22	SHI ELD	P2107	HH	P3302	z
L125A22	NO/S	P2107	a	TB12	1
L128A20N	NO/S	P2107	b	TP26	7
RF448C22	NO/S	P1601	R	K54	B-2
RF447C22	NO/S	P1601	S	K54	A-2
RF600A20	NO/S	P2201A	c	J600	20

1 Underlined Connector Pin Letters Denote Lower Case

2 Denote: NO/S--No Shield

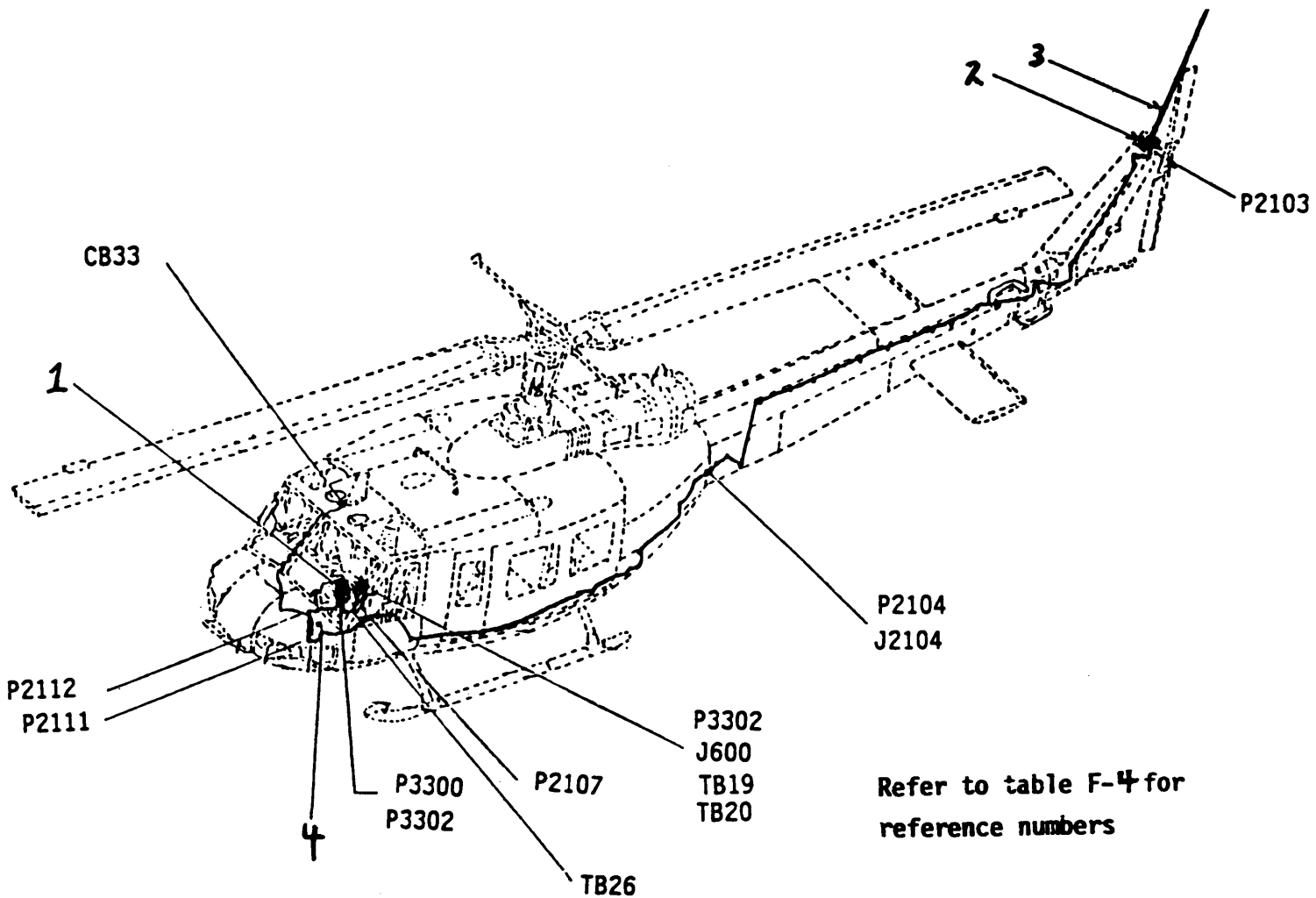

Figure F-4. VHF/FM Radio AN/ARC-114 (Sheet 1 of 2)

<u>DRAWING DESIGNATION</u>	<u>PART NUMBER</u>	<u>DESCRIPTION</u>
1	AN/ARC-114A	Receiver-Transmitter
2	CU-942B/ARC	Antenna Coupler
3	AS-1703/AR	Antenna, Whip
4	212-075-328-3	FM Filter

Figure F-4. VHF/FM Radio AN/ARC-114 (Sheet 2 of 2)

Table F-4. VHF/FM Radio AN/ARC 114

WIRE NUMBER	TYPE 2	END 1	PIN 1	END 2	PIN 1
ARC114-2A22	NO/S	P3302	B	P3302	v
ARC114-3A22	NO/S	P3302	c	SPLICE	
ARC114-4A20	NO/S	P3302	D	CB33	
ARC114-5A20N	NO/S	P3302	E	TB26	4
ARC114-8A22	SHIELD	P3302	H	P2107	u
ARC114-10A22 (RED)	PR/S	P3302	K	P3303	R
ARC114-11A22 (BLK)	PR/S	P3302	L	P3303	e
ARC114-10B22	SHIELD	P3303	L	TB20	7
ARC114-11B22N	SHIELD	P3303	b	TB26	1
ARC114-14A20N	NO/S	P3302	P	TB26	4
ARC114-21A22	SHIELD	P3302	x	P2107	c
ARC114-22A22	SHIELD	P3302	Y	P2107	A
ARC114-23A22	SHIELD	P3302	z	P2107	HH
ARC114-27A22	SHIELD	P3302	d	J600	26
ARC114-27B22	SHIELD	J600	d	TB20	12
ARC114-28A22N	SHIELD	P3302	e	TB26	1
ARC114-28B22N	NO/S	TB26	i	GND	-
ARC114-31A22	NO/S	P3302	h	P3304	h
ARC114-60A22N	NO/S	P3302	CAP LUG	TB26	i
ARC114-61A22	NO/S	P3303	s	CAP LUG	SHIELD
ARC114-61B22	NO/S	P3303	M	CAP LUG	SHIELD
ARC114-101A	COAX	P3300		P2112	
ARC114-105A	COAX	P2111		P2104	
ARC114-105B	COAX	J2104		P2103	

1 Underlined Connector Pin Letters Denote **Lower Case**

2 Denotes: NO/S--No Shield
PR/S--Parallel, W/Shield

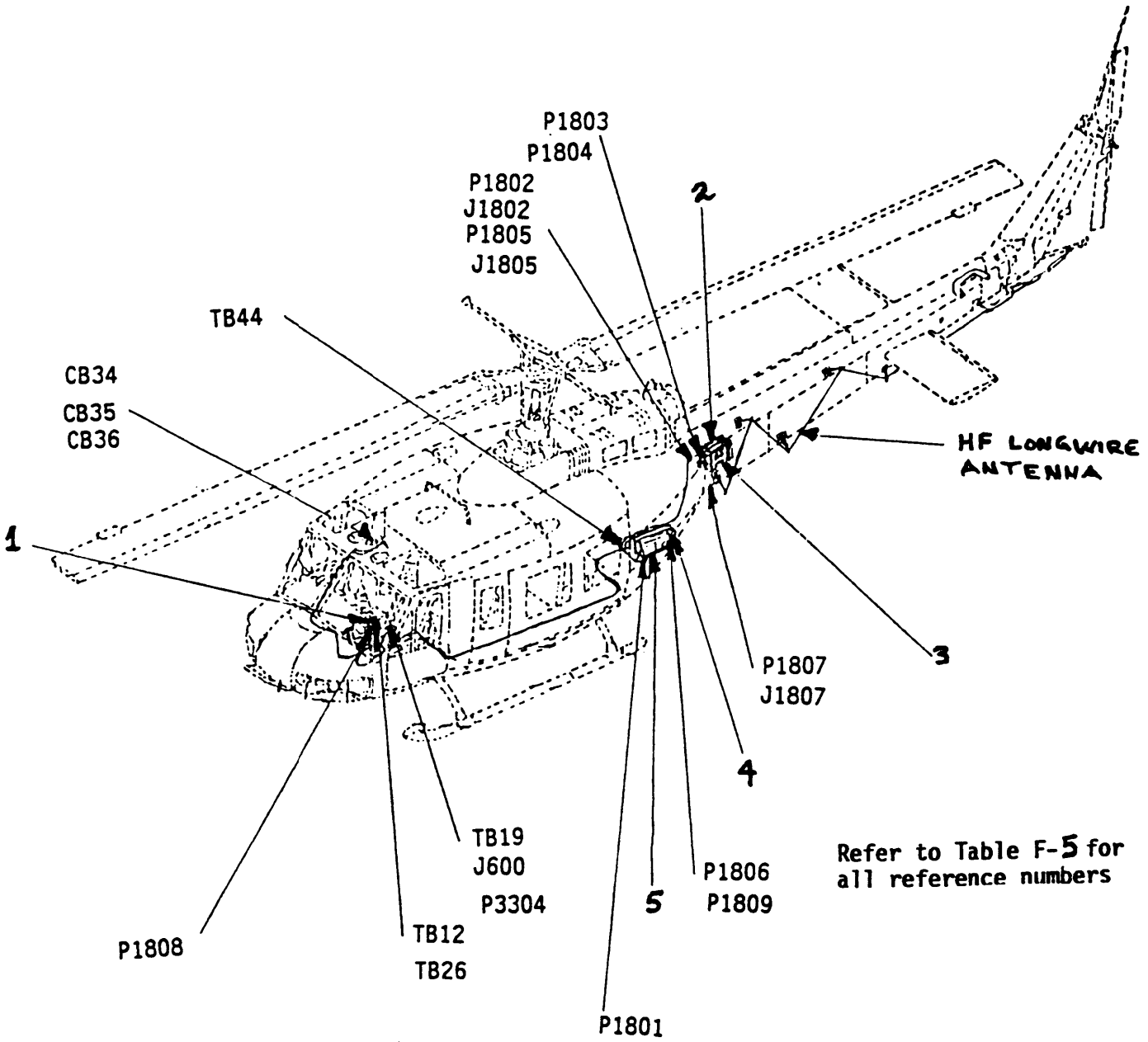

Figure F-5. HF Radio AN/ARC-102 (Sheet 1 of 2)

<u>DRAWING</u> <u>DESIGNATION</u>	<u>PART</u> <u>NUMBER</u>	<u>DESCRIPTION</u>
1	C-3940/ARC-94	Control
2	CU-1658A/ARC	Coupler, Antenna
3	MT-3772AIA	Mount
4	PP-3702/ARC-102	Power-Inverter, Mounting
5	RT-698/ARC-102	Receiver-Transmitter

Figure F-5. HF Radio AN/ARC-102 (Sheet 2 of 2)

Table **F-5.** HF Radio AN/ARC 102

WIRE NUMBER	TYPE 2	END 1	PIN 1	END 2	PIN 1
RL2575A20	NO/S	P1806	36	P1808	E
RL2576A20	NO/S	P1806	35	P1808	D
RL2577A20	NO/S	P1806	34	P1808	c
RL2578A20	NO/S	P1806	33	P1808	B
RL2579A20	NO/S	P1806	32	P1808	A
RL2580A20	NO/S	P1806	48	P1808	N
RL2581A20	NO/S	P1806	47	P1808	M
RL2582A20	NO/S	P1806	46	P1808	L
RL2583A20	NO/S	P1806	45	P1808	K
RL2584A20	NO/S	P1806	52	P1808	T
RL2585A20	NO/S	P1806	51	P1808	s
RL2586A20	NO/S	P1806	50	P1808	R
RL2587A20	NO/S	P1806	49	P1808	P
RL2588A20	NO/S	P1806	41	P1808	J
RL2589A20	NO/S	P1806	40	P1808	H
RL2590A20	NO/S	P1806	39	P1808	G
RL2591A20	NO/S	P1806	38	P1808	F
RL2592A20	NO/S	P1806	24	P1808	i
RL2593A20	NO/S	P1806	u	TB44	7
RL2593B20	NO/S	TB44	7	P1809	1
RL2593C20	NO/S	TB44	7	P1806	59
RL2594A20	NO/S	P1806	30	P1808	Z
RL2597A20	NO/S	P1806	25	P1808	v
RL2599A18	SHI ELD	P1806	56	P1805	E
RL2599B18	SHI ELD	P1805	E	P1804	L
RL2600A8	NO/S	CB34		TB44	4
RL2600B20	NO/S	P1806	17	TB44	1
RL2600C20	NO/S	P1806	3	TB44	2
RL2600D20	NO/S	P1806	2	TB44	3
RL2600E20	NO/S	P1806	1	TB44	2
RL2600F20	NO/S	P1806	15	TB44	2
RL2600G20	NO/S	P1806	14	TB44	3
RL2600H20	NO/S	P1806	13	TB44	3
RL2601A20	SHI ELD	P1806	55	TB44	10
RL2601B20	SHI ELD	TB44	10	P1805	c
RL2601D20	SHI ELD	J1805	c	P1804	K
RL2601C20	SHI ELD	TB44	10	P1808	g

Table F-5. HF Radi o AN/ARC-I 02 (Cont)

WI RE NUMBER	TYPE 2	END 1	PIN 1	END 2	PIN 1
RL2602A18	NO/S	CB35	-	TB44	6
RL2602B12	NO/S	CB34	-	BUSBAR	-
RL2602C18	NO/S	P1806	16	TB44	6
RL2602D18	NO/S	P1806	4	TB44	6
RL2603A16	NO/S	CB36	-	TB44	5
RL2603B18	NO/S	TB44	5	P1809	2
RL2603C18	NO/S	TB44	5	P1809	3
RL2606A20	SHI ELD	P1806	11	P1805	B
RL2606B20	SHI ELD	J1805	B	P1804	A
RL2607A20	SHI ELD	P1806	5	P1805	F
RL2607B20	SHI ELD	J1805	F	P1804	s
RL2609A20	SHI ELD	P1806	26	P1805	D
RL2609B20	SHI ELD	J1805	D	P1804	F
RL2611A20	NO/S	P1808	<u>k</u>	TB19	8
RL2614A20	SHI ELD	P1806	10	P1805	A
RL2614B20	SHI ELD	J1805	A	P1804	H
RL2615A20	NO/S	P1808	<u>m</u>	TB19	8
RL2615B20	NO/S	TB19	<u>8</u>	P3304	E
RL2616A	COAX	P1801	-	P1802	-
RL2616B	COAX	J1802	-	P1803	-
RL2618A20	SHI ELD	P1806	27	P1809	9
RL2618B20	SHI ELD	P1806	27	P1805	G
RL2618B20	SHI ELD	J1802	G	P1804	D
RL2619A20	SHI ELD	P1806	12	P1809	5
RL2620A20N	NO/S	P1809	6	P1806	GND
RL2620B20N	NO/S	P1809	7	P1806	GND
RL2620C20N	NO/S	P1809	4	P1806	GND
RL2620D8N	NO/S	P1806	GND	-	GND
RL2620E20N	NO/S	P1808	<u>r</u>	TB26	9
RL2620F20N	NO/S	-	GND	SPLI CE	-
RL2620G20	NO/S	P1804	G	SPLI CE	-
RL2620H20	NO/S	J1805	H	SPLI CE	SHI ELDS
RL2620J20	NO/S	P1805	H	SPLI CE	SHI ELDS
RL2621A20	NO/S	P1808	<u>p</u>	P1806	31
RL2622A20N	NO/S	P1808	<u>e</u>	TB26	6
RL2623A22(BLK)	PR/S	P1806	57	J600	SPLI CE
RL2624A22(RED)	PR/S	P1806	58	J600	19
RL2625A22(BLK)	PR/S	P1806	53	J600	SPLI CE
RL2626A22(RED)	PR/S	P1806	37	J600	T
RL2627A20N	NO/S	P1806	CAP LUG	SHI ELDS	GND
RL2627B20	NO/S	P1806	CAP LUG	SHI ELDS	SHI ELDS
RL2627C20N	NO/S	P1809	CAP LUG	SHI ELDS	GND
RL2700A	NO/S	P1803	ANT	P1807	-
RL2700	NO/S	J1807	ANT	TAI LBOOM	-
L126A20	NO/S	P1808	<u>d</u>	TB12	2

1 Underlined Connector Pin Letters Denote Lower Case

2 Denotes: NO/S--No Shi el d
PR/S--Pai r Twi sted, W/Shi el d

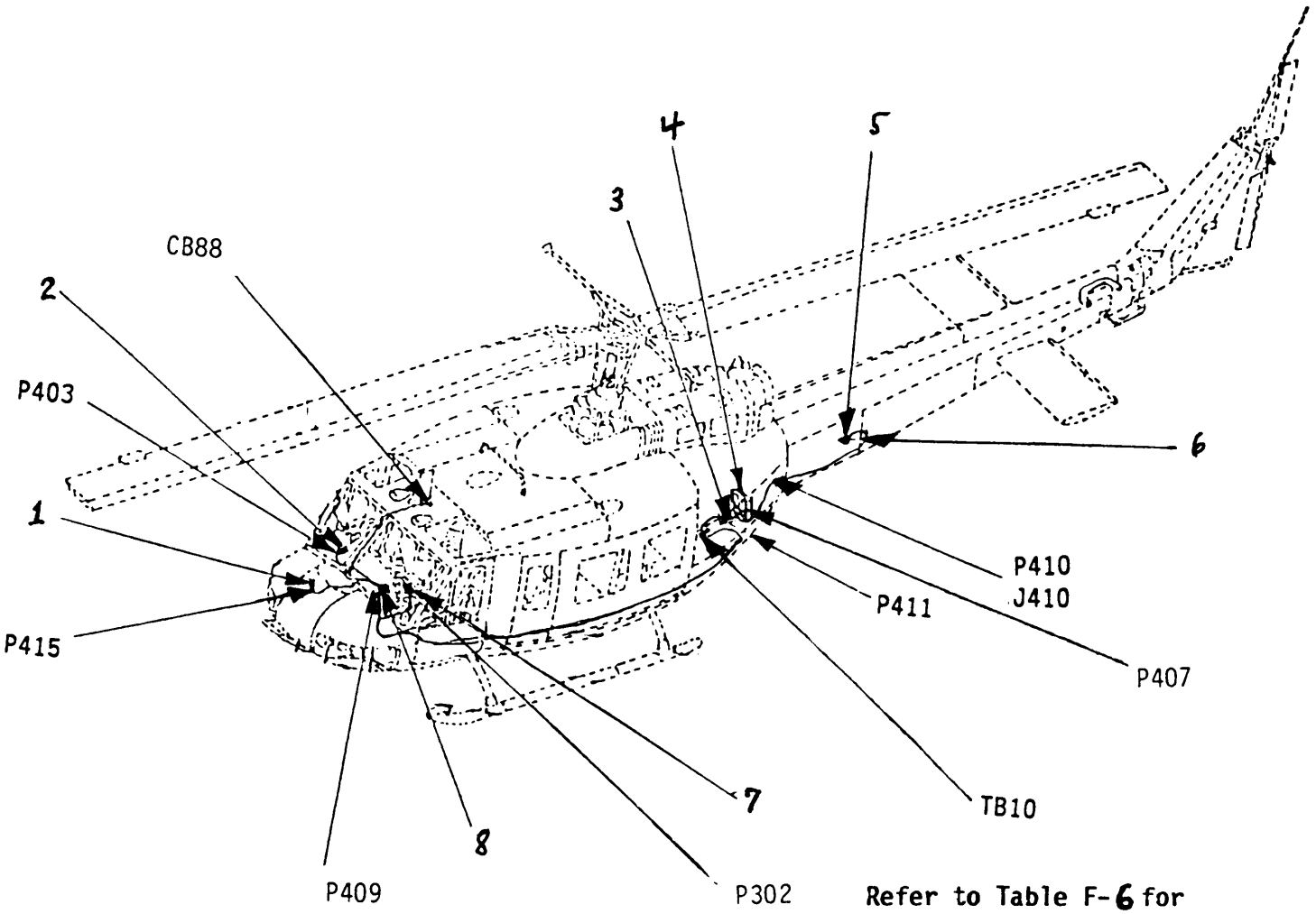

Refer to Table F-6 for all reference numbers

Figure F-6. GYRO Compass J-2, AN/ASN-430 (Sheet 1 of 2)

<u>DRAWING DESIGNATION</u>	<u>PART NUMBER</u>	<u>DESCRIPTION</u>
1	AM-3209/ASN	Servoamplifier
2	ID-9980/ASN	Radio Magnetic Indicator
3	CN-9980/ASN-43	Directional GYRO
4	R-1391/ARN-83	Radio Receiver
5	CN-405/ASN	Compensator
6	T-611/ASN	Compass Transmitter
7	C-6899/ARN-83	Control, Direction Finder
8	ID-250()/ARN	Radio Magnetic Indicator

Figure F-6. Gyrocompass J-2, AN/ASN-430 (Sheet 2 of 2)

Table F-6. **GYRO Compass** J-2, AN/ASN-430

WIRE NUMBER	TYPE 2	END 1	PIN 1	END 2	PIN 1
F2A22(YEL)	TWT/S	P403	42	P410	B
F2B22(YEL)	TWT/S	J410	B	T-611	B
F3A22(BLU)	TWT/S	P403	43	P410	c
F3B22(BLU)	TWT/S	J410	c	T611	c
F4A22(GRN)	TWT/S	P403	44	P410	A
F4B22(GRN)	TWT/S	J410	A	T-611	A
F5C22	NO/S	TB10	6	P410	D
F5D22	NO/S	J410	D	T-611	D
F5F22	NO/S	T-611	D	T-611	F
F5G22	NO/S	J410	F	SPLICE	SHIELDS
F5H22	NO/S	T-611	F	SPLICE	SHIELDS
F5J22	NO/S	P410	F	SPLICE	SHIELDS
F42A22(GRN)	TWT/S	P411	J	P403	3
F43A22(YEL)	TWT/S	P411	G	P403	2
F44A22(BLU)	TWT/S	P411	11	P403	1
F22A22	NO/S	P411	M	P410	E
F22B22	NO/S	J410	E	T-611	E
F24A22	SHIELD	P403	45	P411	D
F50A22	NO/S	P403	46	P411	B
F65A22	NO/S	P403	5	P415	6
F67B22	NO/S	P403	4	SPLICE	
F67A22(BLK)	PR/S		SPLICE	P415	3
F60A22	NO/S	P415	10	P403	54
F61A22	NO/S	P415	13	P403	8
F62A22	NO/S	P415	14	P403	9
F70A22N	NO/S	P403	55	GND	

1 Underlined Connector Pin Letters Denote Lower Case

2 Denotes: NO/S--No Shield
PR/S--Pair Twisted, W/Shield
TWT/S--Three Wire Twisted, W/Shield

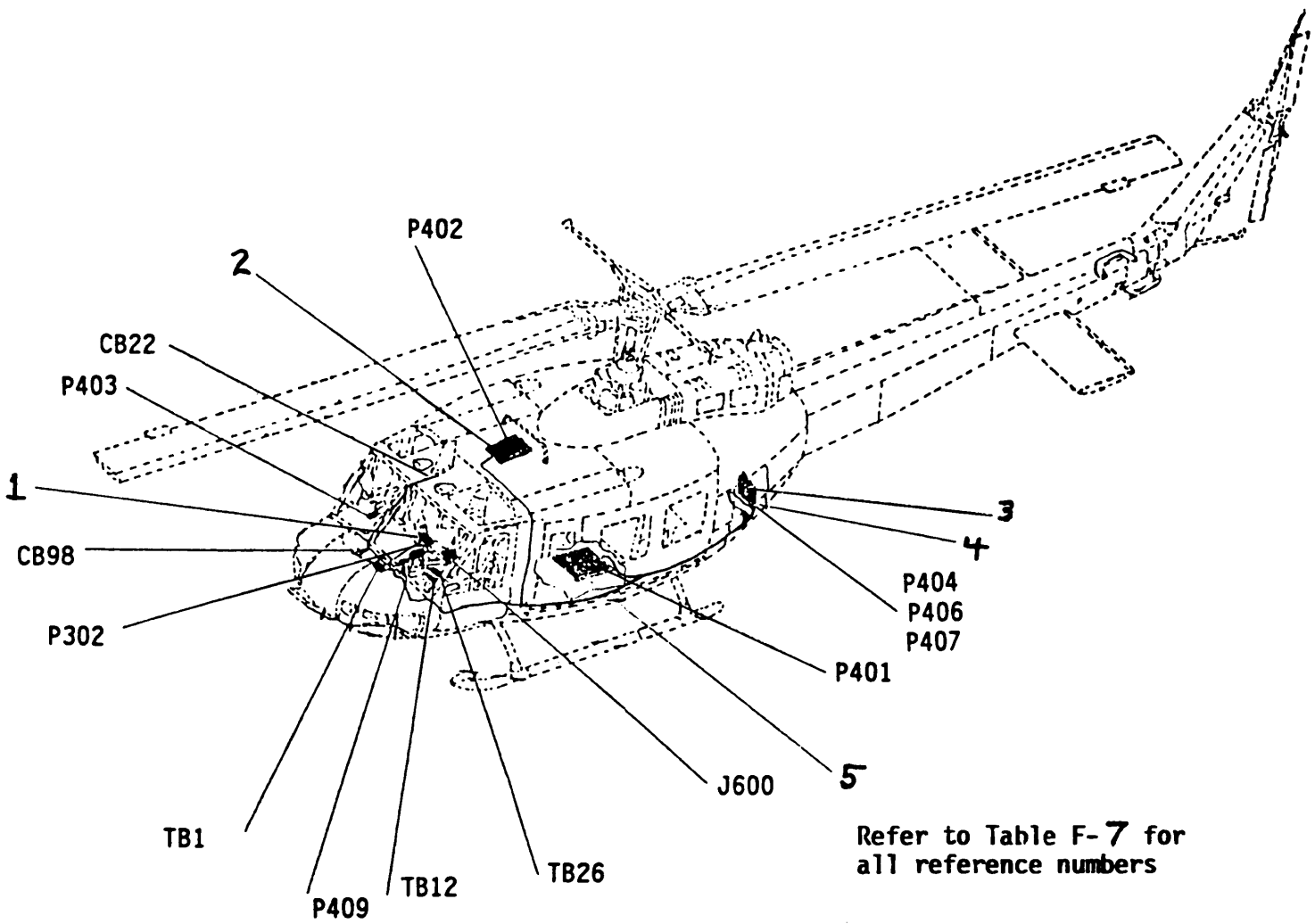

Figure F-7. Direction Finder Set AN/ARN-83 (Sheet 1 of 2)

<u>DRAWING DESIGNATION</u>	<u>PART NUMBER</u>	<u>DESCRIPTION</u>
1	C-6899/ARN-83	Direction Finder Control
2	AS-1863/ARN-83	Antenna, Loop
3	R-1391/ARN-83	Radio Receiver
4	MT-3605/ARN-83	Mount
5	205-075-325-1	ADF Sense Antenna

Figure F-7. Direction Finder Set AN/ARN-83 (Sheet 2 of 2)

Table F - 7 Direction Finder Set, AN/ARN -83

WIRE NUMBER	TYPE 2	END 1	PIN 1	END 2	PIN 1
RN354B22	NO/S	P403	29	TB1	7
RN354C22	NO/S	TB1	7	P409	T
RN355B22	NO/S	P403	29	TB1	6
RN355C22	NO/S	TB1	6	P409	U
RN361A20	NO/S	P407	36	SPLICE	-
RN361B20	NO/S	P302	M	SPLICE	-
RN5361C20N	NO/S	SPLICE		TB26	5
RN362A22	NO/S	P407	30	P302	D
RN363A22	NO/S	P407	31	P302	R
RN364A22	NO/S	P407	32	P302	S
RN365A22	NO/S	P407	12	P302	E
RN366A22	NO/S	P407	13	P302	I
RN367A22	NO/S	P407	14	P302	C
RN368A22(YEL)	TWT/S	P407	9	P302	X
RN369A22(BLU)	TWT/S	P407	10	P302	Y
RN370A22(GRN)	TWT/S	P407	11	P302	Z
RN371A22	NO/S	P407	29	P302	1
RN372A22	NO/S	P407	28	P302	H
RN373A22	NO/S	P407	27	P302	K
RN374A22(GRN)	TWT/S	P407	33	P302	F
RN375A22(BLU)	TWT/S	P407	34	P302	I
RN376A22(YEL)	TWT/S	P407	35	P302	F
RN377A22	NO/S	P407	15	P302	H
RN378A22	NO/S	P407	22	P302	t
RN379A20	NO/S	P302	K	CB22	1
RN382A22	NO/S	P302	G	TB12	1
RN383A22	NO/S	P302	b	TB12	1
RN384A22(RED)	PR/S	P302	W	J600	18
RN385A22(BLK)	PR/S	P302	v	J600	28
RN386A22(RED)	PR/S	P407	23	P302	T
RN387A22(BLK)	PR/S	P407	24	P302	U
RN388A20	NO/S	P407	26	P302	L
RN389A20N	NO/S	P302	a	TB26	5
RN389B22N	NO/S	P407	17	TB26	10
RN389C20N	NO/S	P407	16	TB26	10
RN390A22	NO/S	CB98		SPLICE	-
RN390B22	NO/S	SPLICE		SPLICE	-

Table F-7 • Direction Finder Set, AN/ARN-83 (Cont)

WIRE NUMBER	TYPE 2	ENDER 1	PIN 1	END 2	PIN 1
RN5390C22	NO/S	SPLICE		P407	8
RN5390D22	NO/S	SPLICE		P407	18
RN5390E22	NO/S	SPLICE		P403	27
RN5390F22	NO/S	SPLICE		P302	J
RN5390G22	NO/S	P409	M	P403	53
RN5391A22N	NO/S	P407	21	GND	
RN5392A22	NO/S	P407	20	TB1	9
RN5392B22	NO/S	TB1	9	P403	22
RN5392C22	NO/S	P403	31	P409	N
RN5393A22	NO/S	P407	19	TB1	8
RN5393B22	NO/S	TB1	8	P403	23
RN5393C22	NO/S	P403	32	P409	P
RN5395A	MOLDED CABLE	P406	c E F	P401	SENSE ANT
• • •	MOLDED CABLE	P404		P402	LOOP ANT

1 Underlined Connector Pin Letters Denote Lower Case

2 Denotes: NO/S--No Shield
PR/S--Pair Twisted, W/Shield
TWTS/--Three Wire Twisted, W/Shield

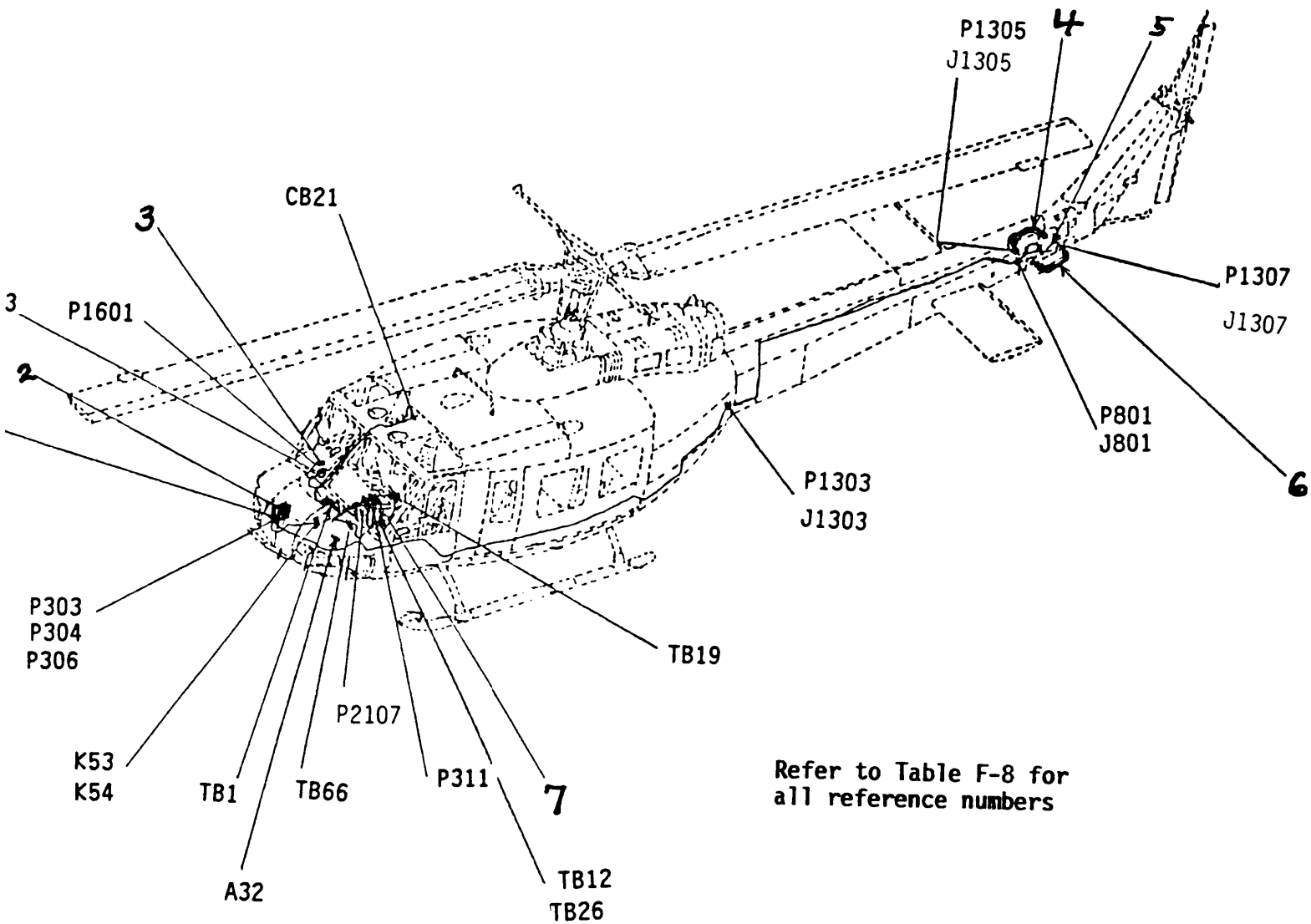

Refer to Table F-8 for
all reference numbers

Figure F-8. VOR/MG/GS AN/ARN-820 (Sheet 1 of 2)

<u>DRAWING DESIGNATION</u>	<u>PART NUMBER</u>	<u>DESCRIPTION</u>
1	MT-3600/ARN-82	Mount, Radio
2	R-1388/ARN-820	Radio Receiver
3	ID-13470/ARN-82	Course Indicator
4	As-1304/ARN	Antenna
5	5995-00-858-6552	Spider, Coax Assembly (05211)
6	AS-1304/ARN	Antenna
7	C-6873/ARN-82	Radio Set Control

Figure F-8. VOR/MG/GS AN/ARN-820 (Sheet 2 of 2)

Table F-8 VOR/MG GSAN/ARN - 82 ()

WI RE NUMBER	TYPE 2	'END 1	PIN 1	END 2	PIN 1
RN5280A	COAX	P303		P1303	
RN5280B	COAX	J1303		P801	
SPYDER	COAX	J801	-	P1305	
				P1307	
R N5281A22 (RED)	PR/S	P311	b	P304	L
R N5282A22 (BLK)	PR/S	P311	c	P304	N
R N5283A22	NO/S	P311	P	P304	J
R N5284A22	NO/S	P311	Z	CB21	
R N5285A20N	NO/S	P304	X	TB26	10
R N5285B20N	NO/S	TB26	10	P311	SPLI CE
R N5285C20	NO/S	P311	h	P311	SPLI CE
R N5286A22	NO/S	P311	H	TB12	3
R N5287A22 (RED)	PR/S	P311	d	TB19	7
R N5288A22 (BLK)	PR/S	P311	e	TB19	6
R N5288B22N	NO/S	TB19	6	TB66	2
R N5290A22	NO/S	P304	A	SPLI CE	
R N5290B22	NO/S	P304	R	SPLI CE	
R N5290C20	NO/S	SPLI CE	-	P311	M
R N5291A22	NO/S	P311	a	P304	K
R N5292A22	NO/S	P311	Y	P304	k
R N5293A22	NO/S	P311	L	P304	t
R N5294A22	NO/S	P311	g	P304	t
R N5295A22	NO/S	P311	C	P304	p
R N5296A22	NO/S	P311	D	P304	p
R N5297A22	NO/IS	P311	E	P304	p
R N5298A22	NO/S	P311	f	P304	i
R N5299A22	NO/S	P311	B	P304	j
R N5300A22	NO/S	P311	V	P304	w
R N5301A22	NO/S	P311	X	P304	v
R N5302A22	NO/S	P311	G	P304	u
R N5303A22	NO/S	P311	F	P304	T
R N5304A22	NO/S	P311	W	P304	s
R N5305A22	NO/S	P304	m	TB66	10
R N5305B22	NO/S	P304	B	TB66	10
R N5305C22	NO/S	P304	P	TB66	10
R N5305D22	NO/S	K53	D-3	A32	

Table F-8. VOR/MG/GS AN/ARN-820 (Cont)

WI RE NUMBER	TYPE 2	END 1	PIN 1	END 2	PIN 1
RN5305E22	SHI ELD	P1601	J	K53	D-2
RN5305F22	NO/S	A32	3	TB66	10
RN5306A22	NO/S	P304	<u>n</u>	K53	c-3
RN5306B22	SHI ELD	K53	<u>C-2</u>	P1601	K
RN5306C22	NO/S	P304	<u>d</u>	A32	4
RN5307A22	NO/S	P304	<u>b</u>	K54	c-3
RN5307B22	NO/S	K54	C-2	P1601	P
RN5308A22	NO/S	P304	<u>a</u>	SPLI CE	
RN5308B22	NO/S	P304	<u>c</u>	SPLI CE	
RN5308C22	NO/S	SPLI CE	-	K54	D-3
RN5308D22	NO/S	K54	D-2	P1601	N
RN5309A22	NO/S	P1601	H	P304	H
RN5310A22	NO/S	P304	c	P1601	c
RN5311A22	NO/S	P304	D	P1601	D
RN5312A22	NO/S	P304	E	P1601	E
RN5313A22	NO/S	P304	F	P1601	F
RN5314A22	NO/S	P304	G	P1601	G
RN5315A22	NO/S	P304	z	P1601	T
RN5316A22	NO/S	P304	Y	P1601	u
RN5352A22	NO/S	P306	G	TB1	12
RN5354A22	NO/S	P306	H	TB1	7
RN5354B22	NO/S	TB1	7	P403	29
RN5354C22	NO/S	TB1	7	P409	T
RN5355A22	NO/S	P306	K	TB1	6
RN5355B22	NO/S	TB1	6	P403	30
RN5355C22	NO/S	TB1	6	P409	u
RN5356A20	NO/S	P306	J	CB	
F80A22	NO/S	P306	c	P403	18
F81A22	NO/S	P306	D	P403	19
F82B22N	NO/S	P306	E	GND	

1 Underlined Connector Pin Letters Denote Lower Case

2 Denotes: NO/S--No Shi el d
PR/S--Pai r Twi sted, W/Shi el d

Figure F-9. DMEAW/ARN-124 (V-Only) (Sheet 1 of 2)

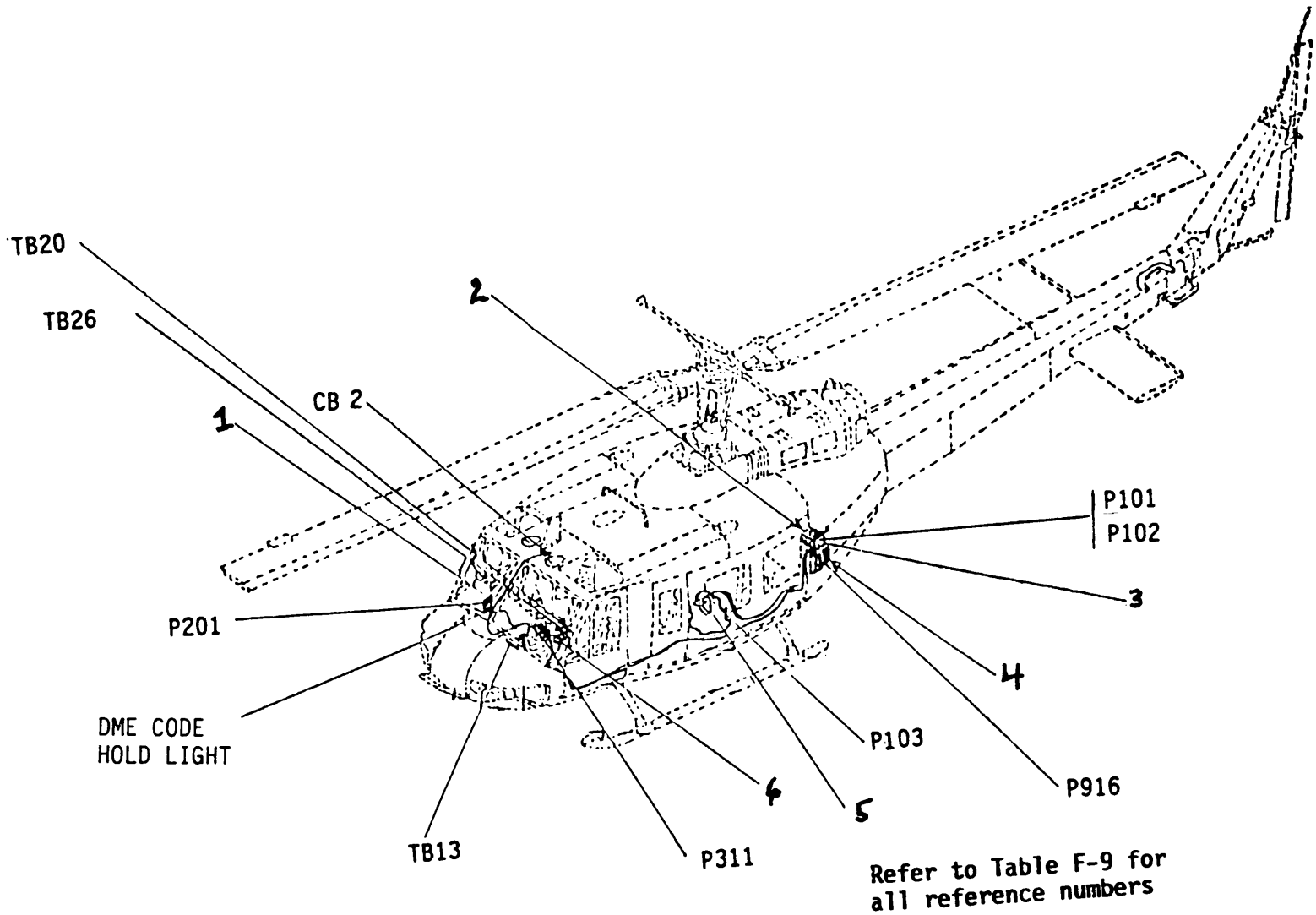

<u>DRAWING DESIGNATION</u>	<u>PART NUMBER</u>	<u>DESCRIPTION</u>
1	ID-2192/ARN-124	Control -Indicator
2	RT-1294/ARN-124	Receiver-Transmitter
3	MT-6034/ARN-124	Mount
4	RT-8590/APX-72	Receiver-Transmitter
5	AT-7411A	Antenna
6	C-6873B/ARN-82	Control

Figure F-9. DME ANMRN-124 (V-Only) (Sheet 2of2)

Table F-9. DME ANMRN - 1 2 4(V-Only)

<u>WIRE NUMBER</u>	<u>TYPE 2</u>	<u>END 1</u>	<u>PIN 1</u>	<u>END 2</u>	<u>PIN 1</u>
ARN124-1A22	NO/S	P102	37	P311	R N O t t i n g P i n 1
ARN124-2A22	NO/S	P102	39	P311	
ARN124-3A22	NO/S	P102	41	P311	
ARN124-4A22	NO/S	P102	42	P311	
ARN124-5A22	NO/S	P102	43	P311	
ARN124-6A22	NO/S	P102	47	P311	
ARN124-7A22	NO/S	P102	49	P311	
ARN124-8A22	NO/S	P102	50	P311	
ARN124-9A22	NO/S	P102	46	P311	
ARN124-10A22	NO/S	P102	45	P311	
ARN124-11A20 (WHT/RED)	TWT/S	P102	20	P201	
ARN124-12A20 (WHT/BLU)	TWT/S	P102	4	P201	24
ARN124-13A20 (WHT/YEL)	TWT/S	P102	7	P201	9
ARN124-14A20N	NO/S	P102	13	SPLICE	SP1
ARN124-14B20N	NO/S	SPLICE	SP1	SPLICE	SP4
ARN124-14C20N	NO/S	SPLICE	SP4	P201	2
ARN124-14D20N	NO/S	SPLICE	SP4	P201	19
ARN124-14E20N	NO/S	SPLICE	SP1	SPLICE	SP2
ARN124-15A22	NO/S	P201	36	P201	8
ARN124-16A22N	NO/S	P102	11	P201	32
ARN124-17A20N	NO/S	P102	23	P201	26
ARN124-18A22	NO/S	P102	38	P201	10
ARN124-19A22 (WHT/RED)	PR/S	P102	34	P201	17
ARN124-20A22 (WHT/BLU)	PR/S	P102	35	P201	36
ARN124-21A22N	NO/S	P102	18	SPLICE	SHIELDS
ARN124-23A22N	NO/S	P201	35	SPLICE	SHIELDS
ARN124-24A22 (WHT/RED)	PR/S	P102	3	P201	15
ARN124-25A22 (WHT/BLU)	PR/S	P102	1	SPLICE	SP3
ARN124-25B22	NO/S	SPLICE	SP3	P201	34
ARN124-26A22N	NO/S	P102	31	SPLICE	SHIELDS

Table F-9. DME AN/ARN-124 (V-Only) (Cont)

WIRE NUMBER	TYPE 2	END 1	PIN 1	END 2	PIN 1
ARN124-27A20	NO/S	CB2	-	LIGHT, DME CODE HOLD	1
ARN124-28A20	SHIELD	P102	15	P916	12
ARN124-29A20	SHIELD	P102	32	P916	11
ARN124-30A22	NO/S	P102	16	P201	22
ARN124-31A22	NO/S	P102	17	P201	20
ARN124-32A20 (WHT/BLU)	PR/S	P102	5	P201	33
ARN124-33A20N	NO/S	P102	10	SPLICE	SP2
ARN124-33B20N (WHT/RED)	PR/S	SPLICE	SP2	SPLICE	SP5
ARN124-33C20N	NO/S	SPLICE	SP5	P201	28
ARN124-33D20N	NO/S	SPLICE	SP5	TB26	9
ARN124-33E20N	NO/S	TB26	9	LIGHT, DME CODE HOLD	3
ARN124-34A20	NO/S	P102	6	CB	-
ARN124-37A22	SHIELD	RESIS- TOR BOARD	2	TB26	3
ARN124-37B22	NO/S	SPLICE	SP3	TB26	3
ARN124-38A20N	NO/S	LIGHT, DME CODE HOLD	2	P201	25
ARN124-40A22	NO/S	P201	6	P311	S
ARN124-41A22	NO/S	P201	11	P311	K
ARN124-42A20	NO/S	P201	18	TB13	1
ARN124-45A22	SHIELD	RESIS- TOR BOARD	4	P201	16
ARN124-46A22	SHIELD	RESIS- TOR BOARD	6	TB20	8
RN5285B22	NO/S	P311	<u>h</u>	TB26	9
ARN124-101	COAX	P101	-	P103	ANT

1 Underlined Connector Pin Letters Denote Lower Case

2 Denotes: NO/S--No Shield
PR/S--Pair Twisted, W/Shield
TWT/S--Three Wire Twisted, W/Shield

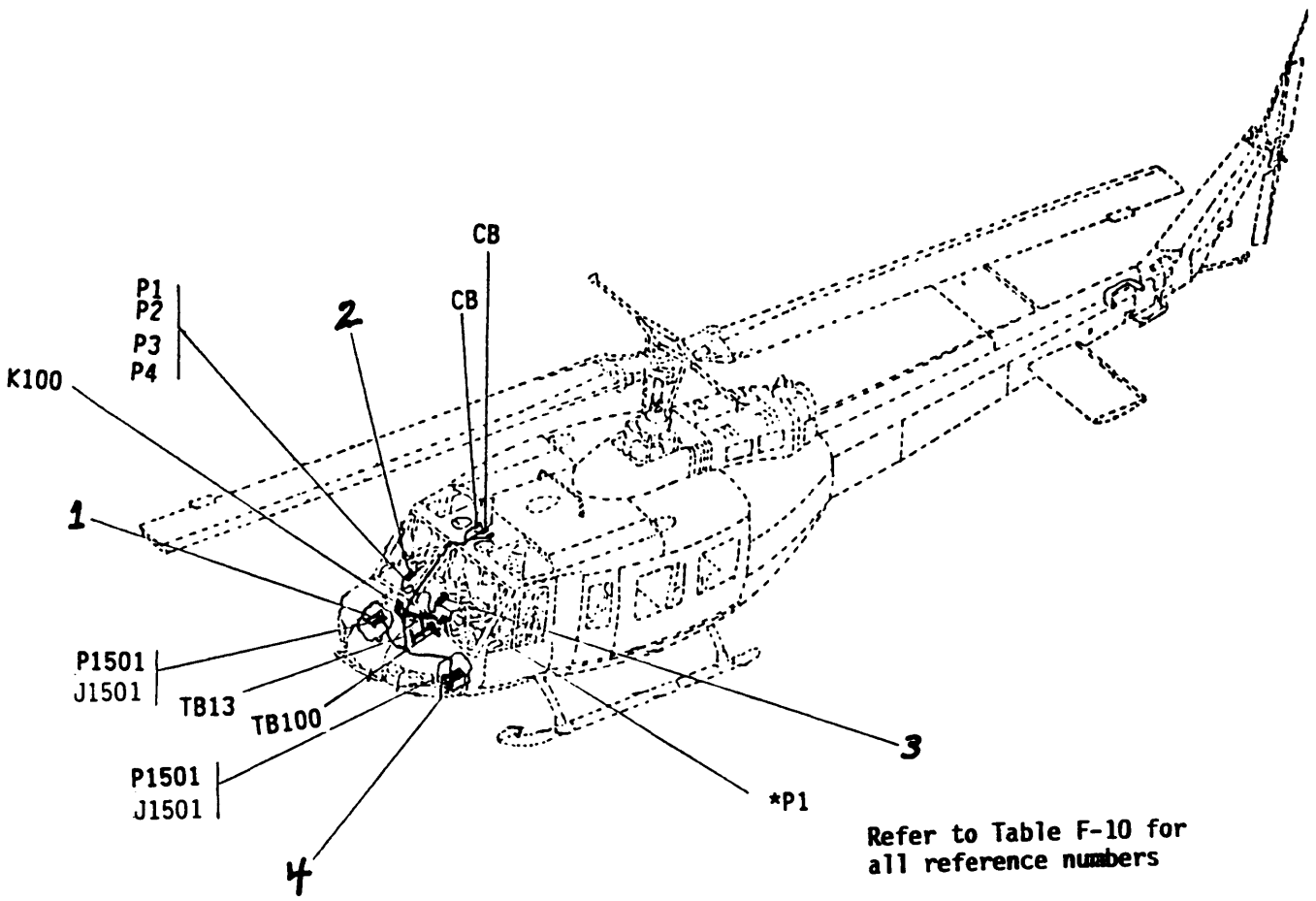

Figure F-10. Radar Altimeter AN/APR-209 (V-Only) (Sheet 1 of 2)

<u>DRAWING</u> <u>DESIGNATION</u>	<u>PART</u> <u>NUMBER</u>	<u>DESCRIPTION</u>
1	AS-2595/APN-194(V)	Antenna
2	RT-1115/APN-209	Receiver-Transmitter, Height Indicator
3	ID-1917/APN-209	Height Indicator
4	AS-2595/APN-194(V)	Antenna

Figure F-10. Radar Altimeter AN/APR-209 (V-Only) (Sheet 2 of 2)

Table F-10. Radar Altimeter AN/APR-209 (V-Only)

WIRE NUMBER	TYPE 2	END 1	PIN 1	END 2	PIN 1
APN209-1A22	NO/S	P1	7	K100	3
APN209-1B22	NO/S	K100	1	J3	K
APN209-1C22	NO/S	P3	K	TB13	9
APN209-7A22	NO/S	P1	9	CB	-
APN209-7B22	NO/S	CB	-	*P1	1
APN209-8A22N	NO/S	P1	3	GND	-
APN209-8B22N	NO/S	GND	-	*P1	2
APN209-13A22	NO/S	P2	8	*P1	16
APN209-14A22	NO/S	P2	13	*P1	21
APN209-15A22	NO/S	P2	3	*P1	15
APN209-16A22	NO/S	P2	2	*P1	9
APN209-17A22	NO/S	P2	11	*P1	5
APN209-18A22 (RED)	PR/S	P2	12	*P1	19
APN209-19A22 (RED)	PR/S	P2	4	*P1	11
APN209-20A22	NO/S	*P1	6	K100	6
APN209-20B22	NO/S	K100	8	J3	L
APN209-20C22	NO/S	P3	L	TB13	4
APN209-23A22	NO/S	P2	5	*P1	3
APN209-24A22	NO/S	P2	6	*P1	4
APN209-34A22 (BLU)	PR/S	P2	10	*P1	20
APN209-35A22 (BLU)	PR/S	P2	1	*P1	10
APN209-36A22	NO/S	CB	-	SPLICE	SP1
APN209-36B22	NO/S	K100	7	DIMMER	CONTROL
APN209-36C22	NO/S	K100	4	SPLICE	SP1
APN209-36D22	NO/S	K100	5	SPLICE	SP2
APN209-36E22	NO/S	K100	2	SPLICE	SP2
APN209-36F22	NO/S	SPLICE	SP2	SPLICE	SP1
APN209-21A	COAX	P3	ANT	P1501	-
APN209-22A	COAX	P4	ANT	P1501	-
L211D22N	NO/S	P1	5	GND	-
L211E22N	NO/S	GND	-	*P1	18
L212B22	NO/S	P1	10	TB100	8
L215C22	NO/S	TB100	3	*P1	17

1 Underlined Connector Pin Letters Denote Lower Case

2 Denotes: NO/S--No Shield
PR/S--Pair Twisted, W/Shield

* DENOTES P1 ON HEIGHT IND, ID-1917/APN-209

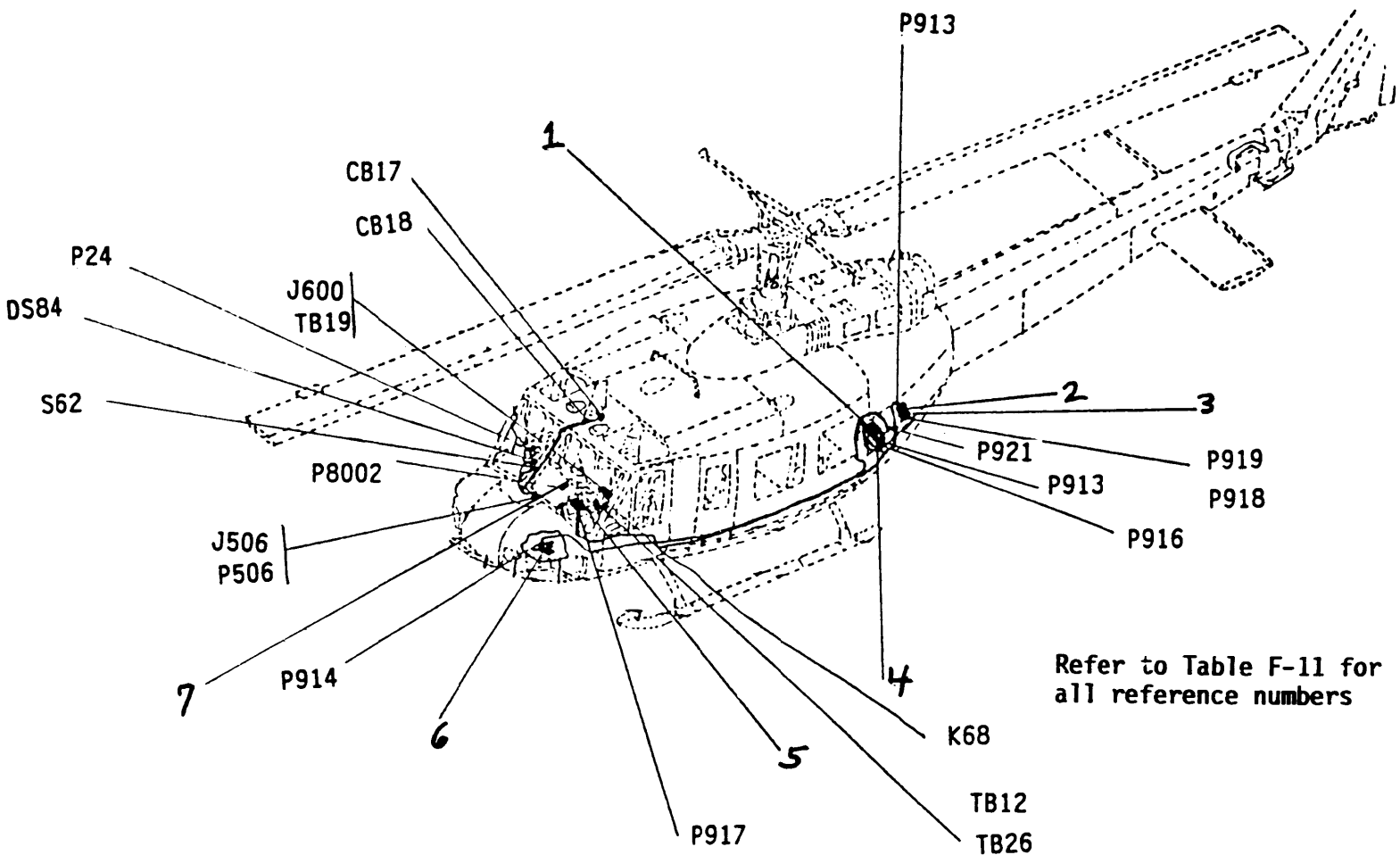

Figure F-11. IFF System AN/APX-72 (Sheet 1 of 2)

<u>DRAWING DESIGNATION</u>	<u>PART NUMBER</u>	<u>DESCRIPTION</u>
1	RT-8590/APX-72	Receiver-Transmitter
2	TS-1843()/APX	Transponder Test Set
3	MT-3513/APx	Mount
4	MT-3809/APX-72	Mount
5	C-6280A(P)/APX	Transponder Control
6	AT-884/APX-44	Antenna
7	AAU-32A	Altimeter

Figure F-11. IFF System AN/APX-72 (Sheet 2 of 2)

Table F-11. IFF System AN/APX-72

WIRE NUMBER	TYPE 2	END 1	PIN 1	END 2	PIN 1
SX45N22	NO/S	P916	3	SPLICE	
SX45P22	NO/S	SPLICE		SPLICE	
SX45R22	NO/S	SPLICE		SPLICE	
SX45S22	NO/S	SPLICE		SPLICE	
SX45T22	NO/S	SPLICE		SPLICE	
SX45U22	NO/S	SPLICE		SPLICE	
SX45V22	NO/S	SPLICE		SPLICE	
SX45W22	NO/S	SPLICE		SPLICE	
SX45X22	NO/S	SPLICE		SPLICE	
SX58L22	NO/S	P917	31	SPLICE	
SX58M22	NO/S	SPLICE		SPLICE	
SX58N22	NO/S	SPLICE		SPLICE	
SX58P22	NO/S	SPLICE		SPLICE	
SX58R22	NO/S	SPLICE		SPLICE	
SX705A20N	NO/S	P917	31	TB26	6
SX705B20N	NO/S	P921	34	TB26	7
SX705C20N	NO/S	TB26	8	SPLICE	
SX705D20N	NO/S	P918	2	TB26	8
SX705E20N	NO/S	TB26	8	SPLICE	
SX705F22N	NO/S	DS84	1	GND	
SX705G22N	NO/S	S62	4	GND	
SX706A18	SHIELD	P916	2	CB17	
SX707A22	SHIELD	P916	4	P917	24
SX712A22	SHIELD	P916	21	P917	2
SX714A22	SHIELD	P916	20	P917	11
SX716A22	SHIELD	P916	19	P917	5
SX717A22	SHIELD	P916	18	P917	6
SX719A22	SHIELD	P916	16	P917	8
SX720A22	SHIELD	P916	15	P917	9
SX721A22	SHIELD	P916	14	P917	10
SX736A20N	NO/S	P917	53	TB26	8
SX743A22	SHIELD	P916	6	P921	31
SX747A20	NO/S	P918	1	CB18	
SX754A22	SHIELD	P916	40	P917	26
SX755A22	SHIELD	P916	39	P917	27
SX755A22N	NO/S	K68	A-2	GND	

Table F-11. IFF System AN/APX-72 (Cont)

WIRE NUMBER	TYPE 2	END 1	PIN 1	END 2	PIN 1
SX756A22	SHIELD	P916	38	P917	28
SX757A22	SHIELD	P916	37	P917	29
SX758A22	SHIELD	P916	36	P917	30
SX761A22	SHIELD	P916	29	P917	32
SX762A22	SHIELD	P916	28	P917	33
SX763A22	SHIELD	P916	27	P917	35
SX764A22	SHIELD	P916	26	P917	36
SX765A22	SHIELD	P916	25	P917	37
SX766A22	SHIELD	P916	24	P917	38
SX766A20	NO/S	K68	A-3	P24	DD
SX768A22	SHIELD	P917	12	TB12	3
SX774A22	NO/S	P918	9	P918	10
SX775B20N	NO/S	K68	X2	GND	-
SX802A22	NO/S	P916	53	P921	28
SX802B22	NO/S	P921	30	K68	X1
SX803A22	SHIELD	P916	9	J600	22
SX804A22N	SHIELD	P916	10	GND	-
SX804B22N	NO/S	SPLICE	-	GND	-
SX806A22	SHIELD	P916	8	P8002	K
SX807A22	SHIELD	P916	54	P8002	J
SX808A22	SHIELD	P916	55	P8002	H
SX809A22	SHIELD	P916	17	P8002	G
SX810A22	SHIELD	P916	23	P8002	F
SX811A22	SHIELD	P916	30	P8002	E
SX812A22	SHIELD	P916	31	P8002	D
SX813A22	SHIELD	P916	32	P8002	C
SX814A22	SHIELD	P916	35	P8002	B
SX815A22	SHIELD	P916	41	P8002	Capped not used
SX816A22	SHIELD	P916	42	P8002	L
SX817A22	SHIELD	P916	59	P917	4
SX818A22	SHIELD	P916	43	P917	15
SX819A22	SHIELD	P916	44	P917	16
SX820A22	SHIELD	P916	50	P917	17
SX821A22	SHIELD	P916	56	P917	18
SX822A22	SHIELD	P916	57	P917	19
SX823A22	SHIELD	P916	58	P917	20
SX824A22	SHIELD	P916	22	P917	25
SX825A22	SHIELD	P916	34	P917	42
SX826A22	SHIELD	P916	51	P917	55
SX828A	SHIELD	P916	45	P921	2
SX829A	SHIELD	P916	46	P921	3
SX830A	SHIELD	P916	47	P921	1
SX831A	SHIELD	P916	48	P921	4
SX832A22	NO/S	P916	52	P921	17
SX833A22	SHIELD	P916	49	GND	-
SX834A20	SHIELD	CB17	12	TB19	1
SX834B20	SHIELD	P917	51	TB19	1
SX834C20	SHIELD	TB19	1	J506	B
SX834D20	NO/S	P506	13	DS84	3

Table F-11. IFF System AN/APX-72 (Cont)

WIRE NUMBER	TYPE 2	END 1	PIN 1	END 2	PIN 1
SX834E20	NO/S	DS84	3	S62	2
SX834F20	NO/S	S62	1	DS84	2
SX836A22	NO/S	P917	45	P918	3
SX837A22	NO/S	P917	40	P918	4
SX838A22	NO/S	P917	41	P918	5
SX839A22	NO/S	P917	43	P918	6
SX840A22	NO/S	P917	44	P918	7
SX841A22	NO/S	P917	46	P918	8
SX847A22	NO/S	P917	32	J506	A
SX847B22	NO/S	P506	A	S62	5
SX848A22	NO/S	P917	1	P921	37
SX849A22	SHIELD	P917	3	P921	19
SX851A22	NO/S	P917	22	P921	33
SX852A22	NO/S	P917	23	P921	14
SX855A22	NO/S	P921	9	P917	48
SX861A22	SHIELD	P917	50	P916	33
SX701A	COAX	P913A	-	P919	-
SX844A	COAX	P913	-	P914	-

1 Underlined Connector Pin Letters Denote Lower Case

2 Denotes: NO/S--No Shield

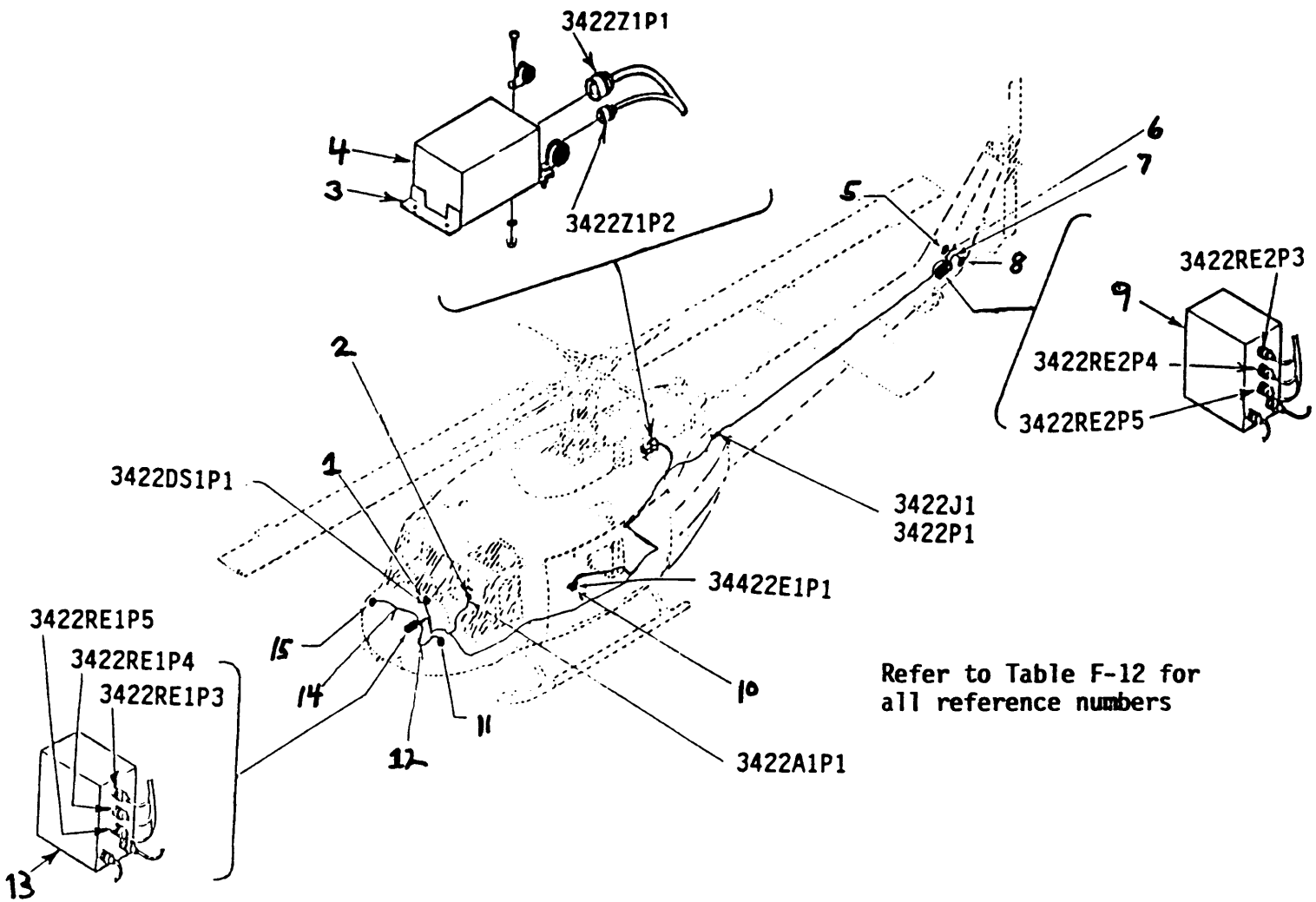

Figure F-12. Radar Warning System AN/APR-39(V) 1 (Sheet 1 of 2)

<u>DRAWING</u> <u>DESIGNATION</u>	<u>PART</u> <u>NUMBER</u>	<u>DESCRIPTION</u>
1	IP-11500/APR-39	Indicator, Radar Signal
2	C-9326/APR-39(V)	Control, Detecting Signal
3	209-077-053-1	Bracket, Support
4	CM440/APR-39(v)	Comparator
5	AS-2891/APR-39(V)	Antenna, Right Spiral
6	209-077-100-5	Cable Assy, Radio
7	209-077-100-7	Cable Assy, Radio
8	AS-2892/APR-39(V)	Antenna, Left Spiral
9	R-1838()/APR-39	Receiver, Radar
10	AS-2890/APR-39(V)	Antenna
11	AS-2891/APR-39(V)	Antenna, Right Spiral
12	209-477-100-11	Cable Assy, Radio
13	R-1838()/APR-39	Receiver, Radar
14	209-477-100-9	Cable Assy, Radio
15	AS-2892/APR-39(V)	Antenna, Left Spiral

Figure F-12. Radar Warning System AN/APR-39(V) 1 (Sheet 2 of 2)

Table F-12. Radar Warning System AN/APR-39(V) 1

WIRE NUMBER	TYPE 2	END 1	PIN 1	END 2	PIN 1
APR39-1A	COAX	3422Z1P1	8	3422RE1P3	J3
APR39-2A	COAX	3422J1	A	3422RE2P3	J3
APR39-2B	COAX	3422P1	A	3422Z1P1	18
APR39-3A	COAX	3422J1	B	3422RE2P4	J4
APR39-3B	COAX	3422P1	B	3422Z1P1	19
APR39-4A	COAX	3422Z1P1	9	3422RE1P4	J4
APR39-11A22	NO/S	3422DS1P1	1	3422Z1P1	1
APR39-12A22	NO/S	3422DS1P1	2	3422Z1P1	2
APR39-13A22	NO/S	3422DS1P1	3	3422Z1P1	3
APR39-14A22	NO/S	3422DS1P1	4	3422Z1P1	4
APR39-15A	COAX	3422DS1P1	5	3422Z1P1	5
APR39-16A22N	NO/S	3422DS1P1	10	3422TB1	1
APR39-17A	COAX	3422Z1P1	7	3422RE1P5	J5
APR39-18A22	NO/S	3422Z1P1	12	3422A1P1	2
APR39-19A22	NO/S	3422Z1P1	13	3422A1P1	3
APR39-20A22	NO/S	3422Z1P1	14	3422A1P1	4
APR39-21A22	NO/S	3422Z1P1	15	3422A1P1	5
APR39-22A22N	NO/S	3422Z1P1	16	GND	-
APR39-23A	COAX	3422J1	C	3422RE2P5	J5
APR39-23B	COAX	3422P1	C	3422Z1P1	17
APR39-24A22	NO/S	3422DS1P1	7	3422A1P1	7
APR39-25A22	NO/S	3422DS1P1	8	3422A1P1	8
APR39-26A22	NO/S	3422DS1P1	9	3422A1P1	9
APR39-27A22N	NO/S	3422TB1	1	3422A1P1	10
APR39-28A22	NO/S	3422A1P1	12	CB1	-
APR39-29A22	NO/S	TB12	3	3422A1P1	13
APR39-30A22	COAX	3422TB1	2	3422A1P1	14

Table F-12. Radar Warning System AN/APR-39 (V) 1 (Cont)

WIRE NUMBER	TYPE 2	END 1	PIN 1	END 2	PIN 1
APR39-31A	COAX	3422Z1P1	21	P916	11
APR39-40A22	NO/S	3422Z1P1	20	GND	SHIELD
APR39-41A20	NO/S	CB1	-	BUS	-
APR39-42A22N	NO/S	3422TB1	1	GND	-
APR39-44A22	COAX	3422TB1	2	P3810	LL
APR39-45A22	COAX	3422TB1	2	P3809	LL
209-077-100-5	COAX	3422RE2	J1	3422E4J1	J1
209-077-100-7	COAX	3422RE2	J2	3422E5J1	J1
209-477-100-9	COAX	3422RE1	J1	3422E2J1	J1
209-477-100-11	COAX	3422RE1	J2	3422E3J1	J1
APR39-8A	COAX	3422Z1P2	J2	34422E1P1	J1
(If C-1611 is used instead of C-6533)					
APR39-29A22	NO/S	3322A1P1	13	TB12	5
APR39-43A22	NO/S	3422TB1	3	TB20	9

1 Underlined Connector Pin Letters Denote Lower Case

2 Denotes: NO/S--No Shield

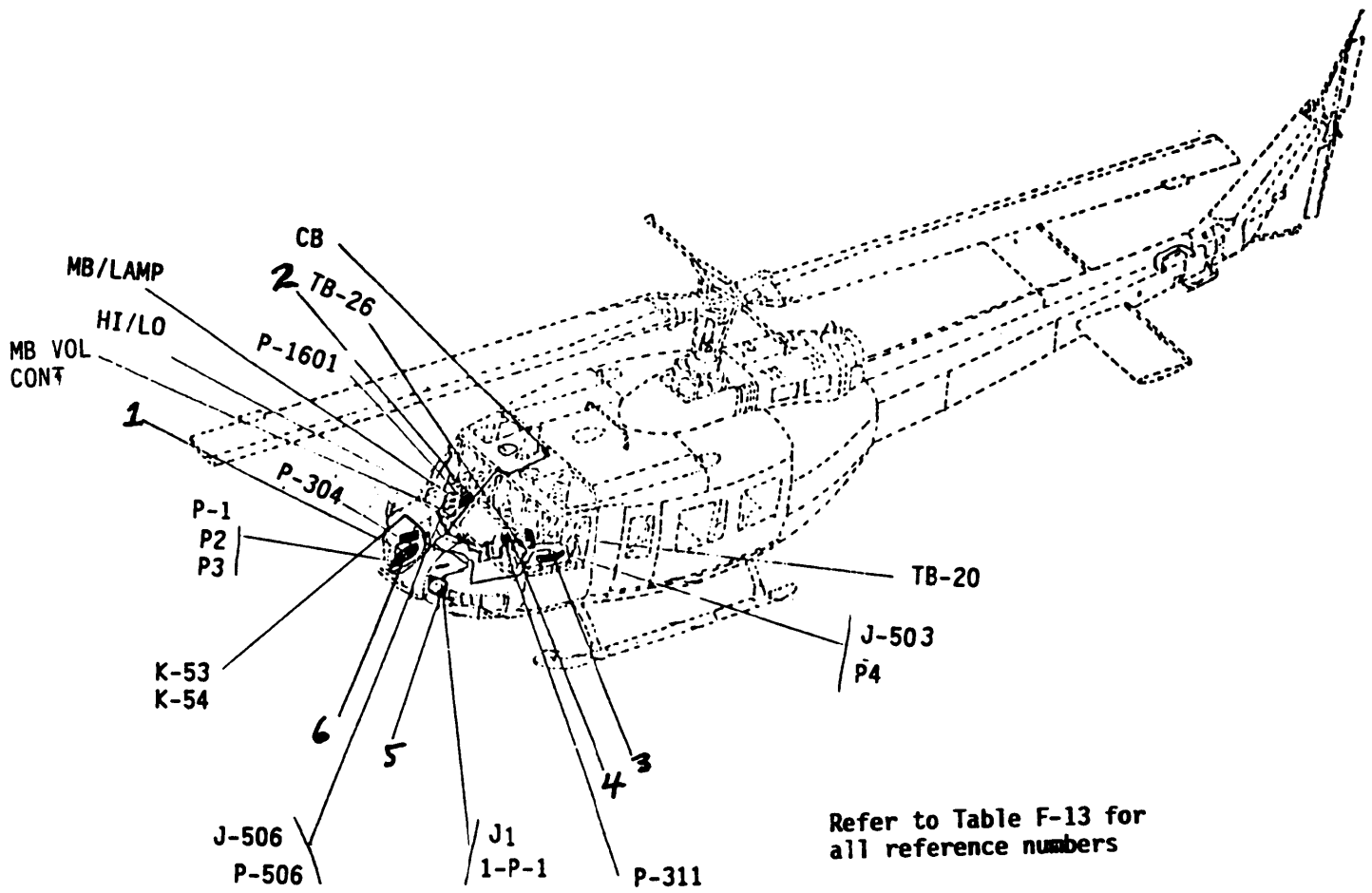

Figure F-13. GS/MB Configuration R-1963/ARN (V) (Sheet 1 of 2)

<u>DRAWING DESIGNATION</u>	<u>PART NUMBER</u>	<u>DESCRIPTION</u>
1	R-1963/ARN	Radio Receiver
2	ID-1347C/ARN-A2	Course Indicator
3	AT-640A/ARN	Antenna
4	C-6873B/ARN-82	Radio Set Control
5	AS-3188/ARN	Antenna
6	MT-4835/ARN	Mount

Figure F-13. GS/MB Configuration R-1963/ARN (V) (Sheet 2 of 2)

WIRE NUMBER	TYPE 2	PLUG	PIN 1	PLUG	PIN 1
R-1963-1A	COAX	P2	-	P4	-
R-1963-2A	COAX	P3	-	1-P-1	-
R-1963-3A22	NO/S	P-1	11	P-311	N
R-1963-4A22	NO/S	P-1	29	P-311	S
R-1963-5A22	NO/S	P-1	12	P-311	H
R-1963-6A22	NO/S	P-1	30	P-311	I
R-1963-7A22	NO/S	P-1	13	P-311	B
R-1963-8A22	NO/S	P-1	31	P-311	I
R-1963-9A22	NO/S	P-1	14	P-311	K
R-1963-10A22	NO/S	P-1	32	P-311	E
R-1963-11A22	NO/S	P-1	15	P-311	I
R-1963-12A22	NO/S	P-1	33	P-311	E
R-1963-13A22	NO/S	P-1	28	P-311	L
R-1963-14A22	NO/S	P-1	34	K-53	K
R-1963-15A22	NO/S	P-1	16	K-53	8
R-1963-16A22	NO/S	P-1	17	K-54	5
R-1963-17A22	NO/S	P-1	35	K-54	17
R-1963-18A22	NO/S	P-1	10	P-311	20
R-1963-19A22	NO/S	P-1	4	SPLICE	J
R-1963-20A20	NO/S	P-311	T	CB	-
R-1963-20B20	NO/S	CB	-	P-1	-
R-1963-21A22	NO/S	P-1	1	J-506	5
R-1963-21B22	NO/S	P-506	S	HI-LO	S
R-1963-22A20N	NO/S	P-1	27	GND	SW
R-1963-23A22	NO/S	P-1	6	J-506	-
R-1963-23B22	NO/S	P506	T	SW	T
R-1963-23C22	NO/S	SW	1	MB/LAMP	2
R-1963-25A22	NO/S	P-1	3	SPLICE	1
R-1963-25B22	NO/S	P-1	20	SPLICE	-
R-1963-25C22	NO/S	SPLICE	-	SPLICE	-
R-1963-25D22	NO/S	P-1	21	SPLICE	-
R-1963-25E22	NO/S	SPLICE	-	J-506	M
R-1963-25F22	NO/S	P-506	M	MB/LAMP	2
R-1963-28A22	PR/S	P-1	7	J-506	P
R-1963-28B22	PR/S	P-506	P	RESISTOR	CW3
R-1963-29A22	PR/S	P-1	8	J-506	C
R-1963-29B22	PR/S	P-506	C	RESISTOR	5

Table F-13. GS/MB Configuration R-1963/ARN (V) (Cont)

WIRE NUMBER	TYPE 2	PLUG	PIN 1	PLUG	PIN 1
R-1963-30A22	PR/S	P-506	R	RESISTOR	4
R-1963-32A22	PR/S	P-506	G	RESISTOR	5
R-1963-32B22	NO/S	J-506	G	TB-26	3
R-1963-34A22	NO/S	P-1	19	GND	SHIELD
R-1963-34B22	NO/S	J-506	N	GND	SHIELD
R-1963-34C22	NO/S	P-506	N	GND	SHIELD
R-1963-34F22N	NO/S	SHIELD	GND	GND	-
RF431B22	NO/S	K-53	4	P-1601	L
RF446B22	NO/S	K-53	7	P-1601	M
RF447C22	NO/S	K-54	19	P-1601	S
RF448C22	NO/S	K-54	16	P-1601	R
RM901D20	NO/S	J-506	R	TB-20	8
RM917A20N	NO/S	HI/LO	SW	GND	-
RM919A20N	NO/S	MB/LAMP	3	GND	-
RN5293A22	NO/S	P-304	1	SPLICE	-
RN5293B22	NO/S	SPLICE	-	P-311	L

1 Underlined Connector Pin Letters Denote Lower Case

2 Denotes: NO/S--No Shield
PR/S--Pair Twisted, W/Shield

GLOSSARY

NOTE

- The terms and acronyms listed herein are defined in relation to BDAR, and accordingly may not be used in the same manner in other manuals.

. Additional definitions of terms, markings, and acronyms used during BDAR assessment procedures will be found under chapter 1, paragraph 1-10, Tagging and Identifying BDAR Repairs.

ABRASION	Roughened surface, varying from light to severe.
ALLOWANCE	A prescribed difference between the maximum condition of mating parts. The minimum clearance or maximum interference between such parts.
API	Armor piercing incendiary armament round.
ASSEMBLY	A group of two or more physically connected and related parts, capable of disassembly, and when combined with other assemblies and parts, creates a component.
ASSEMBLY CLEARANCE	The actual fit between two or more mating parts with respect to the amount of clearance or interference between them.
ASSESSMENT	A procedure to rapidly determine what is damaged, whether it is repairable, what assets are required, who can perform the repair, and where the repair can made.
ASSOCIATED PARTS	A group of parts which could contain one or more unrelated parts of a subassembly, one or more sub-assemblies, and attaching hardware.
AXIAL	Related to an axis. Describes the linear distance a shaft or gear moves.
BATTLEFIELD DAMAGE	Any incident such as combat damage, random failures, operator errors, accidents, and wear-out failures which occur on the battlefield and which prevent the equipment/end item from accomplishing its mission.
BEAM	A primary structural element designed to carry heavy loads by resisting bending in one direction. Usually constructed with a channel, tee, or "I" cross section.
BEND	Any change in an intended configuration.
BORE	Inside measurement of the interior diameter of a hole or tube. Also used to describe the hole itself.

GLOSSARY (Cont)

BOWED	Curved or gradual deviation from original line or plane.
BOX BEAM	A primary structural element designed to carry heavy loads by resisting bending in at least two directions characterized by a square or rectangular hollow cross section.
BRAID	Machine woven wire strands.
BREAK	Separation of a part or substance from itself.
BRIDGING	Jumping or bypassing of a part or component.
BRIELED	Circular indentations on bearing surfaces.
BULKHEAD	The primary vertical structural element. Often called frames or walls.
BUCKLE	Wrinkle or crease damage to sheet metal structural elements.
BURN	Loss of metal resulting from overheating.
BURNISHING	The smoothing of a metal surface by mechanical action without loss of material. Generally found on plain bearing surfaces. Surface discoloration is sometimes present around outer edges of a burnished area.
BURR	A rough edge or sharp projection.
CANNIBALIZATION	The removal of needed parts or assemblies from other aircraft, equipment, or from non-essential systems on the helicopter undergoing repair.
CAP	A continuous structural element (angle, tee, or channel shape) fastened to the top and bottom of a beam or web.
CATASTROPHIC	A sudden and disastrous event caused by equipment failure which endangers human life.
CHAFED	Functional wear. A rubbing action between two parts having relative motion.
CHECK	An examination for verifying.
CHIPPING	Breaking away of small metallic particles.
CHORDLINE	An imaginary line running perpendicular to the leading or trailing edge of a rotor blade.

GLOSSARY (Cont)

CLOCKWISE	A circular motion in the direction the hands of a clock rotate when viewed from the front.
COATING, PROTECTIVE	An external surface treatment, such as paint, anodizing, electroplating or chemical film, used to delay the effects of corrosive or atmospheric elements upon metals.
COMBAT CAPABLE	The ability of the helicopter to perform the MINIMUM combat mission assignments.
COMBAT EMERGENCY CAPABLE	The ability of the helicopter to perform LIMITED specific tactical mission assignments.
COMPONENT	A group of physically connected assemblies or parts.
CONSUMABLE ITEMS	Parts or materials which are consumed by usage or which have a one-time usage in depot maintenance activity.
CORE	The inner layer of material used to construct honeycomb structural panels.
CORROSION	Surface chemical action which results in surface discoloration, a layer of oxide, rust, or removal of surface metal.
COUNTER-CLOCKWISE	The direction opposite to the direction the hands of a clock rotate, when viewed from the front.
CRACK	A break in some type of material.
CRIPPLE	Damage to a load carrying structural member which would cause degradation of the helicopters full mission capability.
CRITERIA	Standards or rules used to judge.
DATA	A group of facts.
DECONTAMINATION	To make an item safe for unprotected personnel by removing, neutralizing, or destroying any harmful substance. A function of Nuclear, Biological, and Chemical (NBC) Warfare.
DENT	Indentation in metal surface produced by an object striking with force.
DISASSEMBLY	The operations necessary to reduce an assembly to its separate components and parts.

GLOSSARY (Cont)

DI STORTI ON	A change from an original shape.
EROSI ON	Wearing away of metal.
EVACUATI ON	A combat service support function which involves the movement of recovered helicopters from a main supply route, maintenance collection point, or maintenance activity to higher categories of maintenance.
EXPEDI ENT	A rapid and often non-standard method of repairing an item (repair technique).
FAI LURE MODE	The specific cause of failure, relating to categories such as cracks, corrosion, ballistic impact, etc.
FATI GUE FAI LURE	Sharp indentations, cracks, tool marks, or inclusions that result in progressive yielding of one or more local areas of material.
FIX	Any rapid action that returns a damaged part or assembly to full or an acceptably degraded operating condition (repair technique).
FLANGE	A broad ridge or pair of ridges projecting from the edge of a structural element, providing additional strength or a place for attachment.
FLAKING	Loose particles of metal or evidence of separation of a surface covering material.
FLUORESCENT PENETRANT	A test for locating cracks and fissures in non-magnetic material, making use of radiation properties of fluorescent particles when exposed to ultraviolet light.
FORMER	A curved structural element which gives the fuselage its even aerodynamic shape. Normally longerons and stringers are attached and the skin is fitted tightly over all these elements.
FRACTURE	Separation of a part or piece of material from itself.
FRAYING	Loose or raveled threads and fibers.
FULLY MISSION CAPABLE (FMC)	The ability of the helicopter to perform ALL its combat mission assignments.
FUNCTIONAL GROUP	Major helicopter subsystems identified in and corresponding to functional groups in TM 55-1520-210-23.
FUSELAGE	The central main body of the helicopter.

GLOSSARY (Cont)

GALLING	Aggravated condition of wear, generally caused by a rubbing action with little or no lubrication.
GAP	Clearance between faying surfaces, measurement of which is used to determine thickness of shims.
GOUGING	Removal of surface metal because of mechanical contact with foreign material.
HEAT DISCOLORATION	A change in color or appearance of a part, caused by excessive temperature.
HEI	High explosive incendiary armament round.
HOUSING	A frame support or cover, used to hold parts of machinery in place. Also used as a protective cover.
INDENTATION	A cavity with smooth bottom or sides, which can occur on rolling contact surfaces.
INSPECTION	A critical examination of parts to determine their usefulness or condition.
INTERFACE	The joining point of two flat surfaces.
JURY-RIGGING	A rapid non-standard method of repairing an item (repair technique).
LIMIT	An established point or boundary, in time, speed, or space, beyond which something may not go or is not permitted to go.
LOAD PATH	The route taken by a mechanical force traveling through an airframe structure.
LONGERON	A principle longitudinal (fore and aft), structural element (angle or tee shape) continuous across several points of support.
LRU	Line replaceable unit (electronic circuit board).
MAINTENANCE COLLECTION POINT	A point operated by AVIM units for the collection of equipment for repair.
MAINTENANCE SUPPORT TEAM (MST)	A team consisting of AVUM and AVIM mechanics and technical specialist who are trained in assessing battle damage in addition to their routine speciality.

GLOSSARY (Cont)

MAINTENANCE TEAM (MT)	A team consisting of organizational mechanics who may be trained in assessing battle damage and field repair procedures.
MISSION FUNCTION COMBAT CAPABLE (MFCC)	The ability of the helicopter to perform the MINIMUM combat mission assignments.
MODIFICATION	An alteration and/or integral change affecting the configuration of equipment or its respective parts, components, subassemblies, or assemblies.
NATIONAL STOCK NUMBER (NSN)	The assigned identifying number for an item of supply, consisting of the four-digit Federal Supply Class (FSC), and the nine-digit National Stock Identification Number (NIIIN).
NICK	A local break or notch in the edge of material.
OPERATION	Performance of a practical, functional action.
OPTION	A specific BDAR repair technique often non-standard in nature.
OVERHAUL	The process of repairing or adjusting a machine to restore, improve, or lengthen its useful life.
PEELING	A breaking away of surface finishes such as coatings or platings, or flaking of large pieces of such material.
PIGTAIL	A group of electrical wire strands twisted together.
PITTING	Small holes or indentations, generally caused by rust, corrosion, high compressive stresses, or metal-to-metal pounding.
PRACTICE	A repeated or customary action.
PRIMARY STRUCTURE	The major structural load carrying elements of an airframe without which helicopter flight safety would be compromised.
PROCEDURE	A particular course of action.
PROCESS	A series of actions conducive to an end.
PYLON	The box shaped structural area surrounding the helicopter main transmission. This area carries several primary structural loads.

GLOSSARY (cont)

REASSEMBLY	The assembling and allgning of all subassemblies and parts into a complete assembly to affect a serviceable Item of equipment.
RECOVERY	The retrival of immobile, Inoperative, or abandoned helicopters from the battlefield or immediate vicinity and its movement to a maintenance collection point, main supply route, or a maintenance activity for disposition, repair, or evacuation.
REMOVE	To move by lifting, pulling or pushing.
REPAIR	To restore a defective part, component, subassembly, or assembly to a usable condition in accordance with the instructions contained in this manual.
REPLACE	To supply an equivalent for.
REWORK	To work over again.
RUPTUR\qE	The breaking of an airframe structural element or skin due to overstress/hostile fire.
SCORING	Very deep scratches caused by foreign particles between surfaces that are moving, or between one moving and one stationary surface. Scores follow the travel direction of the part.
SCRATCHING	Narrow, shallow lines resulting from movement of foreign particles across a surface.
SECONDARY STRUCTURE	The non-flight safety structural elements of an airframe.
SELF-RECOVERY	The ability of the helicopter to fly at reduced airspeed and altitude from the battlefield or immediate vicinity to a maintenance collection point, the main supply route, or maintenance activity for disposition, repair or evacuation.
SEMIMONOC	A structural design which relies on strength of the skin to carry a large portion of the load. The skin Is normally reinforced by longerons and vertical bulkheads (walls), but has no diagonal bracing, leaving the interior basicly hollow.
SERVICING	The lubrication, treating, cleaning, or preservation necessary to maintain the equipment and other respective parts in serviceable condition.
SKIN	The aerodynamic exterior covering of the helicopter.

GLOSSARY (Cont)

SPALLING	Chipped or flaked surface caused by the breaking away of the hardened metal and separation of the case from the core.
SPANWISE	The location of a point or direction of movement parallel to the leading or trailing edge of a rotor blade.
SPAR	A primary structural element designed to carry weight and resist bending loads in wings and rotor blades. Spars typically extend the full length of the wing, and taper down to a smaller cross section toward the tip of the wing.
STIFFENER	A longitudinal (fore and aft) structural element used in semi-monocoque design which stiffens the skin. Often called a stringer.
STOP HOLE	A hole intentionally drilled at the end of a crack, or saw cut which normally will prevent further propagation of the crack.
STRINGER	A longitudinal (fore and aft) structural element used in semi-monocoque design which stiffens the skin. Often called a stiffener.
TEST	As used herein, the checking or operation of equipment to determine that the unit functions properly within the limits set forth in this manual.
TOLERANCE	The difference between two limiting sizes as a means of specifying the degree of accuracy.
TOXIC	A poisonous substance.
TWIST	The damage of a structural element by turning or torque forces causing permanent deformation.
VISCOSITY	The property of a fluid that tends to resist the force trying to make it flow such as gravity or applied pressure.
WARPAGE	The bending or twisting damage causing a structural element to weaken and permanently lose its original shape.
WEB	The sheet metal membrane connecting the upper and lower flanges of a beam or spar. Provides overall rigidity to the airframe structure.
WHIP	The tendency of a bent shaft to rotate away from its original center as the shaft RPM is increased, thus causing severe vibration.

INDEX

Subject

Paragraph

A

Accessory Gearbox and Fuel Control Assembly, Minor Leaks	6-7
Armament-Hydraulic System, Leaking	9-17
Antenna, Substitute Emergency.	11-26
Assessment Procedures	
Alighting Gear	5-2
Airframe.	4-1
Drive Train Systems	8-2
Electrical and Avionics System	11-2
Flight Controls	13-2
Instruments	10-2
Fuel System	12-2
General Repairs.	3-2
Helicopter Flight.	2-2
Hydraulic and Pneumatic Systems	9-2
Power Plant.	6-2
Rotors.	7-2

B

Battery Bus Bar Repair	11-23
Bleed Air Fittings, Damaged.	9-24
Bleed Air Line Leaking - Plug or Isolate	9-22
Bleed (Flex Tube) Air Line 3/4 & 1 Inch to Oil Cooler Fan Leak.	9-23
Broken Fuses.	11-21
Bulkhead and Former Frames, Major Damage	3-11
Bulkhead and Former Frames, Minor Damage	3-12

C

Characteristics	
BDAR.	1-5
Operating.	1-7
Check Valves, Leaking.	9-15
Circuit Protection Device Repair	11-20
Coax Splice	11-14, 11-15
	11-16, 11-17
Component Bridging	11-18
Connecting Links, Damaged in Center.	13-5
Connector Pins, Damaged.	11-19
Control Cable, Damaged (Splice Repair)	13-13

D

Definitions.	1-4
----------------------	-----

INDEX (Cont)

Subject	Paragraph
E	
Elevator, Inoperable.	13-11
External Oil Filter Leak.	8-8
F	
Fabrication of Bellcranks and Levers	13-9
Fabrication of Lever Assembly.	13-7
Fuel Filter Assembly, Damaged and Leaking.	12-10
Fuel Cell, Damaged Beyond Repair.	12-8
Fuel Cell, Leaking, Damaged Up to 3 X 1 Inch Area.	12-9
Functional List and Assignment of Flight Essential Instruments	10-4
G	
Gearboxes, Small Leaks through Case and Cracks	8-13
H	
Honeycomb Panels, Damaged 2 Inch Max Dia	3-14
Honeycomb Panels, Damaged 2 to 8 Inches in Dia.	3-15
Honeycomb Panels, Damaged Up to 12 X 12 Inches Through Panel	3-16
Hydraulic Filter, Damage and Leaking	9-7
I	
J	
K	
L	
Longerons and Caps, Severed.	3-9
Low Pressure Hoses and Metal Tubing, Leaking	3-18
M	
Main Rotor Blade, Damage Holes of 1 Inch Dia or Less	7-5
Main Transmission Cases, Leak Through Small Holes and Cracks in Case Walls.	8-5
Metal Tube Leaking/Damaged	9-20
Metal Tubing, Damage.	12-5

INDEX (Cont)

Subject	Paragraph
N	
Nose Section, Bottom Window Cracks and Holes	4-6
Nose Section, Damage to External Structures or Skin.	4-5
O	
Oil Filter Leak, External.	8-8
Oil Tank, Leaking.	6-5
Oil Pressure Indicator or Transmitter, Damaged/Bad Reading	10-6
P	
Pitot Plenum, Damaged.	10-8
Pitot Static System.	10-7
Power Bus Bar Repair	11-22
Power Relay Test and Repair.	11-24
Pressure Switch, Damaged and Leaking	9-13
Q	
R	
Relief Valve, Leaking Hydraulic Fluid.	9-9
Reservoir, Leaking Hydraulics Fluid.	9-5
Rubber Hose, Damaged	12-6
Repair Procedure Index	
Alighting Gear	5-3
Airframe.	4-3
Drive Train System	8-3
Electrical and Avionics System	11-3
Flight Controls	13-3
Instruments	10-3
Fuel System	12-3
General Repairs.	3-3
Hydraulic and Pneumatic Systems	9-3
Power Plant	6-3
Rotors.	7-3

INDEX (Cont)

Subject	Paragraph
S	
Shield Terminators	11-10
Shielded Cable Repair	11-8
Shielded Cable Repair Segments	11-9
Skid Tubes, Damage to Area A and E of Figure 5-2	5-5
Skid Tubes, Damage to Area B of Figure 5-2	5-7
Skid Tubes, Damage to Area C and D of Figure 5-2	5-6
Skin and Structural Damage, General.	4-5
Skin Damage.	3-5
Solenoid Valve, Damaged and Leaking.	9-11
Static Manifold, Damaged	10-6
Stiffeners and Stringers, Damaged.	3-7
T	
Tagging/Identifying BDAR Repairs	1-9
Tail Rotor Driveshaft Sections, Minor Damage	8-10
Tail Rotor Driveshaft Sections, Moderate Damage.	8-11
Terminal Boards	11-12
Terminal Lugs.	11-13
Terminators for Nickel-Plated Shields (Including Vermilion)	11-11
Training.	1-8
Transmission Oil Pressure Switch Leak.	8-6
Transmission Oil Pressure Transmitter Leak.	8-7
U	
Unshielded Wires, Damaged.	11-5
V	
W	
Waiver of Precautions.	1-6
Wire Insulation, Damaged	11-7
Wire Repair Segments; Unshielded Wires	11-6

XYZ

By Order of the Secretary of the Army:

CARL E. VUONO
General, *United States Army*
Chief of Staff

Official:

THOMAS F. SIKORA
Brigadier General United States Army
The Adjutant General

DISTRIBUTION:

To be distributed in accordance with DA Form 12-31-R, AVUM and AVIM Maintenance requirements for UH-1H and UH-1V Helicopter, Utility.

