

Sight Gage Glass Pullers

Oil sight gage glasses must be removed for cleaning and inspection of internal gear wear patterns. Some mechs grab for the nearest screwdriver or pliers to pry the glass off. The result is usually damaged or broken glass.

But you can make a tool to remove the glass without scratching or breaking it. Take your choice: Tool No. 1 was submitted by Jesse Witters of Grand Canyon Helicopters, AZ, and appeared in PS 332. Tool No. 2 was submitted by SGT Jerold L. Fry and appeared in PS 363.

Tool No. 1 Get a 6-in piece of 1 inch diameter aluminum tubing and cut four slots 1 1/2 inches deep in one end. Slide a hose clamp over the slotted end of the tube.

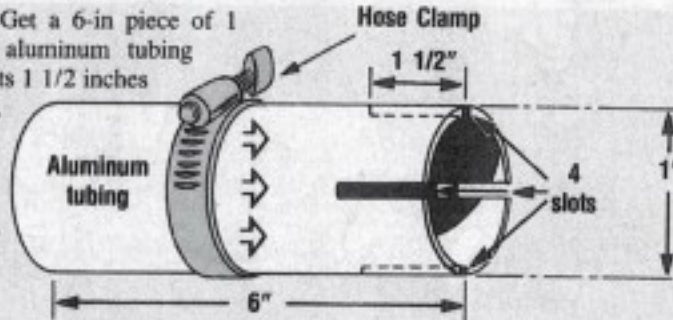

To use the tool, remove the lock ring from the sight glass. Slip the tool over the glass and tighten the clamp. A slight pull removes the glass from the gage.

Tool No. 2 Get your AVIM shop to make this tool from solid 1 1/2 inch diameter aluminum stock. Just slip it over the sight glass, tighten the wing nut, and pull.

