

TM 55-1520-242-S

TECHNICAL MANUAL

**PREPARATION FOR SHIPMENT
OF
UH-1/EH-1 HELICOPTERS**

**This copy is a reprint which includes current
pages from Changes 1 through 4.**

This manual supersedes TM 55-1500-219-S, 7 January 77, including all changes.

HEADQUARTERS, DEPARTMENT OF THE ARMY

20 JANUARY 1981

The Metric System and Equivalent

Linear Measure

1 centimeter = 10 millimeters = .39 inch
 1 decimeter = 10 centimeters = 3.94 inches
 1 meter = 10 decimeters = 39.37 inches
 1 dekameter = 10 meters = 32.8 feet
 1 hectometer = 10 dekameters = 328.08 feet
 1 kilometer = 10 hectometers = 3,280.8 feet

Weights

1 centigram = 10 milligrams = .15 grain
 1 decigram = 10 centigrams = 1.54 grains
 1 gram = 10 decigram = .035 ounce
 1 dekagram = 10 grams = .35 ounce
 1 hectogram = 10 dekagrams = 3.52 ounces
 1 kilogram = 10 hectograms = 2.2 pounds
 1 quintal = 100 kilograms = 220.46 pounds
 1 metric ton = 10 quintals = 1.1 short tons

Liquid Measure

1 centiliter = 10 milliliters = .34 fl. ounce
 1 deciliter = 10 centiliter = 3.38 fl. ounces
 1 liter = 10 deciliters = 33.81 fl. ounces
 1 dekalitar = 10 liters = 2.64 gallons
 1 hectoliter = 10 dekaliters = 26.42 gallons
 1 kiloliter = 10 hectoliters = 264.18 gallons

Square Measure

1 sq. centimeter = 100 sq. millimeters = .155 sq. inch
 1 sq. decimeter = 100 sq. centimeters = 15.5 sq. inches
 1 sq. meter (centare) = 100 sq. dacineters = 10.76 sq. feet
 1 sq. dekameter (are) = 100 sq. meters = 1,076.4 sq. feet
 1 sq. hectometer (hectare) = 100 q. dekameters = 2.47 acres
 1 sq. kilometer = 100 sq. hectometers = .386 sq. mile

Cubic Measure

1 cu. centimeter = 1000 cu. millimeters = .06 cu. inch
 1 cu. decimeter = 1000 cu. centimeters = 61.02 cu. inches
 1 cu. meter = 1000 cu. decimeters = 35.31 cu. feet

Approximate Conversion Factors

<i>To change</i>	<i>To</i>	<i>Multiply by</i>	<i>To change</i>	<i>To</i>	<i>Multiply by</i>
inches	centimeters	2.540	ounce-inches	newton-meters	.007082
feet	meters	.305	centimeters	inches	.394
yards	meters	.914	meters	feet	3.280
miles	kilometers	1.609	meters	yards	1.084
square inches	square centimeters	6.451	kilometers	miles	.621
square feet	square meters	.093	square centimeters	square inches	.165
square yards	square meters	.836	square meters	square feet	10.764
square miles	square kilometers	2.580	square meters	square yards	1.186
acres	square hectometers	.405	square kilometers	square miles	.386
cubic feet	cubic meters	.028	square hectometers	acres	2.471
cubic yards	cubic meters	.765	cubic meters	cubic feet	35.315
fluid ounces	milliliters	29.573	cubic meters	cubic yards	1.308
pints	liters	.473	milliliters	fluid ounces	.034
quarts	liters	.946	liters	pints	2.113
gallons	liters	3.785	liters	quarts	1.057
ounces	grams	28.349	liters	gallons	.264
pounds	kilograms	.454	grams	ounces	.035
short tons	metric/tons	.907	kilograms	pounds	2.205
pound-feet	newton-meters	1.365	metric tons	short tons	1.102
pound-inches	newton-meters	.11375			

Temperature (Exact)

°F Fahrenheit
temperature

5/9 (after
subtracting 32)

Celsius
temperature

°C

URGENT

TM 55-1520-20-242-S

C 5

CHANGE

HEADQUARTERS

DEPARTMENT OF THE ARMY

WASHINGTON, D.C., 30 June 1993

NO. 5

PREPARATION FOR SHIPMENT
OF
UH-1/EH-1 HELICOPTERS

DISTRIBUTION STATEMENT A: Approved for public release; distribution is unlimited

TM 55-1520-242-S, 20 January 1981, is changed as follows:

1. Remove and insert pages as indicated below. New or changed text material is indicated by a vertical bar in the margin. An illustration change is indicated by a miniature pointing hand.

Remove pages

Insert pages

2-19 and 2-20

2-19 and 2-20

3-3 and 3-4

3-3 and 3-4

2. Retain this sheet in front of manual for reference purposes.

By Order of the Secretary of the Army:

Official:

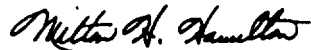

MILTON H. HAMILTON

*Administrative Assistant to the
Secretary of the Army*

03955

GORDON R. SULLIVAN
*General, United States Army
Chief of Staff*

DISTRIBUTION:

To be distributed in accordance with DA Form 12-31-E, block no. 0697, requirements for TM 55-1520-242-S

URGENT

CHANGE }
 NO. 4 }

HEADQUARTERS
 DEPARTMENT OF THE ARMY
 WASHINGTON, D.C., 18 December 1990

PREPARATION FOR SHIPMENT
 OF
 UH-1/EH-1 HELICOPTERS

TM 55-1520-242-S, 20 January 1981, is changed as follows:

1. Remove and insert pages as indicated below. New or changed text material is indicated by a vertical bar in the margin. An illustration change is indicated by a mirtiature pointing hand.

Remove Pages	Insert Pages
i through iii/iv	i through iii/iv
1-1 and 1-2	1-1 and 1-2
2-3 and 2-4	2-3 and 2-4
2-11 and 2-12	2-11 and 2-12
2-16	2-16
2-21 and 2-22	2-21 and 2-22
- - - - -	2-22.1 and 2-22.2
- - - - -	2-25/2-26
3-1 through 3-3/3-4	3-1 through 3-3/3-4
6-1 and 6-2	6-1 and 6-2
7-1 through 7-4	7-1 through 7-4
7-9 through 7-12	7-9 through 7-12
- - - - -	7-12.1 and 7-12.2
A-1/A-2	A-1/A-2
D-3/D-4	D-3/D-4
G-1 and G-2	G-1 through G-8
H-1 and H-2	H-1 and H-2
J-1 and J-2	J-1 and J-2
2028's and Envelopes	2028's and Envelopes

2. Retain this sheet in front of manual for reference purposes.

By Order of the Secretary of the Army:

CARL E. VUONO
General, United States Army
Chief of Staff

official:

THOMAS F. SIKORA
Brigadier General United States Army
The Adjutant Geneml

DISTRIBUTION:

To be distributed in accordance with DA Form 12-31, AVUM and AVIM Maintenance requirements for All UH-1 series Aircraft, EH-1H Helicopter, Electronic, Countermeasure and EH-1X Helicopter, Electronic Countermeasure & Intercept.

CHANGE }
NO. 3 }

HEADQUARTERS
DEPARTMENT OF THE ARMY
WASHINGTON, D.C., 10 February 1987

PREPARATION FOR SHIPMENT
OF
UH-1/EH-1 HELICOPTERS

TM 55-1520-242-S, 20 January 1981, is changed as follows:

1. Remove and insert pages as indicated below. New or changed text material is indicated by a vertical bar in the margin. An illustration change is indicated by a miniature pointing hand.

Remove pages

i through iii/iv
1-1 and 1-2
- - -
-- -
2-3 through 2-6
-- -
2-7 through 2-14
3-1 through 3-3/3-4
4-1 and 4-2
5-1/5-2
6-1 and 6-2
-- -
6-3 and 6-4
6-9 and 6-10
7-11 and 7-12
A-1/A-2
B-5/B-6
C-1 and C-2
D-3/D-4
E-1/E-2
- - -

Insert pages

i through iii/iv
1-1 and 1-2
1-2.1/1-2.2
1-5/1-6
2-3 through 2-6
2-6.1/2-6.2
2-7 through 2-14
3-1 through 3-3/3-4
4-1 and 4-2
5-1/5-2
6-1 and 6-2
6-2.1/6-2.2
6-3 and 6-4
6-9 and 6-10
7-11 and 7-12
A-1/A-2
B-5/B-6
C-1 and C-2
D-3/D-4
E-1/E-2
J-1 through J-4

2. Retain these sheets in front of manual for reference purposes.

TM 55-1520-242-S
C 3

By Order of the Secretary of the Army:

JOHN A. WICKHAM, JR.
General, United States Army
Chief of Staff

Official:

R. L. DILWORTH
Brigadier General, United States Army
The Adjutant General

DISTRIBUTION:

To be distributed in accordance with DA Form 12-31, AVUM and AVIM Maintenance requirements for All UH-1 series Aircraft, EH-1H Helicopter, Electronic, Countermeasure and EH-1X Helicopter, Electronic Countermeasure & Intercept.

CHANGE }
 NO. 2 }

HEADQUARTERS
 DEPARTMENT OF THE ARMY
 WASHINGTON, D.C., 15 April 1983

PREPARATION FOR SHIPMENT
 OF
 UH-1/EH-1 HELICOPTERS

TM 55-1520-242-S, 20 January 1981, is changed as follows:

1. Remove and insert pages as indicated below.

	Remove pages	Insert pages
Chapter 2	2-17 and 2-18	2-17 and 2-18
Chapter 4	4-1 and 4-2	4-1 and 4-2
Appendix D	D-3/D-4	D-3/D-4

2. New or changed text material is indicated by a vertical bar in the margin. An illustration change is indicated by a miniature pointing hand.

3. Retain this sheet in front of manual for reference purposes.

By Order of the Secretary of the Army:

E.C.MEYER
General, United States Army
Chief of Staff

Official:

ROBERT M. JOYCE
Major General, United States Army
The Adjutant General

DISTRIBUTION:

To be distributed in accordance with DA Form 12-31, Organizational Maintenance Requirements for UH-1B, UH-1C\M, UH-1D/H and EH-1H aircraft .

CHANGE

No. 1

HEADQUARTERS
DEPARTMENT OF THE ARMY
WASHINGTON, D.C., 19 January 1982

PREPARATION FOR SHIPMENT
OF
UH-1/EH-1 HELICOPTERS

TM 55-1520-242-S, 20 January 1981, is changed as follows:

1. Remove and insert pages as indicated below:

	Remove pages	Insert pages
Warning	c/d	c/d
Table of contents	i thru iii /iv	i thru iii/iv
Chapter 1	1-1 and 1-2	1-1 and 1-2
Chapter 2	2-1 thru 2-4 2-7 and 2-8 2-13 thru 2-20	2-1 thru 2-4 2-7 and 2-8 2-13 and 2-14 2-16 thru 2-20
Chapter 6	6-1 thru 6-8	6-1 thru 6-8
Chapter 7	7-1 thru 7-4 7-7 thru 7-10	7-1 thru 7-4 7-7 thru 7-10
Appendix D	D-1 thru D-3/D-4	D-1 thru D-3/D-4
Appendix E	E-1/E-2	E-1/E-2
Appendix G	G-1 and G-2	G-1 and G-2
Appendix H	H-1 thru H-3/H4 FO-1 FO-2	H-1 thru H-3/H-4 FO-1 FO-2

2. New or changed text material is indicated by a vertical bar in the margin. An illustration change is indicated by a miniature pointing hand.

3. Retain this sheet in front of manual for reference purposes.

By Order of the Secretary of the Army:

E. C. MEYER
General, United States Army
Chief of Staff

Official:

ROBERT M. JOYCE
Brigadier General, United States Army
The Adjutant General

DISTRIBUTION:

To be distributed in accordance with DA Form 12-31, Organizational Maintenance Requirements for UH-1B, UH-1C/M, UH-1D/H and EH-1H aircraft.

WARNING

- . Helicopter gross weight should not exceed 6,300 pounds when using the single wheel modification kit. Therefore, do not carry fuel causing the helicopter to exceed this weight.
- . TM 38-250 requires that all helicopters with purged fuel systems be tested for dangerous fuel vapors immediately prior to loading in cargo aircraft. Test with a combustible gas indicator. If a dangerous level exists, repurge fuel System until a safe reading is obtained. To avoid emergency purging, check fuel system periodically prior to loading.
- . Computation of center of gravity (CG) must be exact. Using predetermined CG or estimated weights may cause aircraft instability, jeopardizing cargo and crew.
- . Stand clear of modified ground handling wheels while loading: bolts have broken, injuring loading personnel.
- . Trichlorotrifluoroethane is safe and non-flammable, use only with adequate ventilation. Avoid prolonged breathing of vapors. Do not use near open flames or heat, since its decomposition products are toxic. Wear rubber gloves and avoid contact with skin.
- . To ensure personnel and equipment safety, observe the following precautions: Properly ground aircraft and all equipment used, including defueling equipment, work stands, purging equipment, and powered or pneumatic tools. Equip work stands with a personnel static discharge plate of copper or zinc plate so that personnel can contact plate before contacting aircraft. Do not drain fuel tanks near the end of the work day and allow to stand "empty" overnight. Residue fuel drains down tank sides, forming puddles. During the night, fuel from these puddles evaporates into the air. If a critical fuel-air ratio develops, a spark could set off an explosion. Therefore, avoid a time lapse between draining and purging.
- . Keep electrolyte from contacting clothing, skin, or eyes.
- . Turn battery switch on panel OFF prior to working on battery.

WARNING

- Wear rubber gloves, protective clothing and respirators as recommended by post surgeon or safety officer when placing or removing rodenticide bait blocks .

CAUTION

- With tailboom overhead, helicopter is nose heavy: with tailboom side mounted, helicopter is both nose and left side heavy. Either fixture makes the UH-1 hard to steer and difficult to move up and down ramps.
- If spoilers are mounted on upper surfaces of synchronized elevators (UH-1B), pack elevators so that spoilers are adjacent to exterior surfaces of packing box.
- Carry at least one set of ground handling wheels, if used, in the cargo aircraft to ensure their availability at the unloading site. If the tailboom is removed and dolly wheels installed under forward cross tubes, carry a set of dolly wheels as well. Check tires for proper inflation.
- Do not abuse ground handling wheels particularly the single wheel configuration by running over such things as 2x4 or planks. This is likely to blow out tires or strain parts of handling wheel supports. When ramp extensions are made of nominal two-inch lumber, reduce the bump at the ends by adding small pieces of wood or cutting the ends to make a gradual slope. This also applies to shoring used on cargo aircraft floor to prevent damage from dolly wheels.
- Use shoring to make a smooth grade from cargo aircraft ramp to ground. Obstacles and rough terrain can impede small wheels, resulting in dolly tongue rotating to strike helicopter fuselage.
- As modified ground handling wheels approach ramp hinge, place metal strips or plywood under skid tubes and dolly wheels to prevent damage to cargo floor.

CAUTION

Take care when stowing rotor blades not to damage blade tips, drain tubes, or navigation lights. Top of blades shall be placed to prevent damage by personnel walking on them.

There must be at least three inches of clearance between helicopters.

- Ensure that tiedown chains do not contact thin helicopter skin. Tighten chains one-hand tight to prevent over-stressing helicopter skin.
- Do not put too much tension on straps attached to helicopter tailboom. Due to the long lever arm, a slight stress is multiplied to the point of structural damage to helicopter.
- No gouges or deep scratches on any part of landing gear can be tolerated. Use of chains or wire rope without adequate protection would ruin landing gear.
- Do not use compounds containing any abrasive material, or solutions containing esters, ketones, aromatic hydrocarbons or chlorinated carbons. Avoid excessive scrubbing of plastic panels.
- Do not exceed maximum operating limitations for engine ground runup.
- Do not operate starter in excess of operating limits: three runs of 40 seconds each, maximum during any 60 minute period. Three minutes cooling time between starts is required. Do not engage starter until engine comes to complete stop.
- UH-1 helicopters mounted on a side-saddle kit are extremely nose heavy. Exercise extreme care in hoisting to avoid damage to helicopter nose.
- When using troops to counterbalance noseheavy UH-1, only two men can stand on top of cabin and on designated step on tailboom fixture. Never apply pressure to any other portion of fixture or an excessive torque will be applied to fuselage at tailboom junction area.

**PREPARATION FOR SHIPMENT
 OF
 UH-1/EH-1 HELICOPTERS**

REPORTING ERRORS AND RECOMMENDING IMPROVEMENTS

You can help improve this manual. If you find any mistake or if you know of a way to improve the procedures, please let us know. Mail your letter, DA Form 2028 (Recommended Changes to Publications and Blank Forms), or DA Form 2028-2 located in the back of this manual direct to: Commander, U.S. Army Aviation Systems Command, ATTN: AMSAV-MC, 4300 Goodfellow Boulevard, St. Louis, MO 63120-1798. A reply will be furnished directly to you.

TABLE OF CONTENTS

		Paragraph	Page
CHAPTER 1.	INTRODUCTION		
Section	I. Purpose	1-1	1-1
	II. General	1-2	1-1
	III. Preservation Checksheets	1-8	1-4
	IV. Depreservation Checksheets	1-9	1-4
CHAPTER 2.	SHIPMENT BY CARGO AIRCRAFT		
Section	I. General	2-1	2-1
	II. Capacities of Cargo Aircraft	2-2	2-1
	III. Preparing the Helicopter	2-5	2-4
	IV. Functions of Cargo Aircraft Crew	2-10	2-10
	V. Functions of Army Loading Team	2-12	2-10
	VI. Preparing the Cargo Aircraft	2-14	2-11
	VII. Loading	2-15	2-12
	VIII. Tiedown	2-18	2-22
	IX. Offloading	2-19	2-23
CHAPTER 3.	SHIPMENT BY VESSEL		
Section	I. Responsibilities	3-1	3-1
	II. Preparing the Aircraft	3-3	3-1
	III. Loading	3-7	3-2
	IV. Tiedown	3-8	3-3
	V. Care during Shipment	3-9	3-3
CHAPTER 4.	SHIPMENT BY TRUCK OR RAIL		
Section	I. General	4-1	4-1
	II. Preparation	4-3	4-1

TABLE OF CONTENTS (Continued)

		Paragraph	Page
CHAPTER 5	CRATED SHIPMENT		5-1
CHAPTER 6	TACTICAL SHIPMENT OF UH-1/EH-1		
Section	I. General		6-1
	II. Military Cargo Planes	6-1	6-1
	III. Functions of Cargo Aircraft Crew	6-4	6-1
	IV. Functions of Army Loading Team	6-7	6-2
	V. Preparing the Cargo Aircraft	6-9	6-3
	VI. Loading	6-10	6-3
	VII. Tiedown	6-14	6-10
	VIII. Offloading	6-15	6-10
	IX. Barge Shipment	6-18	6-12
CHAPTER 7	PREPARATION FOR SHIPMENT		
Section	I. Cleaning	7-1	7-1
	II. Preservation and Packaging	7-7	7-2
	III. Marking	7-22	7-13
	IV. Dangerous and Hazardous Materials	7-25	7-13
APPENDIX			
	A. Reference		A-1
	B. Preservation Checksheets		B-1
	C. Depreservation Checksheets.		C-1
	D. Consumable Materials		D-1
	E. Special Tools and Equipment		E-1
	F. Quarantine Inspection		F-1
	G. Heat Shrink Film Helicopter Protective Covering		G-1
	H. Side-Saddle Kit		H-1
	J. Piggy-Back Kit		J-1

LIST OF ILLUSTRATIONS

Figure	Title	Page
1-1	UH-1/H/V/EH-1 Dimensions.	1-2
1-2	UH-1B Dimensions	1-3
1-3	EH-IX Helicopter Configuration	1-3.1
2-1	Piggyback Configuration	2-4
2-2	Tiedown Support Beans	2-6
2-3	Nose Antenna on EH-1H	2-7
2-4	Rotor Hub Securement	2-8
2-5	C-141 Cargo Aircraft Ramp Extension	2-12
2-6	Application of Ground Handling and Dolly Wheels	2-13
2-9	Modified Ground Handling Wheels	2-17
2-10	Tiedown Diagram for a UH-1/EH-1 in a Cargo Aircraft	2-19
211	C5 Ramp Extensions	2-21
2-11.1	MB-1 ChainWinching Bridle Attached to Helicopter forWhching	2-11.1
2-11.2	Positioning Block	2-11.2
4-2	Shipment of UH-1 Helicopters by Truck	4-3
6-1	C-141 Cargo Aircraft Loading Diagram	6-6
6-2	Loading Sequence and Tiedown Diagram for Six UH-1H/M/V Helicopters in a LASH Lighter	6-13

LIST OF ILLUSTRATIONS (Continued)

Figure	Title	Page
6-3	Loading Sequence and Tiedown Diagram for Nine UH- 1H/M/V Helicopters in a SEABEE Barge	6-14
7-1	Leek-BlocksforUH-1B/C/H/M/Vand EH-1H	7-8
FO-1	C-5 Loading Diagram	FO-1
FO-2	Side-Saddle Kit Installed on UH-1H/V and EH-1	FO-3
FO-3	Stabilizer Bar Support	FO-5
FO-4	Main Rotor Blade Crate	FO-7
FO-5	Shackle Adapter	FO-9
FO-6	Stabilizer Bar Box	FO-11

LIST OF TABLES

Table	Title	Page
2-1	Disassembly of SeriesUH-1B/C/M Helicopters for cargo Airplane Shipment	2-2
2-2	Disassembly of SeriesUH-1H/V, EH-1H Helicopter for Cargo Airplane Shipment	2-3
G-1	Materials and Equipment List..	G-9
G-2	Safety Checklist	G-10

CHAPTER 1

INTRODUCTION

SECTION 1. PURPOSE

1-1. PURPOSE.

This manual prescribes methods and procedures for preparing UH - 1 helicopters for CON US and oversea shipments. Unless specifically stated, it applies equally to UH-1B/C/H/M and V series plus the EH-1H. Handle all classified materials in accordance with local procedures.

SECTION II. GENERAL

1-2. FLIGHT DELIVERY.

a. Flight delivery, when possible, is the best method of transporting aircraft. An auxiliary fuel tank has been developed for ready installation in the UH-1 passenger compartment. It increases helicopter cruising range and suggests ferrying for most CONUS deliveries.

b. Mode of Transporting E H- 1X Helicopters. It is recommended that EH- 1X helicopters in tactical or logistic configuration be made in an Air Force C5 aircraft in accordance with chapter 6.

1-3. PREPARATION FOR SHIPMENT.

The primary purpose of preparation for shipment is to prevent damage and corrosion. Since the helicopter is only designed to withstand stresses encountered in flight, the packer/shipper must prevent damage from vibration, impact, and other shipping hazards by careful preparation and handling. Mounts and tiedowns described in this manual are designed accordingly. Removal and reinstallation of components for the UH-1 and EH- 1 helicopter shall be in accordance with this manual and TM 55-1520-210-23.

1-4. CONFIGURATION.

a. Individual aircraft configuration may vary due to modifications or mission requirements. No special authorization is required to make minor departures from the manual to cope with such variations.

b. General Description. EH-1X Helicopter. The EH-1X (figure 1-3) is a UH-1H helicopter modified to incorporate an AN/ALQ15L(V1) special purpose countermeasures system which includes the following: Refer to TM 55-1520-210-23-2, paragraph 9-6 through 9-18 and TM 32-5865-007-20, Figure FO-20 for maintenance and troubleshooting procedures.

- (1) Cabin mounted operator seat.
- (2) Cabin mounted mission racks.
- (3) Data and voice link communication antennas mounted to the lower external fuselage.
- (4) BITE antenna mounted to the lower external surface of the tailboom.
- (5) ECM antenna assembly mounted to the rear lower section of the tailboom.
- (6) DF antennas mounted to the left and right side of the tailboom.

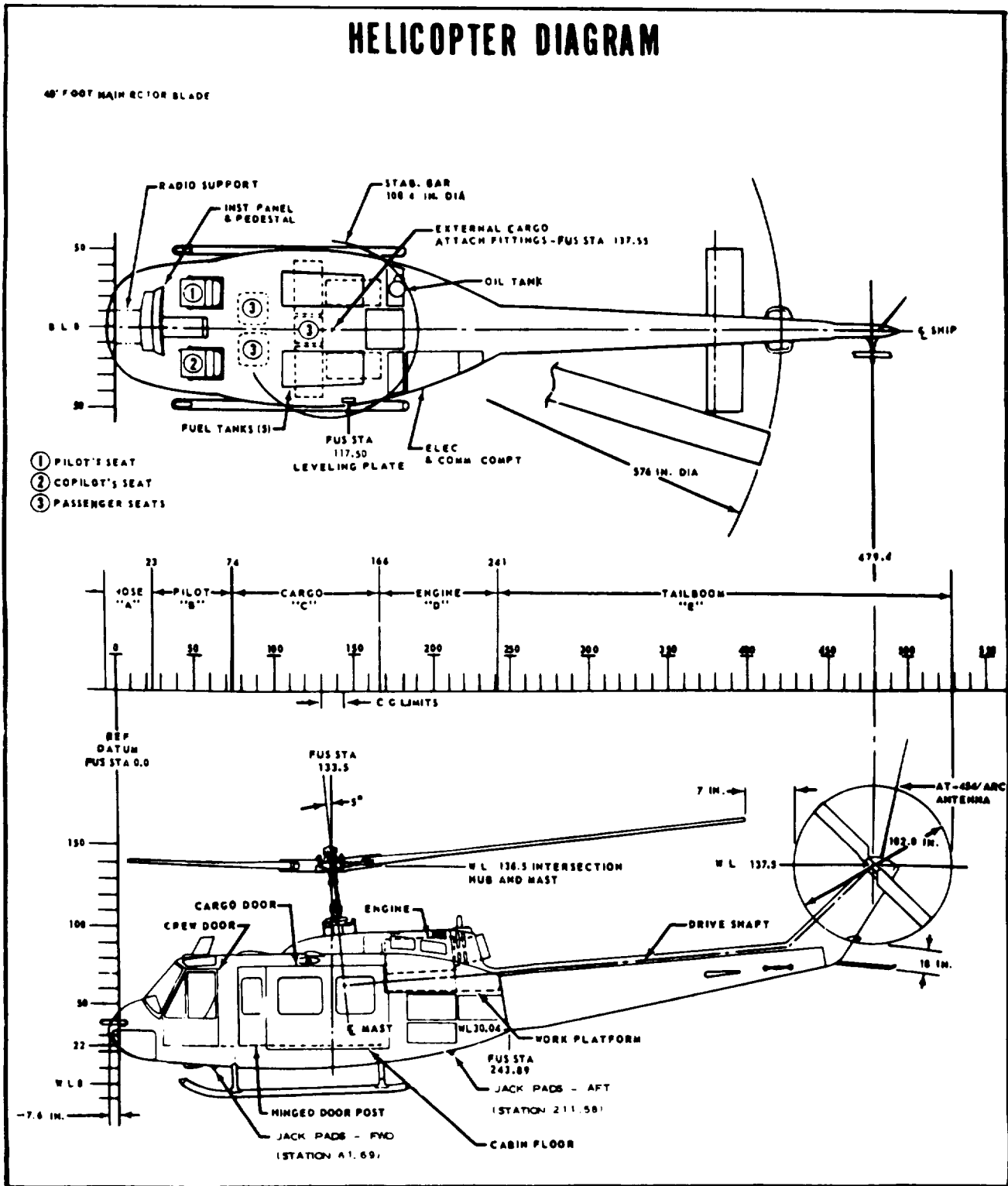

Figure 1-1. UH-1H\V and EH-1H Dimensions.

1-5. DISASSEMBLY.

The governing publications for all disassembly called for in this manual are listed below:

<u>UH-1 Series</u>	<u>Publication</u>
UH-1B	TM 55-1520-219-10/20/34
UH-1C/M	TM 55-1520-220-10/23
UH-1H/V, EH-1H, and EH-1X	TM 55-1520-210-10/23
EH-1X	TM 32-5865-007-10/20&P

1-6. DIMENSIONS.

Overall dimensions for planning space requirements can be found in the appropriate -20 or -23 maintenance manual and on Figures 1-1, 1-2.

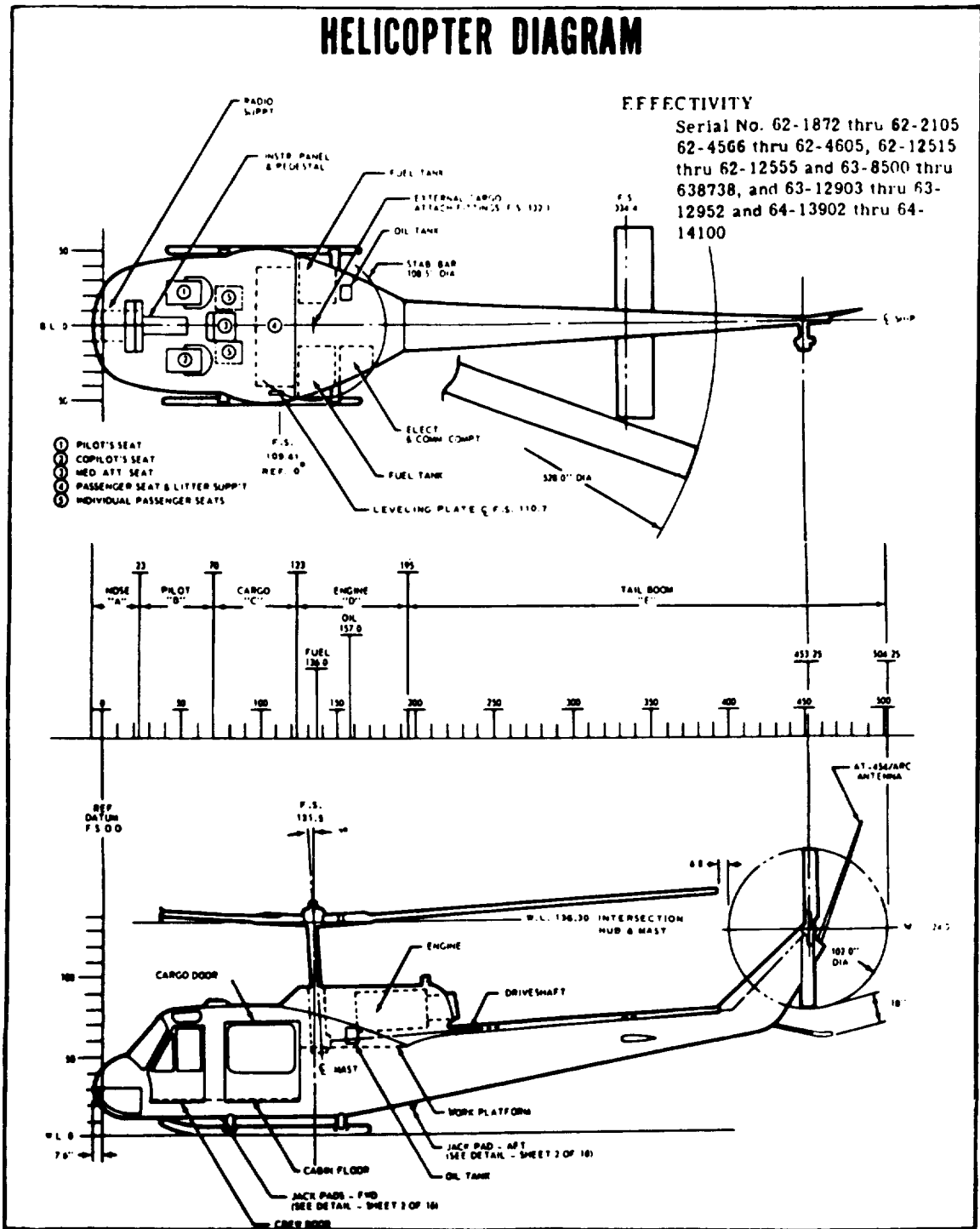

AV 085924

Figure 1-2. UH-1B Dimensions.

1-7. PACKAGING MATERIALS.

a. Cushioning consists of shock absorbing materials or devices that protect components from physical damage. C-12, C-13, and C-22 are acceptable cushioning.

b. When items are protected by contact preservative, the preserved item must be wrapped with barrier material before being cushioned. On partially coated large items, it may suffice to use barrier material only over those areas actually coated. Regardless of use of preservative, barrier material must protect parts which could be damaged by shreds or fragments of cushioning. C-2 and C-3 are suitable barrier materials.

c. All packaging materials are called out in this manual by C-number, referencing Appendix D, Table of Consumables.

SECTION III. PRESERVATION CHECKSHEETS

1-8. PRESERVATION CHECKSHEETS.

The organization actually preserving the helicopter is responsible for writing preservation checksheets. Two copies each of the preservation and depreservation checksheets accompany the helicopter. Place one of each in a waterproof bag (C-1 or similar type), heat seal, and stencil on bag: PRESERVATION AND DEPRESERVATION CHECKSHEETS. Tape bag to control stick with C-25. Place second copy of each checksheet in log book. A preservation checksheet based on provisions of this manual is in Appendix B..

SECTION IV. DEPRESERVATION CHECKSHEETS

1-9 DEPRESERVATION CHECKSHEETS.

The organization preserving aircraft for shipment is responsible for writing depreservation checksheets and forwarding two copies in accordance with paragraph 1-8. Base depreservation checksheets on actual preservation applied. Clearly indicate each operation to be performed during depreservation. Attach conspicuous tags to any item liable to be overlooked in depreservation. A depreservation checksheet is shown in Appendix C.

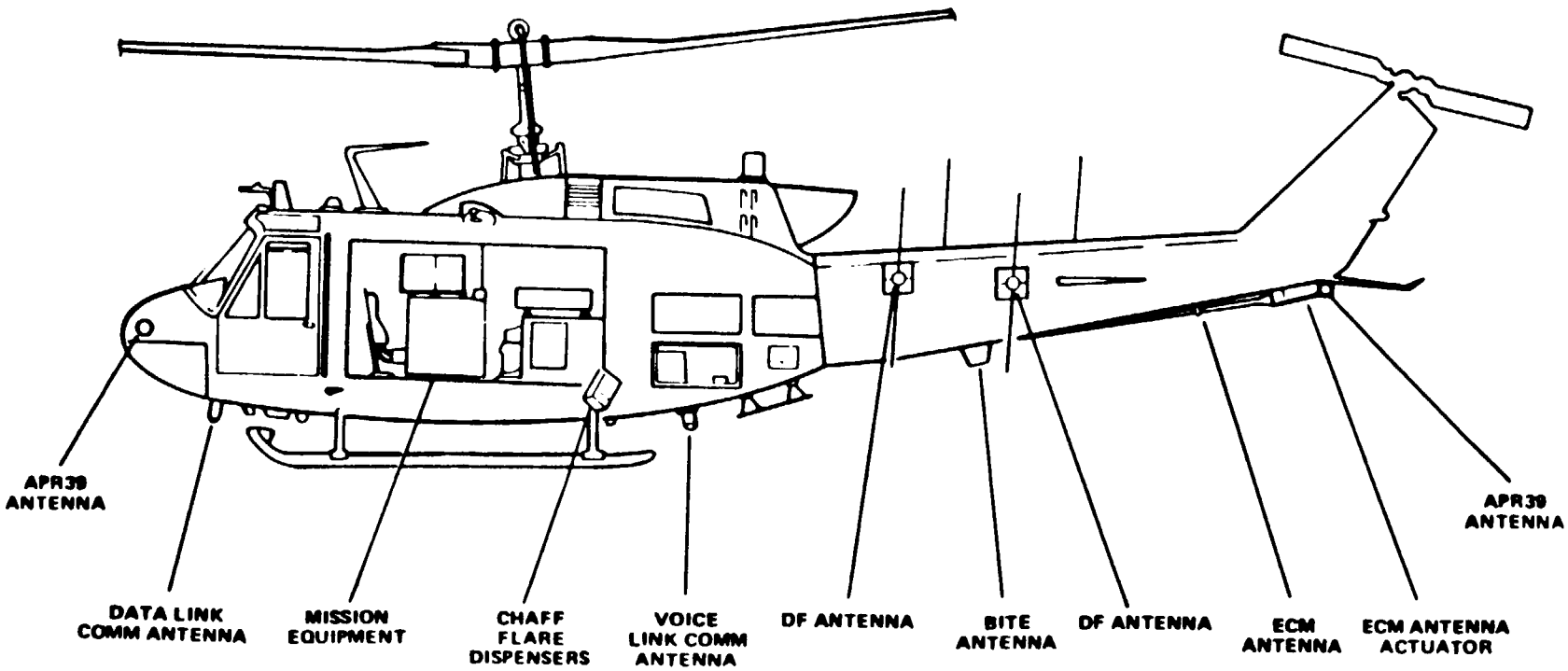

Figure 1-3. EH-1X Helicopter Configuration.

CHAPTER 2

SHIPMENT BY CARGO AIRCRAFT

SECTION I, GENERAL

2-1. GENERAL

This chapter presents technical information on disassembly, preservation, loading, and tiedown for shipment of the UH-1/EH-1 helicopter by cargo aircraft. Preparation for shipment procedures are the same regardless of purpose of movement; however, if it is more important to fully utilize cargo aircraft capacity (as in logistic moves) than it is to minimize overall operation time (as in tactical moves), additional disassembly may be advantageous. This chapter is flexible enough to allow for such changes.

NOTE

Determining aircraft balance and tiedown requirements are functions of the cargo aircraft loadmaster. In case of conflict, Air Force requirements found in T.O. 1C- -9 Series take precedence.

SECTION II, CAPACITIES OF CARGO AIRCRAFT

2-2 . GENERAL

UH-1/EH-1's, disassembled to the extent specified in Tables 2-1 and 2-2, can be carried in Air Force cargo aircraft in the quantities shown in Tables 2-1 and 2-2.

CAUTION

With tailboom overhead, helicopter is nose heavy; with tailboom side mounted, helicopter is both nose and left side heavy. Either fixture makes the UH-1 hard to steer and difficult to move up and down ramps.

b. Cargo aircraft request should include a statement that the load requires full length, width, and height of the cargo compartment, and that all removable items be excluded.

c. When ordering a C-141A or a C-141B, remember that a shelf has been permanently installed between stations 452 and 537 for a C-141A or between stations 292 and 337 for a C-141B. The shelf is 83 inches above the aircraft cargo floor.

TABLE 2-1

DISASSEMBLY OF SERIES UH-1B\C\M HELICOPTERS FOR CARGO AIRPLANE SHIPMENT

CARGO AIRCRAFT MODEL	FOR MINIMUM DISASSEMBLY			FOR MAXIMUM NUMBER OF HELICOPTERS	
	C-5	C-141	C-5	C-141	C-130
Number of UH-1B/C/M's Per Cargo Airplane	8	2-Mdl.A 3-Mdl.B	11(1)	2 -Mdl -A 3-Mdl-B	1
Component:					
Main Rotor Blades		x	x	x	x
Stabilizer Bar	x(5)	x	x	x	x
Rotor Head and Mast Assy			x	x	x
Tail Rotor Blade		x(2)	x	x	x
Synchronized Elevators	x	x(3)	x	x	x
Tailboom			x	x	x
Pitot Tube, (if above windshield)	x		x	x	
Whip Antenna		x	x	x	x
Homing Antenna	x(4)			x(4)	x
VHF/UHF Antenna		x		x	x
ARC-102 Antenna				x	x
Rear View Mirror		x		x	x
Tailpipe Fairing Assy				x	x
Engine Inlet Top Screen Assembly		x		x	x

X Denotes component is to be removed; footnotes modify this.

- (1) Piggyback kit required.
- (2) Secure remaining blade to tail pylon or remove.
- (3) The synchronized elevators may be damaged if not removed as the cargo aircraft doors are only a few inches wider than the elevators.
- (4) Remove if located on nose of helicopter to conserve space.
- (5) Lower half of bar nearest side of cargo plane.

TABLE 2-2. Disassembly of UH-1D/H/VEH-1H for Cargo Airplane Shipment

CARGO AIRCRAFT MODEL	MINIMUM DISASSEMBLY		MAXIMUM HELICOPTERS	
	C-5	C-141	C-5	C-141
Number of UH-1D/H/V EH-1H Component	7 7	2 2	11 (1) 9 (3)	3 (2) 2 (3)
Main Rotor Blades		x	x	x
Stabilizer Bar	x (4)	x	x	x
Rotor Head & Mast Assy		x	x	x
Tail Rotor Blade		x (5)	x (5)	x (5)
Synchronized Elevators	x		x	x
Tailboom	x		x	x
Whip Antenna	x	x	x	x
Homing Antenna			X (6)	X (6)
ARC-102, ARC-199			x	x
Rear View Mirror		x	x	x
Cargo Suspension Assy		x (7)		x (7)
Cargo Door Handle				x
Hinged Panel	X (8)		X (8)	
Tailboom Antenna (EH-1H)			x	
Nose Antenna (EH-1H)	x	x	x	x
ASC-15 Antennas			x	x
Lower Cutter Assembly				
Breakaway Tip (WSPS)		x		x
Upper Cutter Assembly (WSPS)		x		x
DF Antenna, Lower Element (EH-1X)	x	x	x	x
Operator Seat and Rails (EH-1X)	x	x	x	x

X Denotes component is to be removed footnotes modify this.

- (1) Piggyback kits will normally be used on all helicopters shipped in a C-5.
- (2) Side-saddle kits must be available for maximum loads of three in a C-141A or four in a C-141B. This does not apply to the EH- 1H which has no space to store components internally: therefore, the C-141 can load only two EH- 1H's in a Mdl.A or three EH-1H's in a Mall. B.
- (3) Space is required for components which do not fit inside the helicopter.
- (4) Lower half of bar nearest side of cargo plane.
- (5) Secure remaining blade to the tail pylon or remove. When the tailboom is removed or when loading a C- 141, remove both blades.
- (6) Remove homing antenna wands if located on the nose of the helicopter.
- (7) Remove only if the air transportability skids are used.
- (8) Hinged panel (removable door posts on helicopter located just forward of sliding door).

2-3. SIDE-SADDLE KIT,

Use the side-saddle kit (Foldout 2) on the UH-1H/V to reduce overall aircraft length so that three helicopters can be carried in a C-141A *or* four in a C-141B cargo aircraft. Two 463L pallets are required for each helicopter shipped. Advantages are similar to those of the piggy-back kit. (paragraph 2-4 below)

2-4. PIGGY-BACK KIT.

Use the piggy-back Shipping kit (figure 2-1) to reduce UH-1 overall length so that eleven helicopters can be carried in a C-5 cargo aircraft. Use it only when the maximum number of helicopters must be shipped by C-5; reducing cube is its only advantage.

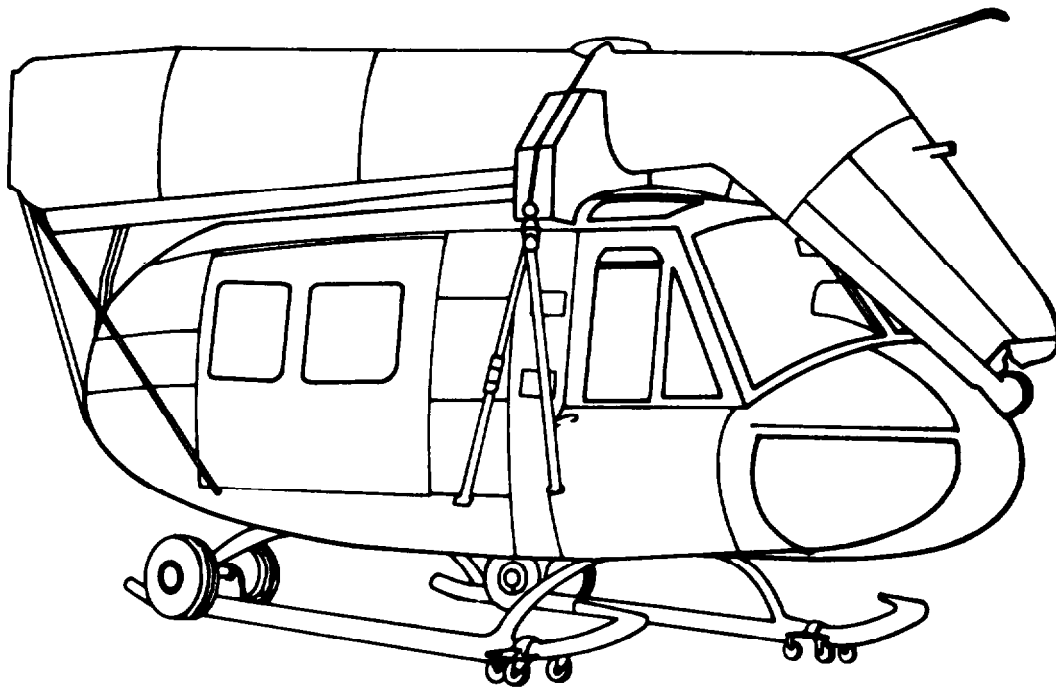

Figure 2-1. Piggyback Configuration.

SECTION III. PREPARING THE HELICOPTER

2-5. GENERAL.

To reduce congestion around the cargo aircraft, complete the following preparations before taking the helicopter to the loading site. Ground helicopter prior to cleaning, disassembly, or preservation.

2-6. CLEANING.

Clean helicopter in accordance with paragraphs 7-1 through 7-6.

2-7. DISASSEMBLY.

a. **Disassembly indicated** in tables 2-1 and 2-2 is based mainly on space and clearance considerations. However, some disassembly remains optional with the shipper, depending on existing conditions. For example, it may be advantageous to remove synchronized elevators to make room for other cargo, or fragile items such as antennas may require removal. Conversely, if time is of greater importance, the shipper may take a calculated risk and leave on components to save disassembly and reassembly time.

b. For the EH-IX helicopter, remove the following components in accordance with TM 55-1520-210-23.

(1) Operator seat and rails.

CAUTION

A damaged DF antenna lower element may render the EH-IX incapable of performing its primary mission. The DF antenna lower elements must be removed during shipment.

(2) DF antenna lower elements.

(3) Wrap antenna elements and hardware in barrier material (C3) and stow in cabin,

CAUTION

To prevent damage and breakage, do not apply pressure to or lean on cabin roof windows while removing upper cutter assembly.

c. Remove the wire strike upper cutter assembly and struts, and the lower cutter breakaway tip (TM 55-1520-210-23).

2-8. PACKAGING AND PRESERVATION.

a. Battery. Preserve battery in accordance with paragraph 7-9.

NOTE

Ensure that landing and search lights are retracted before disconnecting battery.

b. Fuel System.

WARNING

Helicopter gross weight should not exceed 6,300 pounds when using the single wheel modification kit. Therefore, do not carry fuel causing the helicopter to exceed this weight.

WARNING

TM 38-250 requires that all helicopters with purged fuel systems be tested for dangerous fuel vapors immediately prior to loading in cargo aircraft. Test with a combustible gas indicator. If a dangerous level exists, repurge fuel system until a safe reading is obtained. To avoid emergency purging, check fuel system periodically prior to loading.

(1) Helicopter will be shipped with fuel unless there is reason not to. If defueled, drain and purge tanks in accordance with paragraph 7-8.

(2) If fueled, apply provisions of TM 38-250. Fill fuel tanks 3/4 or less with operating fuel. Tag fuel filler caps with the number of gallons and type of fuel contained in each tank.

c. Main Rotor Blades. Preserve main rotor blades in accordance with paragraph 7-11.

d. Restraint Installation.

(1) If UH-1 is shipped with side-saddle kit, drill a 1/2-inch hole in the center of the angle iron of fuselage section of tailboom support. Insert a 1/2inch shackle and attach two 5,000 pound tideown straps. After helicopter is positioned, secure straps to cargo aircraft floor. When an EH-1 is shipped side-saddle in the C-5 the empennage antenna and actuator must be removed.

It is extremely important that the L-shaped tiedown support beam is placed across the cargo compartment exactly as shown in figure 2-2. To ensure that the tie-down beam is installed properly, the joint formed by the nailed together lumber must run vertically and not horizontally. If the tie-down beam is improperly installed and severe turbulence is encountered the joint will open, and the chain will slip between the joint and become slack.

CAUTION

To prevent contact between the tiedown chains and helicopter skin, the L-shaped tiedown support beam shall extend 5 inches past the cargo compartment floor and vertical door post.

(2) If a UH-1 is shipped without side-saddle kit, prepare two tiedown support beams for each helicopter using four pieces of 2x6x100-inch lumber. Nail two pieces together to form a L-shape. Install the beams across helicopter cargo compartment (Figure 2-2) before placing disassembled components in cargo compartment.

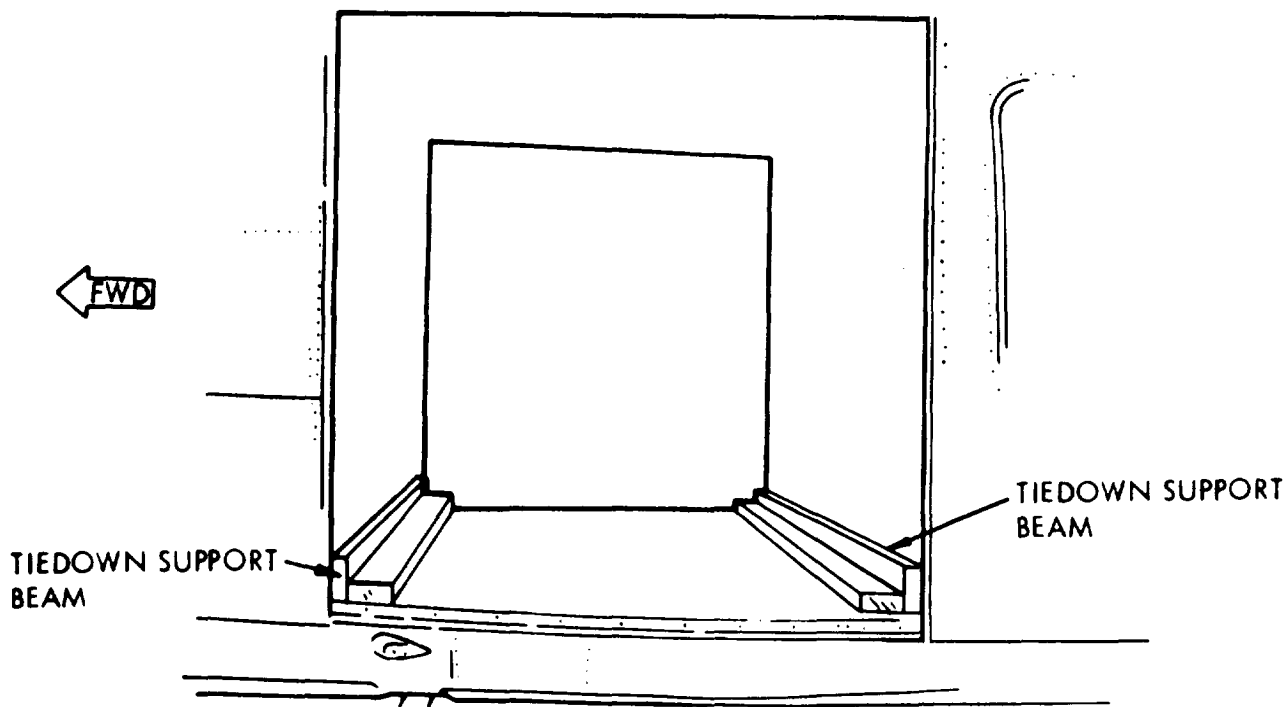

Figure 2-2. Tiedown Support Beams.

CAUTION

When securing the tiedowns, do not exceed a floor load of 100 pounds per square foot.

NOTE

Because of mission equipment installed in the cabin, only a single, lateral tiedown beam (figure 2-2) can be used when tying down the EH-1X.

(3) Join two 10,000 pound tiedown chains with their hooks. Place chains through fuselage, one resting upon forward tiedown support beam, and one resting upon aft support beam. After positioning helicopter secure tiedown devices to tiedown rings on cargo aircraft floor.

(4) The EH-1H has the dimensions of the UH-1H but will require nose and side antenna removal (Figure 2-3).

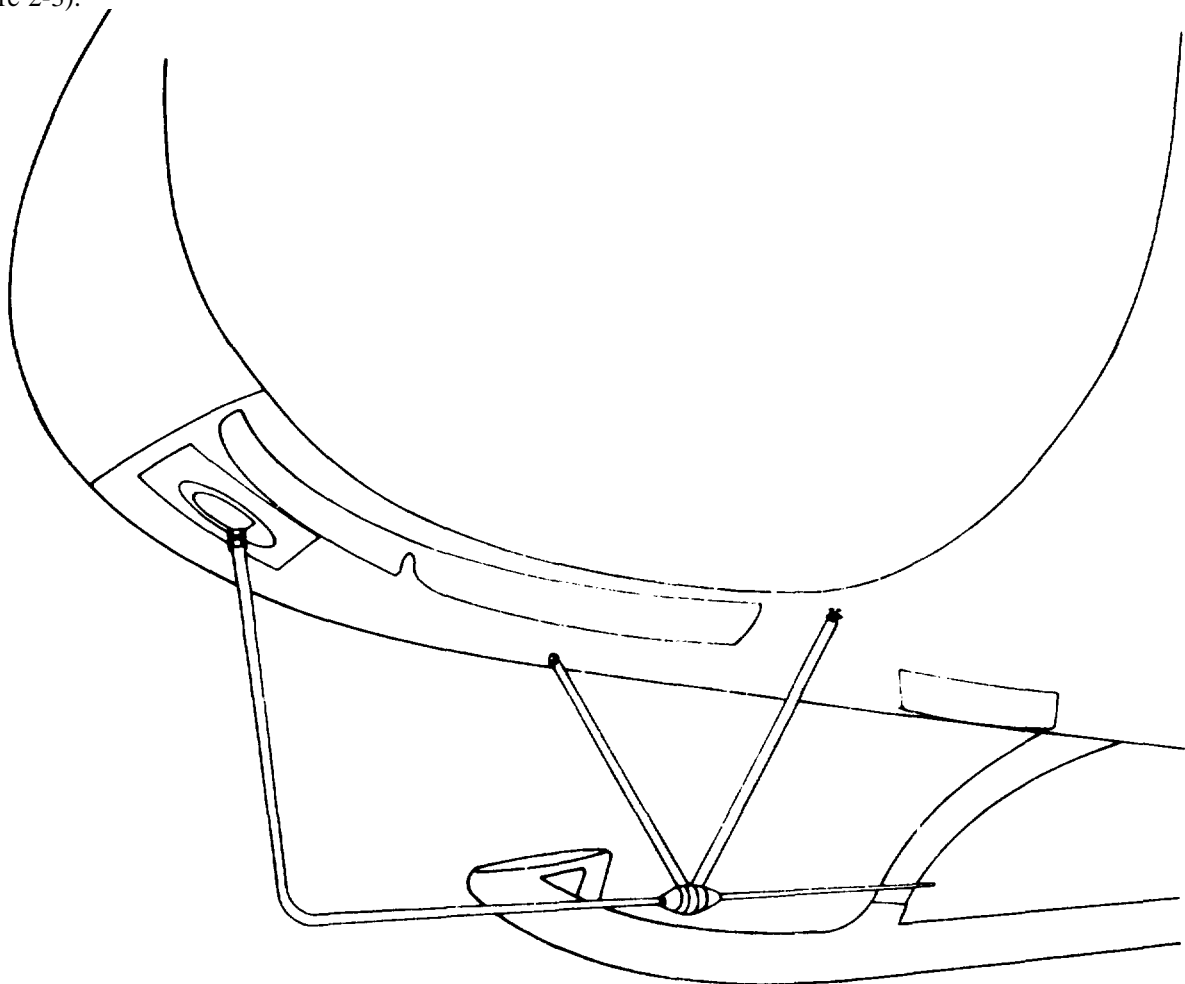

Figure 2-3. Nose Antenna on EH-1H.

(a) Tiedown support beams cannot be installed on the EH-1H helicopter. The user will attach tiedown shackles (See appendix E) at the four aft-upper and lower hard point on each side. Two MC-1 straps will be attached to each shackle in opposite directions. These will be installed at an angle to achieve maximum restraint in all directions. All other tiedowns remain as depicted.

(b) Use of the single handling wheel is predicated upon no fuel being in the aircraft to keep gross weight below the allowable 6300 pounds.

(c) Belly antenna housing precludes use of transportability skids.

NOTE

Components cannot be stored in the cargo compartment of the EH-1H.

e. Stabilizer Bar.

(1) If stabilizer bar is removed, preserve it in accordance with paragraph 7-10.

(2) Wrap stabilizer bar in cushioning (C-12). Secure in helicopter cargo compartment with nylon straps.

f. Main Rotor Hub.

(1) Preserve rotor hub in accordance with paragraph 7-12.

(2) If main rotor hub is removed, coat splines with corrosion preventive (C-10). Wrap removed hub in cushioning (C-12) and secure in helicopter cargo compartment with nylon straps (Figure 2-4).

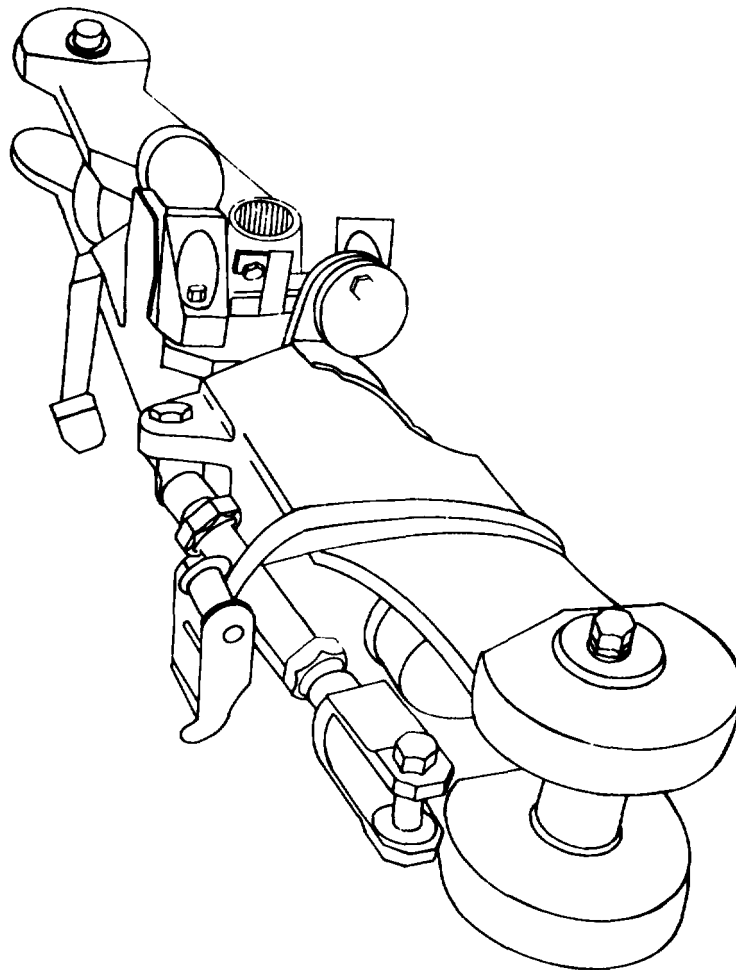

Figure 2-4. Rotor Hub Securement.

g. Main Rotor Mast and Swashplate Assembly.

(1) Preserve mast and swashplate assembly in accordance with paragraph 7-13.

(2) Secure mast and swashplate assembly in helicopter cargo compartment with nylon straps.

h. Tail Rotor Blade(s). Prepare tail rotor blade(s) in accordance with paragraph 7-14.

i. Synchronized Elevators.

(1) Preserve synchronized elevators in accordance with paragraph 7-16.

CAUTION

If spoilers are mounted on upper surfaces of synchronized elevators (UH-1B), pack elevators so that spoilers are adjacent to exterior surfaces of packing box.

(2) Pack elevators in a fiberboard box. Secure box in helicopter cargo compartment with nylon straps.

j. Skid Landing Gear.

(1) Preserve skid landing gear in accordance with paragraph 7-20.

(2) If landing gear is removed, stow it on the cargo aircraft ramp. Secure with 5,000 pound tiedown straps.

k. Tail Boom.

(1) Preserve tailboom in accordance with paragraph 7-17.

(2) If removed tailboom is not secured to fuselage with side-saddle or piggy-back kit, transport tailboom on cushioning (C-12), or on a well-cushioned tailboom rack. Secure tailboom to cargo aircraft floor with nylon tiedown straps.

l. Antennas. Prepare antennas in accordance with paragraph 7-18.

m. Fuselage.

(1) Prepare fuselage in accordance with paragraph 7-21.

(2) If the left door handle is removed (for side-saddle use), put in cloth bag and tie to inside of door.

(3) Temporarily close door and panel openings with barrier material (C-3), secured with tape (C-25), to prevent rain entry into cargo compartment. Close all other fuselage openings in like fashion.

n. Upper and Lower Cutters (WSPS). Preserve upper cutter assembly and lower breakaway tip in accordance with paragraph 7-18.1.

2-9. MARKING.

Apply all markings in accordance with paragraphs 7-22 through 7-25.

SECTION IV. FUNCTIONS OF CARGO AIRCRAFT CREW

2-10. MOVEMENT OF HELICOPTERS.

Helicopters are loaded, tied down, and unloaded by unit or depot personnel with technical advice and assistance provided by the cargo aircraft loadmaster.

2-11. AIR FORCE PERSONNEL CAN BE EXPECTED TO:

- a. Advise and assist Army loading team.
- b. Prepare cargo aircraft for loading and unloading
- c. Rig and operate loading aids organic to cargo aircraft.
- d. Designate location of helicopter(s).
- e. Determine cargo restraint requirements.
- f. Provide tiedown devices.
- g. Inspect for adequacy of tiedown.

SECTION V. FUNCTIONS OF ARMY LOADING TEAM

2-12. COORDINATION.

The Army installation preparing and loading helicopters must coordinate with Military Airlift Command (MAC) to be ready to park, refuel, and load as soon as the MAC cargo aircraft arrives. All concerned must know how many of which series UH-1 are being shipped, and what model cargo aircraft is requested to plan disassembly and obtain proper handling equipment, shoring, and cushioning.

2-13. ARMY LOADING TEAM IS EXPECTED TO:

- a. Prepare helicopter(s) for shipment.
- b. Load, tie down, and unload helicopter(s).
- c. Prepare manifest. Itemizing disassembled components stowed within helicopter as part of fuselage package.

WARNING

Computation of center of gravity (CG) must be exact. Using predetermined CG or estimated weights may cause aircraft instability, jeopardizing cargo and crew.

- d. Mark fuselage CG on the side of fuselage package. Similarly mark major components not stowed within helicopter. Verify and record shipping weights of each major component on manifest.
- e. Furnish lumber and construct extensions to aircraft loading ramp.
- f. Furnish, rig, and operate auxiliary loading devices not organic to cargo aircraft.
- g. Furnish and operate auxiliary lights necessary for night loading.
- h. Furnish cargo aircraft commander DD Form 1387-2, listing all dangerous materials (defined by TM 38-250/AFM 71-4) shipped with or within helicopter. See paragraph 7-25.
- i. be prepared to demonstrate for cargo aircraft commander that components stowed within helicopter are packaged correctly and secured in accordance with Air Force restraint requirements.

SECTION VI. PREPARING THE CARGO AIRCRAFT

2-14. GENERAL.

Cargo aircraft are prepared for loading by Air Force crew assisted by Army loading team. Army personnel construct necessary ramp extensions to change angle of approach to cargo aircraft. Use 2" x 12" x 12' planks properly shored to extend the ramp about 10' thus reducing the angle of inclination. This keeps skid tubes from scraping the ground or gouging the ramp. Figure 2-5 shows a ramp extension for a C-141.

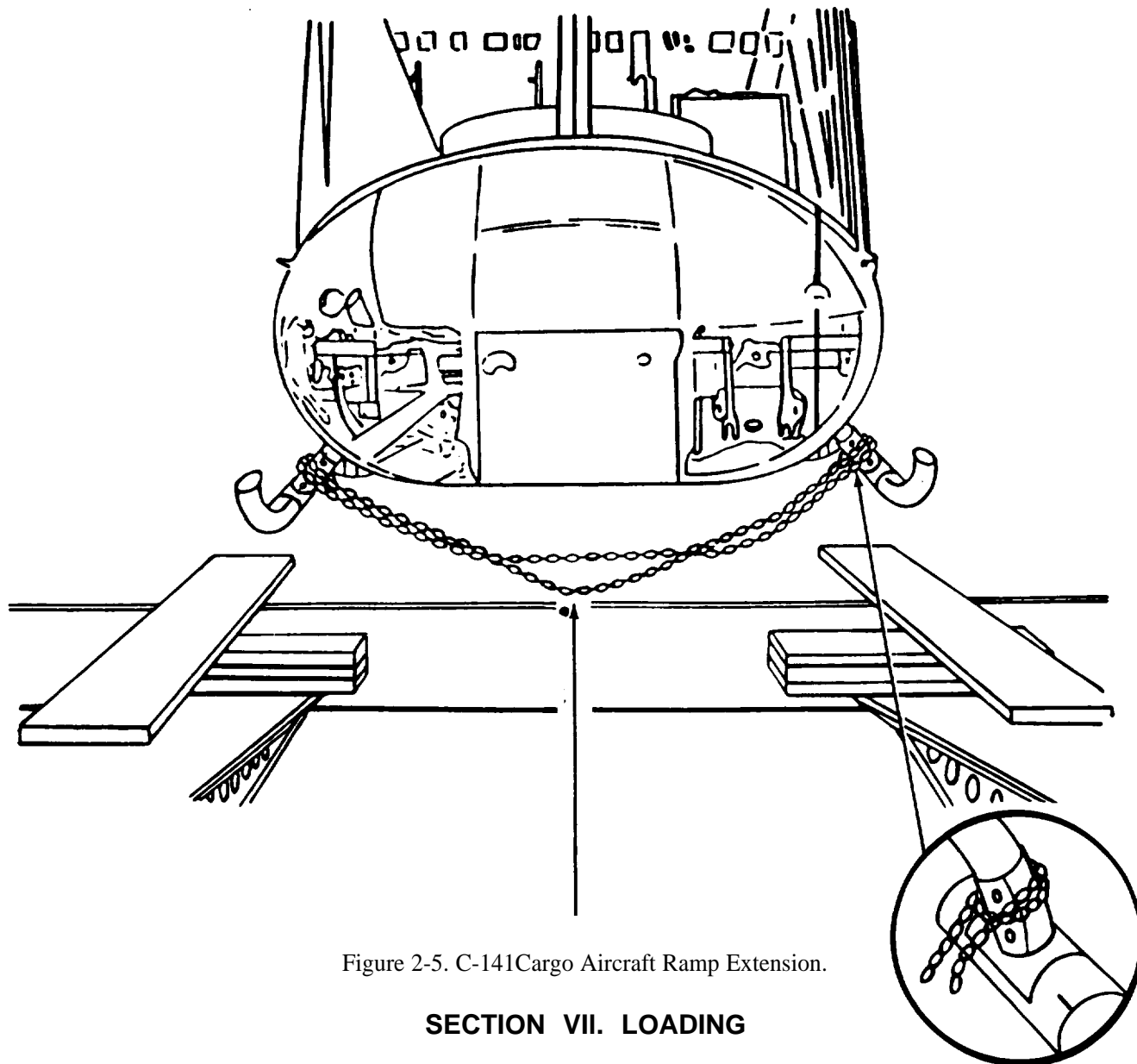

Figure 2-5. C-141 Cargo Aircraft Ramp Extension.

SECTION VII. LOADING

2-15. GENERAL.

WARNING

Test all helicopters with purged fuel systems for dangerous fuel vapors immediately prior to loading in cargo aircraft. Test with a combustible gas indicator. If a dangerous level of fuel vapors exists, repurge until a safe reading is obtained. To avoid emergency purging, check for dangerous fuel vapors periodically prior to loading.

WARNING

Do not use modified ground handling wheels (figure 2-9) on EH-1X helicopters. The EH-1X exceeds the weight limitations for the single wheel.

Detail A



CAUTION

Carry at least one set of ground handling wheels, if used, in the cargo aircraft to ensure their availability at the unloading site. If the tailboom is removed and dolly wheels installed under forward cross tubes, carry a set of dolly wheels as well. Check tires for proper inflation.

CAUTION

Do not abuse ground handling wheels particularly the single wheel configuration by running over such things as 2x4 or planks. This is likely to blow out tires or strain parts of handling wheel supports. When ramp extensions are made of nominal two-inch lumber, reduce the bump at the ends by adding small pieces of wood or cutting the ends to make a gradual slope. This also applies to shoring used on cargo aircraft floor to prevent damage from dolly wheels.

- a. Install dolly wheels and ground handling wheels (figure 2-6) whenever it is necessary to move the helicopter short distances or to load with tailboom removed. These wheels are not used when the helicopter is secured to a 463L pallet.

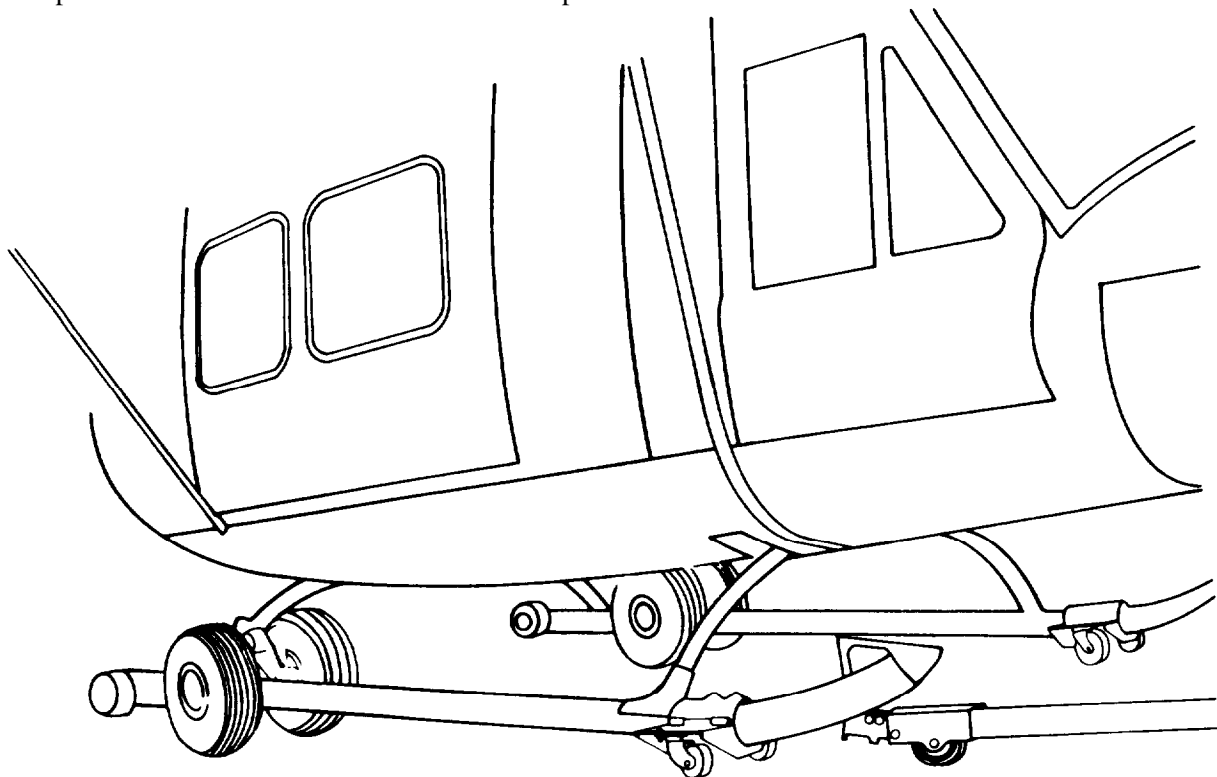

Figure 2-6. Application of Ground Handling and Dolly Wheels.

b. To install or remove dolly wheels, jack helicopter with two 10-ton jacks, type A-6 or equivalent. Do not use crowbars or Johnson bars to install wheels, as these may damage skid landing gears. Use 2x 12 inch dunnage to protect cargo aircraft floor when jacks are used. If only one jack is used, exercise caution to prevent helicopter from being forced against cargo aircraft side or other cargo within aircraft.

c. Load helicopter first to prevent damaging rotor blades. After helicopter is positioned, blades belonging to more than one helicopter can be located under it.

NOTE

Be sure blades are color coded and identified with helicopter serial number.

d. Load the EH-1X helicopter in accordance with paragraph 6-13. In case of conflict, Air Force requirements found in T0-9 series take precedence.

Figure 2-7. DELETED.

All data on page 2-15, including Figure 2-8, deleted.

NOTE

Use padding in all instances of tiedown and tow from cross tubes where they would otherwise be metal-to-metal contact.

2-16. LOADING A C-141 CARGO AIRCRAFT.

a. Side-Saddle Kit. Four UH-1H/V helicopters can be shipped with side-saddle kit installed (FO2). Appendix H gives installation and loading instructions. No load plan is given.

b. UH-1B/CM with Tailboom Removed. Four UH-1B/C/M helicopter can be loaded with tailboom removed. No load plan is given.

(1) Install modified ground handling wheels (figure 2-9) and dolly wheels (figure 2-6)

(2) To pull helicopter up ramp (figure 2-5) into cargo aircraft with aircraft winch proceed as follows (Air Force crew rig and operate winch while Army personnel maneuver helicopter as directed by loadmaster):

WARNING

To prevent injury to personnel and damage to helicopter from the bridle slipping up cross tube, insure that chains are wrapped around the cross tube below the bolts connecting the cross tube to the skid saddles.

WARNING

To prevent injury to personnel and damage to helicopter from bridle chains coming unhooked, secure chain hook to chain link with tape.

WARNING

To prevent injury to personnel and damage to helicopter, do not attach winching bridle to towing rings on skids. These rings will not support the helicopter when moving on ramp.

(a) Make a towing bridle by looping 10,000 pound tiedown chain around each end of padded forward cross tubes. Use three chains on each side. Bring ends together to form triangular bridle.

(b) Station two men on each side to guide helicopter as it rolls up ramp and into aircraft. Station one man to check vertical clearance as helicopter approaches aircraft pressure door.

(c) Attach winch cable to ends of towing bridle. Slowly winch helicopter up ramp.

NOTE

Ensure that ramp is shored to reduce ramp angle.

CAUTION

As modified ground handling wheels approach ramp hinge, place metal strips or plywood under skid tubes and dolly wheels to prevent damage to cargo floor.

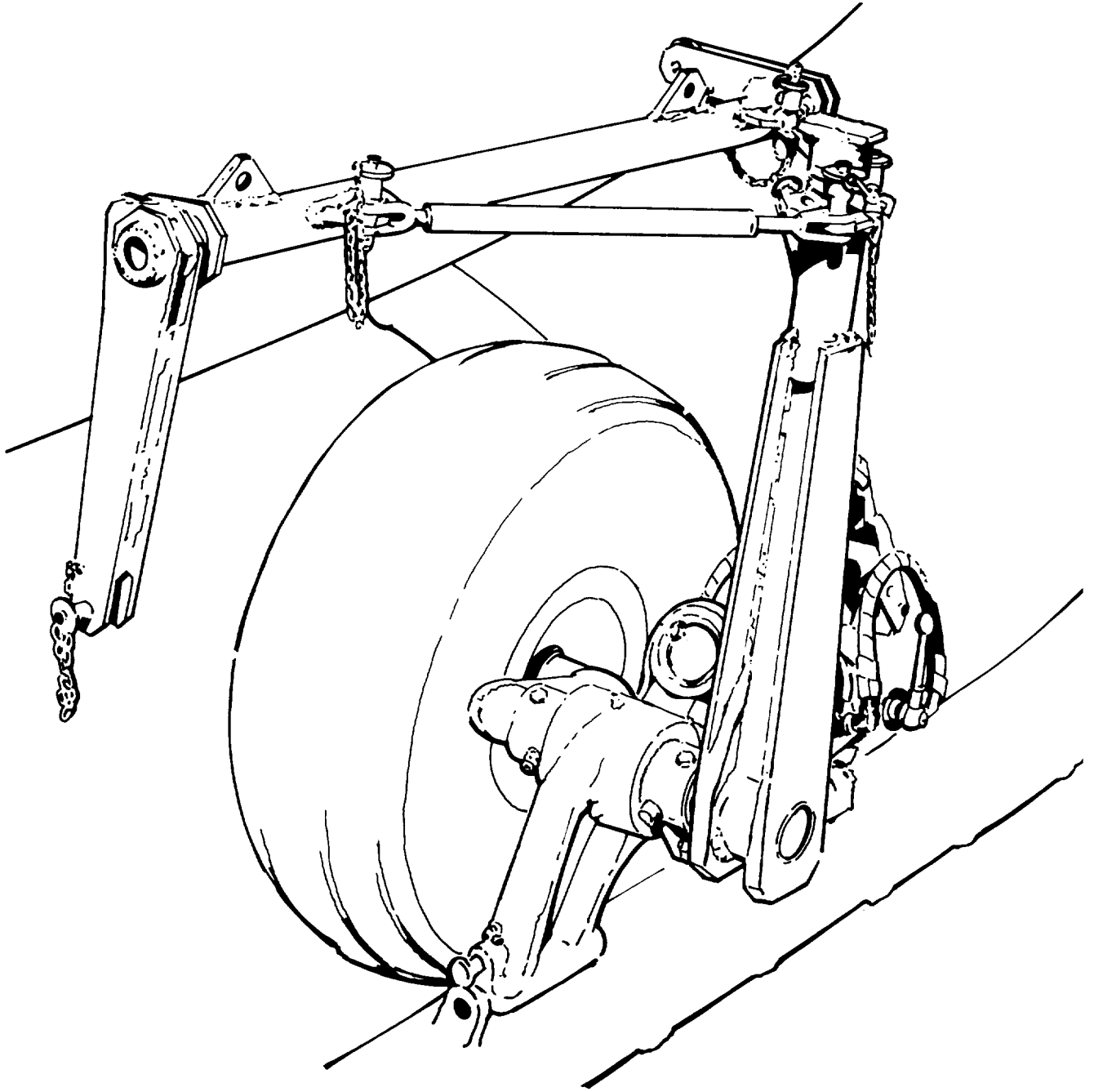

Figure 2-9. Modified Ground Handling Wheels.

(3) winch first helicopter into cargo aircraft until helicopter nose reaches station 500 in Mall. A or station 348 in Mall. B. Release winch hook and remove towing bridle.

CAUTION

Take care when stowing rotor blades not to damage blade tips, drain tubes, or navigation lights. Do not place top of blades forward of station 478 or they may be damaged by personnel walking on them.

(4) Stow rotor blades under fuselage with blade tips pushed forward to station 478.

CAUTION

There must be at least three inches of clearance between helicopters.

(5) Winch second helicopter into cargo aircraft until helicopter nose reaches station 706. Stow rotor blades under fuselage.

(6) Winch third helicopter into cargo aircraft until helicopter nose reaches station 913. Stow blades under fuselage.

(7) Tiedown fuselage and rotor blades as follows:

(a) Secure helicopter to cargo aircraft floor in accordance with figure 2-10.

(b) Secure rotor blades laterally with two 5,000 pound tiedown straps. Take care to cushion blade tops to prevent damage by straps.

(c) Secure blades from forward motion with one 5,000 pound tiedown strap.

(8) Stow and secure tailbooms within cargo aircraft on cushioning (C-12), or place in cradles.

(a) If stowed on cushioning, place one tailboom on left and one on right side of cargo aircraft, with vertical stabilizer toward forward end of cargo aircraft. Load third tailboom in center of cargo compartment and ramp area with vertical stabilizer in a horizontal position and tail rotor assembly up. Secure tailbooms with 5,000 pound nylon straps.

(b) If stowed in cradles, locate cradles at stations 1178 and 1290. Place forward end of tailbooms at station 1120. Secure cradles with 5,000 pound tiedown straps. Secure tailboom with one strap through synchronized elevator port and one strap over flat portion on forward end of tailboom.

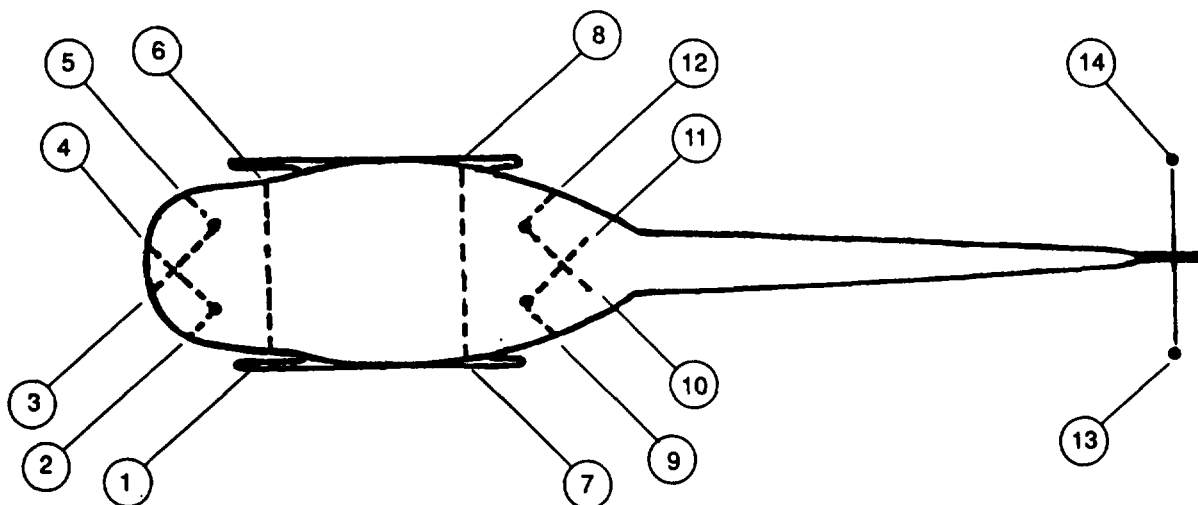

CAUTION

**EXCESSIVE TENSION ON TIEDOWNS
WILL RESULT IN STRUCURAL FAILER
OF HELICOPTER. TIGHTEN ONLY
ENOUGH TO REMOVE SLACK.**

HELICOPTER Attachment POINT	TIEDOWN DEVICE NO.	TYPE
MOORING RING	2,3,4,5,9, 10,11,12	MB-1
LOCAL MANUFACTURE (CROSS BEAM SEE FIG. 2-2)	1,6,7,8	MB-1
TAIL SKID	13,14	CGU-1 B

Figure 2-10. Tiadown Diagram for a UH-1 in a Cargo Aircraft

2-17. LOADING A C-5 AIRCRAFT

a. General. Eleven UH-1H helicopters can be loaded with tailbooms removed and piggy-back kit installed (Table 2-2 and FO-1). Install piggy-back kits in accordance with Appendix G.

b. Loading from a K-Loader or Flat-Bed Truck.

(1) **If piggy-back kit is used install** modified ground handling and dolly wheels, (figure 2-6).

WARNING

Stand clear of modified ground handling wheels while loading bolts have broken, injuring loading personnel.

(2) Hoist helicopter aboard K-loader or flat-bed truck with a crane of at least 7,000 pounds capacity. Secure helicopter to conveyance with 5,000 pound tiedown straps.

(3) Move K-loader or flat-bed against cargo aircraft ramp to obtain a continuous surface between cargo aircraft floor and vehicle. Release tiedown straps.

(4) A minimum of six men constitute the loading team. Station one man on each side to check side and overhead clearance. Station two men at tail end to move and/or guide helicopter into cargo aircraft. Another man operates K-loader or flat-bed.

(5) Manhandle helicopter into position shown in FO- 1.

(6) Tiedown helicopter in accordance with figure 2-10.

(7) If tailboom is installed, attach a strap between tail skid and floor tiedown ring. Make strap SNUG TIGHT only.

CAUTION

Ensure that tiedown chains do not contact thin helicopter skin. Tighten chains one-hand tight to prevent over-stressing helicopter skin.

(8) Secure 10,000 pound tiedown chain (over tiedown beams) to tiedown rings on cargo aircraft floor which are inboard of fuselage and forward/aft of support beams. Carefully hand tighten all tiedown devices.

(9) Stow main rotor blades under each helicopter as it is loaded. Secure to cargo floor.

(10) Ship at least two sets of ground handling equipment with each cargo aircraft.

c. Loading by Winching.

(1) Install modified ground handling wheels being aware that bolts have broken injuring loading personnel.

(2) Construct ramp extensions in accordance with figures 2-11 or 2-5.

(3) **A minimum of seven men constitute the loading team. Station one man on each side to check side and overhead clearance as helicopter is maneuvered within the cargo aircraft. Place four men at the end of tailboom to prevent vertical stabilizer from hitting cargo aircraft ceiling as helicopter moves up ramp.**

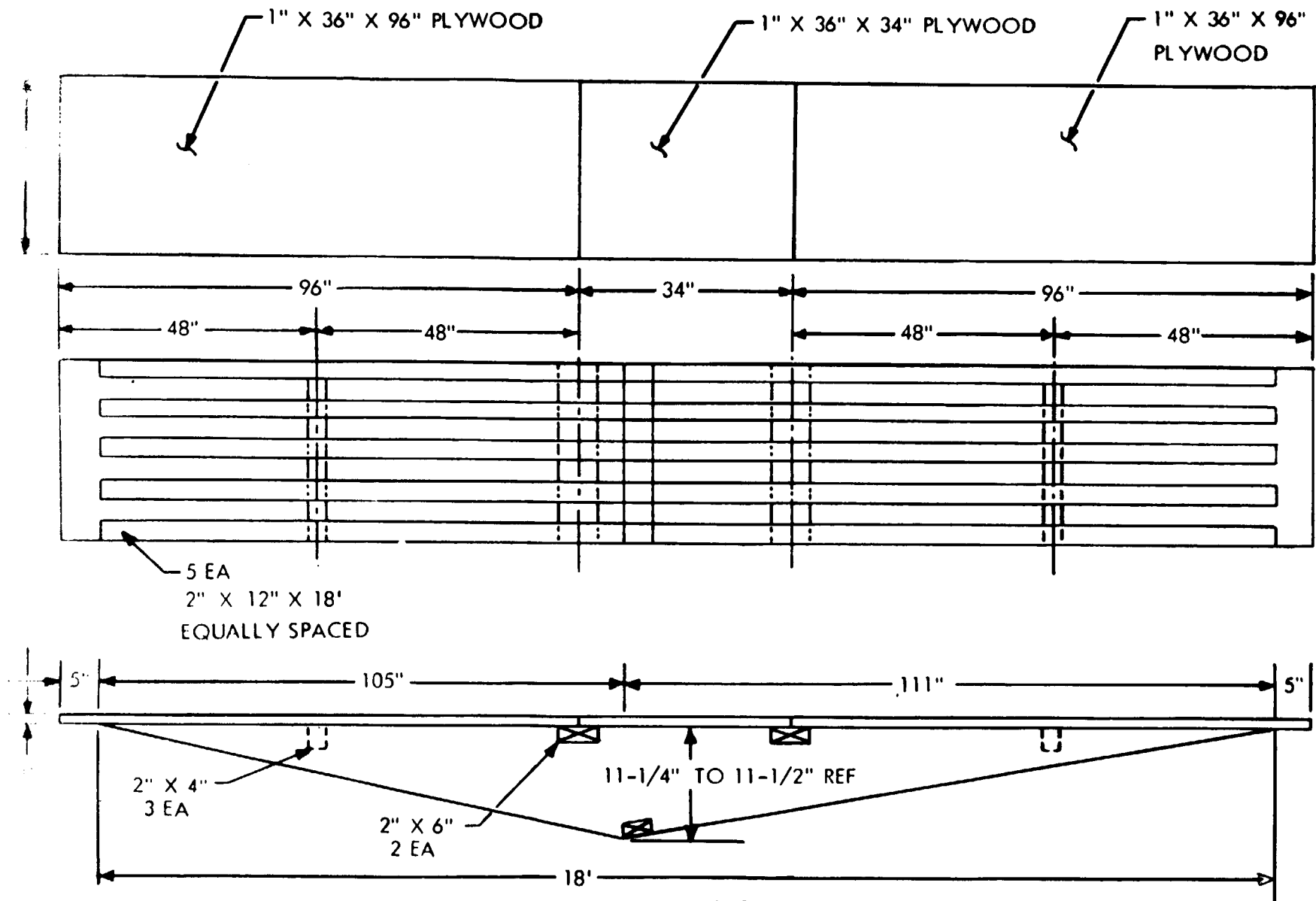

NOTES:

1. ALL LUMBER IN NOMINAL DIM.
2. NAILED CONSTRUCTION.

Figure 2-11. C-5 Ramp Extension.

(4) Make towing bridle by looping six 10,000 pound tiedown chains as described in para 2-166 (2). Connect winch hook to towing bridle.



Ensure that open portion of winch hook is up, or cargo floor maybe damaged.

(5) Winch helicopter up ramp with electric winch and snatch blocks. Cargo aircraft crew rig and operate winch, while Army personnel maneuver helicopter as directed by cargo loadmaster.

(6) As cable slack is taken up, lift tailboom until helicopter is far enough up ramp to let it down without dragging tail skid

(7) As tail pylon approaches cargo aircraft doorway, pull tailboom down to keep pylon from hitting ceiling.

(8) To protect cargo floor, place metal strips under aft end of skid tubes and dolly wheels as they approach ramp hinge.

(9) As soon as handling wheels reach horizontal section of cargo floor, release winch hook and remove towing bridle. Manhandle helicopter into position indicated in FO-1.

(10) Tiedown helicopter in accordance with paragraph 2-17 above.

(11) After each helicopter is loaded, secure main rotor blades under fuselage in accordance with paragraph 2-16b above.

d. Loading with Pallets. The technique for loading with pallets is similar to that for side-saddle kit; however, there is no space savings and its expediency is negated by the large number of pallets involved

2-17.1. PREPARATION FOR SHIPMENT BY C-130 CARGO AIRCRAFT.

a. Prepare aircraft in accordance with TM 55-1520-242-S as if for shipment by C-141. In addition to the components shown as requiring removal by Table 2-2 for minimum disassembly shipment by C-141, the following components must be removed.

1. Pitot Tube.
2. UHF/VHF Antenna.
3. Number 2 FM Antenna
4. Synchronized Elevators.

b. Construct ramp extensions in accordance with paragraph 2-14 of TM 55-1520-242-S. Reduce the bump at the ends of the extension by cutting the ends of the 2x2's at an angle or by adding small pieces of wood

c. Place 1-1/2 ft. wide strips of sheet aluminum or plywood on cargo aircraft floor along path that helicopter skid tubes will travel. This will protect cargo aircraft floor from damage by skid shoes.

WARNING

To prevent injury to personnel helicopter gross weight should not exceed 6,300 pounds when using the single wheel modification kit.

WARNING

To prevent injury to personnel stand clear of modified ground handling wheels while handling aircraft.

- d. Install modified ground handling wheels as shown by Figure 2-9 in TM 55-1520-242-S.

CAUTION

Do not run over rocks, planks, or holes when using the ground handling wheel modification kit. Bumps may cause tires to blow, failure of wheel adapter and/or failure of aircraft hard points.

CAUTION

Do not attempt to load the UH-1 tail first. Clearance cannot be maintained between the helicopter tail and the C-130 ceiling.

- e. Position aircraft at base of ramp extensions with the helicopter nose first into the cargo aircraft.

WARNING

To prevent injury to personnel and damage to helicopter from bridle slipping up crosstube, insure that chains are wrapped around the crosstube below the bolts connecting the crosstubes to the skid saddles.

WARNING

To prevent injury to personnel and damage to helicopter from bridle chains coming unhooked, secure chain hook to chain link with tape.

WARNING

To prevent injury to personnel and damage to helicopter do not attach winching bridle to towing rings on skids. These rings will not support helicopter when moving on ramp.

- f. Using a minimum of three MB-1 chains per side, form a chain winching bridle around front crosstubes (Figure 2-11.1). Wrap the chains twice around the bottom of the crosstube strut, below the connecting bolts. Attach winch cable hook to chain bridle and remove slack from cable.

CAUTION

Insure that open portion of winch hook is up or cargo floor may be damaged.

- g. Station one person on each side of ramp in front of helicopter to signal and insure helicopter clearance. Station six people at tail of helicopter to control helicopter and keep it from hitting side and roof of cargo airplane.

WARNING

Clearance is critical and must be closely watched.

h. Winch helicopter into cargo aircraft with the cargo aircraft winch. Cargo aircraft personnel will rig and operate the winch, while Army personnel maneuver helicopter into place on to 3/4 inch plywood shoring as directed by loadmaster.



Helicopter must be kept in a tail low attitude to prevent hitting the cargo aircraft roof with the vertical stabilizer.

i. Place two positioning blocks (Figure 2-11.2) one under each skid, directly beneath forward crosstube. Lower helicopter onto blocks insuring clearance is maintained between the helicopter vertical stabilizer and the cargo aircraft roof. Restrain forward movement of blocks with tiedown straps.

j. Load rotor blades into cargo aircraft. Place blades on cushioning beneath helicopter. Old mattresses, cushioning material (C- 12) or similar may be used for cushioning.



Take care when stowing rotor blades to prevent damage. Particular care must be taken to avoid damage to or altering angles of blade trim tabs.

k. Construct two "L" shaped tiedown beams in accordance with TM 1-1520-250-23-1 or TM 55-1520-210-23-1. Remove hinged panels (small doors in front of cargo doors) and latch cargo doors open. Place tiedown beams in cargo compartment as shown in Figure 2-2 and the instructions of the cargo aircraft loadmaster.

NOTE

The cargo aircraft loadmaster is the approving authority for positioning and security of the helicopter and components.

SECTION VIII. TIEDOWN

2-18. TIEDOWN

a. Tiedown instructions are given on figure 2-10. This shows a helicopter super-imposed on tiedown fittings of a typical cargo aircraft floor. Points with numbered flags are floor tiedown fittings. Fasten the opposite end of each strap of chain to the helicopter as indicated.

CAUTION

Do not put too much tension on straps attached to helicopter tailboom. Due to the long lever arm, a slight stress is multiplied to the point of structural damage to helicopter.

b. Apply the appropriate tiedown plan. Attach a tiedown device of at least specified strength to attachment points indicated in figure 2-10. Aircraft tiedown fittings are not identified because the exact helicopter location in the cargo aircraft cannot be determined until component weight and balance data is known. The cargo loadmaster designates where the helicopter(s) will be placed in the cargo compartment .

c. Secure items within helicopter to satisfy the following Air Force restraint requirements forward 3 G's; lateral and aft, 1 1/2 G's; vertical, 2 G's.

SECTION IX. OFFLOADING

2-19. GENERAL.

Offloading procedures are generally the reverse of loading. Rate of descent must be controlled as the helicopter rolls down the inclined floor and ramp. Perform the following before unloading.

a. Extend cargo aircraft loading ramp with 2" x 8" x 10 or 12 foot boards supported by shorter pieces underneath. Shoring used in loading should have been shipped with helicopter.

b. Position one man at each side of ramp to relay signals to and from aircraft loadmaster.

c. Position four men at helicopter tail to guide tail and prevent it from striking aircraft or ground as it descends ramp. Secure a nylon web strap around tail skid to enable them to control tail more effectively.

d. Install ground handling wheels.

e. Move helicopter to inclined floor or ramp.

CAUTION

Ensure that open portion of winch hook is UP, or cargo floor may be damaged.

f. Make towing bridle by looping 10,000 pound tiedown chains around each padded crosstube junction with the skid. Use two chains on each side. Use a third chain to join the chains together thus forming a triangular bridle.

2-20. OFFLOADING BY WINCH.

a. Connect the winch to the bridle.

b. Slowly allow the helicopter to roll down the ramp while Army personnel maintain its direction and weight on the wheels by means of tail elevation.

c. When on the ground and clear of the cargo plane, remove the winch hook and bridle.

2-21. OFFLOADING BY MANPOWER.

a. Attach two 5,000 pound tiedown devices to the bridle apex.

b. Attach movable hooks of each strap to a tiedown fitting so that the quick-locking device may be shut instantly.

c. Position two men at the end of each strap.

d. Place four men at helicopter tail to guide and control tailboom as helicopter is offloaded.

e. Pull helicopter to start it down the incline. At the same time pry out on restraining straps.

NOTE

Men controlling the restraining straps should be prepared to shut quick-locking device at first sign of trouble.

f. Allow helicopter to roll down ramp and along the ground until it clears the cargo plane.

g. Remove the bridle and straps.

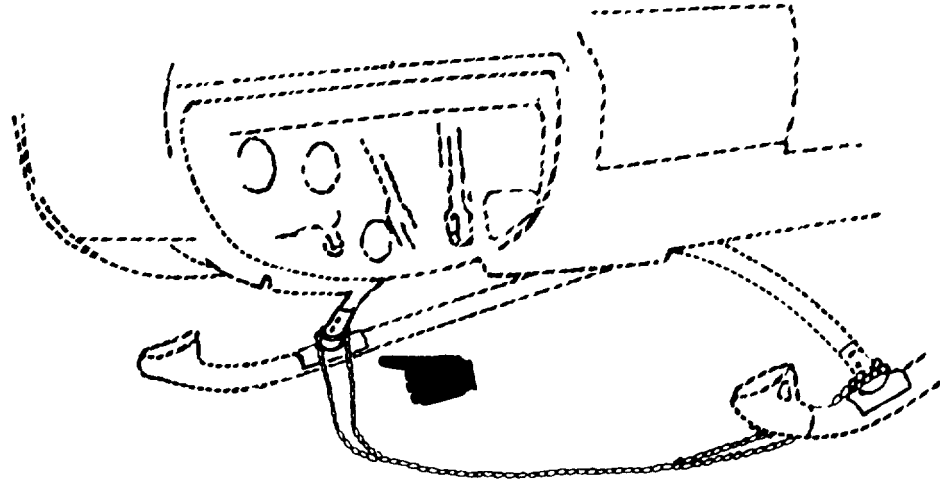

Figure 2-11.1 MB-1 Chain Winching Bridle Attached to Helicopter for Winching

POSITION BLOCK
(2 REQ'D)

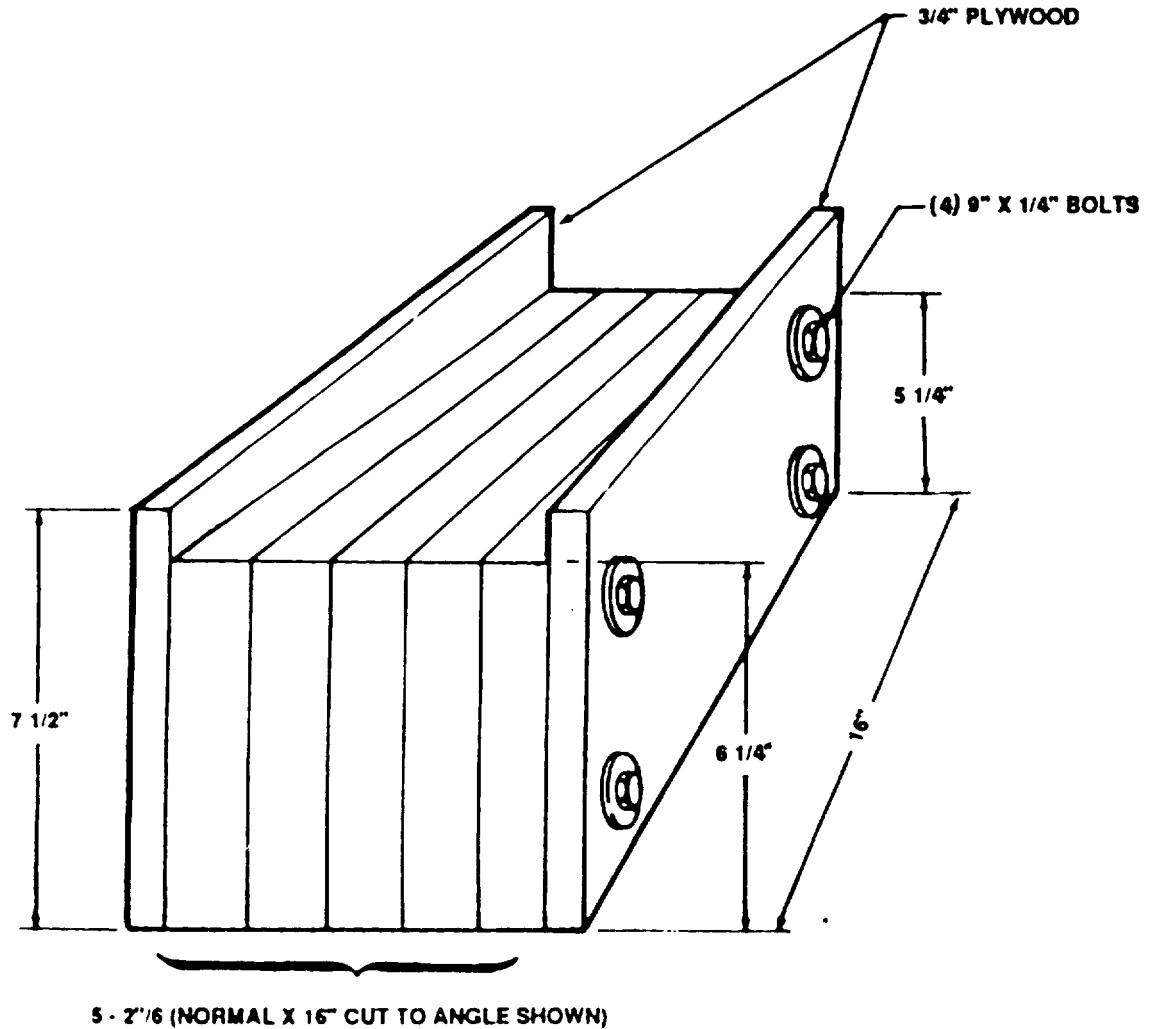

Figure 2-11.2 Position Block

CHAPTER 3

SHIPMENT BY VESSEL

SECTION I. RESPONSIBILITIES

3-1. MTMC.

Military Traffic Management Command (MTMC) is responsible for making necessary arrangements with Military Sealift Command (MSC) for use of ocean vessels when contacted by the appropriate command. MTMC is also responsible for arranging with a service stevedore activity or a commercial stevedore firm to load and tiedown helicopters and components, and for supervising these activities. MTMC, with MSC, prepares loading plans and manifests after close coordination with the shipper.

3-2. SHIPPER.

The shipper is responsible for cleaning, disassembly, preservation, and packing of aircraft and components. He furnishes MTMC any information required to efficiently load the vessel, such as weight and cube, fueled or unfueled, covered or uncovered. The shipper should be available to advise on loading and tiedown procedures as necessary. Shipper shall coordinate with MTMC to determine if aircraft are to be shipped top deck or below deck. Aircraft shipped top deck require protective heat shrink film covering in accordance with Appendix G.

SECTION II. PREPARING THE AIRCRAFT

3-3. CLEANING.

Clean aircraft in accordance with paragraphs 7-1 through 7-6.

3-4. DISASSEMBLY.

a. Remove main rotor blades, one tail rotor blade, all necessary antennas and gunsights. Remove windshield wiper blades and arms for flight deck shipment.

b. Synchronized elevators are not normally removed unless space is at a premium.

c. Remove stabilizer bar for shipment below deck. If the helicopter is flown or delivered to the dock with stabilizer bar installed, it is permissible to ship helicopter on flight deck with stabilizer bar installed and supported in accordance with F03. This involves risk of damage from careless handling. Personnel, hoisting cables, and lines should never contact it.

3-5. PRESERVATION.

a. Battery. Preserve battery in accordance with paragraph 7-9.

- b. Engine and Gear Boxes. Preserve engine and gearboxes in accordance with paragraph 7-7.
- c. Fuel Tanks. Preserve fuel tanks in accordance with paragraph 7-8.
- d. Stabilizer Bar. If stabilizer bar is removed, preserve it in accordance with paragraph 7-10.
- e. Main Rotor Blades. Preserve main rotor blades in accordance with paragraph 7-11.
- f. Main Rotor Head and Mast Assembly. Preserve main rotor head and mast assembly in accordance with paragraph 7-12 and 7-13.
- g. Tail Rotor Blades. Preserve tail rotor blades in accordance with paragraph 7-14.
- h. Tail Rotor Assembly. Preserve tail rotor assembly in accordance with paragraph 7-14 and 7-15.
- i. Plexiglass. Prepare plexiglass in accordance with paragraph 7-19.
- j. Bare Metal Surfaces. Preserve bare metal surfaces in accordance with paragraph 7-20.
- k. Fuselage. Prepare fuselage in accordance with paragraph 7-21.
- l. Install shipping covers in accordance with directions accompanying covers.

3-6. MARKING.

Mark in accordance with paragraphs 7-22 through 7-25.

3-6.1. SHIPPING COVERS. DELETED.

SECTION III. LOADING

3-7. LOADING.

- a. Hoist helicopter by a clevis installed to mast nut. When heavy dock equipment is used, a shackle adapter (F05) may be substituted for the clevis.



No gouges or deep scratches on any part of landing gear can be tolerated. Use of chains or wire rope without adequate protection would ruin landing gear.

- b. Attach ropes to tail skid or to landing gear to prevent swinging. Never restrain elevator or tie to tail rotor blade.

SECTION IV. TIEDOWN

3-8. MOORING.

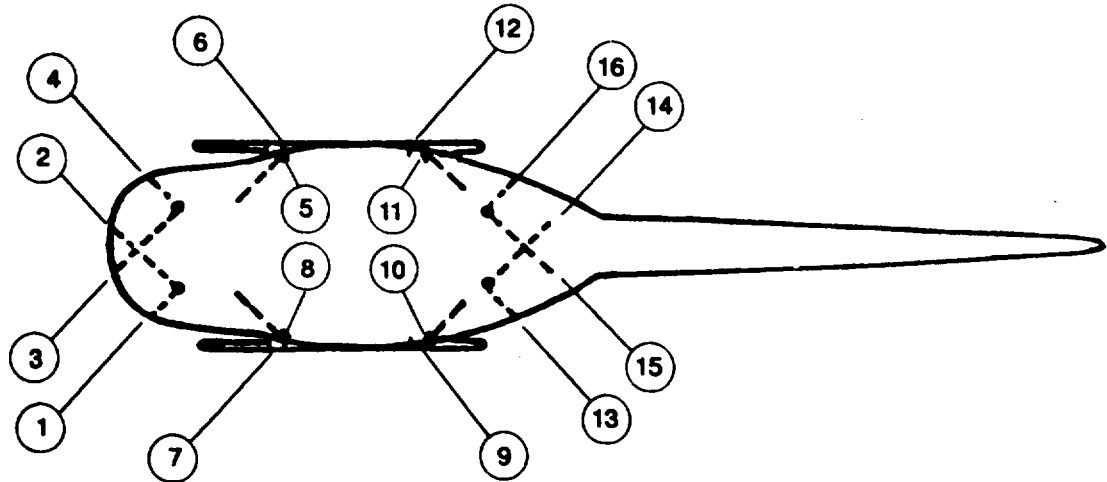

WARNING

PLACE PLYWOOD UNDER SKIDS TO PREVENT FIRE HAZARD FROM SKIDS SPARKING ON STEEL.

CAUTION

PAD SKID CUFF MOORING POINTS TO PREVENT DAMAGE FROM CHAIN.

CAUTION

EXCESSIVE TENSION ON CHAINS WILL RESULT IN STRUCTURAL FAILURE OF HELICOPTER. TIGHTEN ONLY ENOUGH TO REMOVE SLACK.

NOTE

TIEDOWN NUMBERS 5,8,10, AND 11 MAY BE ELIMINATED ON FAST SEALIFT SHIPS (FSS).

HELICOPTER ATTACHMENT POINT	TIEDOWN DEVICE NO.	TYPE
MOORING RING	1,2,3,4,13,14,15,16	MB-1
SKID TO CROSS TUBE CUFF	7,8,9,10,11,12	MB-1

Figure 3-1. Tiedown Diagram for a UH-1 in a Vessel

SECTION V. CARE DURING SHIPMENT

3-9. CARE ENROUTE. To avoid corrosion damage, improper tiedown tension, and prevent security violations, a maintenance escort shall be provided to inspect aircraft daily as follows:

- a. Inspect tiedown cables for proper tension. Care shall be taken to avoid excessive tension which could damage aircraft structure.
- b. Inspect the shipping cover for fit, damages and security to prevent corrosion and unauthorized intrusion. Damage to the cover shall be repaired using the repair kit and instructions stored in the pocket located in the right nose section of the cover. Inspect the shrink film in accordance with Appendix G.

3-10. ARRIVAL AT DESTINATION. After arrival at final destination remove heat shrink film in accordance with Appendix G. Wash the aircraft, particularly the landing gears and stints, using a low pressure spray cleaner and clear water.

- a. With the cover installed on the aircraft, wash the cover using a pressurized spray cleaner and clear water.
- b. Remove the cover, dry thoroughly, and store it in the original container.

CAUTION

Aircraft that have been exposed to salt water may require more extensive cleaning and preservation.

- c. Wash the aircraft using a pressurized spray cleaner and clear water.

CHAPTER 4

SHIPMENT BY TRUCK OR RAIL

SECTION 1. GENERAL

4-1. GENERAL.

a. When feasible, flight delivery is the fastest method of transport; air cargo shipment is the alternate transport method. But when directed by the Commander or AVSCOM, or under emergency conditions, serviceable and repairable aircraft may be transported within CONUS by low-boy truck. The entire helicopter is highly susceptible to shock and vibration damage; use only low-boy trucks with soft-ride air suspension to transport helicopters. No acceptable procedures have been established for rail shipment. For further information, contact US Army Aviation Systems Command, ATTN: AMSAV-SDP.

b. Use judgment in omitting or reducing preservation and physical protection for short hauls under controlled conditions.

c. Responsibilities. The Military Traffic Management Command (MTMC) has the responsibility to supply suitable trucks when contacted by the appropriate command. MTMC shall prepare a loading plan and manifest under close coordination with the shipper. Cleaning, disassembly, preservation, and packing of aircraft is the responsibility of the shipper. Ah-craft are to be delivered to the loading point at a time designated by MTMC. The shipper shall furnish MTMC with information required to efficiently load the vehicle, and will be available to give advice on loading and tiedown procedures as necessary.

4-2. CLEANING.

Clean helicopter in accordance with paragraphs 7-1 through 7-6.

SECTION II. PREPARATION

4-3. DISASSEMBLY.

a. Perform all disassembly in accordance with the appropriate maintenance manual.

b. For all truck shipments, remove the following components:

- (1) Main rotor blades.
- (2) Stabilizer bar.
- (3) Main rotor hub.
- (4) Main rotor mast and swashplate assembly,
- (5) Synchronized elevators.
- (6) Tail rotor blades.
- (7) Ant.ennaes, as necessary.

c. If three or more helicopters are shipped, also remove tailbooms.

4-4. PRESERVATION AND PACKAGING.

a. Engine. Preserve engine in accordance with paragraph 7-7.

TM 55-1520-242-S

b. Fuel System. Preserve fuel system in accordance with paragraph 7-8.

c. Gear Boxes. Preserve gear boxes in accordance with paragraph 7-7.

d. Main Rotor Blades.

(1) Preserve rotor blades in accordance with paragraph 7-5.

(2) Pack blades in main rotor blade crate (FO-4) or reusable shipping container. If no container is available, place cushioning (C-12) under, between, and over blades. Secure blades to floor or carrier with nylon straps.

Main Rotor Hub. Preserve main rotor hub in accordance with paragraph 7-12.

f. Main Rotor Mast and Swashplate Assembly. Preserve main rotor mast and swashplate assembly in accordance with paragraph 7-13.

Tail Rotor Blades. Preserve tail rotor blades in accordance with paragraph 7-14.

h. Synchronized Elevators. Preserve synchronized elevators in accordance with paragraph 7-16.

i. Tailboom.

(1) If removed, treat tailboom in accordance with paragraph 7-17.

(2) Mount 3 to 5 tailbooms on aft end of carrier, using one set of tailboom shipping racks.

l Landing Gear. Preserve landing gear in accordance with paragraph 7-20. Secure ground handling wheels in helicopter cargo compartment.

k. Airframe. Prepare airframe in accordance with paragraphs 7-21 and 7-24.

1. Battery. Preserve battery in accordance with paragraph 7-9.

4-5 1 MARKING.

Marking helicopter and components in accordance with paragraph 7-22 through 7-25.

4-6. LOADING. (figure 4-1).

a. Secure to the floor of the carrier six 2 x 10's, 9 feet 6 inches long. Place three boards adjacent to each other across carrier. These support aft skid saddles. Place remaining boards under forward skid saddles. Protect skid tubes with 1/2-inch felt.

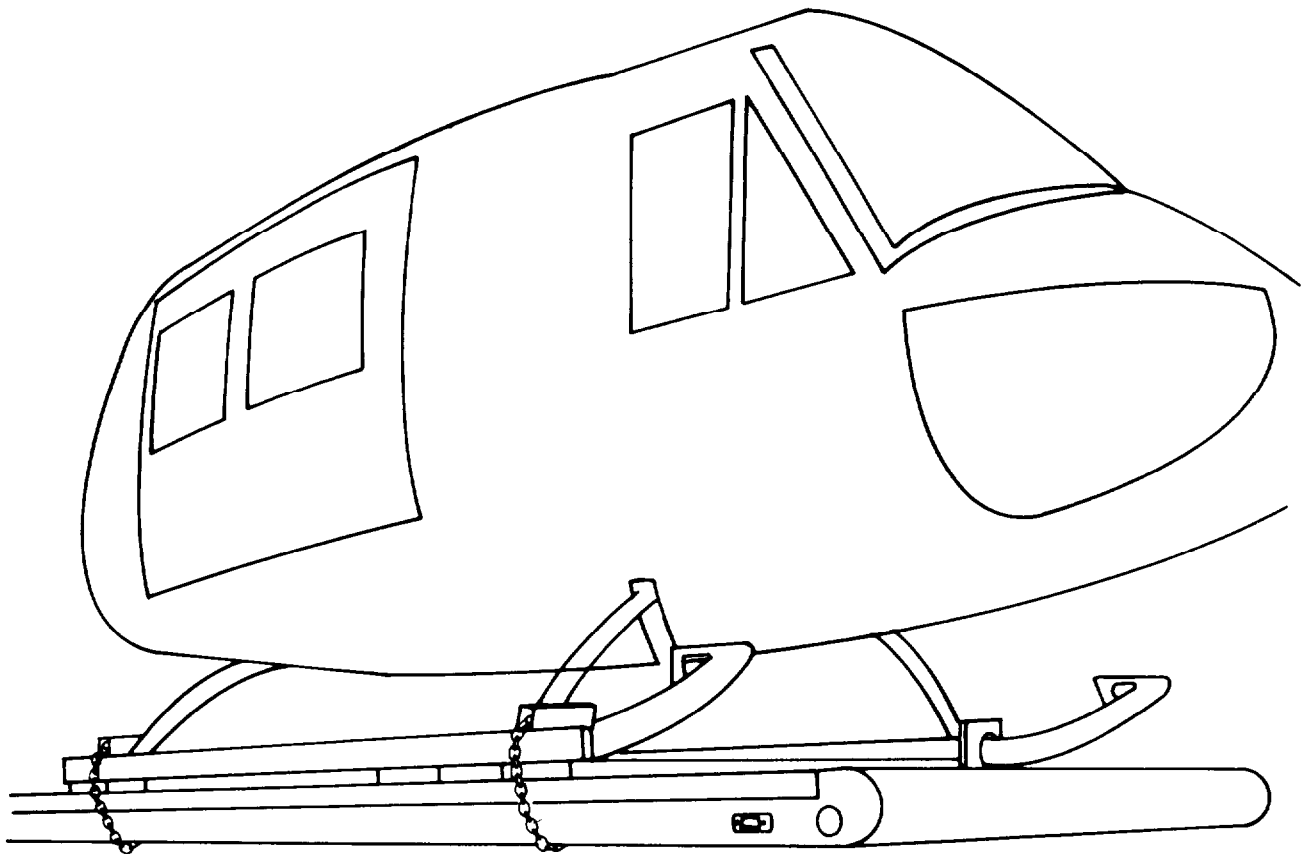

Figure 4-1. Shipment of UH-1 Helicopters by Truck.

b. Hoist helicopter to carrier by securing hoist hook to ring of transmission plate. If tailboom is removed, secure ballast to aft end of helicopter to compensate for changed center of balance. Load helicopters nose first.

c. Install one set of fuselage truck shipping supports over skid tubes forward and aft of skid saddles.

d. Place a 4 x 4 along exterior of each skid tube. Secure to 2 x 10's to prevent lateral movement during shipment.

e. If removed, mount tailboom(s) on aft end of carrier using one set of tailboom shipping racks.

4-7. TIEDOWN.

a. Secure landing gear skid tubes to carrier bed with chains mounted over shipping supports (figure 4-1).

b. Tie down fuselage in accordance with paragraph 2-13.

c. Secure tailbooms to carrier with metal chains or rope mounted over shipping racks.

CHAPTER 5

CRATED SHIPMENT

This chapter is not applicable to the UH-1 and EH-1X aircraft. █

CHAPTER 6

TACTICAL SHIPMENT OF UH-1/EH-1

SECTION 1. GENERAL

6-0. INTRODUCTION.

a. The concept of tactical aircraft shipments assumes expediency. Helicopters must be ready to perform their mission immediately after delivery; thus, little or no disassembly is implied. This, coupled with the quickest method of shipment, the cargo plane, suggests the Air Force C-5, the C-141, or the C-130 as the prime carriers. Depending upon the time frame and the number of helicopters involved, barge or cargo vessel could be employed where some disassembly might be acceptable to permit a greater cargo density.

b. Considering the mission of the EH-IX helicopter and reviewing table 2-2, it is recommended that the EH-IX be shipped only in C5 aircraft in accordance with paragraphs 2-7 and 6-13.

c. For all other modes of transportation, the EH-1X shall be disassembled in accordance with the following manuals (as applicable) and shipped as UH-1H helicopters.

(1) TM 55-1720-210-10

(2) TM 33-1520-210-23

(3) TM 32-5865-007- 10

(4) TM 32-5865-007-20 & P

d. The EH-IX helicopter shall be prepared in accordance with, TM 55-15820-210-23 and this manual.

e. Remove the EH-1X operator seat and rails in accordance with TM 55-1520-210-23.

f. For tools, refer to TM 55-1520-210-23/-23P.

SECTION II. MILITARY CARGO PLANES

6-1. C-5.

The Air Force C-5 is the largest of available cargo aircraft. Its cargo compartment measures 1448 inches long, 228 inches wide, and 162 inches high. Restraint criteria are: 3G forward, 1½ aft, 2G vertical, and 1½G lateral.

6-2. C-141.

Its cargo compartment is 1019 inches long, 111 inches wide (allows six inches of safety clearance between cargo and side walls) and 109 inches high. Restraint criteria are: 3G forward, 1 1/2G aft, 2G vertical, and 1 1/2G lateral.

6-3. C-130.

Dimensions of the C-130 cargo compartment are 492 inches long, 119 inches wide, and 108 inches high. Restraint criteria are 3G forward, 1 1/2 aft, 2G vertical, and 1 1/2G lateral.

6-6. AIR FORCE CREWS WILL:

- a. Advise and assist Army loading teams.
- b. Prepare the cargo plane for loading and unloading.
- c. Rig and operate loading aids organic to the aircraft.
- d. Designate the location of the helicopters.
- e. Determine restraint locations.
- f. Provide tiedown devices.
- g. Inspect for tiedown adequacy.

SECTION IV. FUNCTIONS OF ARMY LOADING TEAM

6-7. COORDINATION.

The Army installation preparing and loading helicopters must coordinate with Military Airlift Command (MAC) to be ready to park, refuel, and load when the MAC cargo aircraft arrives. All concerned must know how many of which series aircraft are being shipped and what model of cargo aircraft is requested to plan disassembly and obtain proper handling equipment, shoring, and cushioning.

6-8. ARMY LOADING TEAM IS EXPECTED TO:

- a. Prepare helicopters for shipment.
- b. Load, secure, and unload helicopters.
- c. Prepare manifest itemizing disassembled components stowed within helicopter as part of fuselage package.

WARNING

Computation of center of gravity (CG) must be exact. Predetermined CG or estimated weights may cause aircraft instability jeopardizing cargo and crew.

- d. Mark fuselage CG on side of fuselage package. Similarly mark major components not stored with helicopter. Verify and record shipping weights of each component on manifest.
- e. Furnish lumber and construct extensions to aircraft loading ramp.
- f. Furnish, rig, and operate auxiliary loading devices not a part of cargo aircraft.
- g. Furnish and operate auxiliary lights necessary for night loading.
- h. Furnish cargo aircraft commander DD Form 1387-2 listing all dangerous materials (defined by TM 38-250/AFM 71-4) shipped with or within helicopter (see paragraph 7-25).

SECTION III. FUNCTIONS OF CARGO AIRCRAFT CREW

6-4. RESPONSIBILITY.

Deciding when an Air Force aircraft is safe to fly is a responsibility of the aircraft commander. Determining aircraft weight, balance, and tiedown restraints are functions of the cargo aircraft loadmaster.

6-5. MOVEMENT OF HELICOPTERS.

Helicopters are loaded, secured, tied down, and unloaded by unit personnel with technical advice and assistance provided by the cargo aircraft loadmaster.

1. Be prepared to demonstrate for cargo aircraft commander that components stowed within helicopter are packaged correctly and secured in accordance with Air Force restraint requirements.

SECTION V. PREPARING THE CARGO AIRCRAFT

6-9. Cargo aircraft are prepared for loading by Air Force crew assisted by Army loading team. Army personnel construct necessary ramp extensions to change angle of approach to cargo aircraft. This prevents skid tubes from scraping the ground or gouging the ramp. Figure 2-5 shows a ramp extension for a C-141. Retain lumber used in ramp extensions for use in unloading.

SECTION VI. LOADING

6-10. GENERAL.

WARNING

Test all helicopters with purged fuel systems for dangerous fuel vapors immediately prior to loading in cargo aircraft. Test with a combustible gas indicator. If a dangerous level of fuel vapors exists, repurge until a safe reading is obtained. To avoid emergency purging, check for dangerous fuel vapors periodically prior to loading.

WARNING

Do not use modified ground handling wheels (figure 2-9) on the EH-IX helicopter. The EH-IX exceeds the weight limit for the single wheel.

CAUTION

Carry at least one set of ground handling wheels, if used, in the cargo aircraft to ensure their availability at the unloading site. If the tailboom is removed and dolly wheels installed under forward cross tubes. Carry a set of dolly wheels as well. Check tires for proper inflation.

CAUTION

Do not abuse ground handling wheels (particularly the single wheel configuration) by running over planks or other debris. These are likely to blow out tires or strain parts of handling wheel supports. When ramp extensions are made of nominal two inch lumber, reduce the bump at the ends by adding small pieces of wood or cutting the ends to make a gradual slope. This also applies to shoring used on cargo aircraft floor to prevent damage from dolly wheels.

TM 55-1520-242-S

a. Install dolly wheels and ground handling wheels (figure 2-6) whenever it is necessary to move the helicopter short distances or to load with tailboom removed. These wheels are not used when the helicopter is secured to a 463L pallet.

b. To install or remove dolly wheels, jack helicopter with two ten-ton jacks, type A-6 or equivalent. Do not use crow bars or Johnson bars to install wheels, as these may damage skid landing gears. Use 2x12 inch dunnage to protect cargo aircraft floor when jacks are used. If only one jack is used, exercise caution to prevent helicopter from being forced against cargo aircraft side or other cargo within aircraft.

c. When helicopter starts up cargo aircraft ramp, nose first, the tail skid will drag (unless using piggy-back or side-saddle kit). The loading crew must be prepared to lift tail to prevent damage. Loading tail first should be done cautiously in the C-5, and attempted only from a K-loader in the C-141 and C-130.

d. To control tailboom, tie or loop nylon tiedown straps around tail skid. Let ends hang so that three men can restrain each end. These men should be heavy enough to hold the tail down until it clears the critical area. They should not trail behind the helicopter or the strap could slip off the end of the tail skid.

e. When ground handling wheels reach approximately two feet below cargo aircraft ramp hinge, lay a sheet of 1 1/2 x 4 foot aluminum in the path of the approaching wheels. This will prevent gouging ramp or cargo floor with rough end of helicopter skid tube.

NOTE

Aluminum sheeting is preferred for protecting cargo aircraft floor and ramp. If not available, substitute plywood, fiberglass or plastic. It should not be more than 1/8 or 3/16 inch thick so that skid landing gear will not hang up on it.

NOTE

Use padding in all instances of tiedown and tow from cross tubes where there would otherwise be metal to metal contact.

6-11. LOADING A C-141 CARGO AIRCRAFT.

a. Figure 6-1 is the preferred load plan for two helicopters with tailboom installed, however, if no K-loader is available both helicopters can be loaded nose first. This results in a very tight load.

NOTE

A flat bed truck is not an acceptable substitute for a K-loader when loading the C-141.

(1) Preferred Method (K-Loader).

(a) Disassemble in accordance with Table 2-1.

(b) Remove or lower control rods which project above cabin.

(c) Install modified ground handling wheels or Loading and Positioning Device (after placement on the K-loader).

(d) Hoist helicopter, nose forward, on K-loader with a five ton crane attached to transmission adapter cover plate. Secure in place with two 5,000 pound tiedown straps to prevent movement during loading. When K-Loader is adjacent to ramp, remove tiedown straps.

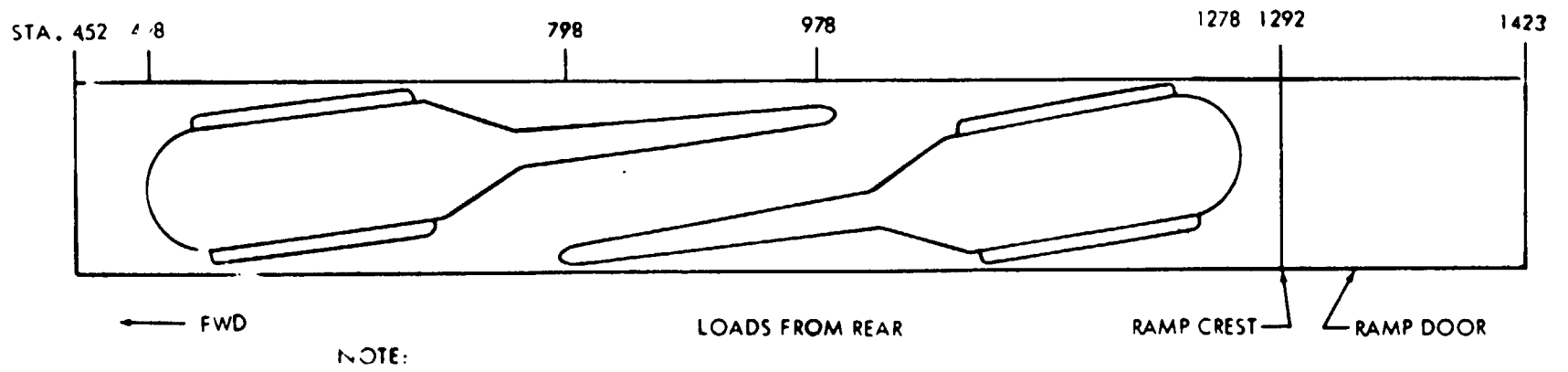

Figure 6-1. C-141 Cargo Aircraft Loading Diagram.

CAUTION

Place thin strips of aluminum or plywood below skids to prevent them from touching the cargo aircraft floor.

(e) Push first helicopter into cargo aircraft until helicopter nose reaches station 498 in Mdl.A or station 338 in Mdl.B. Remove K-loader.

CAUTION

Do not place blade tips forward of station 498 in Mdl.A or station 338 in Mdl.B or they may be damaged by personnel walking on them. Take extreme care not to damage blade tips, drain tubes, or navigation lights when stowing rotor blades.

(f) Stow main rotor blades directly under fuselage. Secure with two 5,000 pound tiedown straps, cushioned to prevent abrasion, placed across the tip and root ends, and one strap to prevent forward motion.

(g) Load second helicopter, tail first, on K-loader.

(h) Push second helicopter into C-141 until its nose reaches station 1278 in Mdl.A or station 1396 in Mdl.B.

(i) Secure helicopters to cargo aircraft floor in accordance with figure 2-10.

(2) Alternate Method.

(a) Install modified ground handling wheels (figure 2-9) and dolly wheels (figure 2-6) or Loading and Positioning device.

(b) Make towing bridle by looping 10,000 pound tiedown chain around each end of padded forward cross tubes. Use at least two chains on each side. Bring ends together to form a triangular bridle.

(c) Station one man on each side of ramp in front of helicopter to act as signalman and check side clearance. Station six men at tail end to control tailboom and keep it from hitting cargo aircraft.

(d) Extend ramp by means of shoring so that the ascent may be made without the skid "hanging up" before the wheels reach the ramp.

CAUTION

Place thin strips of aluminum or plywood below skids to prevent skids from touching the cargo aircraft floor.

(e) Attach cargo aircraft winch cable to ends of towing bridle. As slack is taken up in cable and helicopter begins to move, lift up tail to keep fuselage horizontal until landing gear is completely on ramp.

CAUTION

Do not attempt to load a UH-1 tail first using the ramp. Clearance cannot be maintained between tail and ceiling.

(f) Move the first helicopter within two inches of baggage rack and angled between the sides of the cargo aircraft.

NOTE

Make as great an angle as possible or the second helicopter will not fit far enough forward to be contained in the cargo plane.

(g) Use blocks as required under forward portion of the skid tubes to bring the tail down below the ceiling.

(h) Winch second helicopter carefully into position alongside the first one. The nose should be at station 820 in Mdl.A or 938 in Mdl.B.

(i) Secure in position in accordance with figure 2-10.

6-12. LOADING A C-130 CARGO AIRCRAFT.

One UH-1/EH-1 helicopter may be loaded in a C-130 cargo aircraft using the same procedures as for a C-141, method 1 or method 2; however, because only one can be loaded, angling the UH-1 within the C-130 is not necessary. The air transportability shipping skid must be used on UH-1H/V models to reduce their height.

6-13. LOADING A C-5 CARGO AIRCRAFT.

a. General. Seven UH-1H/V/EH-1H and eight UH-1B/M helicopters may be loaded with no disassembly.

b. Loading from a K-Loader or Flat-Bed Truck.

(1) Single-handling wheels or the Loading and Positioning Device will be used on all helicopters next to the cargo compartment wall.

WARNING

Stand clear of modified ground handling wheels while in use. They are loaded to capacity.

(2) Using a shackle adapter (FO-5) or a clevis attached to mast nut, hoist the helicopter aboard the K-loader or flat-bed truck with a crane of 10,000 pound capacity. Secure helicopter to conveyance with 5,000 pound tiedown straps.

(3) Move conveyance against C-5 ramp to obtain a continuous surface between cargo aircraft floor and vehicle. Release tiedown straps.

(4) A minimum of six men constitute the loading team. Position one man on each side to check side and overhead clearance. Position two men at tail to move and/or guide helicopter into cargo aircraft. Two men are to control main rotor blades by means of drop lines from rotor blade tips.

(5) Place aluminum or plywood sheeting under helicopter skids on the C-5 floor.

(6) Move helicopter into tiedown position and place 1/2 inch plywood (minimum) under skids. Remove handling wheels.

c. Loading Using the Ramp.

(1) Eight people are needed for the Army loading team. One person is required at rotor blade extremities to ensure clearance as the helicopter ascends the ramp. This is to prevent blade from striking the ramp and/or hitting cargo plane ceiling. One person should be on each side of ramp ahead of helicopter to check side clearance and position aluminum or plywood sheeting under skids as the helicopter progresses. Four people at the tail will guide the helicopter as it proceeds up ramp and into cargo plane.

(2) Use single handling wheels or Loading and Positioning Device so as to be able to cargo aircraft walls.

NOTE

A set of handling wheels or a L & P Device must accompany the cargo plane to destination so it may retain capability to off-load when necessary.

(3) Make a towing bridle by looping a 10,000 pound chain around each end of the nearest cross tube. Two chains are required on each side. Bring ends together to form a triangular bridle with winch hook UP.

(4) Pull helicopter up ramp using cargo winch and snatch blocks as required.

(5) As helicopter ascends ramp, lift tailboom to keep it from dragging.

(6) When helicopter reaches ramp crest, restrain vertical stabilizer from hitting cargo plane ceiling.

(7) When helicopter reaches horizontal section of cargo floor release tow cable and manually maneuver helicopter into tiedown position.

CAUTION

Rotational movement of main rotor blades will produce a corresponding movement of tail rotor blades.

(8) Place plywood under the skids before tiedown.

(9) Do not position helicopters so closely that personnel cannot maneuver between them.

SECTION VII. TIEDOWN

6-14. UH-1 TIEDOWN.

NOTE

Because of mission equipment installed in the cabin, only a single lateral tiedown beam (figure 2-2) may be used on the EH-1X.

a. Tiedown instructions are given on figure 2-10. Tiedowns 2,3,4 and 6 are 10,000 pound tiedown chains across tiedown beams to rings on cargo aircraft floor which are inboard of fuselage and forward/aft of support beams. carefully hand-tighten all tiedown devices.

CAUTION

Do not apply tension to straps attached to helicopter tailboom. Because of the long lever arm, a slight stress can be multiplied to the point of structural damage to helicopter.

b. Restrain blades to cargo plane floor tiedown rings or skid tips with a force of no more than 395 pounds and tip deflection of no more than 53 inches. If tiedown straps are used rather than tip restraining straps, ensure that the blade surface is padded and that the strap is not contacting the blade trim tab.

SECTION VIII. OFFLOADING

6-15. GENERAL.

Offloading procedures are generally the reverse of Loading. Rate of descent must be controlled as the helicopter rolls down the inclined floor and ramp, Perform the following before unloading.

- a. Extend cargo aircraft loading ramp with 2" x 8" x 10 or 12 foot boards supported by shorter pieces underneath. Shoring used in loading should have been shipped with helicopter.
- b. Position one man at each side of ramp to relay signals to and from aircraft loadmaster.
- c. Position four men at helicopter tail to guide tail and prevent it from striking aircraft or ground as it descends ramp. Secure a nylon web strap around tail skid to enable them to control tail more effectively.
- d. Install ground handling wheels.
- e. Move helicopter to inclined floor or ramp.

CAUTION

Ensure that open portion of winch hook is UP,
or cargo floor may be damaged.

- f. Make towing bridle by looping 10,000 pound tiedown chains around each padded crosstube junction with the skid. Use two chains on each side. Use a third chain to join the chains together thus forming a triangular bridle.

6-16. OFFLOADING BY WINCH.

- a. Connect the winch to the bridle.
- b. Slowly allow the helicopter to roll down the ramp while Army personnel maintain its direction and weight on the wheels by means of tail elevation.
- c. When on the ground and clear of the cargo plane, remove the winch hook and bridle.

6-17. OFFLOADING BY MANPOWER.

- a. Attach two 5,000 pound tiedown devices to the bridle apex.
- b. Attach movable hooks of each strap to a tiedown fitting so that the quick-locking device may be shut instantly.
- c. Position two men at the end of each strap.
- d. Place four men at helicopter tail to guide and control tailboom as helicopter is offloaded.
- e. Pull helicopter to start it down the incline. At the same time pry out on restraining straps.

NOTE

Men controlling the restraining straps should be prepared to shut quick-locking device at first sign of trouble.

f. Allow helicopter to roll down ramp and along the ground until it clears tile cargo plane.

g. Remove the bridle and straps.

SECTION IX. BARGE SHIPMENT

6-18. GENERAL.

Though movement of helicopters has been successfully achieved by certain types of barges, it certainly cannot be considered expedient. There are two barge systems:

a. Lash Lighter. This is a relatively thin-skinned double-hulled box with a watertight hatch cover. It may be of steel or fiberglass construction. The inner skin is not water-tight. The Lighter can carry as much as 370 long ton (LT) of cargo at a draft of just over eight feet; however, density of helicopter loads would not cause Lighter to draw more than five or six feet. Its dimensions are: 61.5 feet long, 29.5 feet wide, and 11.7 feet high. It will accommodate six UH-1 helicopter without main rotor blades, one tail rotor blade, elevators, and whip antennas and should hold four UH-1/EH-1's with only blades removed (figure 6-2). Removal will be in accordance with paragraph 7-11. Because helicopter height exceeds that available in the barge with the hatch covers on, "standoffs" must be used when positioning the hatch covers. Blades will be placed in blade containers which will be positioned under the tailbooms. Other removed components will be packed, cushioned, and secured within the helicopters.

b. Seabee Barge. Water tight and double-hulled, the Seabee Barge is the same width though half the length of the standard US commercial river barge. Its dimensions are: 90 feet long, 30.2 feet wide, and 14.5 feet high. It will carry 834 LT at a draft of 10.5 feet or 1.75 feet when empty. This barge will hold seven helicopters without disassembly and nine with horizontal stabilizers removed (figure 6-3).

c. Disassembly and preservation of UH-1/EH-1's for lash barge shipment will be in accordance with that for vessel or air shipment. Where space permits, blade containers will be used, otherwise, blades will be cushioned and placed on the barge deck then the helicopters placed over them.

d. A further application of the Seabee concept is that of stowing complete helicopters (with blades) in place of barges on the lower deck of the vessel. It has been demonstrated that helicopters may be landed on the top deck for subsequent stowage below. Either the main

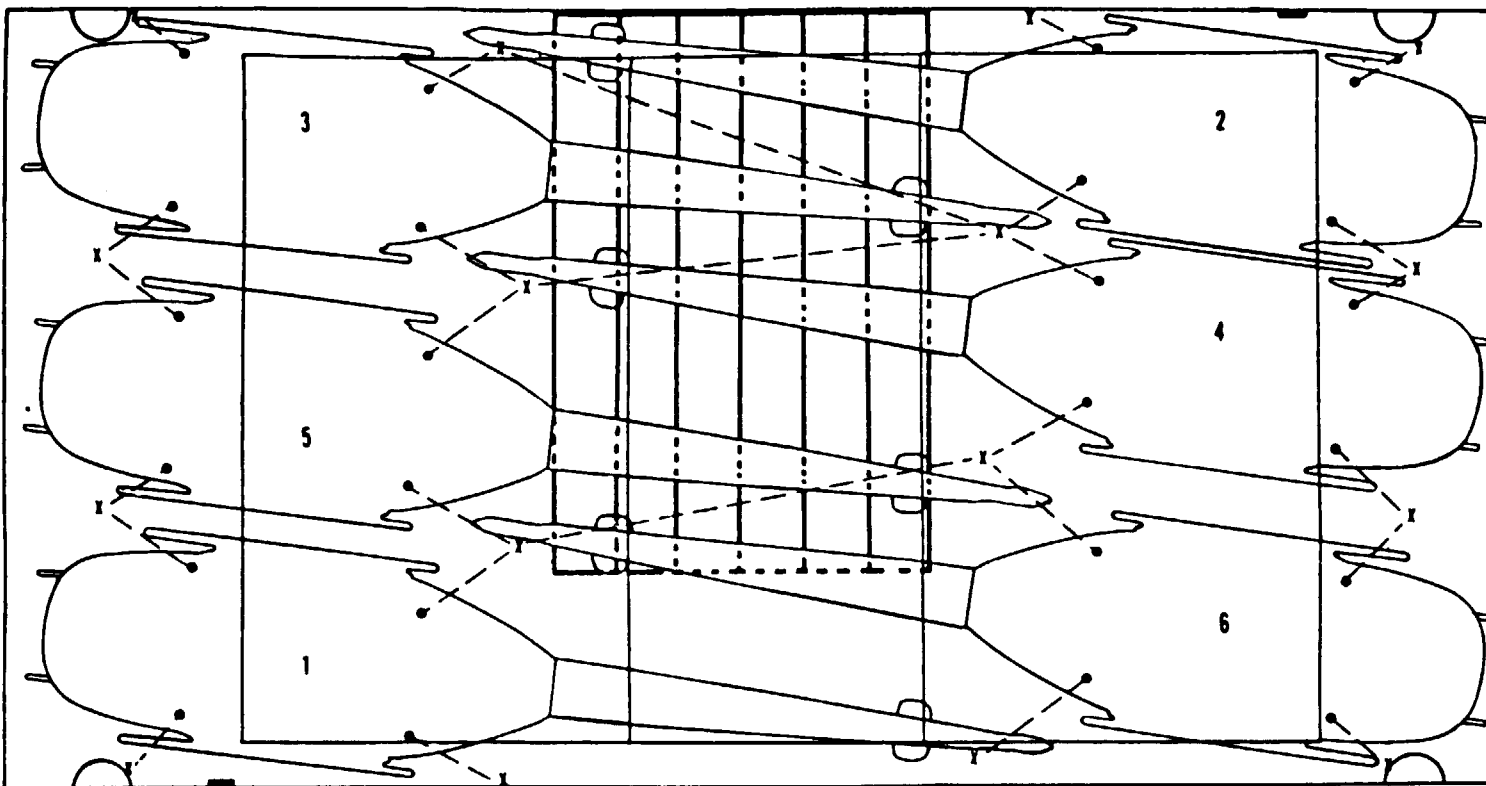

LEGEND

- x TIEDOWN FITTING IN LIGHTER
- TIEDOWN FITTING ON HELICOPTER FUSELAGE
- TIEDOWN DEVICE OR CABLE

Figure 6-2. Loading Sequence and Tiedown Diagram for Six UH-1H/M/V Helicopters in a LASH Lighter.

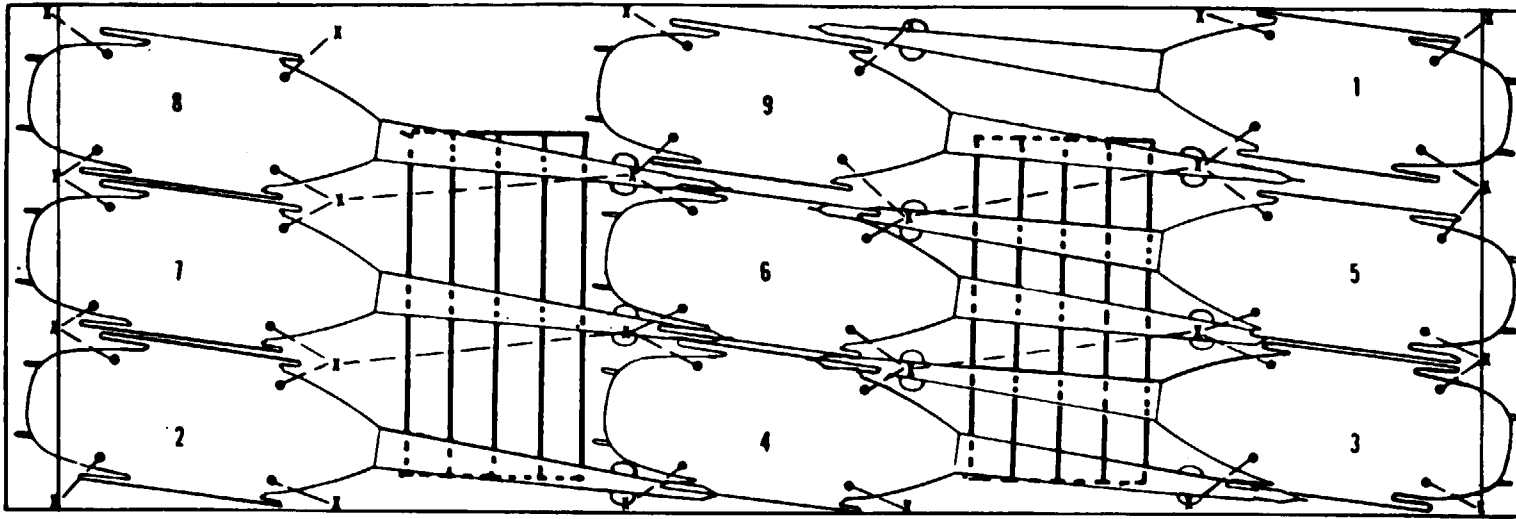

LEGEND

- x TIEDOWN FITTING IN BARGE
- TIEDOWN FITTING ON HELICOPTER FUSELAGE
- TIEDOWN DEVICE OR CABLE

Figure 6-3. Loading Sequence and Tiedown Diagram for Nine UH-1H/M/V Helicopters in a SEABEE Barge.

or lower deck of the Seabee vessel offers 45,000 square feet of protected storage with an overhead height of 19 feet three inches on the lower deck. Loading may be accomplished either by positioning the helicopter on the stern elevator or by flying them directly onto the top deck of the vessel. From there they may be rolled aft to the elevator to be positioned below.

e. Tiedown. Because there are no floor tiedown inserts on the Lash barge, these will have to be welded to the floor as required. The Seabee barge has a limited number, and others will have to be added for helicopter shipment. Tiedown pattern will be as shown in figures 6-2 and 6-3.

f. Further information may be found in Chapter 5 of TM 55-1520-400-14, Marine Transport of U S Army Helicopter.

CHAPTER 7

PREPARATION FOR SHIPMENT

SECTION L CLEANING

7-1. GENERAL.

Clean helicopter before preparing it for shipment. Residues from exhaust gases, dirt, or contamination of any kind accelerate corrosion. Procedures for cleaning the fuselage area and cleaning the removed components refer to TM 55-1520-210-23-1.

7-2 INTERIOR.

- a. Thoroughly vacuum aircraft interior.
- b. Clean upholstery as necessary with mild soap (C-24) and water.

WARNING

Although solvent (C-8) is safe and non-flammable, use only with adequate ventilation. Avoid prolonged breathing of vapors. Do not use near open flames or heat, since its decomposition products are toxic. Wear rubber gloves and avoid contact with skin.

- c. To remove grease and oil spots, use solvent (C-8). Wipe dry with a clean cloth.

7-3. EXTERIOR.

CAUTION

The UH-1 C/M contains bearings which are sensitive to petroleum compounds. Do not use any type of solvent to clean rotor head or mast assemblies.

Clean exterior structure with a mixture of one part cleaning compound (C-7) and time to seven parts water. Use stronger mixture for exhaust outlet areas and other very dirty surfaces. Wash a small area at a time, rinsing thoroughly with water under pressure. If allowed to dry, or if not completely rinsed off, C-7 could harm painted finishes.

NOTE

A soft brush (C-6) may be used to apply compound.

TM 55-1520-242-S

7-4 1 PLEXIGLASS.

a. Clean all transparent plastics with large quantities of mild soap (C-24) and water.

CAUTION

Do not use compounds containing any abrasive material, or solutions containing esters, ketones, aromatic hydrocarbons or chlorinated carbons. Avoid excessive scrubbing of plastic panels.

b. Gently free all caked mud and dirt with finger pads. Do not use sponges or coarse cloths. Rinse area continuously while removing mud.

c* Remove grease and oil with aliphatic naphtha (C-19).

d. Allow surfaces to drip dry.

e. Remove minor scratches with a suitable plastic cleaner (C-9) or a light coat of high quality wax.

7-5. ROTOR BLADES.

Wash rotor blades with mild soap (C-24) and water.

7-6. TREATMENT OF ALUMINUM AND MAGNESIUM ALLOY CORROSION.

a. Treat aluminum and magnesium alloy corrosion in accordance with TM 55-1500-204-25/1, Chapter 3, Section II.

b. Apply protective paint finish in accordance with TB 746-93-2 to affected area immediately after chemical treatment dries.

SECTION II. PRESERVATION AND PACKAGING

7-7. ENGINE AND GEAR BOXES.

a. Free engine, cowling screens, particle separator, and FOD screen of any foreign material. Clean as required in accordance with the appropriate technical manual.

b. Add corrosion preventive concentrate (C-5 or equivalent) to engine oil system and power train boxes in accordance with TB 55-9150-200-24. Flushing engine oil system is not required during engine activation.

c. Check oil level; service lubrication system as necessary.

7-2 Change 1

CAUTION

Do not exceed maximum operating limitations for engine ground runup.

d. Ground runup engine to complete internal preservation of transmission and gearboxes. If engine has not been started within 24 hours, start in accordance with appropriate maintenance manual. Operate for approximately 10 minutes at a minimum N_2 of 5500. Restrict operation at flight idle to two minutes at each period. Check all instruments for normal operation and insure that engine temperature has stabilized. Shut down engine.

e. Disconnect 28-vdc power supply from ignition unit.

f. Remove fuel inlet and pump discharge strainers and servo supply filter. Clean with drycleaning solvent (C-15); reinstall.

g. Preserve compressor blades with corrosion preventive compound (C-26) as follows:

CAUTION

Do not operate starter in excess of operating limits: three runs of 40 seconds each, maximum, during any 60 minute period. Three minutes cooling time between starts is required. Do not engage starter until engine comes to complete stop.

(1) Motor engine with starter to starting RPM. With throttle closed, apply C-26 as engine coasts down.

(2) Hold C-26 aerosol can and snorkel tube so that tube projects into areas between inlet housing struts. Direct jet stream between any two inlet guide vanes onto rotating compressor blades. Move jet stream from base to tip of blades, coating as much of blades as possible.

(3) Apply jet stream for 30 seconds.

h. Disconnect main fuel hose from main fuel manifold (T53-L-11 engines) or flow divider assembly (T53-L-13 engines) and starting fuel hose from starting fuel manifold. Install temporary line on end of hoses to allow drainage into suitable container.

i. Attach hose from lubricating oil (C-18) source to fuel control inlet fitting.

TM 55-1520-242-S

j. With throttle in FLIGHT-IDLE, motor engine with starter to pump oil into fuel system. Actuate starting fuel solenoid, if installed, while motoring. Continue motoring until oil drains from starting and main fuel hoses.

k. Disconnect lubricating oil hose from fuel control and connect fuel inlet hose assembly.

l. Remove temporary lines from fuel hoses and connect main fuel hose to main fuel manifold (T53-L-11 engines) or flow divider (T53-L-13 engines). Connect starting fuel hose to starting fuel manifold.

m. Reconnect 28-vdc power supply to ignition unit. Lockwire connector.

n. Encircle engine with a narrow strip of barrier material (C-2) secured with tape (C-25) to cover gap between bleed band and compressor housing.

o. Remove fuel filter element; clean; dip in oil (C-18); reinstall.

p. Visually inspect entire engine. Plug all holes, cap all ports, and ensure that external parts are complete and properly torqued. Install applicable covers.

q. Cover bare metal, including internal and external threads, with a film of corrosion preventive compound (C-n).

r. Record date and extent of preservation on aircraft historical records. Annotate records that corrosion preventive concentrate has been added to engine oil system and that flushing is not required.

Tag controls with: ENGINE PRESERVED. FUEL CONTROL PRESERVED WITH MIL-L-6081 LUBRICATING OIL. FLUSH WITH STANDARD FUEL BEFORE PLACING IN SERVICE.

7-8. FUEL TANKS.

a. If aircraft must be fueled for fly-off at destination, adjust fuel level to a maximum of 3/4 full or 150 gallons per tank, whichever is less (minimum fuel level is not a shipping concern). Tag fuel caps with number of gallons and type of fuel in each tank. Make entry in log book showing that aircraft is fueled, with date and activity shown.

- b. If tanks are to be purged, proceed as follows:

WARNING

To ensure personnel and equipment safety, observe the following precautions: Properly ground aircraft and all equipment used, including defueling equipment, work stands, purging equipment, and powered or pneumatic tools. Equip work stands with a personnel static discharge plate of copper or zinc plate so that personnel can contact plate before contacting aircraft. Do not drain fuel tanks near the end of the work day and allow to stand "empty" overnight. Residue fuel drains down tank sides, forming puddles. During the night, fuel from these puddles evaporates into the air. If a critical fuel-air ratio develops, a spark could set off an explosion. Therefore, avoid a time lapse between draining and purging.

- (1) Drain fuel tanks.
- (2) Flush tanks with 5 gallons of diesel fuel (C-14), and drain through gravity fuel valve.
- (3) Fill fuel tanks with diesel fuel (C-14). Allow it to remain in tanks overnight or for approximately 10 hours.
- (4) Drain diesel fuel from tanks.
- (5) Test tanks with a combustible gas indicator. If a dangerous level of fuel vapors exists, discard drained diesel fuel. Repurge as necessary until a safe reading is obtained.
- (6) Tag fuel cap with: "FUEL SYSTEM PRESERVED WITH DIESEL FUEL . NO FLUSHING REQUIRED."

7-9. BATTERY.

WARNING

Keep electrolyte from contacting clothing, skin, or eyes.

- a. Nickel-cadmium batteries contain an electrolyte composed of potassium hydroxide, a strong alkali which corrodes both aluminum and magnesium. A serviceable battery will not deteriorate if left standing for long periods whether wet or dry, charged or uncharged. Therefore, ship batteries fully charged and wet.

WARNING

Turn battery switch on panel OFF prior to working on battery.

b. Remove battery. Thoroughly clean battery exterior, quick disconnect plug, cables, carrier, and vent hoses with a solution of five ounces of boric acid crystals (C-4) dissolved in one gallon of water. Rinse with clean water. Allow to dry.

c. Reassemble parts and replace battery in aircraft battery carrier.

d. Use quick disconnect plug to open electrical system circuit. Cover ends of plug with barrier material (C-2), secured with tape (C-25). Secure disconnect cable and plug to airframe to prevent movement during transport.

7-10. STABILIZER BAR.

a. If stabilizer bar remains attached to aircraft, preserve as part of main rotor head.

b. If stabilizer bar is removed, treat as follows:

(1) Color code assembly.

(2) Remove stabilizer bar without separating stabilizer bar tube assembly from center frame assembly.

(3) Cushion stabilizer bar with C-12, wrap with barrier material (C-3), and secure with tape (C-25).

(4) Pack in stabilizer bar crate (FO-6).

7-11. MAIN ROTOR BLADES.

a. Removal.

(1) Main rotor hub with blades attached is accomplished in accordance with the applicable maintenance manual.

(2) Individual blades may be removed as follows:

(a) Rotate forward blade to ten o'clock position to provide secure footing for technician on fuselage.

(b) Using a crane with a padded sling or a forklift with a cushioned safety pallet, support blade so leading edge is straight.

(c) Perform steps a(2), a(3), and a(4) for UH-1B; steps a(2) through a(6) for UH-1C/M; and steps (1)(b), (1)(c), and (1)(d) for UH-1H/V of the appropriate -20 or -23 maintenance manual while observing all notes.

(d) Carefully lower blade and remove from sling or safety pallet.

(e) Immobilize main rotor head, place rubber blocks wrapped with barrier paper (C-3) between the rotor hub stops.

b. Apply preservative compound (C-n) sparingly to bolt holes in root end of blades and to all bare metal surfaces.

c. Wrap root end and that portion of blades which rests within container saddle with barrier material (C-2) and secure with tape (C-25) .

d. Secure blades in blade container (FO-4).

e. If blade containers are not available or if space is limited, cushion blades with polyethylene foam (C-12). Old blankets, pillows, used tires, etc., may be used, if necessary. Place cushioning under, between, and on top of blades, so that tiedown straps do not contact blades.

7-12. MAIN ROTOR HUB INSTALLATION.

a. If main rotor hub remains installed:

(1) Lightly coat blade retaining bolts and drag brace bolt, washers, nut, and shims with preservative (C-10). Replace in rotor hub grip exactly as removed. Wrap grips with barrier material (C-3), secured with tape (C-25).

(2) Leave damper assembly installed. Pad with cushioning (C-13). Secure pad to mast with tape (C-25).

(3) Install lock blocks (figure 7-1) on each side of rotor mast to immobilize main rotor head. Wedge blocks in place; secure with 1/2-inch wide steel banding.

(4) On the UH-1 C/M, place rubber blocks (C-23) between rotor hub and hub stops to immobilize main rotor hub.

b. If main rotor hub is removed:

(1) Coat splines with corrosion preventive (C-10). Wrap hub with cushioning (C-12).

(2) Secure in helicopter cargo compartment with nylon straps (figure 2-4).

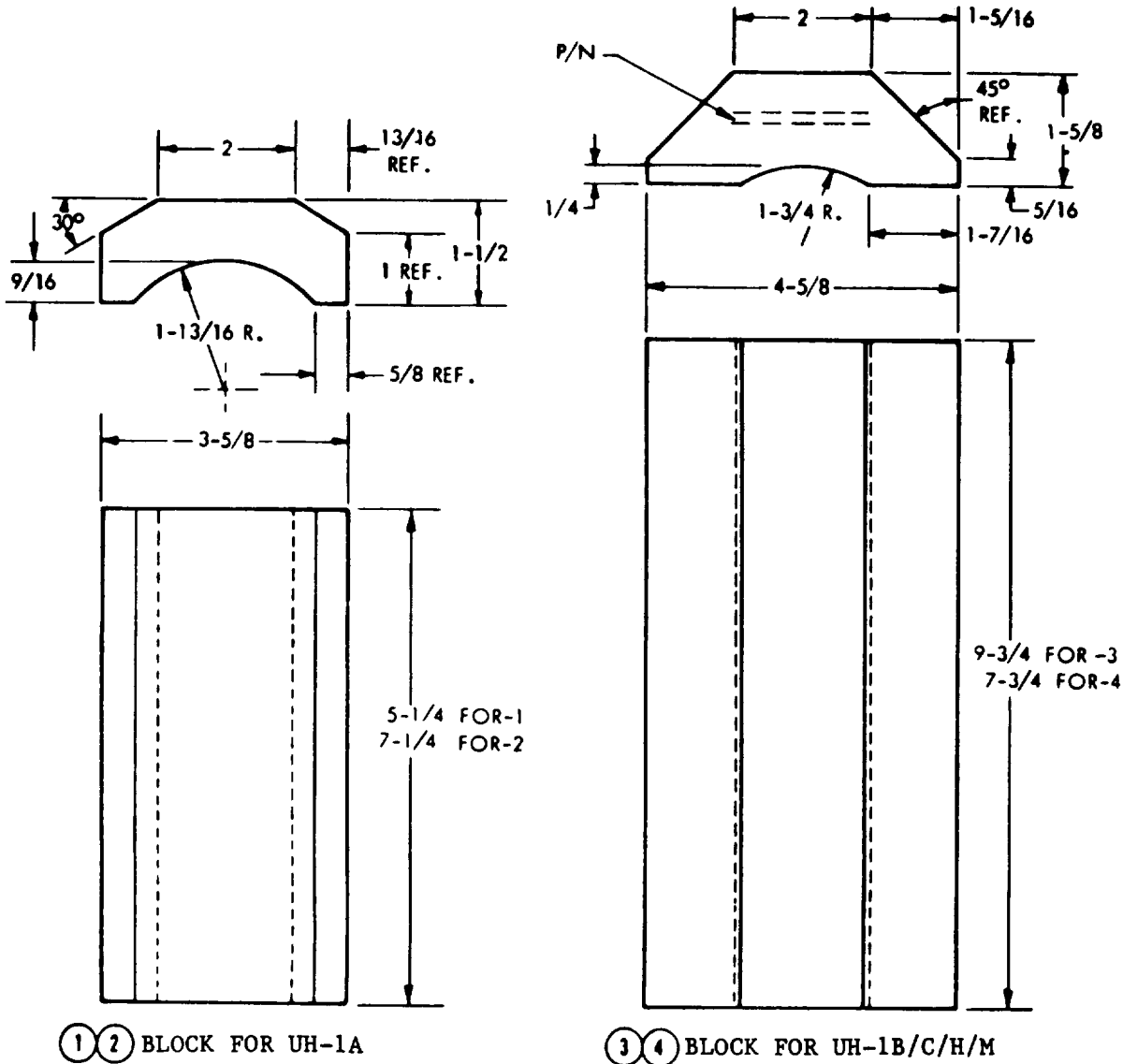

NOTE 1. WRAP ROTOR MAST WITH GRADE A BARRIER MATERIAL, INSERT BLOCKS ON EACH SIDE OF ROTOR MAST UNDERNEATH ROTOR HEAD AND WEDGE IN PLACE. AFTER INSTALLING, LOCK IN PLACE WITH 1/2 WIDE STEEL PACKING STRAP

NOTE 2. BLOCK -1 AND -4 SHORTENED TO FACILITATE INSTALLATION OF BLOCKS WITHOUT REMOVAL OF DAMPER ASSEMBLY.

4	1	BLOCK, SHORT	2 X 5 X 7-3/4	LUMBER*	
3	1	BLOCK, LONG	2 X 5 X 9-3/4	LUMBER*	
2	1	BLOCK, LONG	1-1/2 X 3-5/8 X 7-1/4	LUMBER*	
1	1	BLOCK, SHORT	1-1/2 X 3-5/8 X 5-1/4	LUMBER*	
ITEM NO.	QTY. REQD.	PART	DESCRIPTION	SPECIFICATION	NOTES

*MIL-C-104, GROUP II
AV-05-0204

Figure 7-1. Lock-Blocks for UH-1B/C/H/M/V and EH-1H.
7-8 Change 1

7-13. MAIN ROTOR MAST AND SWASHPLATE ASSEMBLY.

a. If assembly remains installed:

(1) Wrap entire main rotor head mast assembly and stabilizer bar (if installed) with barrier material (C-3) secured with tape (C-25).

(2) If necessary, lash cover snug with 1/8-inch nylon cord (C-21) and tape (C-25).

b. If assembly is removed:

(1) Coat splined area of main rotor mast and bare metal surfaces of swashplate assembly with corrosion preventive (C-10).

(2) Remove assembly.

(3) Cushion damper with C-13 and secure with tape (C-25).

(4) Wrap lower end of mast with barrier material (C-2), secured with tape (C-25).

(5) Wrap entire assembly with cushioning (C-12).

(6) Secure assembly to floor of helicopter cargo compartment .

7-14. TAIL ROTOR BLADES.

a. If tail rotor blade(s) are removed:

NOTE

If both blades are removed, color-code blades before removing.

(1) Lightly coat all bolt holes and bare metal surfaces with presevative (C-n).

(2) Wrap preserved area with barrier material (C-3) secured with tape (C-25).

(3) Cushion blades with C-12 and pack in a fiberboard box (c-16).

(4) Stow box in helicopter cargo compartment.

b. If tail rotor blade(s) are installed:

(1) Secure a pad of cushioning (C-12) (or pilot's seat cushion, or equivalent) between tail rotor blade and vertical fin.

(2) Wrap tape (C-25) around blade and fin to hold blade firmly, but not tightly enough to place undue strain on blade.

7-15. TAIL ROTOR ASSEMBLY.

- a. Apply a light coat of preservative (C-11) to all bare metal surfaces of tail rotor gearbox, tail rotor hub, and installed tail rotor blade(s).
- b. Wrap with barrier material (C-3) and secure with tape (C-25).

7-16. SYNCHRONIZED ELEVATORS (REMOVED).

- a. Coat attachment fittings with corrosion preventive (C-11). Cover preserved areas with barrier material (C-2), secured with tape (C-25).
- b. cushion elevators with (C-12). Pack in a fiberboard box (C-16).



If spoilers are mounted on upper surfaces of synchronized elevators (UH-1B), pack elevators so that spoilers are adjacent to exterior surfaces of packing box.

- c. secure box in helicopter cargo compartment with nylon straps.

7-17. TAILBOOM (REMOVED).

- a. Coat attachment points and hardware with corrosion preventive (C-11).
- b. If applicable, secure tailboom to side-saddle or piggy-back kit.
- c. If kits are not used transport tailboom on cushioning (C-12) or a well-cushioned tailboom rack.

7-18. ANTENNAS.

- a. Whip Antennas.
 - (1) Wrap threaded end of antenna with barrier material (C-3) secured with tape (C-25).
 - (2) Stow antenna in helicopter cabin area against back wall and secure with tape (C-25).
- b. ARC-102 & ARC-199 Antenna Standoffs.
 - (1) Wrap standoffs with barrier material (C-3) secured with tape (C-25).
 - (2) Pack in fiberboard box (C-16).
 - (3) Stow box in helicopter cargo compartment.

(4) Cover antenna feedthru opening with material (C-3) and tape.

c. ARC-102 Antenna.

(1) Coil antenna and wrap the barrier material.

(2) Secure coiled antenna to fuselage with tape (C-25).

d. Homing Antenna Elements (Wands).

(1) Wrap wands with barrier material (C-3).

(2) Pack in a fiberboard box (C-16).

(3) Secure box in helicopter cargo compartment.

e. ARC-199 Antenna.

(1) Separate antenna sections and wrap with barrier material (C-3) secured with tape.

(2) Stow antenna in helicopter cargo compartment.

7-18.1 WIRE STRIKE PROTECTION SYSTEM.

a. Place breakaway tip and attachment hardware in a plastic bag or other suitable container.

b. Stow in helicopter cabin area and secure with tape (C-25).

7-19. PLEXIGLASS.

Cover all plexiglass with barrier material (C-3) secured with tape (C-25).

NOTE

Do not apply tape to plexiglass

7-20. BARE METAL SURFACES.

Coat all unprotected bare metal surfaces with preservative (C-11).

7-21. FUSELAGE.

a. Group all technical manuals, handbooks, equipment log books, maintenance and historical records, first aid packs, fire extinguishers, headset microphones, clock, and magnetic compass.

(1) Wrap in barrier material (C-3) cushion as necessary with (C-13).

(2) Pack in fiberboard box (C-16) conspicuously marked to identify contents.

TM 55-1520-242-S

- d. Deenergize circuit breaker panels.
- e. Cage instruments, as necessary.
- f. Secure overhead instrument lights to overhead panel fixture with tape (C-25).
- g. Lock collective pitch control.
- h. Cover air intakes and exhaust with barrier material (C-3) secured with tape (C-25).
- i. Remove external rear view mirror. Stow in baggage compartment in brackets provided.
- j. Retract landing lights.
- k. Pad all exterior lights with cushioning (C-13), secured with tape (C-25).
- l. Firmly secure removed components stowed in helicopter cargo compartment with 1/4-inch manilla rope (C-21).
- m. Secure and lock all doors.
- n. Connect forward and aft door handles with steel banding.

(1) Wrap steel banding once around spindle or shaft of forward handle.

(2) Clamp with a seal as close as possible to shaft.

NOTE

Free end of steel banding, to be used later, should be approximately one foot long.

(3) Stretch banding to aft door handle, wrap around shaft or spindle and bring forward.

(4) Join forward and aft ends together. Make loop tight around forward handle so that banding cannot be slipped off.

CAUTION

Ensure that banding between handles is not stretched so tightly as to put strain on handles.

(5) Install heat shrink film protective covering in accordance with Appendix G.

7.21.1 AN/ASC-15A(V) 3 AND 4 INSTALLATION KIT

NOTE

Install (C-27) fiberboard box inside (C-28) before stowing equipment in fiberboard box.

- a. As 1703/AR Antennas.
 - (1) Wrap threaded end of antenna with barrier material (C-3) secure with tape (C-25).
 - (2) Pack in fiberboard box (C-27).
- b. CU-942CARC Couplers
 - (1) Wrap coupler with barrier material (C-3) secure with tape (C-25).
 - (2) Pack in fiberboard box (C-27).
- c. Antenna Bracket Assemblies (FM).
 - (1) Wrap assemblies with barrier material (C-3) secure with tape (C-25).
 - (2) Pack in fiberboard box (C-27).
- d. Inspection Plates and Cable Duct, Plate and Entrance Assemblies.
 - (1) Wrap assemblies with barrier material (C-3) secure with tape (C-25).
 - (2) Pack in fiberboard box (C-27).
- e. Antenna Standoffs.
 - (1) Wrap standoffs with barrier material (C-3) secure with tape (C-25).
 - (2) Pack in fiberboard box (C-27).
- f. Antenna Mount Assembly SC-D-972757-UHF.
 - (1) Wrap assembly with barrier material (C-3) secure with tape (C-25).
 - (2) Pack in fiberboard (C-27).
- g. AT-450 ARC Antenna -UHF.
 - (1) Wrap AT-450 antenna with barrier material (C-3) secure with tape (C-25).
 - (2) Pack in fiberboard box (C-27).

- h. Mounting Bracket - PLRS A3053349.
 - (1) Wrap mounting bracket with barrier material (C-3) secure with tape (C-25).
 - (2) Pack in fiberboard box (C-27).
- i. PLRS Antenna AS-3447/ASQ-177.
 - (1) Wrap antenna bracket with barrier material (C-3) secure with tape (C-25).
 - (2) Pack in fiberboard box (C-27).
- j. Access Cover PLRS A3053350.
 - (1) Wrap access cover with barrier material (C-3) secure with tape (C-25).
 - (2) Pack in fiberboard box (C-27).
- k. Mounting Frame Assemblies, SC-D-972731 and SC-D-972733.
 - (1) Wrap frame assemblies with barrier material (C-3) secure with tape (C-25).
 - (2) Pack in fiberboard box (C-27).
- l. Standoff Assemblies and Back Up Plates.
 - (1) Wrap assemblies and plates with barrier material (C-3) secure with tape (C-25).
 - (2) Pack in fiberboard box (C-27).
- m. Power and Coaxial Cable Assemblies.
 - (1) Loop cable assemblies wrap with barrier material (C-3) secure with tape (C-25).
 - (2) Pack in fiberboard box (C-27).
- n. Installation Hardware.
 - (1) Group screws, nuts, bolts, washers, circuit breakers, placard and technical manuals.
 - (2) Pack in bags (C-1) and mark to identify contents of bags.
 - (3) Pack in fiberboard box (C-27).
 - (4) Seal fiberboard box.
 - (5) Secure AN/ASC-15A(V) 3 and 4 Installation Kit Box (C-27).

SECTION III. MARKING**7-22. GENERAL.**

- a. Apply all markings in accordance with MIL-STD-129.
- b. Include helicopter serial number in container markings.
- c. Tag or mark each disassembled part or assembly with correct part or assembly number and serial number of aircraft from which removed.
- d. Indicate center of balance of removed major components with tape, magic pencil, or chalk.

7-23 . ROTOR BLADE CRATES AND STABILIZER BAR BOXES.

- a. Mark each side and end of crate or box in 2-inch stencilled letters: USE NO GRABHOOKS.
- b. Indicate center of balance of loaded crate with a painted black strip 1-inch wide on each side of crate. Extend line 3 inches from lower edge of sheathing. In 1-inch letters adjacent to strip, stencil: "CENTER OF BALANCE".
- c. Indicate sling points by conspicuous arrows and in 1-inch letters: "SLING HERE".

7-24. SPECIAL MARKING.

- a. In addition to any other markings required by shipping instructions, secure in a conspicuous location to outside of aircraft a waterproofed tag stating: HELICOPTER RESERVED ONLY FOR INTERVAL REQUIRED TO REACH DESTINATION. IF NOT SHIPPED WITHIN 15 DAYS OR IMMEDIATELY PREPARED FOR OPERATION UPON RECEIPT, PLACE IN STORAGE STATUS IN ACCORDANCE WITH MAINTENANCE MANUAL.
- b. In addition to tag, include same information with shipping documents.

SECTION IV, DANGEROUS AND HAZARDOUS MATERIALS**7-25. DANGEROUS AND HAZARDOUS MATERIALS.**

- a. Apply special handling instructions, markings and warnings as required by TM 38-250 (AFR 71-4), Packaging and Handling of Dangerous Materials for Transportation by Military Aircraft.
- b. Label all shipments containing dangerous or hazardous materials or any other material requiring special handling with DD Form 1387-2 (Special Handling Data/Certification). Secure form to fuselage or container in a clearly visible location.

APPENDIX A

REFERENCES

STANDARDS, MILITARY MIL-STD-129	Marking for Shipment and Storage
MANUALS, TECHNICAL TM 5-632	Military Entomology Operational Handbook
TM 32-5865-007-10	Special Countermeasure Systems, AN/ALQ-151-V1
TM 32-5865-007-20&P	Special Purpose Countermeasure Systems, AN/ALQ-151-V1
TM 38-250/AFR 71-4	Preparation of Hazardous Materials for Military Air Shipment
TM 55-1500-204-25/1	General Aircraft Maintenance Manual
TM 55-1500-345-23	Painting and Marking of Army Aircraft
TM 55-1520-220-10	Operator's Manual, UH-1C/M
TM 55-1520-220-23	Aviation Unit and Intermediate Maintenance Instructions UH-1C/M
TM 55-1520-210-10	Operator's Manual, UH-1H/V
TM 55-1520-210-23	Aviation Unit and Intermediate Maintenance Instructions UH-1H/V & EH-1
TM 55-2835-203-24	APU Organizational, DS and GS Maintenance Manual
TM 55-2840-229-23	Engine Organizational, DS and GS Maintenance Manual
BULLETINS, TECHNICAL TB 55-9150-200-24	Engine and Transmission Oils, Fuels and Additives for Army Aircraft
REGULATIONS, ARMY AR 40-12	Medical and Agricultural Foreign and Domestic Quarantine Inspections
AR 380-5	Department of the Army Supplement to DOD 5200.1-R

APPENDIX B

PRESERVATION CHECKSHEET

The activity preparing aircraft for shipment may use this appendix as a guide in writing checksheets to fit particular shop practices, working conditions, and manpower. Checksheets are only a record of what has been accomplished. Reference to the manual is required to determine how procedures are accomplished.

ITEM NO.	ITEM DESCRIPTION	MECH	INSP
-------------	---------------------	------	------

PRESERVATION STATUS

- | | | | |
|----|----------------------------------|--|--|
| 1. | Aircraft serial number: | | |
| 2. | Date aircraft received: | | |
| 3. | Date of preliminary inspection: | | |
| 4. | Preservation applied at receipt: | | |
| 5. | Date preservation completed: | | |
| 6. | Date aircraft shipped: | | |
-

PREPARATION FOR SHIPMENT

- | | | | |
|----|--|--|--|
| 1. | Ground aircraft. | | |
| 2. | Clean aircraft interior. | | |
| 3. | Open all drains. | | |
| 4. | Clean plexiglass. | | |
| 5. | Clean exterior surfaces. | | |
| 6. | Wash rotor blades; rinse thoroughly. | | |
| 7. | Inspect aircraft for corrosion. Treat as necessary in accordance with local procedure. | | |
| 8. | Lubricate aircraft as necessary in accordance with lubrication chart. | | |

PREPARATION FOR SHIPMENT

9. Service engine, main transmission, and gear boxes to normal operating level with operating oil.
 10. Service hydraulic system to normal operating level with operating fluid. Repair leaks, as necessary.
-

ENGINE

1. Clean engine particle separator and FOD screen
 2. Add corrosion preventive to engine oil and gear boxes.
 3. Perform ground runup, if necessary.
 4. Disconnect cable to ignition unit.
 5. Remove, clean, and reinstall fuel inlet and pump discharge strainers and servo supply filter.
 6. Motor engine and preserve compressor blades.
 7. Preserve fuel control.
 8. Connect fuel inlet hose and starting fuel hose.
 9. Connect battery.
 10. Seal bleed band.
 11. Clean oil filter.
 12. Clean fuel filter.
 13. Record preservation on aircraft forms.
 14. Rag controls explaining engine preservation.
-

FUEL TANKS: FUELED

1. Drain or add fuel as necessary to fill tanks to 3/4 capacity.
2. Tag fuel cap.

FUEL TANKS: DRAINED

1. Drain fuel tanks.
 2. Flush tanks with diesel fuel.
 3. Purge tanks with diesel fuel.
 4. Tag fuel caps.
-

MAIN ROTOR BLADES

1. Color code main rotor blades; identify with aircraft serial number.
 2. Remove main rotor blades.
 3. Preserve and wrap blades.
 4. Secure blades in container.
-

STABILIZER BAR: REMOVED

1. Color code stabilizer bar, main rotor hub, damper assembly, swashplate, and scissors assembly.
 2. Remove stabilizer bar and control rods.
 3. Cushion, wrap, and secure stabilizer bar in container.
-

MAIN ROTOR HEAD AND MAST ASSEMBLY

1. Preserve blade retention and drag link bolts, shims, washers, and nuts. Reinstall in main rotor grip.
2. Cushion and secure damper assembly.
3. Wrap boot.
4. Install lock blocks and rip positioning links.
5. Wrap main rotor hub, mast assembly, and stabilizer bar (if installed). Secure joints and lash snugly.

TAIL ROTOR BLADES: INSTALLED

1. Preserve all bare metal surfaces of tail rotor assembly.
 2. Wrap assembly.
 3. Install covers, if available.
 4. Cushion and secure rotor blade to tail pylon.
-

TAIL ROTOR BLADES: REMOVED

1. Color code blades.
 2. Remove blades.
 3. Replace nuts, bolts, and washers in tail rotor hub.
 4. Preserve tail rotor assembly and tail rotor blades.
 5. Wrap and cushion rotor blades and assembly.
 6. Secure blades in helicopter.
-

BATTERY

1. Pull quick disconnect plug.
 2. Clean and reinstall battery, quick disconnect plug, carrier, sump jar, felt pad and vent hoses.
 3. Secure quick disconnect plug to airframe.
-

FUSELAGE

1. Remove external rear view mirror. Stow in baggage compartment.
2. Remove antenna wands. Wrap and stow inside helicopter.
3. Remove whip antenna. Wrap and stow inside helicopter.
4. Attach pilot and co-pilot seat belts and shoulder harness; tighten; roll and tape ends.

FUSELAGE

5. Attach passenger seat belts; tighten; roll and tape ends.
6. If not firmly installed, fold seats against bulkhead and secure.
7. Secure cover on pitot tube or wrap and tape.
8. Secure overhead instrument lights and headset cords to overhead panel fixture.
9. Cage instruments.
10. De-energize circuit breaker panels.
11. Lock collective pitch control.
12. Center and lock cyclic control stick.
13. Install shackle on each tiedown eye.
14. Remove windshield wiper arms and blades, Wrap and secure in helicopter.
15. Secure cargo suspension hook.
16. Secure headsets.
17. Secure fire extinguishers.
18. Pack loose gear in cargo compartment.
19. Stow historic records and maintenance manuals within helicopter.
20. Remove lower breakaway tip. Wrap and stow inside helicopter.
21. Remove upper cutter assembly and struts. Wrap and stow inside helicopter.

LANDING GEAR: REMOVED

1. Paint or preserve bare metal areas on skid and cross tubes.
2. Hoist aircraft and remove landing gear.
3. Separate skid tubes from cross tubes.
4. Cushion, wrap, and secure tubes in container.

APPENDIX C

DEPRESERVATION CHECKSHEET

The activity preparing aircraft for shipment is also responsible for writing depreservation instructions based on actual preservation applied. Preservation checksheets must be carefully read and understood prior to depreservation.

ITEM NO.	ITEM DESCRIPTION	MECH	INSP
AIRCRAFT: GENERAL			
1.	Ground aircraft.		
2.	Assemble and install skid landing gear.		
3.	Install ground handling wheels to move aircraft as necessary.		
ENGINE TRANSMISSION AND GEAR BOXES			
1.	Remove all tape and barrier material.		
2.	Check engine transmission and gear boxes for proper oil level.		
FUEL SYSTEM			
1.	Fill fuel tanks with operating fuel.		
2.	Disconnect fuel line at fuel nozzle.		
3.	Motor engine with auxiliary power unit until clear fuel discharges from open fuel line.		
4.	Connect fuel line at fuel nozzle.		
BATTERY			
1.	Remove all tape and barrier material.		
2.	Connect quick disconnect plug to battery.		
3.	Connect ground cable to battery.		

MAIN ROTOR HEAD AND MAST ASSEMBLY

1. Remove covering material from main rotor head and mast assembly,
 2. Remove lock blocks.
 3. Install stabilizer bar (if removed).
 4. Install main rotor blades.
-

TAIL ROTOR ASSEMBLY

1. Remove tape and barrier material from tail rotor assembly.
 2. Remove preservative with P-D-680 solvent.
 3. Install tail rotor blades (if removed).
-

FUSELAGE

1. Remove all tape and barrier material.
2. Clean all plexiglass surfaces.
3. Replace external rear view mirror.
4. Replace antennas.
5. Prepare seats, seat belts, and shoulder harnesses.
6. Remove cover from pitot tube.
7. Close drains.
8. Replace head sets, instruments lights, windshield wipers, and fire extinguishers.
9. Uncage instruments.
10. Energize circuit breaker panels.
11. Unlock collective pitch and cyclic controls.
12. Replace maintenance manuals and historical records on pilot's seat.
13. Replace breakaway tip.
14. Replace upper cutter assembly and struts.

APPENDIX D
CONSUMABLE MATERIALS

NOTE

Method of shipment dictates materials and amounts needed. Any given packaging material may have different length, widths, thicknesses, or other variations, reflected by several NSNs. Thus the following NSNs are for guidance only.

NO.	NSN	QTY RQR	ITEM DESCRIPTION
C-1	8105-00-274-2390	4 ea	Bag, waterproof, greaseproof, flexible, MIL-B-117
C-2	8135-00-753-4661	25 yds	Barrier material, greaseproof, waterproof, flexible MIL-B-121, type I, grade A, class 2, 36 in X 100 yds
C-3	8135-00-282-0565	100 yds	Barrier material, watervaporproof, flexible, MIL-B-131, class 1, 36 in x 200 yds
C-4	6810-00-264-6535	1 lb	Boric acid flakes (Chemical analytical), O-C-265, 1 lb bottle
C-5	6850-00-142-9582	2 cans	Brayco 599, rust preventive, concentrate, 8 oz can
C-6	7920-00-051-4384	4 ea	Brush, MIL-B-23958, type III, size 1, 5 3/8 in diameter at block
C-7	6850-00-935-0095	1 can	Cleaning compound, aircraft surface, alkaline, water base, MIL-C-25769, 5 gal can
C-8	6850-00-033-8851	2 qts	Cleaning compound, solvent, trichlorotrifluoroethane, MIL-C-81302, type II, 10 gal drum
C-9	7930-00-634-5340	1 pt	Cleaning and polishing compound, transparent plastic aircraft materials, P-P-560, type I, 1 pt bottle

NO.	NSN	QTY RQR	ITEM DESCRIPTION
C-10	8030-00-231-2353	5 gal	Corrosion preventive compound, petrolatum, hot application, MIL-C-11796, class 3, 5 gal can
C-11	8030-00-244-1297	2 gal	Corrosion preventive compound, solvent cutback, cold application, MIL-C-16173, grade 2, 1 gal can
C-12	8135-00-180-5922	30 yds	Cushioning material, polyethylene foam sheeting, PPP-C-1752, 1/2 in x 48 in x 60 ft
C-13	8135-00-300-4905	30 yds	Cushioning material, unicellular, polypropylene foam, PPP-C-1797, 1/4 in x 30 in x 225 ft
C-14	9140-00-286-5294	230 gal	Diesel fuel, MIL-F-16884, #2 grade, bulk
C-15	6850-00-285-8011	3 gal	Dry cleaning solvent, P-D-680, type 2, 55 gal drum
C-16	As Rqr	4 ea	Fiberboard box, PPP-B-636
C-17	6840-00-142-9438	6 strips	Insecticide, dichlorvovs strips, DOD-I-51323, 2 in, 144 per case
C-18	9150-00-231-6676	3 gal	Lubricating oil, aircraft turbine engine, petroleum base, MIL-L-6081, grade 1010, 55 gal drum
C-19	6810-00-238-8119	1 pt	Naphtha, aliphatic, TT-N-95, type II, 1 gal can
C-20	6840-00-089-4664	6 blocks	Rodenticide, bait block, diaphacin paraffin, 40 8-oz blocks per carton
C-21	4020-00-928-3438	100 ft	Rope, nylon, MIL-R-17343 (1/4 in OD), 3/4 in circumference, 600 ft coil
C-22	9320-00-232-2474	1 sheet	Rubber, latex foam sponge, MIL-R-5001, type II, 60 x 36 x 7/8 in
C-23	9320-00-143-8600	4 ea	Rubber, sheeted, synthetic, molded, MIL-R-6855, class 2 3/8 x 36 x 36 in

NO.	NSN	QTY RQR	ITEM DESCRIPTION
C-24	8520-00-531-6484	1 bar	Soap, white, P-S-620, type 1,6 oz bar
C-25	7510-00-266-5016	1 roll	Tape, pressure sensitive, PPP-T-60, type IV, class 1,2 in x 60 yds.
C-26	8030-00-838-7789	1 can	WD 40 rust inhibitor and preventive, MIL-C-23411, type I, 60 oz aerosol can
C-27	As Req'd	1 each	Fiberboard box, PPP-B-636 11 1/4 in x 25 1/4 in x 57 in
C-28	As Req'd	1 each	AN/ASC-15A (V) 3 and 4 Kit Box, lumber, MIL-C-104 Group II 15 1/2 in x 27 in x 60 1/2 in

APPENDIX E

SPECIAL TOOLS AND EQUIPMENT

NSN	PIN	(FSCM)	ITEM DESCRIPTION
7130-00-427-7939	SW1961-2	(56048)	Blade Tiedown Assembly
6665-00-664-4650	89220	(49012)	Combustible Gas Indicator
1730-00-908-4853	204-040-929-29	(D0216)	Cover and Lift Plate Assembly (Transmission Cover Plate)
1740-00-464-5745	68SAVAE-D-300-1 69SAVAE-D-0585-4	(81996) (12757)	Dolly Wheels Fuselage Shipping Supports
1730-00-980-9552	204-050-200-5	(D0216)	Ground Handling Wheels (UH-1 B)
1730-00-203-4697	42G7523	(81349)	Jack Axle, 10-Ton
1730-00-831-0290	67 AMXAC-D-0360	(12757)	Kit, Tail Boom Support, UH-1A/B/C (Piggy-Back)
1730-00-831-0332	67SAVAE-D-0585	(12757)	Kit, Tail Boom Support, UH-1 H (Piggy-Back)
1730-00-168-1466	173QTPO02	(81996)	Loading and Positioning Device
4920-00-718-6673	T101348 AN116-10		Piggy-back Grip Positioning Link Shackle
4030-00-951-4431	NAS1042-5	(80205)	Shackle
1730-00-138-5337	1730QNP000-2	(54032)	Shipping Cover, With Blades
1730-00-217-6622	1730QNP000-3	(54032)	Shipping Cover, Without Blades
1740-00-245-8503	2051120 68SAVAE-D-0231 67AMXAC-D-03605 67SAVAE-D-0585-4	(81996) (12757) (12757)	Shipping Skid, UH-1 H (Side-Saddle) Tailboom Shipping Racks Transmission Adapter Transmission Adapter
1730-00-140-4364	1560 UH-1 715-1	(81996)	Wheel Modification Kit

APPENDIX F

QUARANTINE INSPECTION

F-1. SCOPE.

This appendix describes procedures for preparing aircraft (including removed components packed separately) for quarantine inspection, and for reprocessing them upon arrival at destination. It is derived from AR 40-12 and TM 5-632, and is presented for your information.

F-2. PREPARATION OF MATERIAL FOR QUARANTINE INSPECTION.

a. Free aircraft and containers of soil before loading on ships or cargo aircraft.

b. Clear containers of spilled grain, food, and soil before loading with cargo or returning empty to CONUS.

c. Inspect containers and packing materials for termites, wood borers and other insect infestations before using. Never use infected wood or packing material.

d. Inspect all containers and packing material immediately prior to packing to ensure the absence of rodents, snakes, and other animals and insects.

e. Use only authorized packing material. Never use native grasses or fibers. Store all packing materials to prevent infestation by insects or rodents.

f. Attach dichlorvovous strips (C-17) to the interior of each closed container larger than 10 cubic feet at a rate of 5 linear inches of strips per CONEX.

(1) Use three 2-inch strips per CONEX and equal or lesser amounts for smaller containers.

(2) Use slightly larger amounts for crates or boxes with small vent holes and for aircraft that cannot be completely sealed.

(3) Consider all accessible areas within an aircraft, including the tailboom, as a closed container.

(4) Since dichlorvovous strips operate by vapor release, do not use in open containers.

g. Use two 5-inch strips or six 2-inch strips (C-17) per aircraft which is sealed while being processed for return to CONUS. Suspend strips in different locations rather than in a single site.

WARNING

Wear rubber gloves, protective clothing and respirators as recommended by post surgeon or safety officer when placing or removing rodenticide bait blocks .

b. Place one rodenticide bait block (C-20) near the door of the aircraft. Lead the red tape attached to the block outside the aircraft so as to be clearly visible when the door is sealed.

i. Supplies and equipment should be available in the command.

j. If these instructions vary from command regulations regarding shipment of retrograde cargo, consult the command entomologist for technical assistance and advice.

F-3. REPROCESSING OF TREATED MATERIAL.

a. Collect and dispose of insecticides and rodenticides during aircraft depreservation.

(1) All containers and aircraft with red tape extending from them contain one or more blocks of rodenticide. Remove bait blocks before individual items are unpacked or equipment processed.

(2) Store dichlorovous strips and bait blocks in separate closed containers for collection by the post engineer for proper disposal.

b. Notify post engineer or surgeon immediately if living or dead insects, rodents, or other animals are found during depreservation.

APPENDIX G**HEAT SHRINK FILM HELICOPTER PROTECTIVE COVERING**

for

UH-1/EH-1

G-1. Purpose. These instructions are prepared to assist personnel in the installation of protective covering on the UH-1 helicopter during transport via vessel and tractor-trailer truck.

G-2. General:

- a. Polyethylene heat shrink film, materials, and equipment as listed in Table G-1 have been approved for use in the protection of Army helicopters from corrosion, salt water spray, dirt, dust, and foreign objects.
- b. Protective covering is required for all helicopters shipped on the top deck of a vessel and in areas that may be subjected to salt laden spray. Helicopters shipped under hatch covers will be protected with plastic sheets as a minimum. Protective covering of helicopters shipped below deck is the option of the Commander. The Commanders' decision on the amount of protection required will be based on the resources available and the below deck environment of the vessel used for shipment. For helicopters shipped below deck, it is approved to partially cover the helicopter and/or partially shrink the film cover.
- c. Protective covering will be applied to those helicopters being shipped by tractor-trailer truck on highways. The level of protective covering required for short distance shipments by military truck will be determined by the shipper.
- d. The helicopter will be disassembled, preserved, and prepared for shipment in accordance with Chapter 3 or Chapter 4 of this manual, as applicable.
- e. Installation of protective covering is the responsibility of the shipper.
- f. When applying the protective covering, heat shrink film, sufficient working space around the helicopter will be provided to move the maintenance stands, ladders, supplies and equipment.
- g. In addition to the equipment listed in Table G-1, it is essential that an adequate number of maintenance stands are available for preparation and covering of aircraft. There should be two stands for each aircraft being prepared at a given time. For the uncovering process, a single maintenance stand will be adequate.
- h. Insure that adequate waste receptacles are available for waste film and cushioning materials - for both covering and uncovering process.
- i. Environmental conditions of rain and wind cause considerable difficulty in the application of the helicopter protective covering, and should be avoided if possible. Although the preferred method of covering is outdoors, the covering is approved for installation indoors providing the safety precautions of paragraph G-3 are adhered to.
- j. For planning purposes, one UH-1 will require approximately 160 ft. of 14 ft. wide heat shrink film, two rolls of heat shrink tape, 1/2 roll of cushioning material, four plastic vents, the pounds of propane, and 200 ft of polyester stapping.

TABLE G-1

MATERIALS AND EQUIPMENT LIST

NOMENCLATURE	UNIT	P/N, SPEC, (FSCM)	NSN
Plastic, Heat Shrink Film, White, 7 MIL, 14' x 200'	Roll	8135SDP000-1	8135-01-250-4931
Plastic, Heat Shrink Film White, 7 MIL, 20' x 200'	Roll	8135SDP000-2	8135-01-250-2301
Tape, Heat Shrink 2"	Roll	7510SDP000-1	7510-01-250-2299
Heat Cannon Kit, Propane	Each	3540SDP000-1 (81996)	4940-01-250-2300
Cylinder, Empty, Propane, 25 lb.	Each	RR-C-910/2	8120-00-530-5225
Knife, Safe-t-Cut	Each	Model 100HD	7330-01-255-3444
Gloves, Safety, Leather	Pair	A-A-50022	8415-00-269-0433
Cushioning Material 1/4" X 30" X 255"	Roll	PPP-C-1797	8135-00-300-4905
Vent White Plastic, Stick-on, Air	Each	Airlette Corp	8115-01-255-3445
Strapping polyester 1/2"	Roll	R40 (62780)	8135-00-956-2151
Combustible Gas Indicator	Each		6665-00-941-6554

k. The optimum number of personnel for the covering procedure is three per aircraft. One helicopter will require 3 persons approximately 4 hours to cover. With experience, elapsed time can be reduced to 3 hours. Adverse weather conditions and/or dirty (oily) helicopters will increase the optimum number. It is highly recommended that personnel become thoroughly familiar with the heat shrink process prior to working on a helicopter. This can be accomplished by applying the general procedure to available objects such as boxes or crates for practice.

G-3. SAFETY: The below minimum safety procedures will be followed to insure a safe heat shrink operation.

- a. Comply with all safety procedures outlined in applicable chapter three or four of this manual.
- b. Ground the helicopter in accordance with TM 55-1520-210-23.
- c. Insure that fuel tank levels are properly adjusted for shipping (maximum 3/4 capacity or 150 gallons per tank, whichever is less).
- d. Seal fuel filler ports, vents, drains, and battery vents prior to covering the aircraft.
- e. Provide fire truck and adequate fire fighting equipment on site and ready for use prior to operating the heat cannon.
- f. Insure that the helicopter exterior and the adjacent area is free of fuel and other combustibles prior to operating the heat cannon.
- g. The helicopter will be covered outdoors if environmental conditions permit. The covering procedure maybe accomplished in a hanger if the following additional procedures are adhered to:
 - (1) The area must be well ventilated.
 - (2) No other aircraft will be within 50 feet of the helicopter being covered.
 - (3) No other maintenance operations will be permitted in the hangar while the helicopter is being covered.
- h. Prior to the operation of the heat cannon, the helicopter and adjacent areas will be tested with an M-6 combustible gas indicator set (or equivalent) for combustible vapor. The areas to be tested on the helicopter are the fuel filler, drain, and vent ports, the battery vents, and the engine compartment. If the indicator shows an unsafe condition, do not attempt to apply heat shrink film.
- i. Aircraft will be inspected for fuel leaks prior to covering. No attempt will be made to cover aircraft that are known to have or suspected of having fuel leaks.
- j. Covering on the helicopter will be applied so that large pieces of film are centered on fuel filler ports, vents, and drains so that no joining seams are formed near potential fuel fume sources. Fuel filler ports, vents, and drains should be padded with cushioning materials to further protect from heat.
- k. After the covering and shrinking process is complete, the film will be cut to allow removal of the tape seals applied to fuel vents. Heat shrink tape will be used to re-seal heat shrink film.
- l. Leather safety gloves will be worn while using the heat cannon.
- m. Table G-2, safety checksheet will be completed prior to the use of the heat cannon. The completed checksheet will be attached to DA Form 2408-13.

TABLE G-2

SAFETY CHECKLIST

Item	Item Description	Mech	Insp
1.	Ground Helicopter in accordance with TM 55-1520-210-23		
2.	Fire truck/Fire Fighting Equipment ready for use TM 55-1520-242-S		
3.	Adjust fuel levels TM 55-1520-242-S		
4.	Cover fuel access, vent and drain areas. TM 55-1520-242-S		
5.	Perform test with M-6 combustible gas indicator TM 55-1520-242-S		
6.	Working area well ventilated TM 55-1520-242-S		

AFTER COVERING COMPLETE

7.	Inspect covering TM 55-1520-242-S		
8.	Remove seal from fuel vent areas and tape film openings. TM 55-1520-242-S		
9.	Make Handling Instructions entry on DD Form 1387-2 "Fuel in Tanks". Attach form to helicopter cover. TM 55-1520-242-S		

WARNING

Composite main rotor and tail rotor blades, rubber plexiglass, and plastic surfaces, are heat sensitive. These surfaces must be completely covered with cushioning material to provide insulation to prevent serious damage to the helicopter.

G-4. HELICOPTER PREPARATION: Insure that the helicopter is prepared for shipment in accordance with either Chapter Three or Four of this manual as applicable.

a. Aircraft Cleaning. Wash aircraft in accordance with this manual. This is necessary to remove corrosive substances such as dirt, bugs and exhaust residue. It will make the task of helicopter preparation much easier by providing an oil free surface for the adhesion of tape. A dirty aircraft will take more time to cover.

b. Flyaway Equipment. Install flyaway equipment covers in accordance with either Chapter Three or Four of this manual as applicable.

c. OAT Guage. Remove OAT guage and tape to Cyclic.

d. Protect Windshield and Plexiglass Windows. Install foam cushioning material over glass and plexiglass surfaces to prevent scratching and protect them from heat. Secure padding with heat shrink tape using care not to apply tape to glass or plexiglass areas.

e. Seal Vents. Seal all fuel filler ports, drains, and vents, and battery vents. Seal with heat shrink tape and film. These areas must remain sealed throughout the heat shrink process. All but the fuel vents may remain sealed after covering.

f. Preparation of Sharp Edges, Protrusions, and Heat Sensitive Areas. Pad all protrusions and sharp edges with tape or cushioning material to prevent damage to film during the shrinking process and prevent high stress points on the film after shrinking.

(1) Heat shrink tape may be used to protect the film from sharp edges such as the trailing edge of the Horizontal Stabilizer. For best results apply 2 inch wide tape along the bottom edge so that approximately 1/2 inch adheres to the bottom surface. Fold the tape over so that approximately 1/2 inch adheres to the top surface. Tape alone may be used to protect the film from any protrusions such as hinges, louvers, and wing nuts.

(2) Cushioning Material is used to pad protrusions and provide insulation from the heat of the film application process. Cushioning material may be held in place with shrink tape and/or 1/2 inch strapping.

NOTE

Examples below are not intended to all inclusive.

(a) Examples of techniques using cushioning primarily for protection are:

((1)) Wrapping material around the main rotor control tubes.

((2)) Individually wrapping main rotor blade grips.

((3)) Padding over top of and underneath main rotor head.

((4)) Padding over tail rotor head and blade grips.

((5)) Padding over edges of the exhaust stack.

((6)) Padding around pitot tube.

(b) Examples of techniques using cushioning material for both protection and insulation from heat are:

((1)) Complete padding of main rotor blades.

((2)) Complete padding of tail rotor blades.

((3)) Padding of antennae.

((4)) Padding of fuel filler ports, vents and drains.

G-5. APPLICATION OF FILM:

NOTE

Insure that the provisions of Appendix F, quarantine inspection, and customs clearance is obtained for the aircraft prior to the application of heat shrink protective film.

a. Shrink Film Characteristics. The shrink film is provided in a bulk roll. It is a white, opaque, 7 mil thick, polyethylene that contains an ultraviolet inhibitor. The white color is used to reflect the sun to maintain a lower inside temperature. When heated to approximately 325 degree F, the film becomes soft. When the heat is removed the film will shrink about 25% of its original size. The melting temperature of the film is only slightly higher than the shrinking temperature.

b. Heat Cannon Characteristics. The heat cannon operates on bottled propane. It produces an even flame with a temperature of 750 degree F approximately 12 inches from the cannon. The heat cannon has safety features designed to automatically shut off the flame if it is dropped. The open flame is safe for use on aircraft when the procedures of this appendix are strictly adhered to.

c. After the aircraft has been prepared as in paragraph G-4 above, it is ready for the application of the film. The film cover is created by first visually dividing the helicopter into sections. Film sections are cut from the bulk roll with a safety knife to piece together a complete cover. The pieces are held together with heat shrink tape until they are fused together. There is no hard and fast procedure for this phase of the process. The following is a workable procedure:

NOTE

Because the film is subject to damage from handling on rough surfaces it is recommended that a piece of film approximately 14' x 30' be cut and secured to the ground as a measuring and cutting work surface.

WARNING

Insure that adequate maintenance stands are available and all personnel are thoroughly familiar with no step areas prior to covering the helicopter.

(1) Determine sections such as small protrusions, antennae, tail rotors, stabilizers and main rotor controls, that need to be covered separately. They should be wrapped with sufficient excess material to allow later fusing to each other and larger pieces as required.

(2) The larger sections to be wrapped include the blades and the fuselage.

(a) The fuselage can be sectionalized by using the width of the bulk film and cutting it to a length equivalent to the helicopter circumference for the section being wrapped (plus overlap).

(b) Each of the main rotor blades will require a piece of film approximately 27' X 5'.

(3) Large void areas in the film covering are to be avoided. To prevent voids, slits may be cut in large pieces of covering to allow previously covered small protrusions to stick through. Covering on these protrusions will be then fused to the larger piece.



Prior to operating the heat cannon, insure that all requirements of paragraph G-3 have been complied with.

d. Fusing film Pieces Together.

(1) After the helicopter has been completely covered, all seams and pieces must be fused together before the film is shrunk. Where two pieces come together to form a horizontal seam, the top piece should overlap the bottom to prevent the possibility of water entrapment.

(2) To fuse two pieces together to form a seam, pull the pieces together to form a snug fit around the area being covered. A minimum overlap of 6 inches is required for fusing. Hold pieces in place with heat shrink tape. Heat the area to be fused by first shooting the flame between the top and bottom layers to be fused and then holding the heat cannon 8 to 12 inches from the seam and moving the heat along the seam. As the film becomes soft, pat the seam gently with a safety gloved hand (the film is HOT).



To prevent water leakage at seams, insure that seams are completely bonded.

(3) Repeat this process until all seams are fused.

(4) After film has cooled, test seams for proper bonding by trying to pull seams apart with fingernails. If seams come apart, reseal them.

e. Shrinking Film.

(1) After all the seams have been fused and the helicopter has been completely enclosed in film, the shrinking process should be accomplished. To shrink the film, hold the heat gun 8 to 12 inches from the surface and move the gun evenly along the surface. Apply just enough heat to soften the film. After the heat is removed, the film will shrink to a glove tight fit.

(2) If a hole is inadvertently burned through, it may be easily repaired by fusing a piece of film to the damaged area and/or repairing with heat shrink tape.

f. Inspection. When the shrinking process is completed and allowed to set for approximately 30 minutes, inspect the helicopter covering to determine if any areas require further shrinking. Insure that all seams are completely fused and that no holes are present. Repairs may be made as required by applying the procedure in paragraph G-5e above. Insure good seals around landing gear and other protrusions.



Do not attempt to patch, shrink, or fuse the heat shrink material with the heat cannon after fuel and/or battery vents have been unsealed.

G-6. FUEL AND BATTERY VENTS: After the inspection of the covering has been completed and the covering has been found satisfactory, the fuel and battery vents must be unsealed. Cut a small slit in the area of the vent and remove the seal. Repair the cut with tape. Repeat this process for each vent.



Adequate ventilation of the cover is essential to minimize condensation and permit drainage.

G-7. INSTALLATION OF VENTILATORS: After the inspection of the covering has been completed, the covering must be ventilated. Ventilators are to be placed to allow a flow of air through the covering. Each aircraft will require approximately five ventilators. They should be placed to allow air to flow through the helicopter. At least one vent will be required at each low point on the helicopter to drain condensation. The vents are applied by peeling the backing off the adhesive surface and pressing the vent to the shrink film. The cover is then removed and the center hole is cut in the shrink film. The vent cover is then replaced and secured with tape.

G-8. HOISTING: If the helicopter is being hoisted on a vessel or truck, use the applicable procedures in this manual. If the film is damaged it may be repaired with two inch heat shrink tape and/or a piece of heat shrink film taped to the cover.

G-9. TIEDOWN POINTS: After loading the aircraft, restrain in accordance with either chapter three or four of this manual as appropriate.

G-10. ENROUTE MAINTENANCE: Shrink covers should be checked daily by designated escort personnel and/or vessel crew for damage. Damaged areas may be repaired by patching the shrink film using two inch heat shrink tape.

G-11. REMOVAL OF SHRINK FILM: To remove the shrink film, use the safety knife and cut along the top and side surfaces. The shrink film does not adhere to the helicopter and will fall away.



Use only the safety knife when removing the film. A standard knife blade will damage the helicopter.

a. All film and cushioning material will be removed prior to depreservation.

b. Recycling of the used shrink film can be established through the Defence Reutilization and Marketing Service DLA.

G-14. DEPRESERVATION: Depreserve helicopter in accordance with this manual.

APPENDIX H

SIDE-SADDLE KIT

H-1. GENERAL.

The side-saddle kit (P/N 2051120) is used only on UH-1 H helicopters shipped by C-141 cargo aircraft or UH-1 and EH-1's shipped by C-5.

H-2. INSTALLATION OF SIDE-SADDLE KIT.

a. Prepare helicopter in accordance with Chapter 2. In addition, perform the following:

(1) Remove battery from helicopter nose and install in aft battery compartment. Secure quick disconnect plug to airframe.

(2) Wrap disconnected electrical connections with barrier material (C-2) and secure to airframe with tape (C-25).

(3) Install transmission cover plate (P/N 204-040-929-29) on top of transmission case.

(4) Stow disassembled components in cargo compartment and distribute to achieve a balanced load.

(5) Remove left cargo door handle. Secure to litter stanchion with tape (C-25).

(6) Secure both cargo doors open.

(7) Cover cargo door openings with barrier material (C-3) secured with tape (C-25) to prevent rain entry while awaiting shipment.

(8) Secure a large piece of fiberboard under vent tubes and navigation lights with tape (C-25) to protect rotor blade tips, vent tubes, and navigation lights-during loading.

b. Remove skid landing gear. Set helicopter on cross tubes of side-saddle kit.

c. Remove tailboom. Set on a portable rack in the normal configuration.

CAUTION

Place aluminum washers (P/N 960PD816) between attaching fixture and fuselage and between attaching fixture and tailboom to protect airframe surface from damage by fixture.

d. Install tailboom support (component of side-saddle kit) to fuselage at tailboom junction point so that tailboom can be attached on left side of helicopter.

NOTE

Use machine bolts (NAS 628-201/2-20X11/4), aluminum washers (AN 960-PD816) and self locking nuts (MS21044N8) to attach fixture to fuselage and tailboom.

e. Lay aft end of tailboom in cradle on side-saddle kit. Secure forward end of tailboom to attaching fixture.

f. Secure tailboom in cradle with cover.

g. Complete preservation as follows:

(1) Preserve synchronized push rod and bellcrank with corrosion preventive (C-11), wrap with barrier material (C-2), and secure to airframe with tape (C-25).

(2) Coat tailboom attaching bolts, nuts, and washers with corrosion preventive (C-11). Place in a cloth bag, identify, and secure inside fuselage at tailboom junction point.

(3) Enclose fuselage and tailboom openings at tailboom junction point with barrier material (C-3) and secure with tape (C-25).

H-3. LOADING.



UH-1 helicopters mounted on a side-saddle kit are extremely nose heavy. Exercise extreme care in hoisting to avoid damage to helicopter nose.



When using troops to counterbalance nose heavy UH-1, only two men can stand on top of cabin and on designated step on tailboom fixture. Never apply pressure to any other portion of fixture or an excessive torque will be applied to fuselage at tailboom junction area.

a. Hoist helicopter onto two 463L pallets, locked together and mounted on a K-loader. Place forward end of right skid tube 12 inches from pallet edge and aft end of right skid tube 9 1/2 inches from pallet edge.

- b. Secure two 10,000-pound tiedown chains from aft cross tubes on each side of helicopters to 2nd and 3rd tiedown rings on pallets.
- c. Secure one 10,000 pound tiedown chain from forward cross tube on each side of helicopter to 4th tiedown ring on pallets.
- d. Secure pallets to K-loader to prevent movement during loading.
- e. Push palletized helicopters nose first into cargo aircraft to approximately the following locations.

- (1) 1st UH-1: Station 478 to 742 in Mdl.A or station 326 to 590 in Mdl.B.
- (2) 2d UH-1: Station 746 to 1010 in Mdl.A or station 590 to 860 in Mdl.B.
- (3) 3d UH-1: Station 1014 to 1278 in Mdl.A or station 864 to 1128 in Mdl.B.

CAUTION

Use extreme care when stowing rotor blades, blade tips, vent tubes, and navigation lights to prevent damage. Do not place tip of blades forward of station 478 in Mdl.A or station 326 in Mdl.B or they may be damaged by personnel walking on them.

- f. Stow main rotor blades directly under each fuselage.
- g. Secure removed skid landing gear to ramp area of cargo aircraft with 5,000-pound tiedown straps.

H-4. TIEDOWN

- a. Lock 463L pallets in place.
- b. Secure helicopters to cargo aircraft floor with 5,000 pound tiedown straps as follows:
 - (1) Attach one strap to each mooring adapter.
 - (2) Attach two straps to each tiedown shackle.
- c. Secure blades with two 5,000-pound tiedown straps across the tip and root end of the padded blades, and one strap attached to prevent forward movement of the blade.

APPENDIX J

PIGGY-BACK KIT

J-1. Install piggy-back shipping kit (P/N 67-SAVAE-D-0585) on UH-1 H helicopters as follows:

- a. Install transmission adapter (P/N 67-SAVAE-D-0585-4) on top of transmission case.
- b. Place front support (P/N 67-SAVAE-D-0585-2) on top of fuselage aft of roof windows and attach strap (P/N 67-SAVAE-D-0585-5).
- c. Attach aft support assembly (P/N 67-SAVAE-D-0585-3) to aft bulkhead.
- d. Install brace (P/N 67-SAVAE-D-0585-52) from transmission adapter to front support assembly.
- e. Install brace (P/N 67-SAVAE-D-0585-53) from transmission adapter to aft support assembly.
- f. Install brace (P/N 67-SAVAE-D-0585-54) from aft support assembly to fitting at fuselage station 156.
- g. Place tailboom in front support assembly and attach forward end of tailboom to aft support assembly.
- h. Secure aft end of tailboom to forward support assembly with strap (P/N 67-SAVAE-D-0585-6).

J-2. Install piggy-back shipping kits (P/N 67-AMXAC-D-0360) on UH-1B/C/M helicopters as follows:

- a. Install transmission adapter (P/N 67-AMXAC-D-0360-5) on top of transmission case.
- b. Place front rack assembly (P/N 67-AMXAC-D-0360-2) on top of fuselage aft of roof windows and secure with straps (P/N 67-AMXAC-D-0360-8) to mooring fittings at station 78.
- c. Attach aft frame assembly (P/N 67-AMXAC-D-0360-4) to aft bulkhead.
- d. Install upper brace (P/N 67-AMXAC-D-0360-39) from aft frame assembly to bracket (P/N 67-AMXAC-D-0360-47) installed on fuselage fitting at station 149.
- e. Install lower brace (P/N 67-AMXAC-D-0360-38) from aft frame assembly to bracket (P/N 67-AMXAC-D-0360-47) installed on fuselage at station 249.
- f. Install brace (P/N 67-AMXAC-D-0360-37) from transmission adapter to right side of front rack assembly.
- g. Install brace (P/N 67-AMXAC-D-0360-36) from transmission adapter to left side of front rack assembly.
- h. Install arm assembly (P/N 67-AMXAC-D-0360-6) from transmission adapter to brace (P/N 67-AMXAC-D-0360-46) on aft frame assembly.
- i. Install back rack assembly (P/N 67-AMXAC-D-0360-3) on top of aft frame assembly (P/N 67-AMXAC-D-03604).

j. Place tailboom assembly on front and aft rack assembly and secure with straps (PN 67-AMXAC-D-0360-8).

k. Pass two straps through synchronized elevator housing. Attach both ends of one strap to forward rack assembly. Attach both ends of other strap to aft frame assembly.

I-2.2 Installation (cont).**c. Main Rotor Area, -3 Cover.**

(1) Center the cover on rotor hub using the 24 inch piece of zipper marked LIFT POINT, and drape the right side of cover fore and aft along the helicopter.

(2) Carefully insert left and right stabilizer bars and rotor hubs into the sleeves on cover. Fasten all snaps as work progresses.

d. Tail Area.

(1) Check that cover is draped evenly along left and right sides of the helicopter.

(2) Install upper tail rotor blade and antenna into sleeves provided on the cover.

(3) Pull the tail section back and install tail skid in sleeve provided.

(4) Install the cover over right and left elevators.

e. At the nose section, install pitot tubes in sleeves provided.

f. Insert tiedowns through the sleeves provided, and install tiedowns at four crosstube locations.

I-2.3. Closing and Sealing.

a. General. Closing the cover is accomplished with the aid of the zipper closure tool provided with each cover. The closure tool has a roller on one arm of the tool and a channel shoe on the other arm. The roller and shoe are retained by screws, and may be reversed for use in tight corners. When using the tool, pull evenly and use only enough pressure to close the zipper. Too much closing pressure or pulling the tool unevenly will tend to elongate one side of the zipper more than the other; this will cause wrinkling and mismatching. Opposing straps and arrows are provided as guides for even closure. Exact alignment of the straps or arrows is unnecessary, but too much misalignment will cause difficulty when sealing the opposite end of the zipper; at least two inches of the closed zipper end must be folded back on itself for efficient sealing. Open and close the zippers as necessary to achieve reasonable alignment.

b. Closure.

(1) Ensure that cover is centered properly and draped evenly on both sides of the helicopter.

(2) Begin closure at main rotor hub area. On -2 cover, begin closing the fore and aft rotor blades by starting at the end of rotor blades and working toward hub.

(3) Start closure near the tail section and continue along center butt line to rear crosstube.

NOTE

Convergence of the zippers at center of crosstube area forms the main drain tube.

(4) Close the zippers running up crosstubes and diagonally toward the center of crosstube area, then continue closing noise section.

(5) Close zipper in the fuel service area.

(6) Place repair kit and instructions in the pocket at right nose section.

1-2.3 Closing and Sealing (cont).

c. Sealing. If a dehumidifying unit is to be used, seal all openings as follows:

(1) Seal main drain sleeve by folding at least two inches of the shortest member back on itself, seal opening with adhesive (C-29), and secure the fold to sleeve with two inch tape (C-25). Add additional adhesive as necessary to ensure that all air channels have been sealed.

(2) Seal the remaining drain sleeve by folding and taping (C-25).

(3) Seal tiedown sleeves by rolling excess material around the tiedown strap and secure with two inch tape (C-25).

(4) Fold excess material around the crosstubes and secure with two inch tape (C-25). Seal air channels along both sides of zipper with adhesive (C-29), and wrap the sealed area with additional tape.

NOTE

Connect the dehumidifier using as short an input hose as possible (do not exceed 10 feet).

d. Two dehumidifying sleeves are provided: one at the tail rotor area and one forward of the front crosstube. Insert dehumidifier input hose in the front sleeve and return hose in rear sleeve. Roll the excess sleeve material around hoses and secure with two inch tape (C-25).

1-3. REPAIR.

Repair cover material and zippers using materials and instructions supplied with the cover.

By Order of the Secretary of the Army:

E. C. MEYER
General, United States Army
Chief of Staff

Official:

J. C. PENNINGTON
Major General, United States Army
The Adjutant General

DISTRIBUTION:

To be distributed in accordance with DA Form 12-31, Organizational Maintenance Requirements for UH-1B, UH-1C\M, UH-1D\H and EH-1H aircraft.

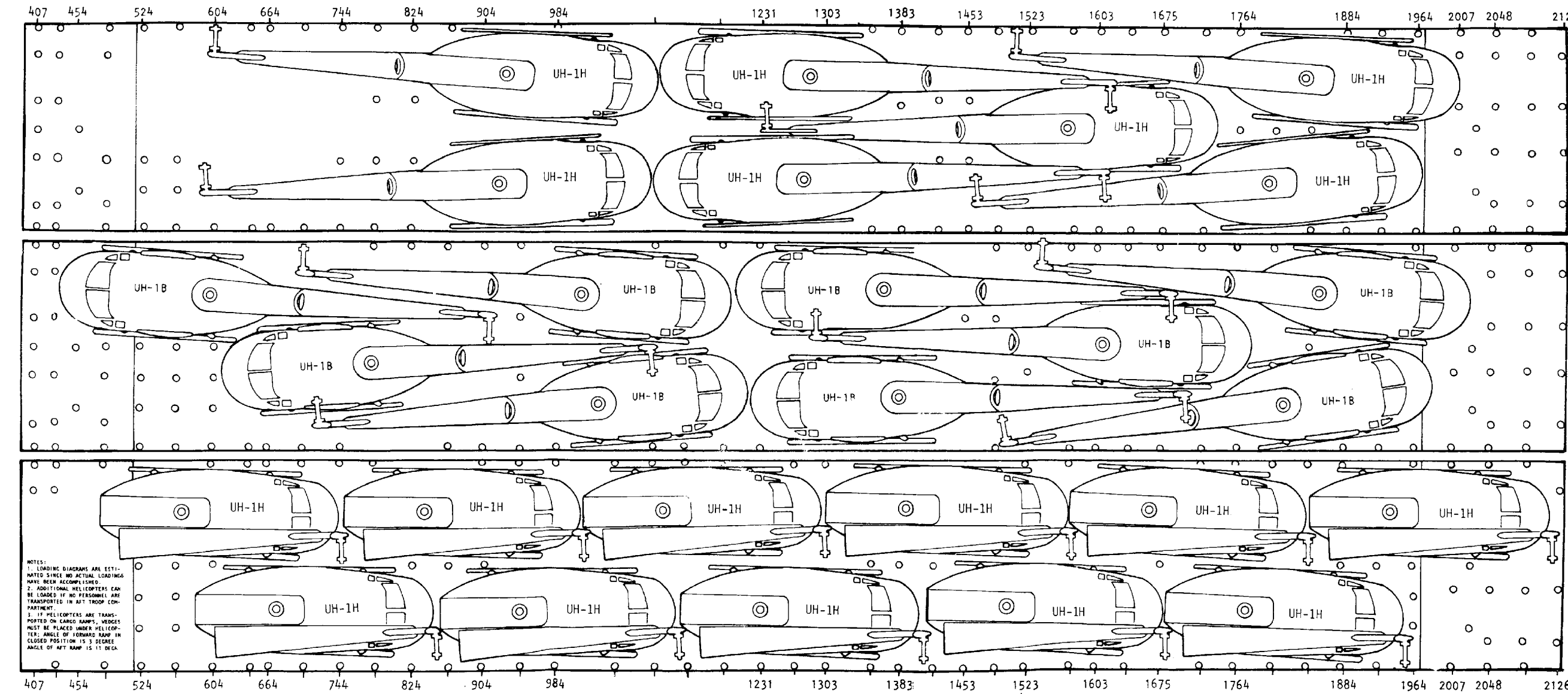

FO-1. C-5 Loading Diagram.

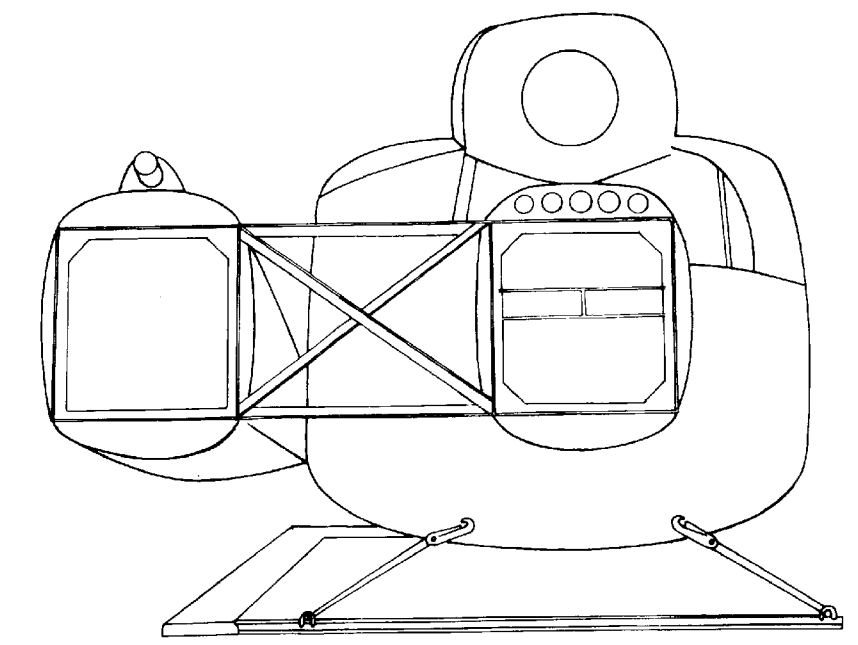
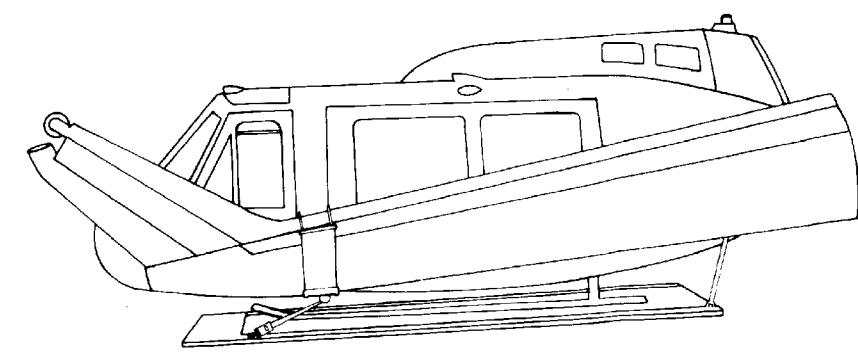

FO-2. Side-Saddle Kit Installed on UH-1D/H/V and EH-1.

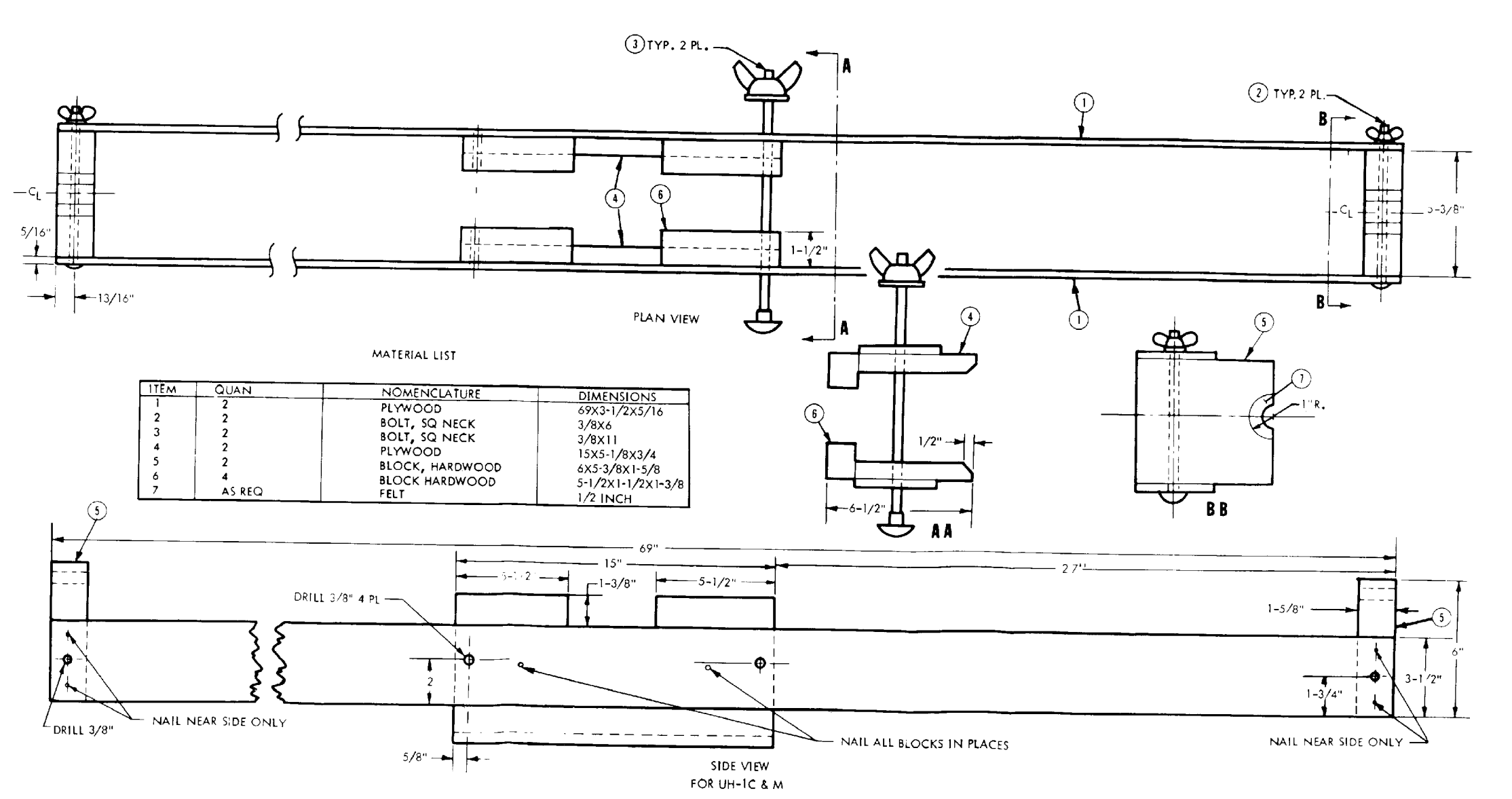
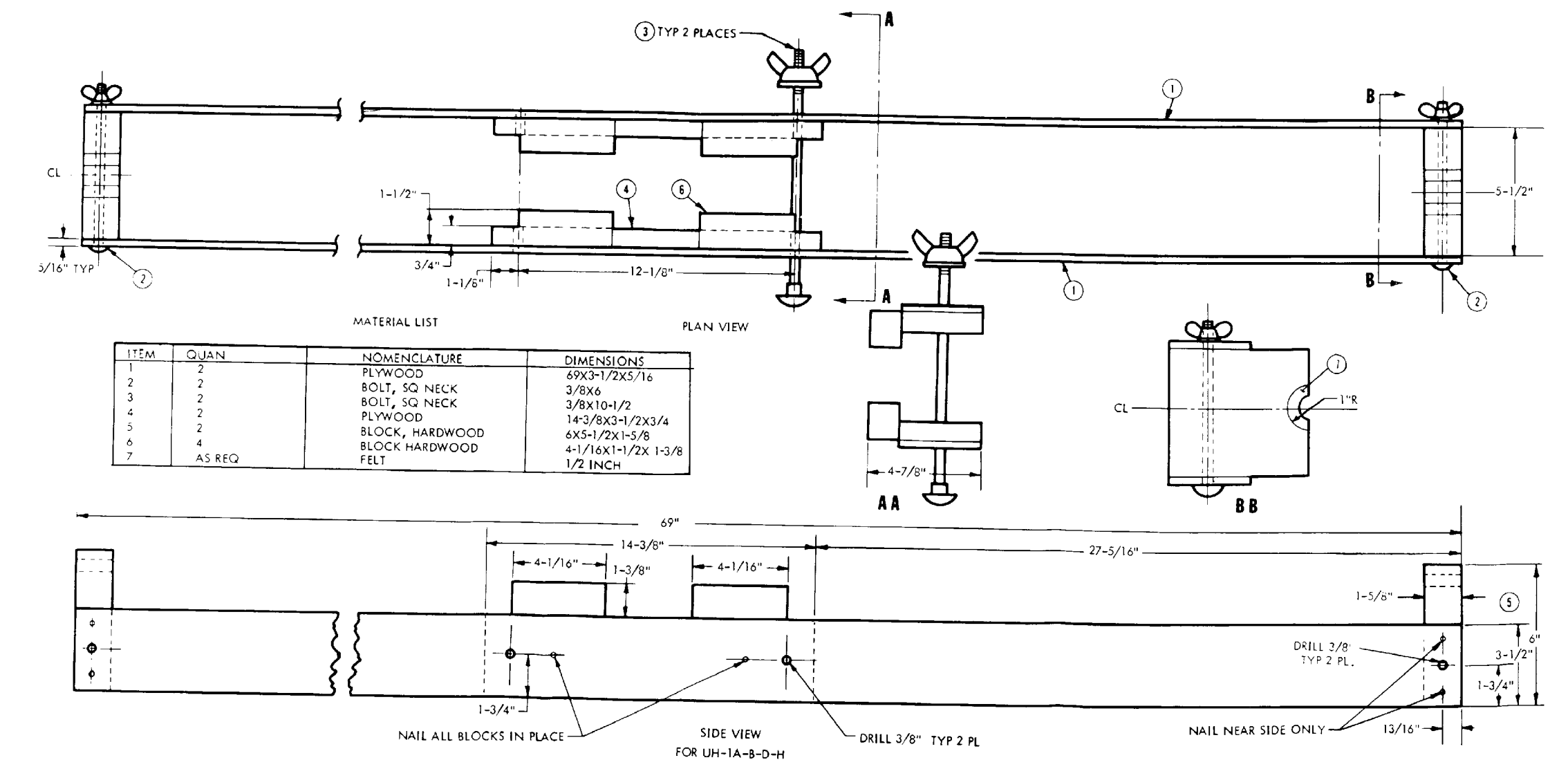

FO-3. Stabilizer Bar Support.

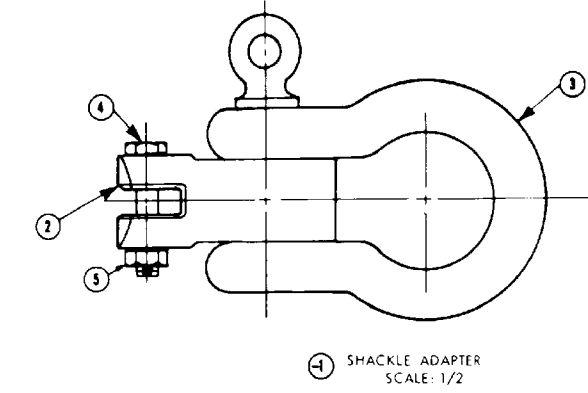
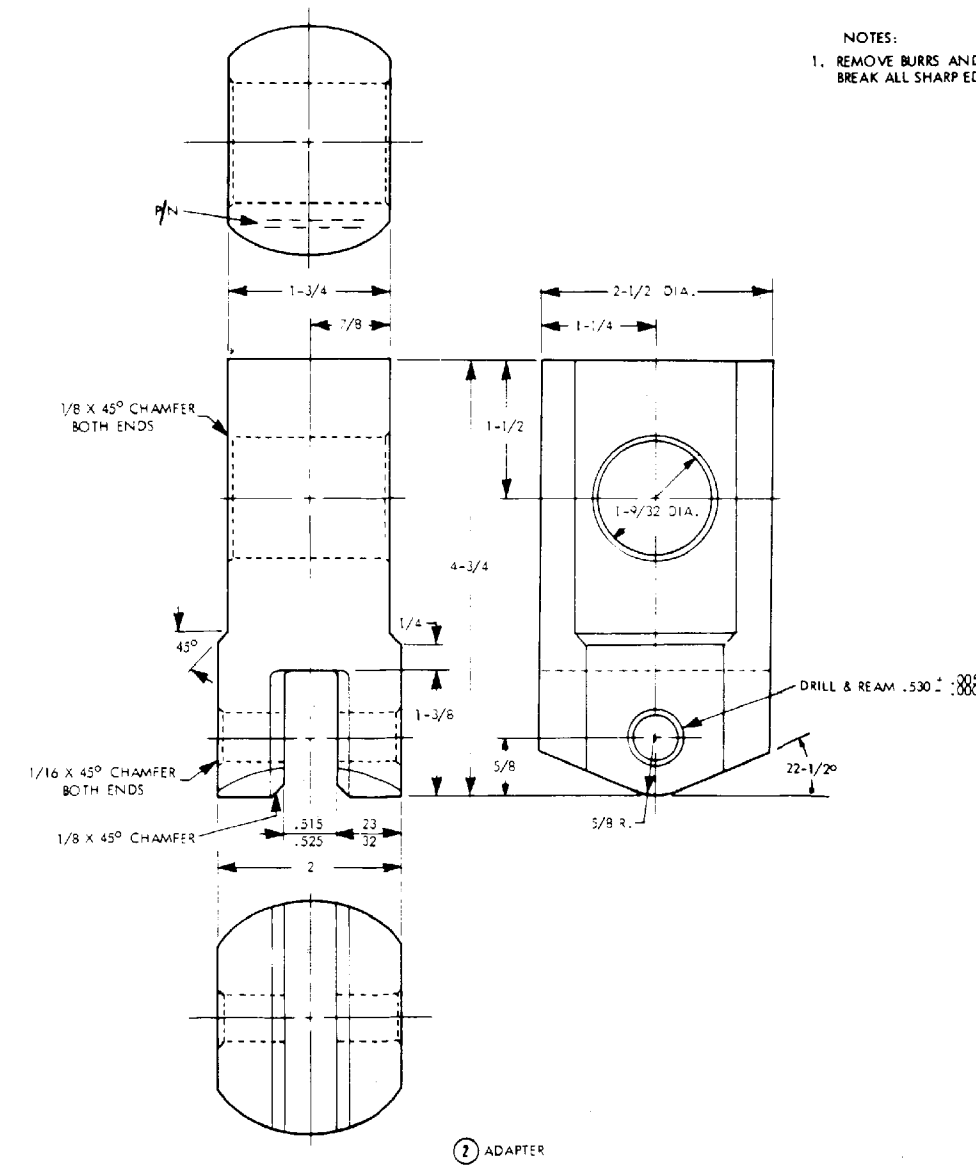

ITEM NO.	QTY.	PART	DESCRIPTION	SPECIFICATION	NOTES
5	1	NUT	1/2 - 20NF	AN315-RR	OR EQUAL
4	1	BOLT CLOSURE	1/2 - 20NF X 2-31/64	NAS464-R	OR EQUAL
3	1	SHACKLE	1-1/4 PIN DIA.	AN 2115-1	OR EQUAL
2	1	ADAPTER	2-1/2 DIA., X 5	4130	FINISH HAUGHTO
-1			ASSEMBLY, SHACKLE ADAPTER		
LIST OF MATERIALS					

FO-5. Shackle Adapter.

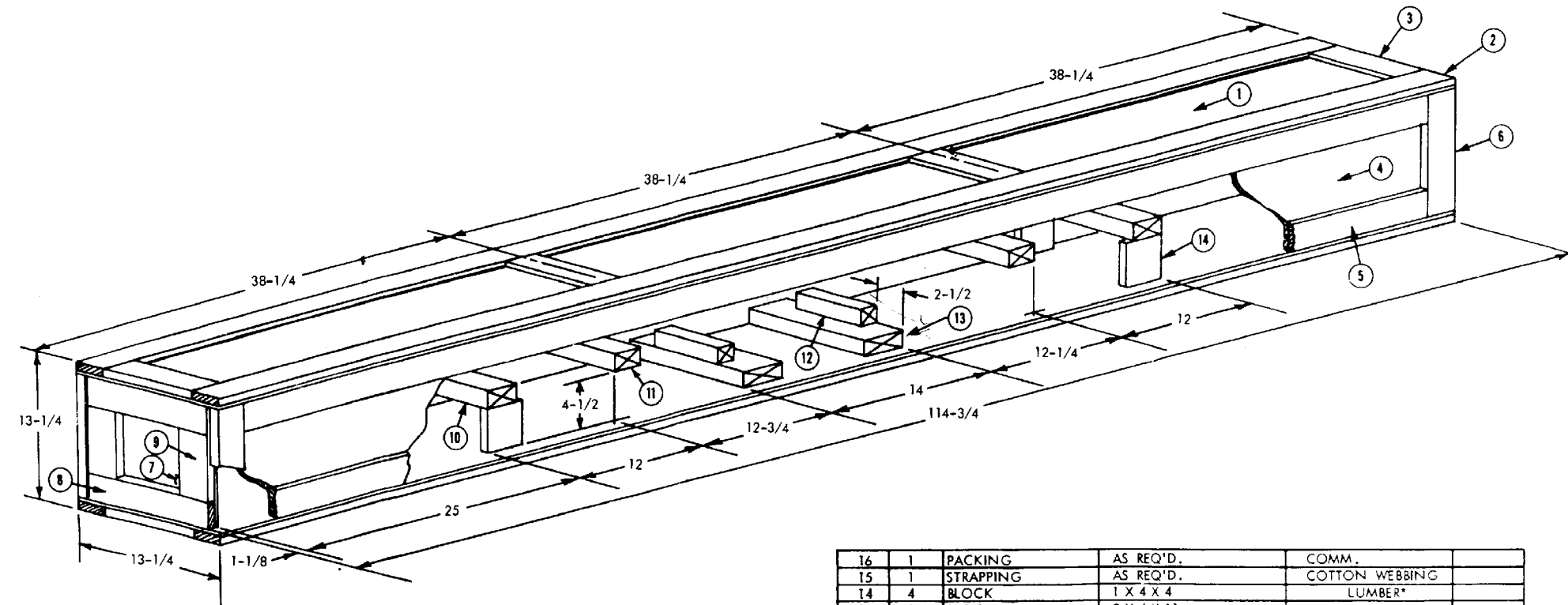

NOTE - MODIFY DIMENSIONS AS NECESSARY FOR UH-1A

** PLYWOOD SHALL BE STANDARD GRADE WITH EXTERIOR GLUE OF U.S. PRODUCT STANDARD PSI-66 (INT-DFPA). PLYWOOD WILL HAVE THE GRADE STAMP OF APPROVED TESTING AGENCY AND WILL BE SURFACE TREATED IN ACCORDANCE WITH TT-W-572.

16	1	PACKING	AS REQ'D.	COMM.	
15	1	STRAPPING	AS REQ'D.	COTTON WEBBING	
14	4	BLOCK	1 X 4 X 4	LUMBER*	
13	2	BLOCK	2 X 4 X 11	"	
12	2	BLOCK	2 X 2 X 6	"	
11	2	BLOCK	2 X 3 X 11	"	
10	2	BLOCK	2 X 4 X 11	"	
9	4	END FRAME	3/4 X 2-1/2 X 6	"	
8	4	END FRAME	3/4 X 2-1/2 X 11	"	
7	2	END	3/8 X 11 X 11	PLYWOOD**	
6	4	SIDE FRAME	3/4 X 2-1/2 X 11	LUMBER*	
5	4	SIDE FRAME	3/4 X 2-1/2 X 109-3/4	"	
4	2	SIDE	3/8 X 11 X 114-3/4	PLYWOOD**	
3	8	TOP or BOTTOM FR.	3/4 X 2-1/2 X 8-1/4	LUMBER*	
2	4	TOP or BOTTOM FR.	3/4 X 2-1/2 X 114-3/4	"	
1	2	TOP or BOTTOM	3/8 X 13-1/4 X 114-3/4	PLYWOOD**	
ITEM NO.	QTY. REQD.	PART	DESCRIPTION	SPECIFICATION	NOTES

*MIL-C-104, GROUP II

FO-6. Stabilizer Bar Box.

RECOMMENDED CHANGES TO EQUIPMENT TECHNICAL PUBLICATIONS



THEN... JOT DOWN THE DOPE ABOUT IT ON THIS FORM. CAREFULLY TEAR IT OUT. FOLD IT AND DROP IT IN THE MAIL!

SOMETHING WRONG WITH THIS PUBLICATION?

FROM: (PRINT YOUR UNIT'S COMPLETE ADDRESS)

PFC JOHN DOE
COA, 3d ENGINEER BN
FT. L. RICHARDWOOD, MO 63108

DATE SENT

PUBLICATION NUMBER

PUBLICATION DATE

PUBLICATION TITLE

BE EXACT... PIN-POINT WHERE IT IS

PAGE NO	PARA-GRAPH	FIGURE NO	TABLE NO
---------	------------	-----------	----------

6

2-1
a

B1

4-3

125

line 20

IN THIS SPACE TELL WHAT IS WRONG AND WHAT SHOULD BE DONE ABOUT IT:

In line 6 of paragraph 2-1a the manual states the engine has 6 cylinders. The engine on my set only has 4 cylinders. Change the manual to show 4 cylinders.

Callout 16 on figure 4-3 is pointing at a bolt. In key to figure 4-3, item 16 is called a shim - Please correct one or the other.

I ordered a gasket, item 19 on figure B-16 by NSN 2 910-00-762-3001. I got a gasket but it doesn't fit. Supply says I got what I ordered, so the NSN is wrong. Please give me a good NSN

PRINTED NAME, GRADE OR TITLE, AND TELEPHONE NUMBER

JOHN DOE, PFC (268) 317-7111

SIGN HERE

JOHN DOE

DA FORM 2028-2
1 JUL 79

PREVIOUS EDITIONS ARE OBSOLETE.

DRSTS-M Overprint 1, 1 Nov 80

P.S. - IF YOUR OUTFIT WANTS TO KNOW ABOUT YOUR RECOMMENDATION MAKE A CARBON COPY OF THIS AND GIVE IT TO YOUR HEADQUARTERS

TEAR ALONG PERFORATED LINE

FILL IN YOUR
UNIT'S ADDRESS

FOLD BACK

DEPARTMENT OF THE ARMY

OFFICIAL BUSINESS

Commander
US Army Aviation Systems Command
ATTN: AMSAV-MC
4300 Goodfellow Boulevard
St. Louis, MO 63120-1798

TEAR ALONG PERFORATED LINE

RECOMMENDED CHANGES TO EQUIPMENT TECHNICAL PUBLICATIONS



THEN... JOT DOWN THE DOPE ABOUT IT ON THIS FORM. CAREFULLY TEAR IT OUT. FOLD IT AND DROP IT IN THE MAIL.

SOMETHING WRONG WITH THIS PUBLICATION?

FROM (PRINT YOUR UNIT'S COMPLETE ADDRESS)

DATE SENT

PUBLICATION NUMBER

PUBLICATION DATE

PUBLICATION TITLE

TM 55-1520-242-S

20 January 1981

Preparation for Shipment of UH-1/EH-1 Helicopters

BE EXACT PIN-POINT WHERE IT IS

IN THIS SPACE TELL WHAT IS WRONG AND WHAT SHOULD BE DONE ABOUT IT:

PAGE NO

PARA-GRAPH

FIGURE NO

TABLE NO

PRINTED NAME GRADE OR TITLE AND TELEPHONE NUMBER

SIGN HERE

FILL IN YOUR
UNIT'S ADDRESS

FOLD BACK

DEPARTMENT OF THE ARMY

OFFICIAL BUSINESS

Commander
US Army Aviation Systems Command
ATTN: AMSAV-MC
4300 Goodfellow Boulevard
St. Louis, MO 63120-1798

TEAR ALONG PERFORATED LINE

RECOMMENDED CHANGES TO EQUIPMENT TECHNICAL PUBLICATIONS



THEN... JOT DOWN THE DOPE ABOUT IT ON THIS FORM. CAREFULLY TEAR IT OUT. FOLD IT AND DROP IT IN THE MAIL.

SOMETHING WRONG WITH THIS PUBLICATION?

FROM (PRINT YOUR UNIT'S COMPLETE ADDRESS)

DATE SENT

PUBLICATION NUMBER TM 55-1520-242-S	PUBLICATION DATE 20 January 1981	PUBLICATION TITLE Preparation for Shipment of UH-1/EH-1 Helicopters
--	-------------------------------------	--

BE EXACT PIN-POINT WHERE IT IS				IN THIS SPACE TELL WHAT IS WRONG AND WHAT SHOULD BE DONE ABOUT IT:
PAGE NO	PARA-GRAPH	FIGURE NO	TABLE NO	

PRINTED NAME GRADE OR TITLE AND TELEPHONE NUMBER	SIGN HERE
--	-----------

FILL IN YOUR
UNIT'S ADDRESS

FOLD BACK

DEPARTMENT OF THE ARMY

OFFICIAL BUSINESS

Commander
US Army Aviation Systems Command
ATTN: AMSAV-MC
4300 Goodfellow Boulevard
St. Louis, MO 63120-1798

TEAR ALONG PERFORATED LINE

FILL IN YOUR
UNIT'S ADDRESS

FOLD BACK

DEPARTMENT OF THE ARMY

OFFICIAL BUSINESS

Commander
US Army Aviation Systems Command
ATTN: AMSAV-MC
4300 Goodfellow Boulevard
St. Louis, MO 63120-1798

TEAR ALONG PERFORATED LINE

