

# ADDENDUM TO UH-1-11-ASAM-02 MAIN ROTOR HUB INBOARD STRAP FITTING

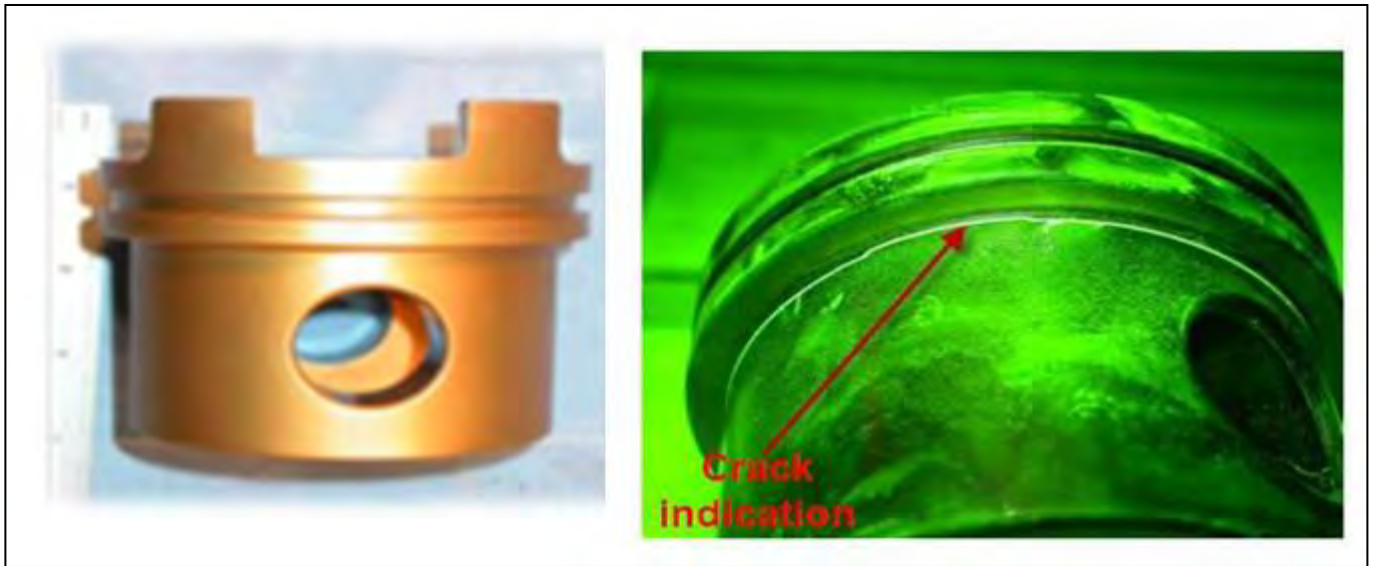
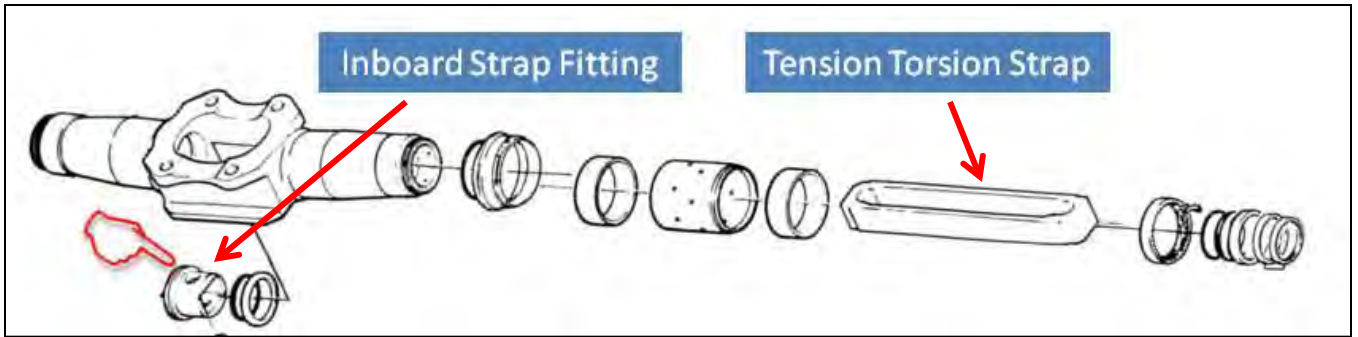

# ADDENDUM TO UH-1-11-ASAM-02

## MAIN ROTOR HUB INBOARD STRAP FITTING

### UH-1 Main Rotor (MR) Inboard Strap Fitting

- 1.0 Description (Figure 1). The MR Inboard Strap Fitting is a machined cylindrical part located in the yoke assembly. It positions the pin which attaches the retention strap.
- 2.0 Defects. Defects are suspected in the radius area shown below in Figure 1. No cracks are allowed.
- 3.0 Primary Method. Magnetic Particle
- 4.0 NDI Equipment and Materials. (Refer to Appendix B.)
  - a. Magnetic Particle Inspection Coil. Refer to TM 1-1500-256-23 paragraph 1.4.8.1.2 and Figure 1-6.
  - b. Magnetometer
  - c. Black Light
  - d. Fluorescent Magnetic Particles
  - e. Consumable Materials, Refer to Table 1-8
  - f. Aircraft Marking Pencil, Refer to Table 1-8
- 5.0 Preparation of Helicopter. The helicopter shall be prepared for safe ground maintenance and the strap fitting removed in accordance with the applicable technical manuals listed in Table 1-1.
- 6.0 Access. Not applicable.

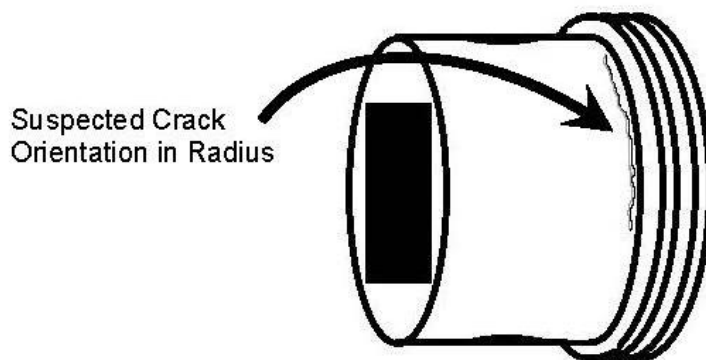

Figure 1

# ADDENDUM TO UH-1-11-ASAM-02

## MAIN ROTOR HUB INBOARD STRAP FITTING

- 7.0 Preparation of Part. The strap fitting shall be thoroughly cleaned. Refer to preparation of part or area for NDI, TM 1-1500-256-23 paragraph 1.4.4.
- 8.0 NDI Equipment Settings. Refer to Magnetic Particle Method, TM 1-1500-256-23 paragraph 1.4.8.
- 9.0 Process Controls. All Process Controls shall be completed in accordance with WP 103 00 in TM 1-1500-366-23 prior to part inspection.
- 10.0 Inspection Procedure. A magnetic field shall be applied to the part perpendicular to the orientation of suspected cracks; refer to Figure 2. This inspection requires two (2) shots for complete inspection coverage; see Figure 3.
- Place the part in the coil.
  - Press the test switch and spray the Magnetic Particle media on the part. Stop spraying the media momentarily before removing pressure from the test switch. Test current should be applied for no longer than five (5) seconds. Wait thirty (30) seconds for indications to build before inspection.
  - Inspect for cracks with the black light.
  - Turn the Strap Fitting over 180° in the coil and repeat steps a. through c. Refer to Figure 3.
  - Demagnetize the part in accordance with TM 1-1500-256-23 paragraph 1.4.9.1 to sufficiently reduce the residual field to 2 units or less on a field indicator, or 3 units or less on a gauss meter in accordance with paragraph 3.4.11.2.3 in TM 1-1500-335-23.

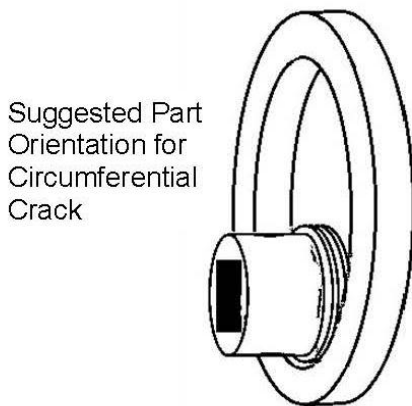
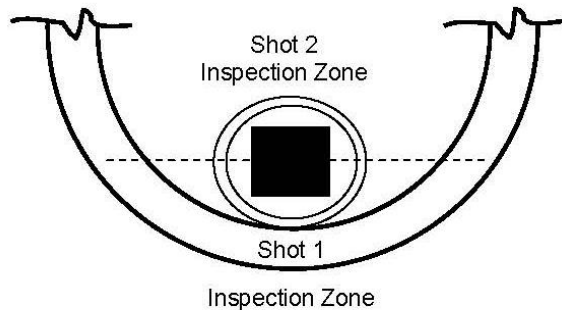

Figure 2



Inspection Zone

Figure 3

# ADDENDUM TO UH-1-11-ASAM-02

## MAIN ROTOR HUB INBOARD STRAP FITTING

- 11.0 Marking and Recording of Inspection Results. Mark and record the inspection results as necessary per paragraph 1.3.
- 12.0 Backup Method. None required.
- 13.0 System Securing. Clean the MR Inboard Strap Fitting to remove inspection media. Refer to Post Cleaning and Restoration of Part or Area after NDI, paragraph 1.4.16. The Strap Fitting requires installation in accordance with the applicable MD Helicopter technical manuals.