

Dear Editor,

We made a fail-safe puller for removing the plastic sight gage glasses on all Bell choppers. The one shown on Page 43 of PS 332 has a tendency to slip, and there is no puller in our tool kits.

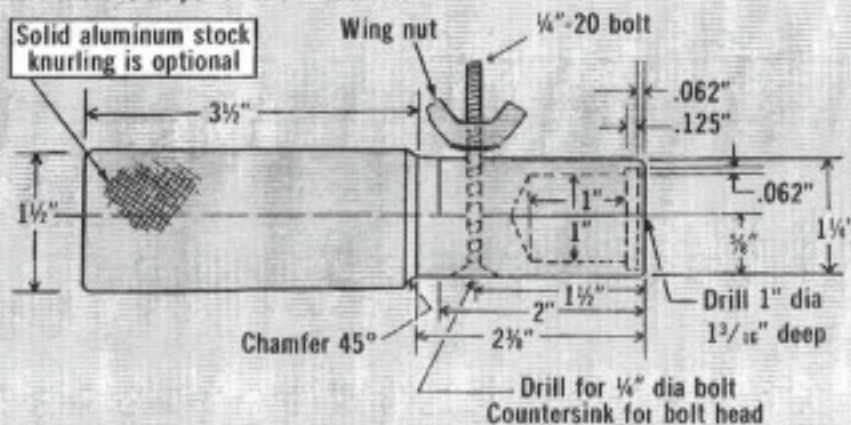

We made our puller from 1 1/2-in aluminum round stock, about 6 inches long. It's real easy to make and will prevent glasses from being damaged from using other removal methods... saves on replacement costs.

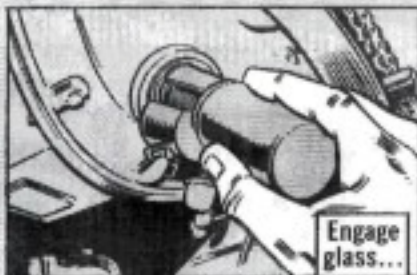

To use the tool, just insert it over the sight glass, tighten the wing nut, and p-u-l-l. That's all there is to it!

SGT Jerold L. Fry  
Ft. Bliss, TX

(Ed Note—Your tool looks like a winner, Sarge!)